

# SIRUBA

使用說明書與零件圖

INSTRUCTIONS BOOK & PARTS LIST

DL8000-RM1



1、主要部件名称 .....	1	1、MAIN PARTS .....	19
2、主要技术参数 .....	1	2、MAIN SPECIFICATIONS .....	19
3、缝纫机的安装 .....	2	3、INSTALLATION .....	20
4、缝纫前的准备 .....	4	4、PREPARTION BEFORE SEWING .....	22
4-1、机针的安装方法 .....	4	4-1、Installing the needle .....	22
4-2、梭芯套的装取方法 .....	4	4-2、Installing the bobbin case .....	22
4-3、面线的穿法 .....	5	4-3、Threading the upper thread .....	23
4-4、针距的调节方法 .....	5	4-4、Adjusting the stitch lenght .....	23
5、缝纫 .....	6	5、SEWING .....	24
5-1、缝纫的方法 .....	6	5-1、Sewing .....	24
5-2、倒缝加固缝的方法 .....	6	5-2、Backtacking .....	24
6、缝纫效果 .....	7	6、THREAD TENSION .....	25
6-1、线张力的调节 .....	7	6-1、Adjusting the thread tension .....	25
6-2、压脚压力的调节 .....	8	7、CLEANING .....	26
6-3、剪线后面线线留长度的调节 .....	8	8、STANDARD ADJUSTMENT .....	27
7、保养(日常清洁程序) .....	9	8-1、thread springs .....	27
8、标准调整 .....	10	8-2、Cabinet line-oriented R .....	28
8-1、挑线弹簧 .....	10	8-3、Presser foot height .....	28
8-2、机壳线导向 R .....	11	8-4、Feed dog height .....	29
8-3、压脚高度 .....	11	8-5、Feed dog tilt .....	29
8-4、送布牙的高度 .....	12	8-6、Needle bar height .....	30
8-5、送布牙的倾斜 .....	12	8-7、Machine needle and feed synchronization .....	30
8-6、针杆的高度 .....	13	8-8、Machine needle and the hook of the synchronization .....	31
8-7、机针和送布的同步 .....	13	8-9、Adjusting the rotary hook lubrication amount .....	31
8-8、机针和旋梭的同步 .....	14	8-10、Adjusting the upper cutter .....	32
8-9、旋梭供油量的调整 .....	14	8-11、Adjusting the upper cutter .....	33
8-10、上切刀的安装 .....	15	8-12、Parts changement .....	34
8-11、上切刀位置的调节 .....	16	9、PARTS CHANGEMENT .....	35
8-12、量规零件的更换 .....	17		
9、定规件一览表 .....	18		

## 1、主要部件名称



- ①切刀
- ②壓腳
- ③針桿
- ④電子夾線器
- ⑤倒縫開關
- ⑥直驅馬達
- ⑦操作面板
- ⑧三眼過線勾

## 2、主要技术参数

型号	HL-7700ZQ	HL-7700Z	HL-7700E-303/QX	HL-7700E-803/QX
名称	直驱式侧切刀 带包边平缝机	直驱式一体式 侧切刀平缝机	三自动一体式 侧切刀平缝机	四自动一体式 侧切刀平缝机
最大转速	4500rpm			
最大针距	5mm			
压脚高度	手动	6mm		
	膝控	13mm ( 电磁抬压脚 : 10mm )		
机针	DXB1(9#-18#)			
针位	6.4mm	3.2mm,4.0mm,4.8mm,6.4mm,9.5mm		

### 3、缝纫机的安装

#### ⚠ 注意

- ⊘ 请让受过培训的技术人员来安装缝纫机。
- ⊘ 在安装完成前，请不要连接电源，如果误踩下了起动踏板，缝纫机动作会导致受伤。
- ⚠ 请委托购买商店或电气专业人员进行电气配线。
- ⚠ 必须保证接地。
- ⚠ 缝纫机重约33公斤，安装工作必须由两人以上来完成。
- ⚠ 如果接驳地线不牢固，是造成触电或误动作的原因。
- ⚠ 请在缝纫机头部安装皮带罩壳。
- ⚠ 缝纫机倒下时，请一定要固定工作台，不可使其随意移动。
- ⚠ 工作台移动易发生脚被夹住等事故，是导致人身事故的原因。

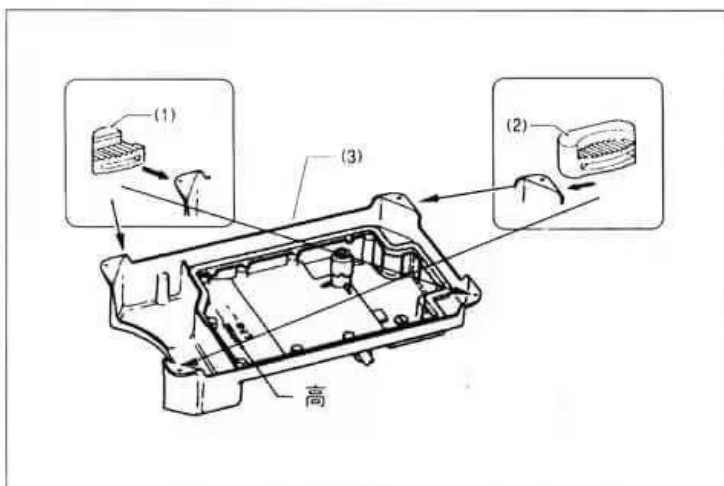

#### 1、油盘

- 1) 头部防震垫(左) [2个]
- 2) 头部防震垫(右) [2个]
- 3) 油盘
- 4) 磁铁

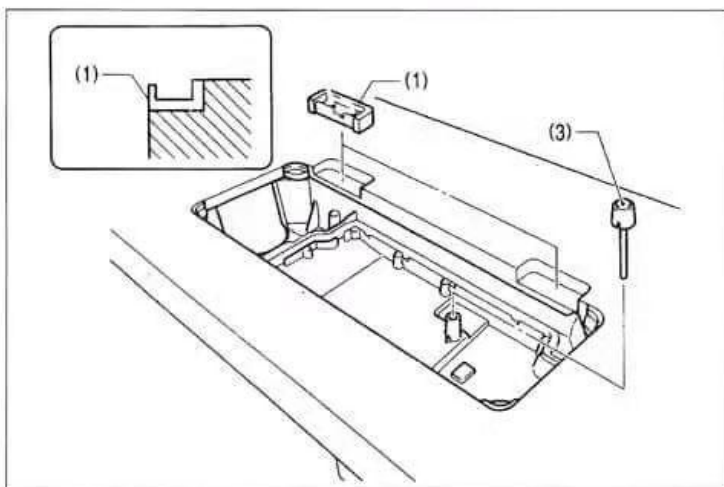

#### 2、机壳铰链

- 1) 机头铰链套[2个]
- 2) 钉[4个]

#### 3、膝控提升顶杆

- 3) 膝控提升顶杆

1、主要部件名称 .....	1	1、MAIN PARTS .....	19
2、主要技术参数 .....	1	2、MAIN SPECIFICATIONS .....	19
3、缝纫机的安装 .....	2	3、INSTALLATION .....	20
4、缝纫前的准备 .....	4	4、PREPARTION BEFORE SEWING .....	22
4-1、机针的安装方法 .....	4	4-1、Installing the needle .....	22
4-2、梭芯套的装取方法 .....	4	4-2、Installing the bobbin case .....	22
4-3、面线的穿法 .....	5	4-3、Threading the upper thread .....	23
4-4、针距的调节方法 .....	5	4-4、Adjusting the stitch lenght .....	23
5、缝纫 .....	6	5、SEWING .....	24
5-1、缝纫的方法 .....	6	5-1、Sewing .....	24
5-2、倒缝加固缝的方法 .....	6	5-2、Backtacking .....	24
6、缝纫效果 .....	7	6、THREAD TENSION .....	25
6-1、线张力的调节 .....	7	6-1、Adjusting the thread tension .....	25
6-2、压脚压力的调节 .....	8	7、CLEANING .....	26
6-3、剪线后面线线留长度的调节 .....	8	8、STANDARD ADJUSTMENT .....	27
7、保养(日常清洁程序) .....	9	8-1、thread springs .....	27
8、标准调整 .....	10	8-2、Cabinet line-oriented R .....	28
8-1、挑线弹簧 .....	10	8-3、Presser foot height .....	28
8-2、机壳线导向 R .....	11	8-4、Feed dog height .....	29
8-3、压脚高度 .....	11	8-5、Feed dog tilt .....	29
8-4、送布牙的高度 .....	12	8-6、Needle bar height .....	30
8-5、送布牙的倾斜 .....	12	8-7、Machine needle and feed synchronization .....	30
8-6、针杆的高度 .....	13	8-8、Machine needle and the hook of the synchronization .....	31
8-7、机针和送布的同步 .....	13	8-9、Adjusting the rotary hook lubrication amount .....	31
8-8、机针和旋梭的同步 .....	14	8-10、Adjusting the upper cutter .....	32
8-9、旋梭供油量的调整 .....	14	8-11、Adjusting the upper cutter .....	33
8-10、上切刀的安装 .....	15	8-12、Parts changement .....	34
8-11、上切刀位置的调节 .....	16	9、PARTS CHANGEMENT .....	35
8-12、量规零件的更换 .....	17		
9、定规件一览表 .....	18		

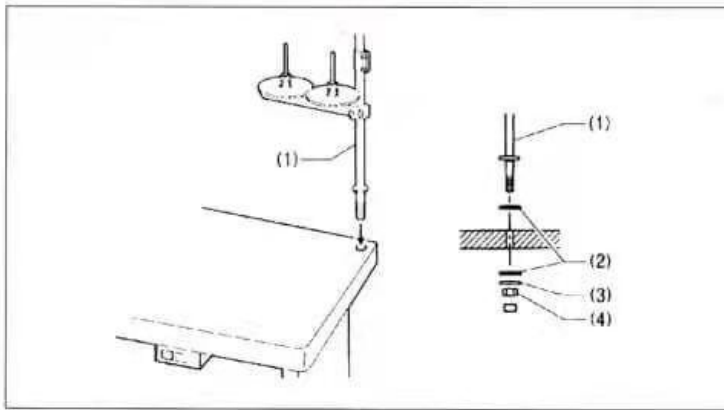

## 6、线架

### 1) 线架

#### 注意：

夹入橡皮垫片(2) [2片]和垫圈(3),然后拧紧螺母(4),使线架(1)不能移动。

## 4、缝纫前的准备

### ⚠ 注意



安装机针时，请切断电源。  
当误按起动开关时，缝纫机会导致人员受伤。

### 4-1、机针的安装方法

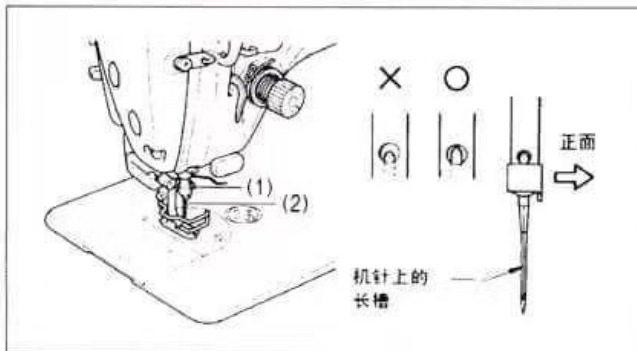

- 1、转动缝纫机手轮，将针杆移至最高位置。
- 2、松开螺钉(1)。
- 3、将机针(2)笔直插入到位，确认机针上的长槽面处于左侧，然后拧紧螺钉(1)。

### 4-2、梭芯套的装取方法

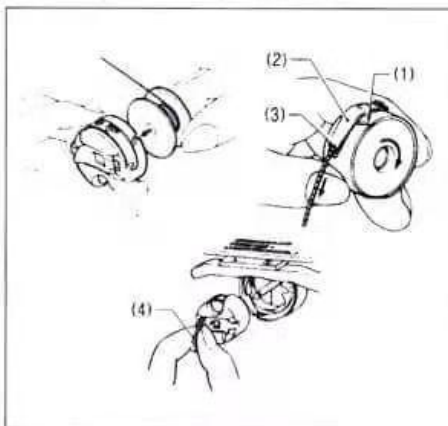

- 1、转动手轮将机针起，直至到针板上方。
- 2、握住梭芯以便向右卷绕底线，将梭芯插入梭芯套。
- 3、将底线穿过线槽(1)和夹线弹簧(2)的下方，然后从线导线器(3)中拉出。
- 4、当拉出底线后，检查梭芯是否向右方向回转。
- 5、当拉出(4)装在梭芯套上，再将梭芯套插入旋梭。

### 4-3、面线的穿法

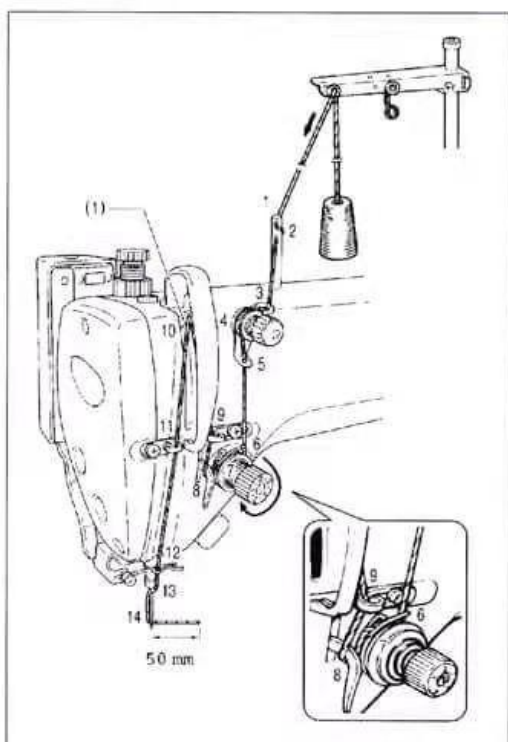

在穿引面线之前转动手轮。抬高挑线杆(1)。这样会使穿引更加容易，并防止面线在缝纫开始时脱落。

### 4-4、针距的调节方法

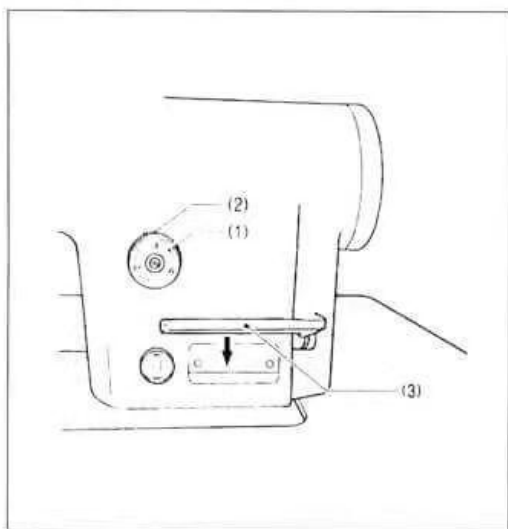

- 1、向上推动旋钮销杆(2)直至听到释放锁的“咔嗒”声。
  - 2、顺时针或逆时针转动针距旋钮(1)，使所需针距处于旋钮的最上端的位置。
- 数字越大，针距越长。(旋钮上的数字用于参考。实际的针距视缝纫面料的种类和厚度而定。在观察缝纫好的针距的同时进行调节。)按设定值从大到小的方向转动针距旋钮(2)时，如果将倒缝扳手(3)推至中央位置，会使旋钮转动更加容易。

## 5、缝纫

### ⚠ 注意



为了安全起见，在使用本缝纫机之前，请安装保护装置。如果未安装这些安全装置就使用缝纫机，会造成人身伤害及缝纫机损坏。



发生下列情况时，请切断电源。  
当误踩踏板时，缝纫机误动作会导致人员受伤。

- 机针穿线时。
- 更换机针或梭芯时。
- 缝纫机不使用，或人离开缝纫机时。



缝纫过程中不要触摸任何活动部件或将运动部件靠在运动部件上，因为这会导致受伤或缝纫机损坏。

### 5-1、缝纫的方法

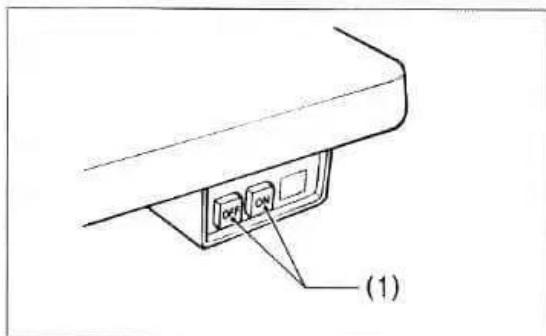

- 1、按下 ON (打开) 电源开关 (1)。
- 2、踩下脚踏板开始缝纫。

### 5-2、倒缝加固缝的方法

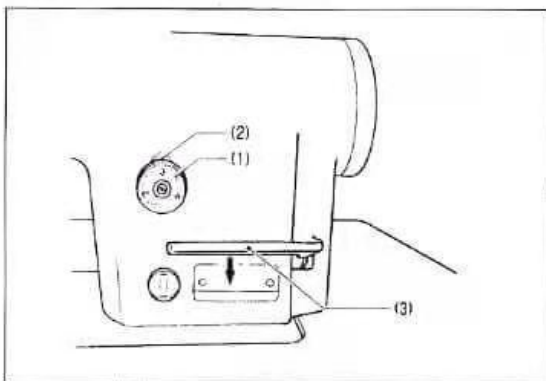

在缝纫过程中，按下倒缝扳手(3)时，送料方向将会相反。释放时，送料方向恢复正常。

## 6、缝纫效果

### ⚠ 注意



取出梭芯套时，请切断电源。  
当误按动启动开关时，缝纫机动作会导致人员受伤。

### 6-1、线张力的调节

正确线迹

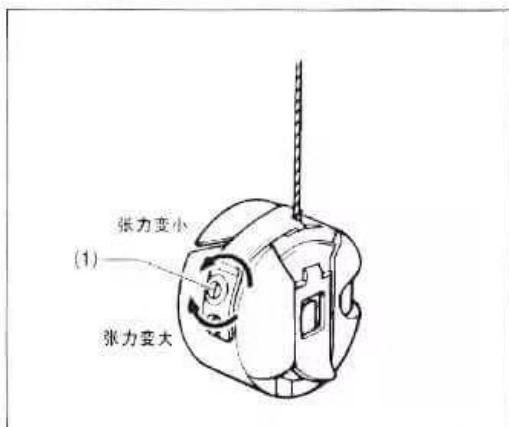
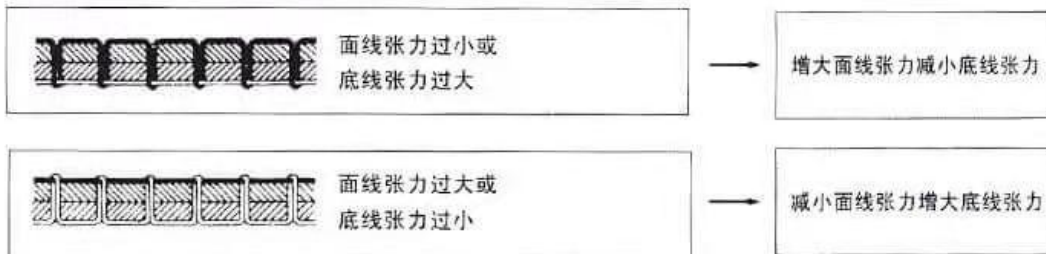

#### <底线张力>

拉住从梭芯套中露出的线头，转动调节螺钉(1)进行调节直至梭芯套以自重慢慢下垂落。

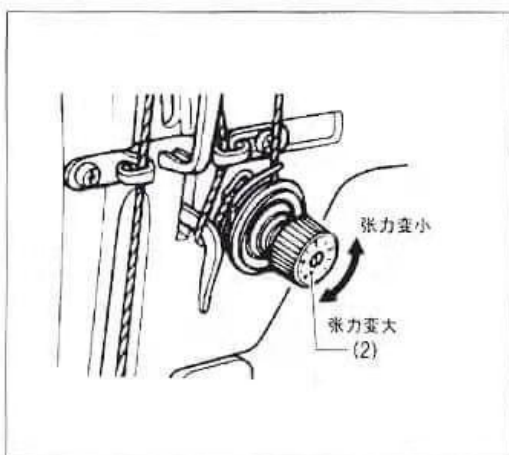

#### <面线张力>

在底线张力调节之后，调节面线张力以使针脚均匀平整。

- 1、放下压脚。
- 2、转动夹线螺母(2)进行调节。

## 6-2、压脚压力的调节

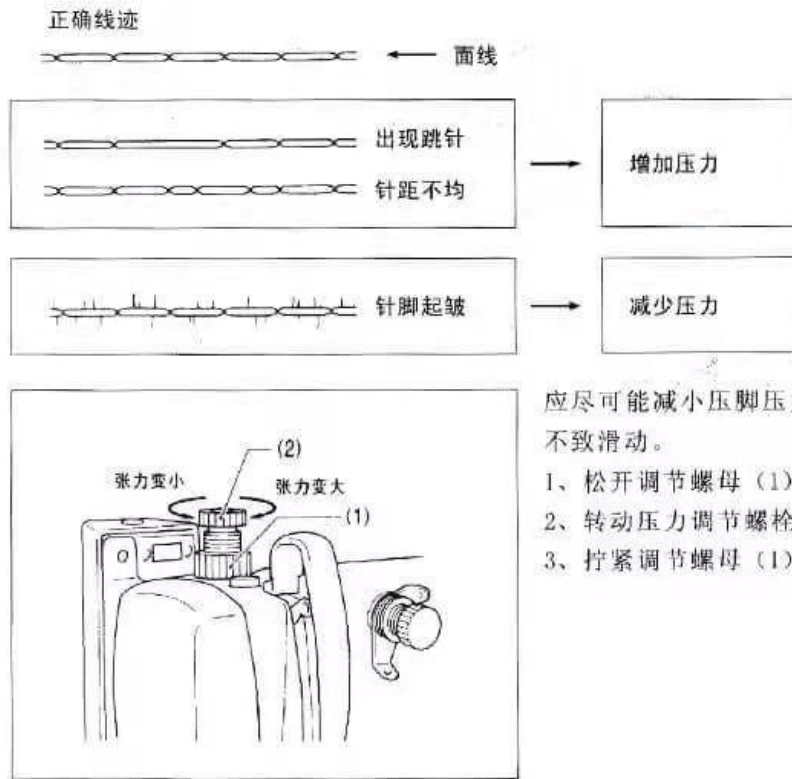

应尽可能减小压脚压力，但须有足够压力使面料不致滑动。

- 1、松开调节螺母（1）。
- 2、转动压力调节螺栓（2）以调节压脚压力。
- 3、拧紧调节螺母（1）。

## 6-3、剪线后面线线留长度的调节

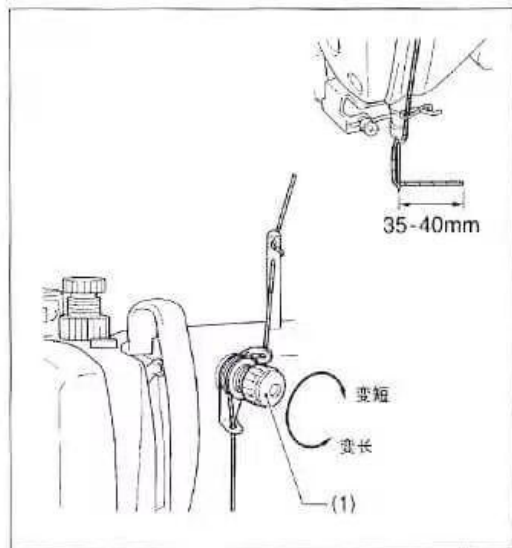

- 前线时，线张力松弛，仅用夹线器(1)施加张力。
  - 面线的标准残留长度为35-40mm。
  - 如果增加夹线器(1)的张力，切线后面线残留长度将会调少；减少张力，长度将会增加。
- 回转夹线器(1)进行调节。

## 7、保养(日常清洁程序)

### ⚠ 注意



在开始清洁作业前，请切断电源。  
如果误踩了踏板，缝纫机会导致人员受伤。



使用润滑油和黄油时，务必戴好保护眼镜和保护手套，以防润滑油落入眼中或沾到皮肤上，这是引起发炎的原因。

另外润滑油或黄油不能饮用，否则会引起呕吐和腹泻。将油放在小孩拿不到的地方。

为了保持缝纫机的机能，而且能长久的使用，请每天保养。另外，缝纫机如果长时间未使用，请在进行如下的保养后再使用。

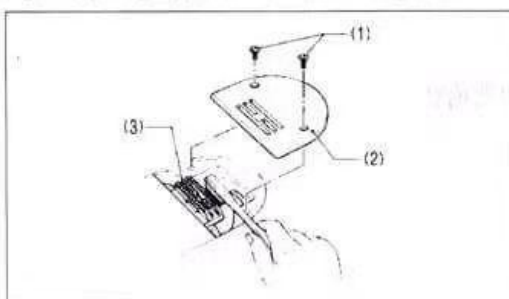

- 1、抬起压脚。
- 2、将两只螺钉(1)拆下，然后拆下针板(2)。
- 3、用软毛刷清除送布牙(3)上的灰尘。
- 4、用两只螺钉(1)将针板(2)装上。

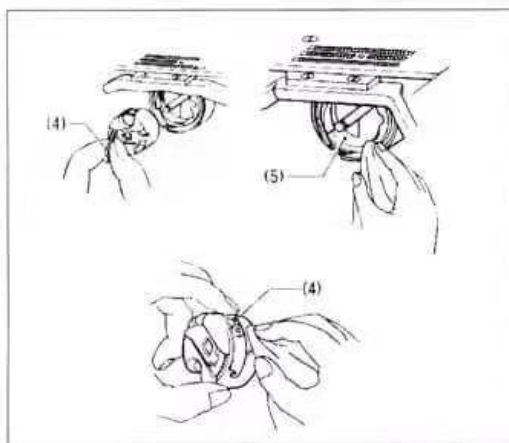



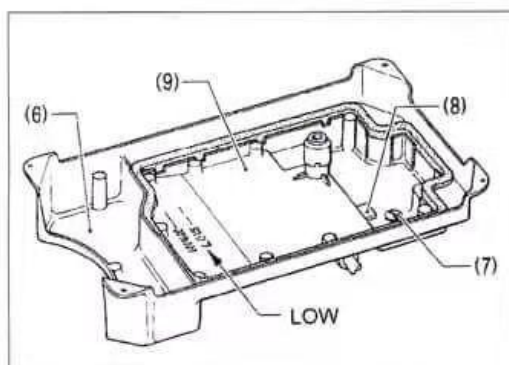



- 5、向后倾斜缝纫机头部。
- 6、拆下梭芯套(4)。
- 7、用软布擦去旋梭(5)上的灰尘，检查旋梭(5)是否受损。
- 8、将梭芯从梭芯套(4)上拆下，用布清洁梭芯套(4)上的灰尘。
- 9、将梭芯装入梭芯套(4)。再将梭芯套(4)重新装入缝纫机。



- 10、用布擦试油盘底部(6)聚积的油污。
- 11、如果油而低于 <LOW> 的基线时，请务必补充润滑油。
  - \* 请使用通宇公司指定的缝纫机润滑油。
  - \* 如果润滑油已污染了的话，请取下放油螺钉(7)，更换润滑油。
  - \* 使用布擦去聚集在磁铁(8)周围的污物及清除干净沾在油盘(9)上的油污。

## 8、标准调整

### ⚠ 注意

-  只有经过训练的技术人员才能进行缝纫机的维修、保养和检查。
-  与电气有关的维修、保养和检查请委托购买商店或电气专业人员进行。
-  取下的安全保护装置，再次安装时，请务必安装在原位上，并检查能否正常的发挥作用。
-  缝纫机头倒下时，请一定要固定工作台，不可使其随意移动。  
工作台移动易发生脚等被夹住之事故，是导致人身事故的原因。
-  发生下列情况时，请关闭电源。并拔下电源插座。只是在切断电源后，马达在稍后的一段时间内因惯性仍会继续转动，请在马达完全停止后，再进行作业。  
当误踩下脚踏板时，缝纫机动作会导致受伤。
  - 检查，调整和维修
  - 更换旋梭等易损零部件
-  在必须接上电源开关进行调整时，务必十分小心遵守所有的安全注意事项。

### 8-1、挑线弹簧

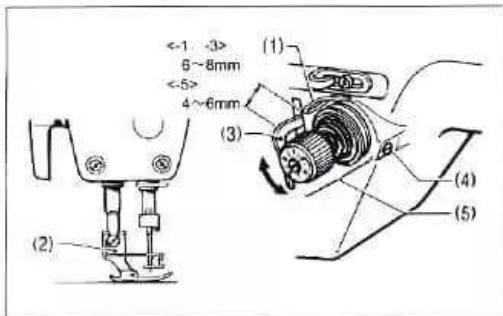

#### <挑线弹簧的位置>

标准的挑线弹簧(1)的位置是在压脚(2)放下的状态下，以位于线导向(3)的上方6-8mm[-5规格时为4-6mm]处。

- 1、放下压脚(2)。
- 2、松开螺钉(4)。
- 3、调节夹线器杆架(5)的旋转位置。
- 4、拧紧螺钉(4)。

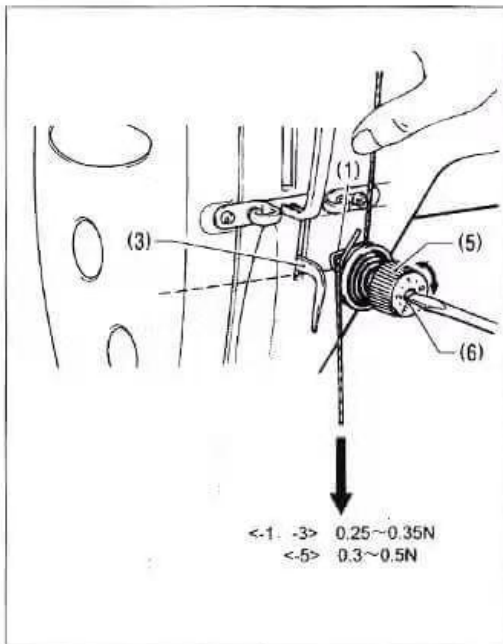

#### <挑线弹簧的强度>

根据不同的规格，其挑线弹簧(1)的标准强度为下列所示。

-1、-3规格	0.25-0.35N
-5规格	0.3-0.5N

- 1、在夹线器杆架(5)的稍微上方处，用手指压住面线使其不要被拉出来。
- 2、向下拉面线，直到挑线弹簧(1)与线导向(3)的底面高度一致时，然后测量挑线弹簧(1)的强度。
- 3、将起子插入夹线螺杆(6)的槽中，旋转起子，可调整挑线弹簧(1)的强度。

<-1、-3> 0.25~0.35N  
<-5> 0.3~0.5N

## 8-2、机壳线导向 R

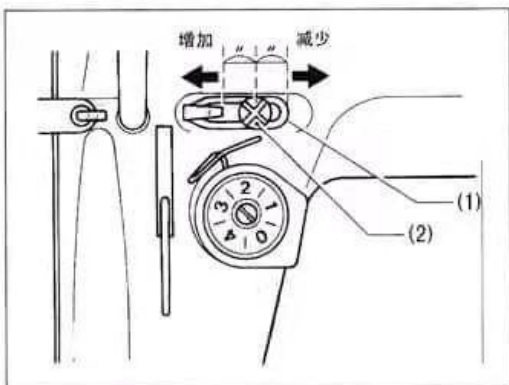

机壳线导向R(1)的标准安装位置是在螺钉(1)位于机壳线导向R(1)的可调范围中心处。

\* 旋松螺钉(2)，移动机壳线导向R(1)进行位置的调节。

• 当缝纫厚料时，向左移动机壳线导向R(1)，(挑线量增加。)

• 当缝纫薄料时，向右移动机壳线导向R(1)。(挑线量减少。)

## 8-3、压脚高度

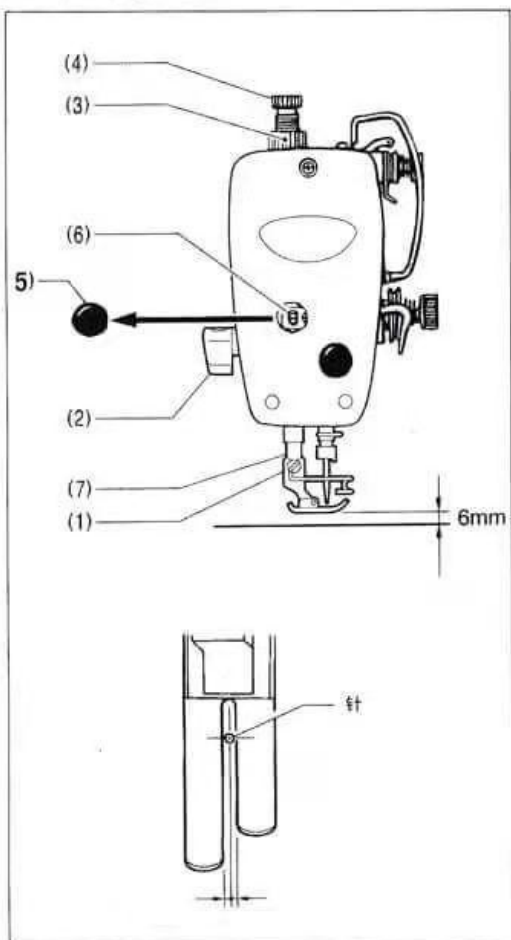

使用抬压脚扳手(2)抬高压脚(1)时，压脚的标准高度是 6mm。

1、旋松螺母(3)和压脚调节螺栓(4)，对压脚不施加压力。

2、使用抬压脚扳手(2)来抬高压脚(1)。

3、取下面板倒均橡皮塞(5)。

4、旋松螺栓(6)，上下移动压杆(7)，调整压脚(1)的高度为 6mm。

5、拧紧螺栓(6)。

6、安装上橡皮塞(5)。

7、通过压脚调节螺栓(4)来调整压脚压力，拧紧螺母(3)。

\* 调整完后回转缝纫机手轮，确认机针应下降在压脚槽的正中处。

## 8-4、送布牙的高度

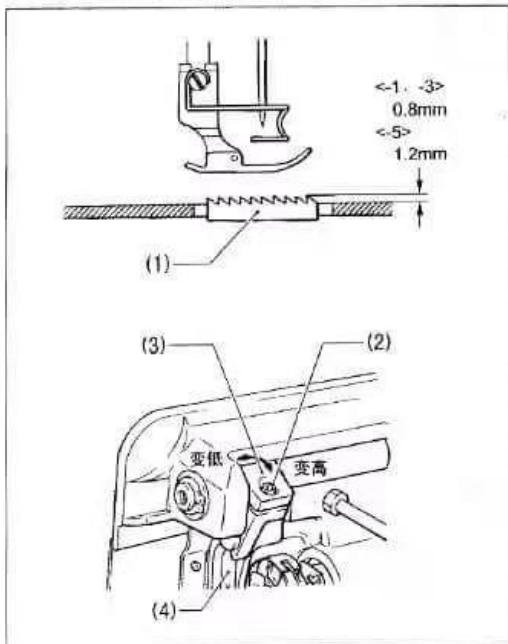

将送布牙(1)移到针板上方最高处时,此时的标准高度对-1和-3规格应为0.8mm、对-5规格应为1.2mm。

- 1、回转缝纫机手轮,将送布牙(1)移到针板上方最高处。
- 2、放倒缝纫机机头。
- 3、旋松螺钉(2)。
- 4、旋转上下抬牙叉(3)使牙架(4)上下移动来进行调整。
- 5、拧紧螺钉(2)。

## 8-5、送布牙的倾斜

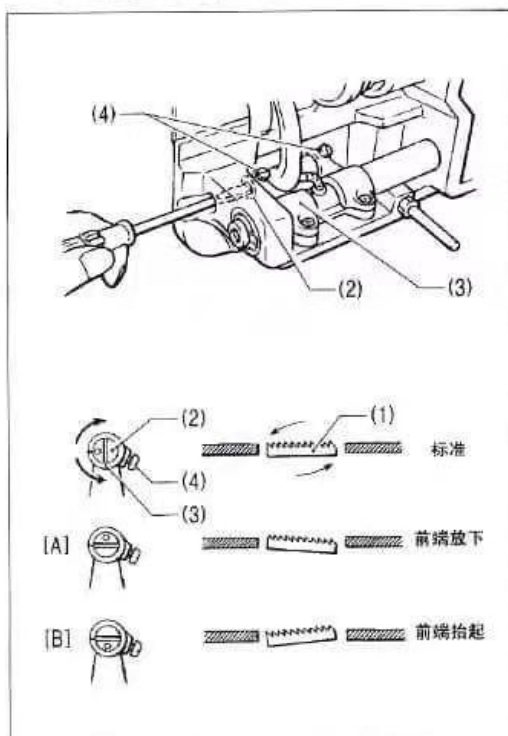

送布牙(1)位于针板最高处时的标准倾斜是牙架曲柄偏心轴(2)上的钢印(0)与牙架曲柄(3)上的标记,一致送布牙(1)与针板平行。

- 1、转动缝纫机手轮,将送布牙(1)移到针板上方最高处的位置。
  - 2、放倒缝纫机机头。
  - 3、将螺钉(4)[2个]松开。
  - 4、根据标准位置,在 $90^\circ$ 的范围内按剪头方向调整牙架曲柄偏心轴(1)。
    - 为了防止起皱,可降低送布牙(1)的前端。(图A)
    - 为了防止在重叠缝纫时布料不一致[缝线不合],可抬高送布牙(1)的前端。(图B)
  - 5、将螺钉(4)[2个]完全拧紧。
- \* 调整送布牙(1)的倾斜度后,送布牙(1)的高度也会改变,因此请再一次调整送布牙(1)的高度。

## 8-6、针杆的高度

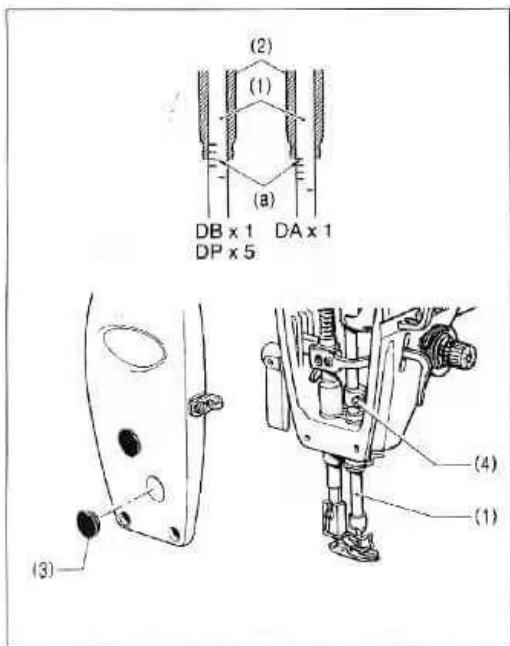

针杆(1)到达最下位置时,针杆(1)的基线(a),如图所示要与针杆轴套(2)的下端保持对齐。

- 1、转动缝纫机手轮,使针杆(1)到达最下位置。
- 2、取下面板上的橡皮塞(3)。
- 3、旋松螺钉(4),将针杆(1)进行上下移动来进行调整。
- 4、拧紧螺钉(4)。
- 5、安装上橡皮塞(3)。

## 8-7、机针和送布的同步

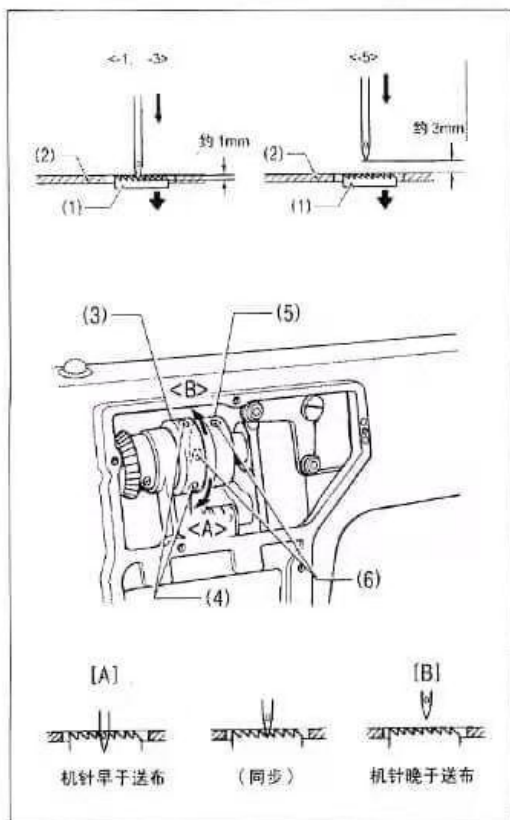

送布牙(1)从最高位置开始下降到和针板(2)的表一致时,机针的尖端应在如左图所示的位置上时为标准位置。

- 1、拆下侧板。
- 2、松开上下偏心轮(3)上的螺钉(4) [2个]和水平偏心轮(5)上的螺钉(6) [2个],稍稍回转上下偏心轮(3)和水平偏心轮(5)来进行调整。

(因为上下偏心轮(3)和水平偏心轮(5)是使用销来连接的,所以只要回转一方即可。)

- 如要使机针早于送布时,可向<A>的方向回转,要使机针晚于送布时,可向<B>的方向回转。
- 为了防止在重叠缝纫时布料不一致[缝线不合],可将机针的时序调晚些。(图[B])
- 为了使收线良好,可将机针的时序调早些。(图[A])

注意:

如过度的将上下偏心轮(3)和水平偏心轮(5)向<A>的方向回转时,易成为机针折断的原因。

- 3、调整完了后,拧紧螺钉(4)和螺钉(6)。

## 8-8、机针和旋梭的同步

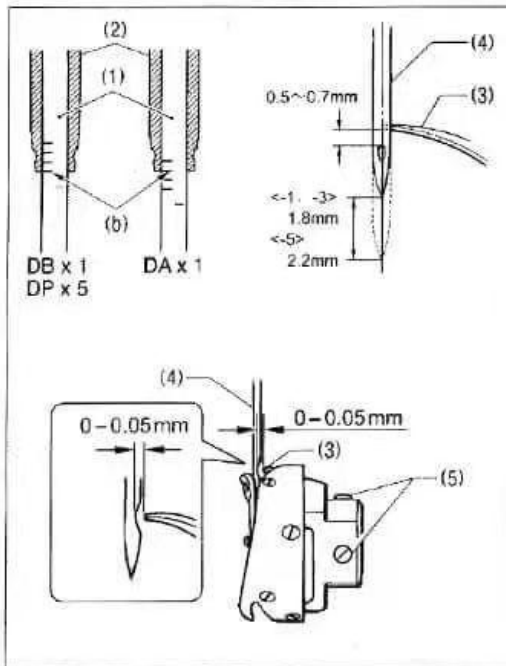

当针杆(1)从最低位置升到1.8mm(-5规格时为1.2mm)时,如图所示,基线(b)与针杆轴套(2)的下端保持对齐时,旋梭尖(3)与机针(4)的中心必须一致。

(此时,针眼上缘与旋梭尖之间的间隙为0.5-0.7mm。)

1、转动缝纫机手轮,使针杆(1)从最低位置上升到如图所示的基线(b)与针杆轴套(2)的下端保持对齐为止。

2、旋松固定螺钉(5)[3个],使旋梭尖(3)与机针(4)的中心一致。

此时,旋梭尖(3)与机针(4)之间的间隙为0-0.05mm。

3、拧紧固定螺钉(5)[3个]。

## 8-9、旋梭供油量的调整

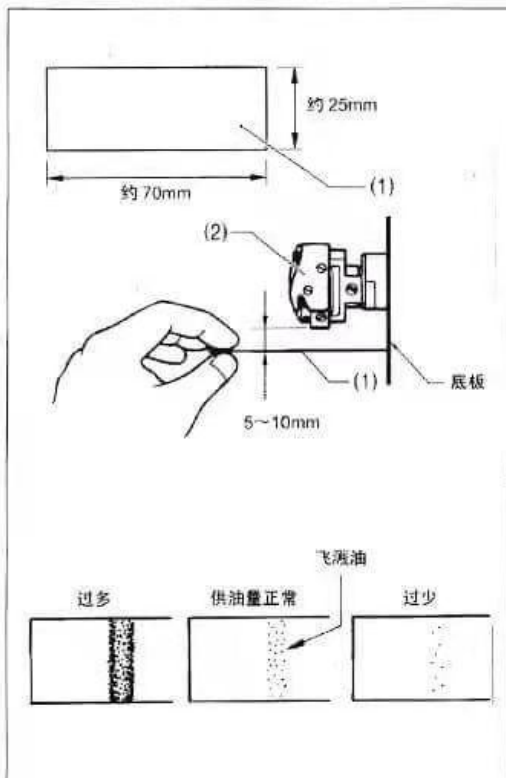

如更换了旋梭或要变更缝纫速度时,请按下述步骤调整旋梭的供油量。

<供油量的确认>

- 1、拆去挑线杆至机针上的线。
- 2、用抬压脚扳手抬起压脚。
- 3、以缝纫机实际缝纫时的转速进行约1分钟的空运转(适度的断续运转)。
- 4、将油量测试纸(1)插入旋梭(2)的下面并握住,以缝纫机实际进行缝纫时的转速使缝纫机运转8秒钟。(对油量测试纸(1)的纸质没有什么要求。)
- 5、确认飞溅到测试纸上的油量。

当需要进行调整时,请按下面(供油量的调整)一节所述进行调整作业。

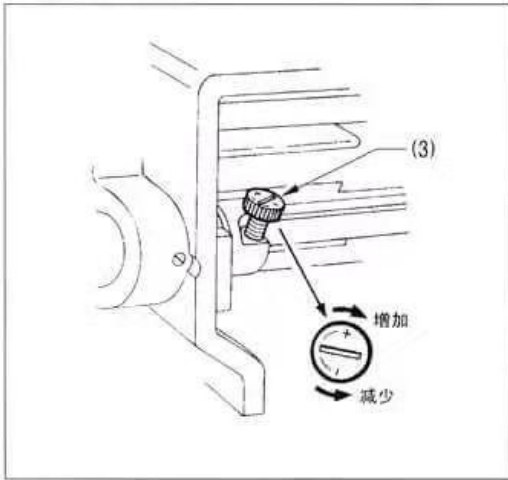

#### <供油量的调整>

- 1、将缝纫机头部倒下。
- 2、转动油量调整螺钉(3)，调整供油量。
  - 向右转动油量调整螺钉(3)供油量增加。
  - 向左转动油量调整螺钉(3)供油量减少。
- 3、参阅上述[供油量的确认]所述来检查供油量。
  - \* 请反复转动油量调整螺钉(3)，进行调整及供油量的确认，直到获得适当的供油量为止。
- 4、在进行了约 2 小时的缝纫后，请再次检查供油量。

### 8-10、上切刀的安装

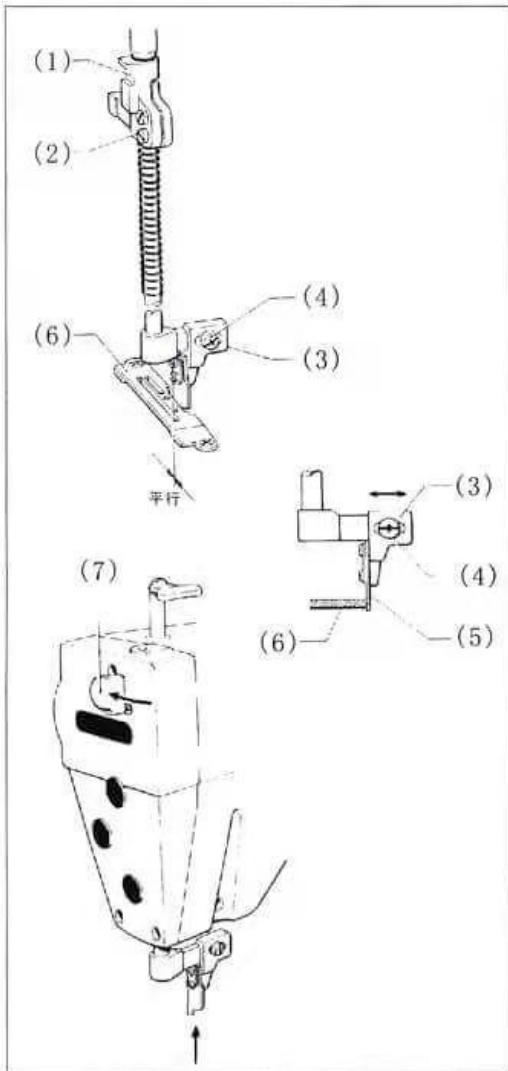

- 1、将切刀轴导向架(1)的固定螺丝(2)，切刀架(3)的固定螺丝松开(4)。
  - 2、将上切刀(5)的侧面调整到与针板(6)的下切刀部轻轻接触的状态，将切刀架(3)的固定螺丝(4)，轻轻锁住。
  - 3、将上切刀(5)的侧面调整到与针板下切刀部平行，切刀导向架(1)的固定螺丝(2)锁紧。
  - 4、将切刀架(3)的固定螺丝(4)松开，将上切刀(5)调整到与针板(6)的切刀部轻轻接触状态，后锁紧螺丝(4)。
- ※上切刀(5)与针板(6)的切刀部位过强接触会导致上切刀(5)的解除扳手(7)按下而不返回情况出现。调整后，一定要确认按下扳手(7)时，上切刀能顺利上升。

## 8-11、上切刀位置的调节

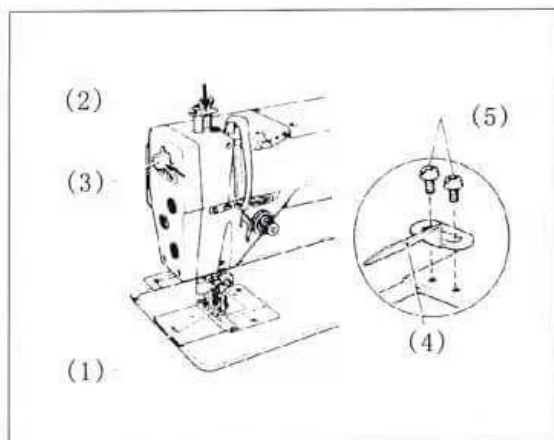

上切刀起动时，向下按入切刀扳手(2)，上切刀会与缝纫机同时动作上切，上切刀停止时，按下解除扳手，上切刀(1)提起停止。

※ 上切刀的起动、停止必须在缝纫机停止时操作。

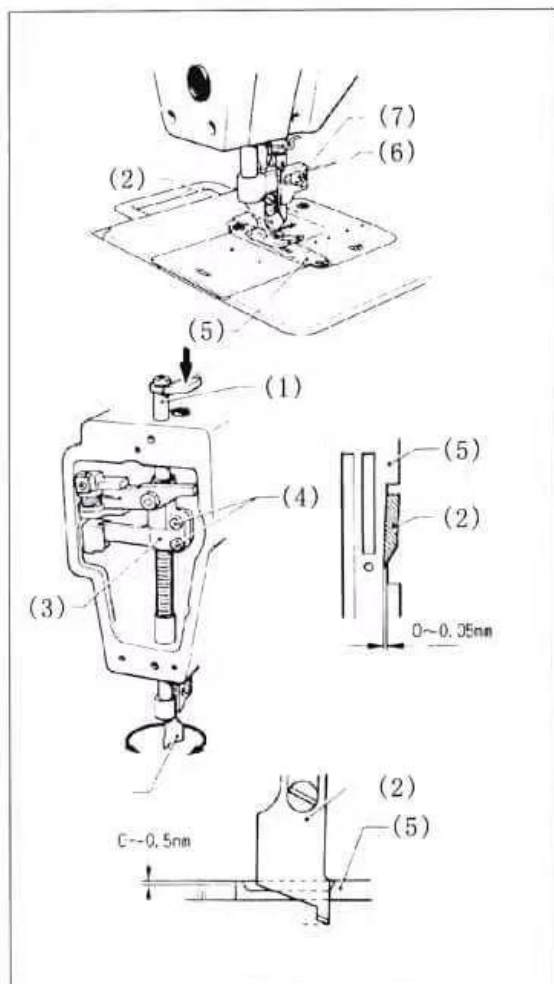

1、将上切刀扳手(1)按下，转动主动轮，使上切刀达到最下点。

2、切刀轴导向架(3)的固定螺丝(4)2颗松开，使切刀(2)的侧面轻轻碰到针板，锁紧2颗切刀导向固定螺丝(4)。

3、上切刀(2)与针板(5)的位置关系，调整如图位置

※ 上切刀(2)与针板(5)的切刀部位过强接触会导致上切刀(2)的解除搬手(1)按下而不返回情况出现。调整后，一定要确认按下扳手(1)时，上切刀能顺利上升。

## 8-12、量规零件的更换

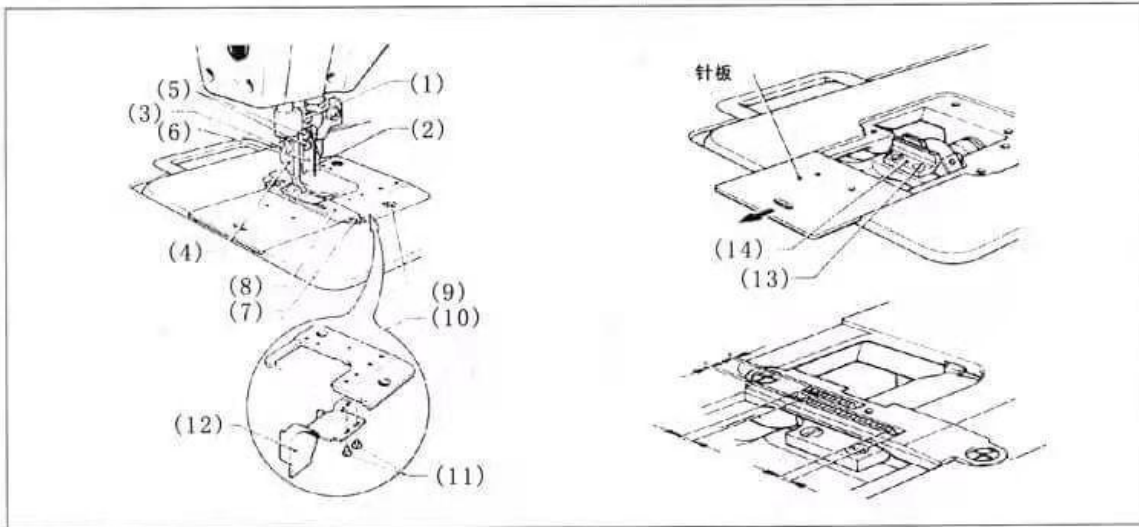

### 切断面的调整

切断面的种类请参照量规零件一览表进行更换。

- 1、放松螺丝(1)将针(2)拆下，拆下螺丝(3)将压脚取下，放松2颗螺丝(5)，将上切刀(6)从下面拆下来。
- 2、拆下2颗螺丝(7)，将针板(8)取下，拆下2颗螺丝(9)，取下盖板(10)，拆下2颗螺丝(11)，从盖板(10)上拆下切屑罩(12)。
- 3、拆下2颗螺丝(13)，取下送布牙(14)。

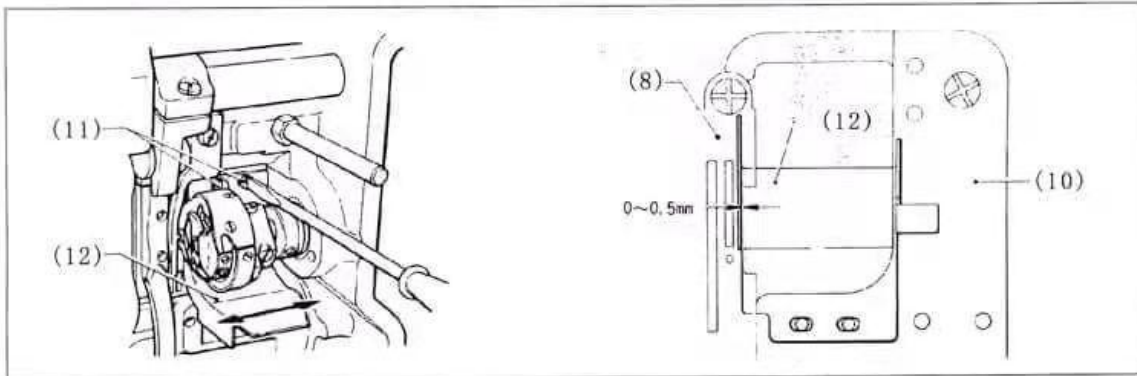

- 4、用2颗螺丝(11)将切屑罩(12)暂时固定在盖板(10)的背面，暂时用2颗螺丝(13)将送布牙锁，用2颗螺丝(9)将盖板锁紧，用2颗螺丝(7)将针板锁紧。







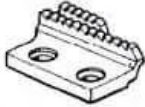
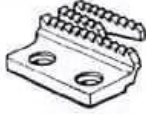

※请转动缝纫机滑动，送布牙(14)在针板(8)的槽内。能分出前后左右，用螺丝(13)将其锁紧。

※将缝纫机从后边倒过来使切屑罩(12)能左右移动，并插入到针板(8)一侧0~0.5mm的位置，并将刚才暂时锁紧的2根螺丝(11)锁紧。

- 5、用螺丝(5)将送布牙锁紧，螺丝(3)将压脚锁，送布齿的螺丝要牢牢的锁紧。

※锁紧后请参照“9-4”的上齿调整方法、再进行调整。

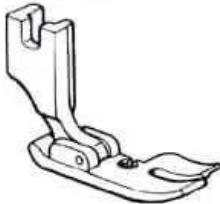
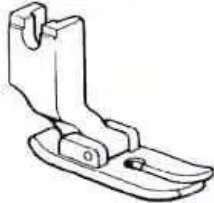
## 9、定规件一览表

送布牙	 <p>S 10583-001</p>				 <p>S 10584-001</p>	
针板	<p>3/32</p>  <p>S 10569-001</p> <p>2.5mm</p>	<p>1/8</p>  <p>S 10570-001</p> <p>3.2mm</p>	<p>5/32</p>  <p>S 10571-001</p> <p>4mm</p>	<p>3/16</p>  <p>S 10572-001</p> <p>4.8mm</p>	<p>1/4</p>  <p>S 10573-001</p> <p>6.4mm</p>	<p>3/8</p>  <p>S 10574-001</p> <p>7.5mm</p>
压脚组件	 <p>S 10576-001</p>				 <p>113280-001</p>	
切刀导向座	 <p>S 10609-001</p>				 <p>S 10614-001</p>	

## 1、MAIN PARTS



- ❶ Cutter
- ❷ The presser foot
- ❸ The needle bar
- ❹ Electronic wire clamping device
- ❺ Reverse stitching switch
- ❻ Direct drive motor
- ❼ Operation panel
- ❽ Three eye linehook

## 2、MAIN SPECIFICATIONS

MODLE	HL-7700ZQ	HL-7700Z	HL-7700E-303/QX	HL-7700E-803/QX
Name	Direct drive side cutter with overlock sewing machine	Direct drive one-piece side cutter flat sewing machine	Three automatic one-piece side cutter flat sewing machine	Four one-piece side cutter automatically flush joint machine
Sewing	4500rpm			
Needle gauge(max)	5mm			
Presser lift height	6mm			
By hand				
By knee	13mm ( Electromagnetic presser foot : 10mm )			
Needle	DXB1(9#-18#)			
Needle position	6.4mm	3.2mm,4.0mm,4.8mm,6.4mm,9.5mm		

### 3、INSTALLATION

#### ⚠ CAUTION

- ⊘ Machine installation should only be carried out by a qualified technician.
- ⊘ Do not connect the power cord until installation is complete. The machine may operate if the treadle is depressed by mistake. Which could result in injury.
- ❗ Contact your Tongyu dealer or a qualified electrician for any electrical work that may need to be done.
- ⚠ Use both hands to hold the machine head when tilting it back or returning it to its original position. If only one hand is used the weight of the machine head may cause your hand to slip, and your hand may get caught.
- ❗ The sewing machine weighs more than 44kg. The installation should be carried out two or more people.

#### 3-1、Installation

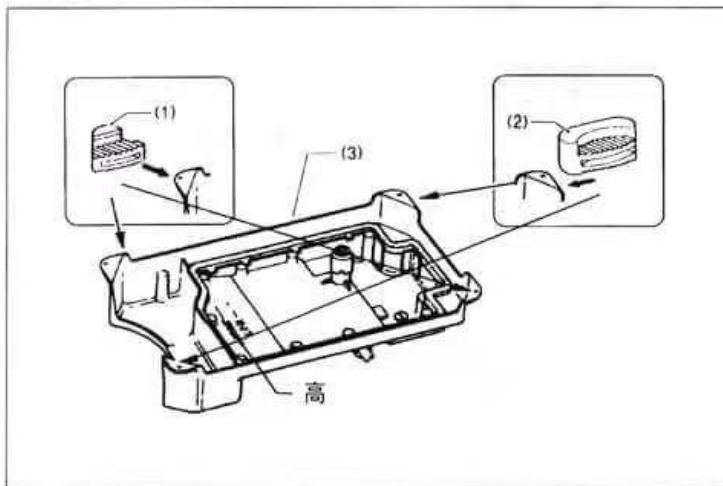

##### 1. Oil pan

- 1) Head cushions(left)[2 purchase].
- 2) Head cushions(light)[2 purchase].
- 3) Oil pan.

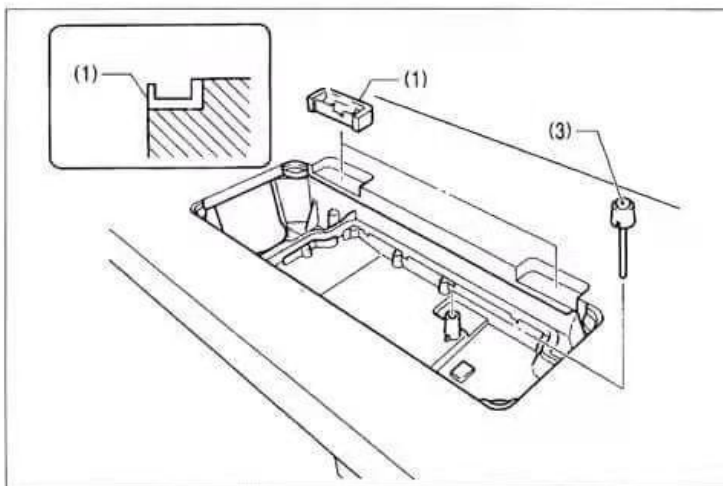

##### 2. Rubber cushions

- 1) Rubber cushions[2 purchase].
- 2) Nails[4 pcs].

##### 3. Knee lifter complying bar

- 3) Knee lifter complying bar.

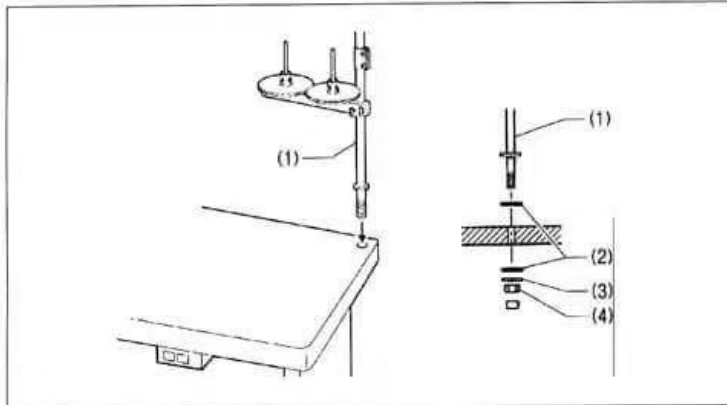

## 6. Cotton stand

1) Cotton stand

### NOTE:

Securely tighten the nut (4) so that the two rubber cushions (2) and the washer (3) are securely clamped and so that the cotton (1) does not move.

## 4. PREPARATION BEFORE SEWING

### ⚠ 注意



Turn off the power switch before installing the needle.  
The machine may operate if the treadle is depressed by mistake, which could result in injury.

### 4-1. Installing the needle

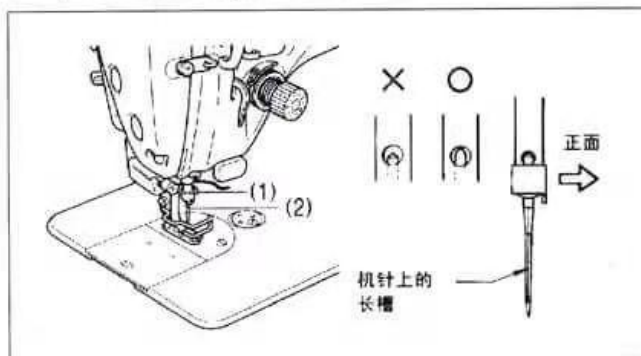

- 1、 Turn the machine pulley to move the needle bar to its highest position.
- 2、 Loosen the screw (1).
- 3、 Insert the needle (2) in a straight line as far as it will go, making sure that the long groove on the needle is at the left, and then securely tighten the screw (1).

### 4-2. Installing the bobbin case

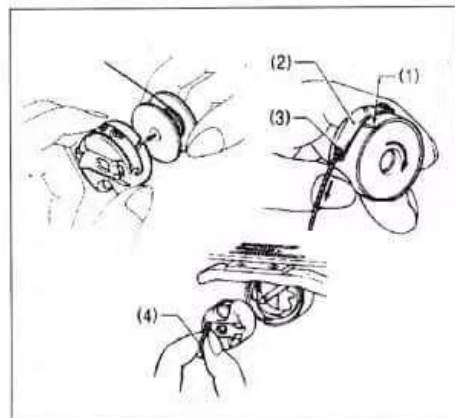

- 1、 Turn the machine pulley to raise the needle until it is above the needle plate.
- 2、 While holding the bobbin so that the thread winds to the right, insert the bobbin into the bobbin case.
- 3、 Pass the thread through the slot (1) and under the tension spring (2), and then pull it out from the thread guide (3).
- 4、 Check that the bobbin turns clockwise when the thread is pulled.
- 5、 Hold the latch (4) on the bobbin case and insert the bobbin case into the rotary hook.

### 4-3. Threading the upper thread

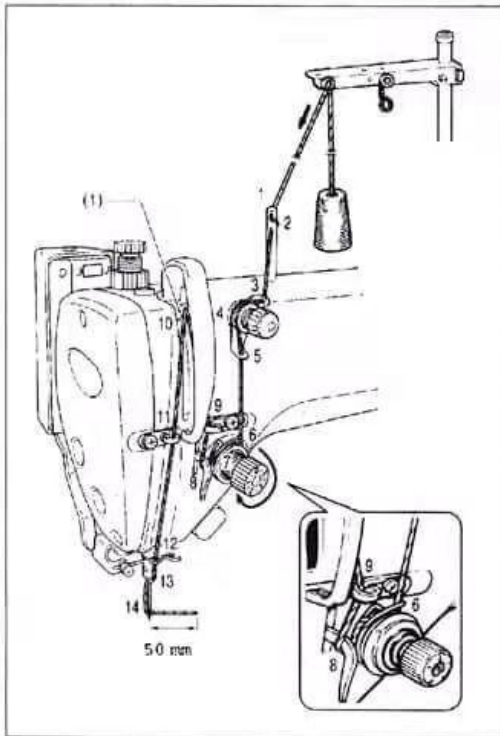

Turn the machine pulley and raise the thread take-up (1) before threading the upper thread.

This will make threading easier and it will prevent the thread from coming out at the sewing start.

### 4-4. Adjusting the stitch length

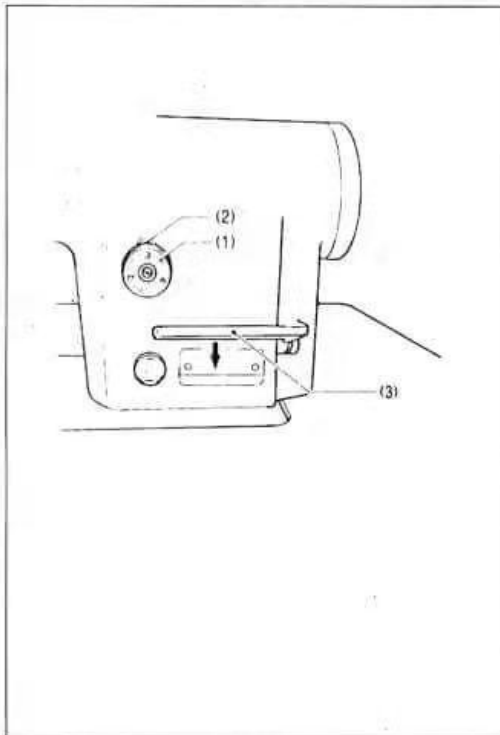

1. Push the dial lock lever (2) up until it clicks to release the lock.

2. Turn the stitch length dial (1) clockwise or counter-clockwise so that the desired stitch length is at the uppermost position on the dial.

- The larger the number, the longer the stitch length will be. (The numbers on the dial are for use as a guide. The length of the finished stitches may vary depending on the type and thickness of material being sewn. Adjust while looking at the finished stitches.)



- When turning the stitch length dial (1) from a larger setting to a smaller setting, it will be easier to turn the dial if the reverse lever (3) is pushed to the halfway-down position.

3. Push the dial lock lever (2) down firmly to lock it.

- \* Check that the stitch length dial (1) does not rotate.

## 5. SEWING

### CAUTION

-  Attach all safety devices before using the sewing machine. If the machine is used without these devices attached, injury may result.
-  Turn off the power switch at the following times.  
The machine may operate if the treadle is depressed by mistake, which could result in injury.
  - When threading the needle
  - When replacing the bobbin and needle
  - When not using the machine and when leaving the machine unattended.
-  Do not touch any of the moving parts or press any objects against the machine while sewing, as this may result in personal injury or damage to the machine.  
Use both hands to hold the machine head when tilting it back or returning it to its original position. If only one hand is used, the weight of the machine head may cause your hand to slip, and your hand may get caught.

### 5-1. Sewing

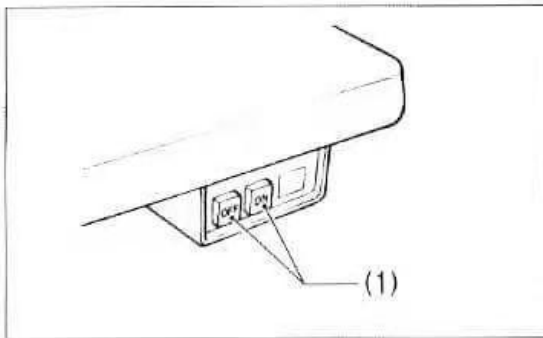

1. Press the ON power switch (1).
2. Depress the treadle to start sewing.

### 5-2. Backtacking

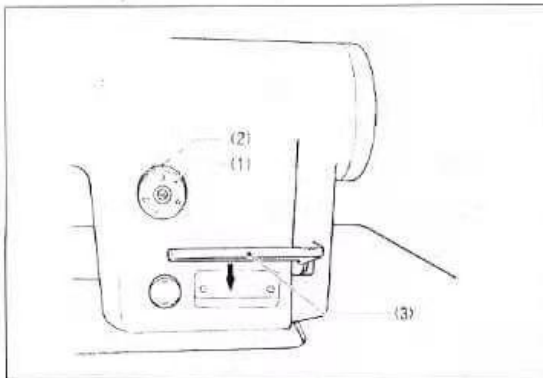

When the reverse lever (3) is pressed during sewing, the feed direction will be reversed. When it is released, the feed direction will return to normal.

## 6. THREAD TENSION

### CAUTION



Turn off the power switch before removing or inserting the bobbin case.  
The machine may operate if the treadle is depressed by mistake, which could result in injury.

### 6-1. Adjusting the thread tension

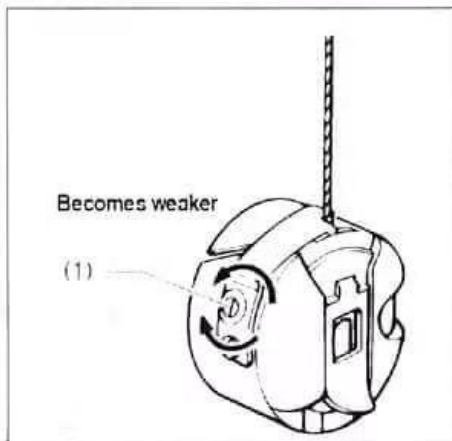
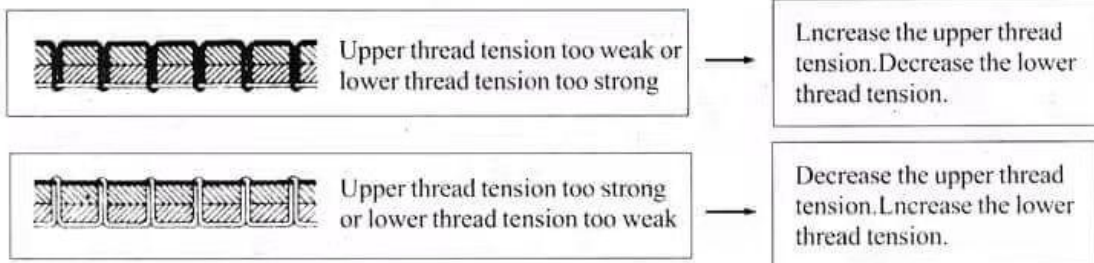
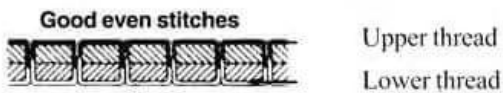

<Lower thread tension>  
Adjust by turning the adjustment screw (1) until the bobbin case drops gently by its own weight while the thread end coming out of the bobbin case is held.

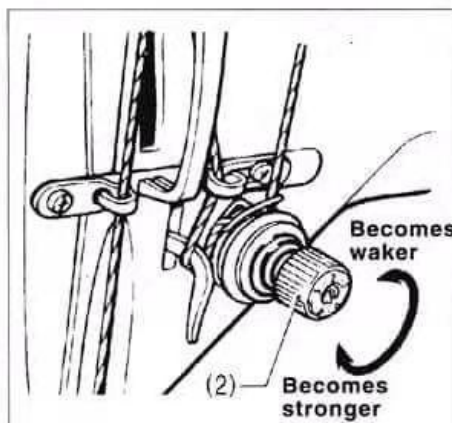

<Upper thread tension>  
After the lower thread tension has been adjusted, adjust the upper thread tension so that a good, even stitch is obtained.

1. Lower the presser foot.
2. Adjust by turning the tension out (2).

## 7. CLEANING

### ⚠ CAUTION

- ⚠ Turn off the power switch before carrying out cleaning.  
The machine may operate if the treadle is depressed by mistake, which could result in injury.
- ⊘ Be sure to wear protective goggles and gloves when handling the lubricating oil and grease, so that they do not get into your eyes or onto your skin, otherwise inflammation can result. Furthermore, do not drink the oil or eat the grease under any circumstances, as they can cause vomiting and diarrhea.  
Keep the oil out of the reach of children.  
Use both hands to hold machine head when tilting it back or returning it to its original. If only one hand is used, the weight of the machine head may cause your hand to slip, and your hand may get caught.

The following cleaning operations should be carried out each day in order to maintain the performance of this machine and to ensure a long service life.

Furthermore, if the sewing machine has not been used for a long period of time, carry out the following cleaning procedures before using it again.

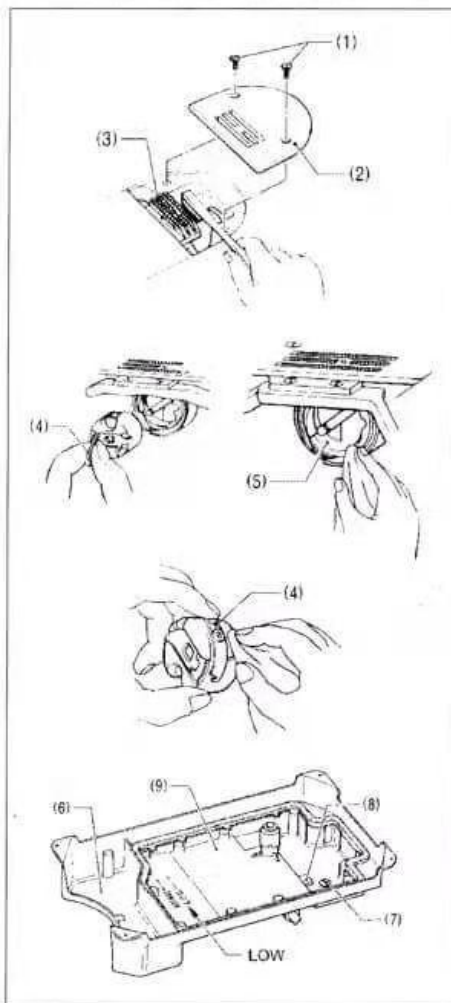

1. Raise the pressed foot.
2. Remove the two screws (1), and then remove the needle plate (2).
3. Use a soft wire brush to clean any dust from the feed dog (3).
4. Install the needle plate (2) with the two screws (1).

5. Tilt back the machine head.
6. Remove the bobbin case (4).
7. Wipe off any dust from the rotary hook (5) with a soft cloth, and check that there is no damage to the rotary hook (5).
8. Remove the bobbin from the bobbin case (4), and clean the bobbin case (4) with a cloth.
9. Insert the bobbin into the bobbin case (4), and then place the bobbin case (4) back into the machine.
10. Wipe with a cloth at the bottom of oil pan (6) accumulation of oil.
11. If the oil level is lower than the baseline <LOW>, be sure to add lubricant. Please use the sewing machine through designated toner.

If the oil is contaminated, please take decentralized oil screw (7) Changing the oil.

Gathered using the cloth to wipe off the magnet (8) and removal of dirt around the net stick in the oil pan (9) on the oil.

## 8. STANDARD ADJUSTMENT

### ⚠ CAUTION

- ⊘ Only trained technicians can carry out the dimension of sewing repair, maintenance and inspection.
- ⚠ And electrical-related repairs, maintenance and inspection of your commission to buy the store Or electrical professionals.
- ⚠ Remove the safety protection device, install again, make sure to install in situon. And check whether the normal function.
- ⚠ Fall sewing machine head, fixed table, be sure to not be so the free movement. Move table to be caught and so prone to foot the accident, leading to people Cause of the accident itself.
- ⚠ The following occurs, turn off the power. And disconnect the power outlet.
  - When the error depresses the pedal, the sewing machine action will lead to injury.
  - Check, adjust and repair
  - A replacement of wearing parts such as the hook
- ⚠ 6. Must be connected to the power switch in the adjustment, be sure to be very careful Observe all safety precautions.

### 8-1. thread springs

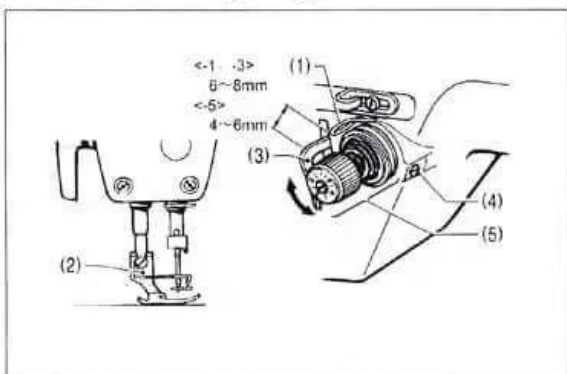

<Pick the line-spring position>

Standard thread springs (1) location is in the presser foot (2) \_ put under state, oriented to in line (3) above

6 ~ 8mm [- [] 05 specifications for the 4 ~ 6mm ] department.

1. Put down the presser foot (2).
2. Loosening the bolt and screw (4)
3. Regulator clamp lever frame (5) rotating the rotating position.
4. Tighten the screws (4).

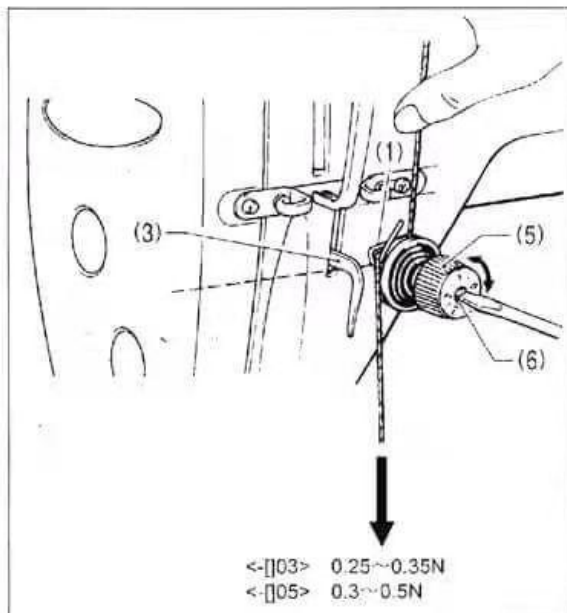

<Pick the line-spring of strength>

Depending on the size, the thread springs (1) standard intensity shown below.

- [] 03 specifications	0.25 ~ 0.35N
- [] 05 specifications	0.30 ~ 0.5N

1. In the clamp leverholder (5), slightly above the place with your fingers to press and hold the noodles do not pulled out.
2. Ramen line down until the threadsprings (1) and line(3) in the bottom of high made consistent, and then measure the thr eadsprings (1) strength.
3. The screwdriver into the clamp screw (6)of the slot. Spin up, theadjustable pick spring (1) strength.

<-[]03> 0.25~0.35N  
<-[]05> 0.3~0.5N

## 8-2、 Cabinet line-oriented R

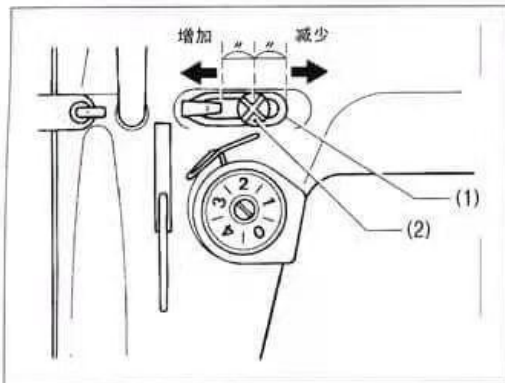

Cabinet line-oriented R (1) of the standard installation location is in the screw (2) in the case thread guide R (1) the center of the adjustable range.

\* Relax screws (2), the mobile chassis line-oriented R (1) to adjust the position section.

- When sewing thick material, the left moving chassis line-oriented R (1).(Thread increased.)
- When sewing book material, the right to move the cabinet line-oriented R (1).(Reduced thread.)

## 8-3、 Presser foot height

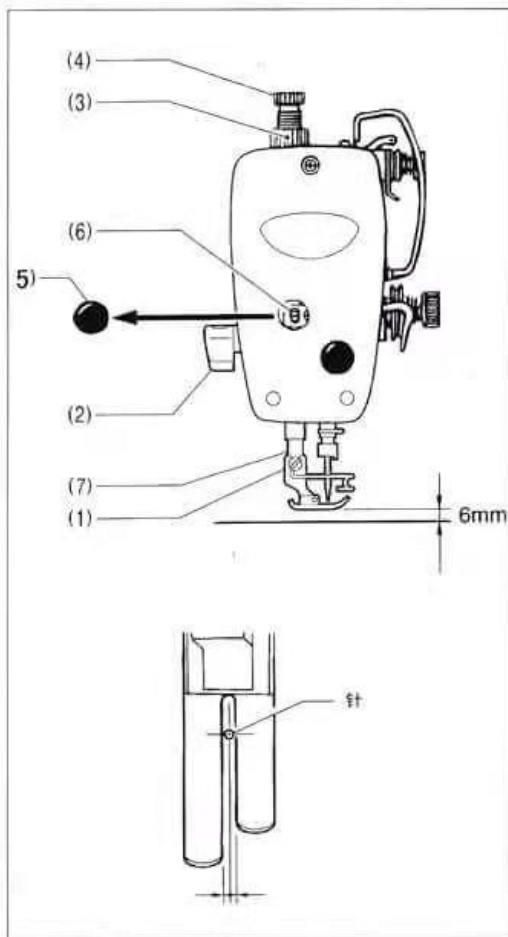

Using the presser foot wrench (2) raise the presser foot (1), the presser foot standard height is 6mm.

- 1、 Loosen the nut (3) and presser foot adjustment bolt (4), do not put pressure on the presser foot.
- 2、 Using the presser foot wrench (2) to raise the presser foot (1).
- 3、 Remove the rubber plug on the panel (5).
- 4、 Loosen the bolt (6), move the bar up and down (7), adjust the presser foot (1) high to 6mm.
- 6、 Install the rubber stopper (5).
- 7、 By pressing the foot adjustment bolt (4) to adjust the foot pressure, tighten the nut (3).

\* After adjusting rotary sewing machines, hand-finished wheels, a confirmed decline in the presser foot needle should be at the middle slot.

## 8-4. Feed dog height

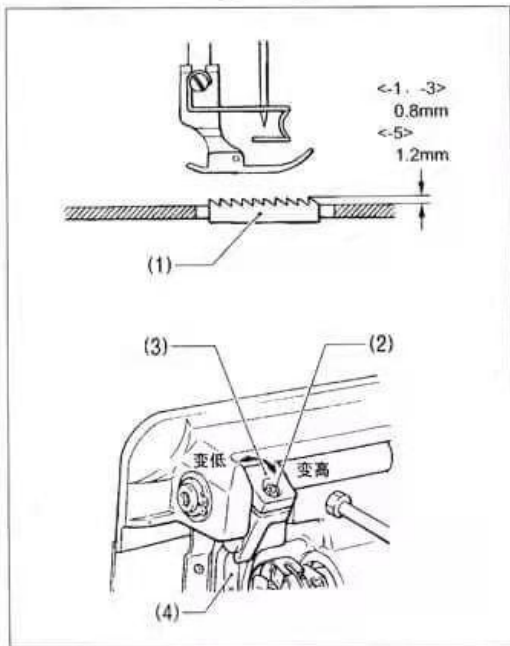

The feed dog (1) to the highest pin-board side, the time of he standard height of a [] specifications should be 0.8mm, on a [] 05 sizes should be 1.2mm.

- 1、 rotary sewing machines. The feed dog (1) to the pin-board side top.
- 2、 Tipped sewing machine head.
- 3、 Loosen the screw (2).
- 4、 Rotate the upper and lower fork lift (3) to tooth rack (4) to be adjusted up and down.
- 5、 Tighten the screws (2).

## 8-5. Feed dog tilt

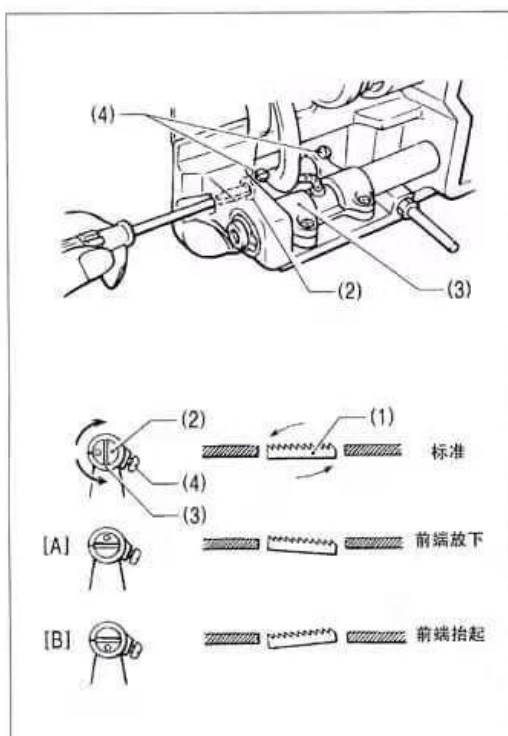

Feed dog (1) is located away from the needle plate to tilt at the standard time frame is the crank side teeth spindle (2) on the stamp (o) and the tooth rack crank (3) mark on the line, to send dog (1) parallel to the needle plate.

- 1、 Turn the sewing machine handwheel. The feed dog (1) to the highest side-pin board position.
- 2、 Tipped sewing machine head.
- 3、 The screws (4) [2] release.
- 4、 According to the standard position in the range of 1 to 90 ° direction of the arrow shelf adjustment teeth Crank eccentric shaft (2).

To prevent wrinkles. Can reduce the feed dog (1) front, (Figure A)

To prevent inconsistencies in the overlapping fabric sewing [suture sub] can be Lift off the feed dog (1) the front end. (Figure B)

- 5、 The screws (4) [2] completely tight.

\* Adjust the feed dog (1) after the tilt. Feed dog (1) changes the height of Change, so please again-time to adjust the feeddog(1) level.

## 8-6. Needle bar height

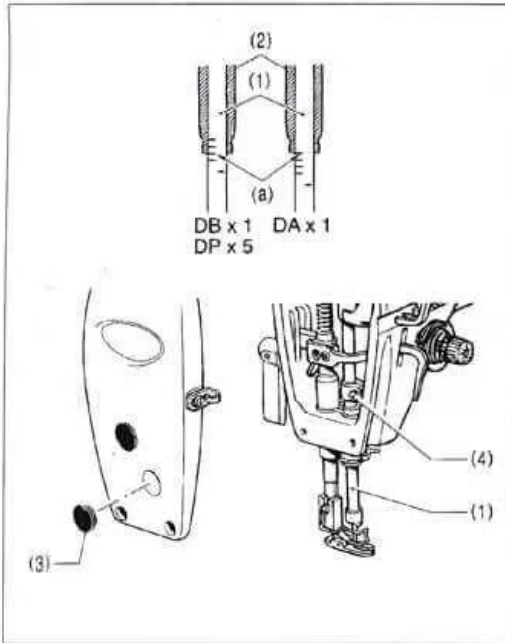

Needle bar (1) reach the lowest position, the needle bar(1) the baseline (a), as shown sleeve with the needle bar(2) to maintain alignment of the lower end.

- 1、 Turn the sewing machine handwheel, so that the needle bar (1) reach the lowest position.
- 2、 Remove the rubber plug on the panel (3).
- 3、 Loosen the bolt (4), the needle bar (1) move up or down to adjust.
- 4、 Tighten the screws (4).
- 5、 Install the rubber stopper (3).

## 8-7. Machine needle and feed synchronization

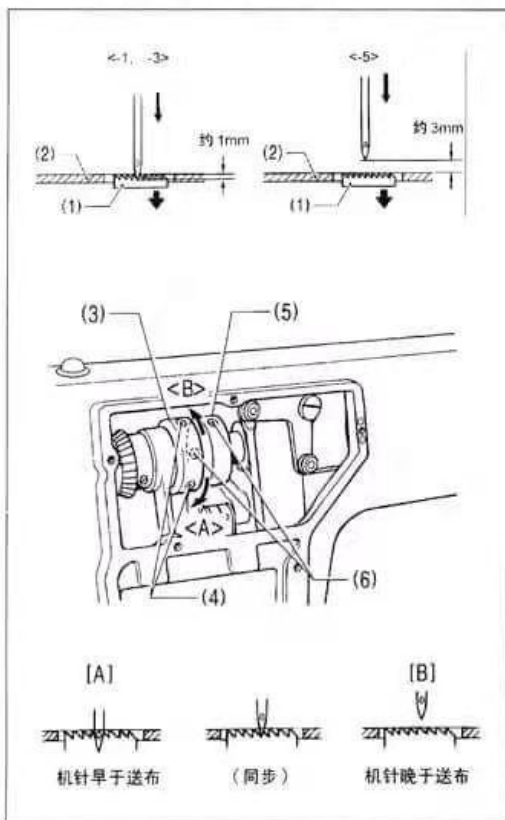

Feed dog (1) beginning from the highest down to the position and the needle plate (2) consistent with surface. When the tip of the needle should be in the position as shown on the left when the standard position.

- 1、 Remove the side panels.
- 2、 Loosen the upper and lower eccentric wheel (3) the screws (4) [2] and the level of eccentric (5) the screws (6) [2], turning down a little eccentric(3) and water ping eccentric (5) to be adjusted.  
(Because the upper and lower eccentric wheel (3) and the level of eccentric wheel (5) is connected using the pin to then, so long as one party can turn. )
- \* To make the needle back on the feed, you can return to the direction of the <A> Needle later than the feed, you can turn the direction of the <B>.
- \* To prevent inconsistencies in the overlapping fabric sewing stitches [sub]. Can The timing adjustment will be hungry later Locust needle.(Figure [B])
- \* To make a good income line, the timing can be additionusted as early as the needle (Fig. [A])
- 3、 After adjusting finished. Tighten the screws (4) and screws (6)

## 8-8. Machine needle and the hook of the synchronization

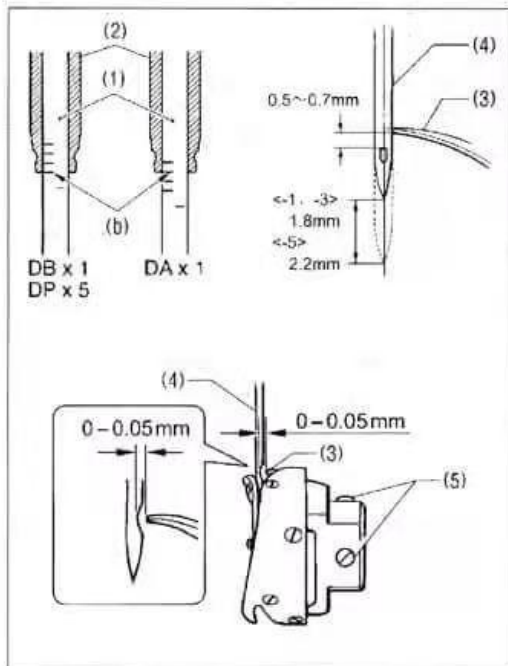

Of 1.8mm (- 0.05 specifications for the 2.2mm) when shown, the baseline (b) with the needle bar bush (2) to maintain alignment of the lower end of when the hook point (3) the needle (4) the center must be consistent. (At this point, with the eye of a needle on the edge of the gap between the hook point is 0.5 ~ 0.7mm.)

- 1、 Turn the sewing machine handwheel, so that the needle bar (1) increased from the lowest position to figure the shows the baseline (b) with the needle bar bush (2) to maintain alignment of the bottom up.
- 2、 Loosen the screws (5) [3], so that the hook point (3) the needle (4) in the heart consistent. At this point, the hook point (3) the needle (4) gap between the 0 ~ 0.05mm.
- 3、 Tighten the screws (5) [3].

## 8-9. Adjusting the rotary hook lubrication amount

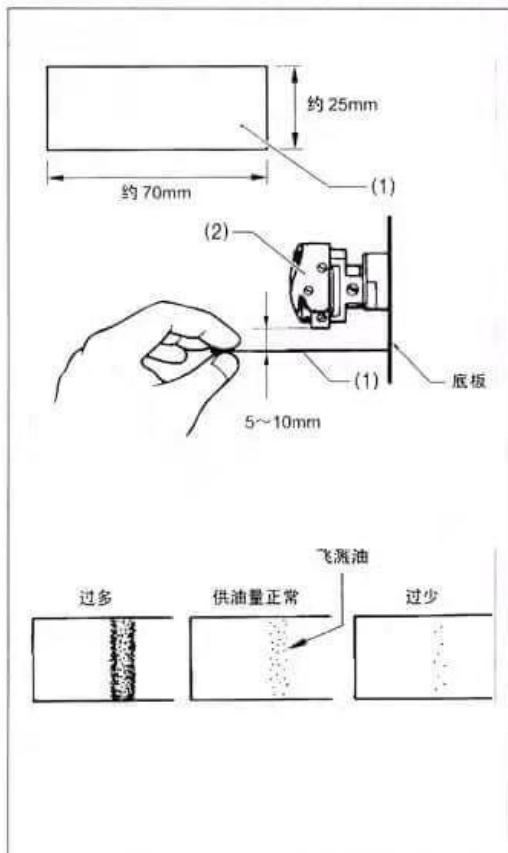

Use the following procedure to check the amount of oil being supplied to the rotary hook when replacing the rotary hook or when changing the sewing speed.

### <Checking the lubrication amount>

- 1、 Remove the thread from all points from the thread take up to the needle. Use the lifting lever to lift the presser foot. Run the machine at the normal sewing speed for approximately 1 minute without sewing any material (following the same start/stop pattern as when actually sewing).
- 2、 Place the lubrication amount check sheet (1) underneath the rotary hook (2) and hold it there. Then run the sewing machine at the normal sewing speed for 8 seconds. (Any type of paper can be used as the lubrication amount check sheet (1).) Check the amount of oil which has spattered onto the sheet. If adjustment is necessary, carry out the following operations in "Adjusting the lubrication amount".

If the lubrication amount does not match the correct amount shown in the illustration at left (if the amount of spattered oil is too much or none at all), turn the adjusting screw (3) clockwise to fully tighten it, turn it back counterclockwise by 2 1/2 turns, and then carry out the following adjustment.

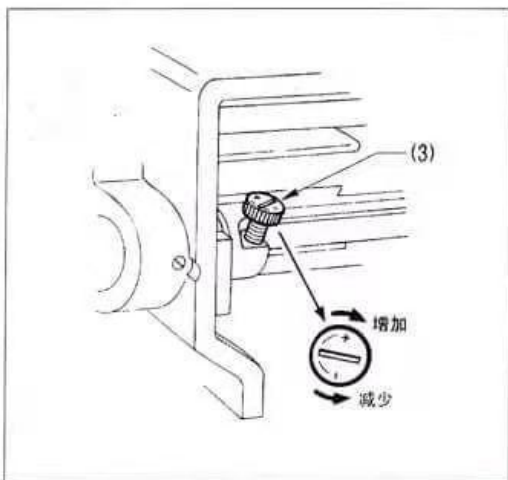

#### <Adjusting the lubrication amount>

- 1、 Tilt back the machine head.
- 2、 Turn the adjusting screw(3)to adjust the lubrication amount.If the rotary hook adjusting screw(3)is turned clockwise,the lubrication amount becomes greater. If the rotary hook adjusting screw(3)is turned counter clockwise,the lubrication amount becomes smaller.
- 3、 Check the lubrication amount again according to the procedure given in "Checking the lubrication amount" above.
  - \* Turn the adjusting screw(3)and check the lubrication amount repeatedly until the lubrication amount is correct.
- 4、 Check the lubrication amount again after the sewing machine has been used for approximately two hours.

### 8-10、 Adjusting the upper cutter

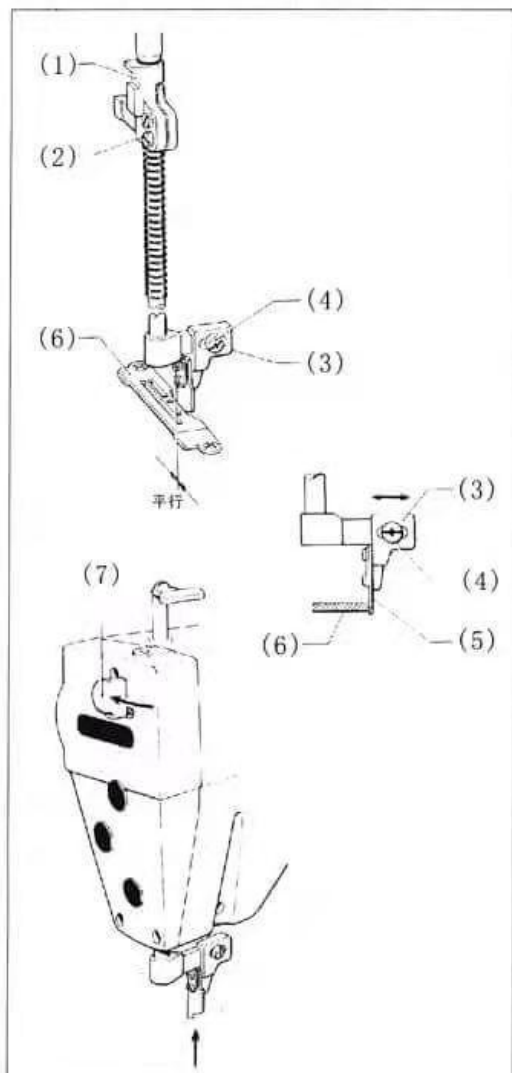

- 1、 Loosen the screw2 of the cutter shaft guide 1, and the screw4 of the cutter guide3.
- 2、 Adjust the side of the upper cutter5 to touch the lower cutter of the needle plate6, and then tighten the cutter flatbed's 3 screw.
- 3、 Adjust the side of the upper knife5 to parallel to lower cutter of the needle plate, and tighten the screw2 of the cutter guide
- 4、 Loosen the screw, and adjust the upper cutter to touch the upper cutter5 of the needle plate6, and tighten the screw.

## 8-11. Adjusting the upper cutter

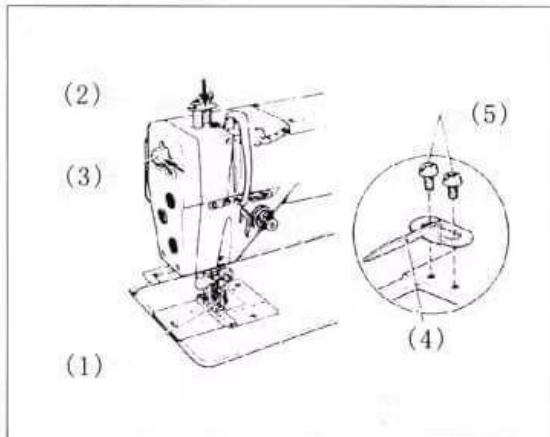

When rising the upper cutter, press the cutter spanner. The upper cutter and the sewing machine will run in the same time.

To operate the upper cutter after the sewing machine stopped

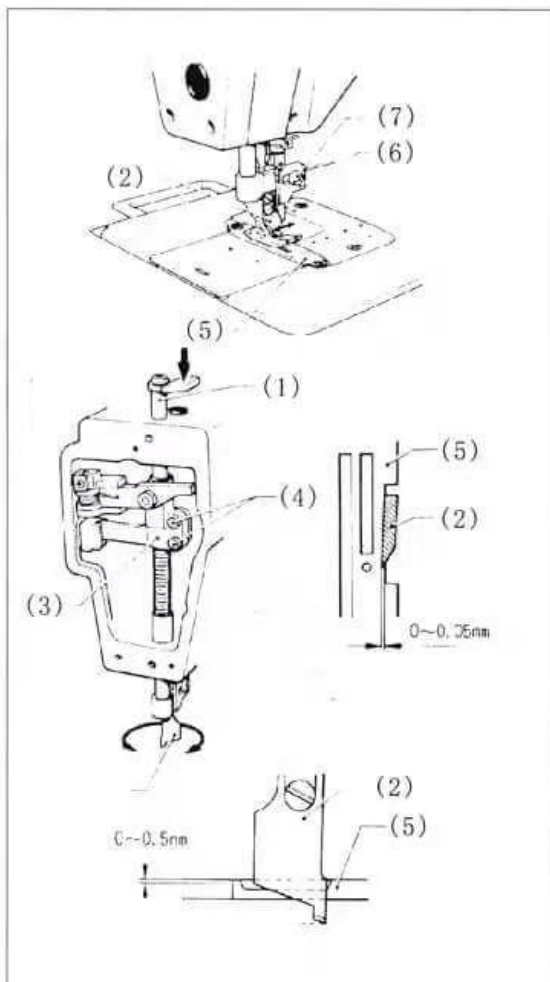

1. Press the upper spanner, and run the wheel to make the upper cutter reaches the lowest point.
2. Loosen the cutter shaft guide's two screws, and make the side of the cutter touch the needle plate. Tighten the screws.
3. Adjust the position of the upper cutter and needle plate as the fig. showed.

## 8-12. Parts chagement

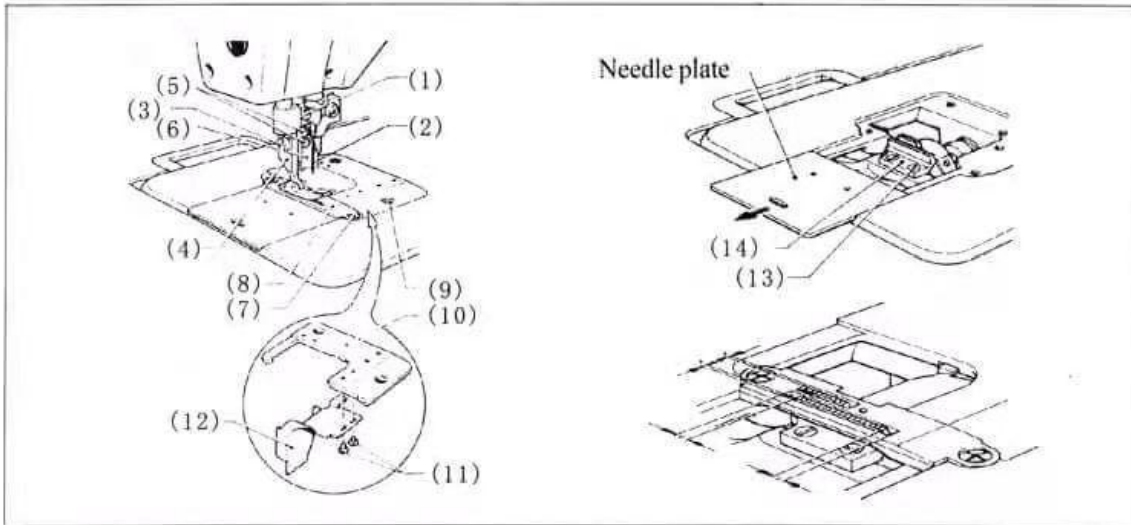





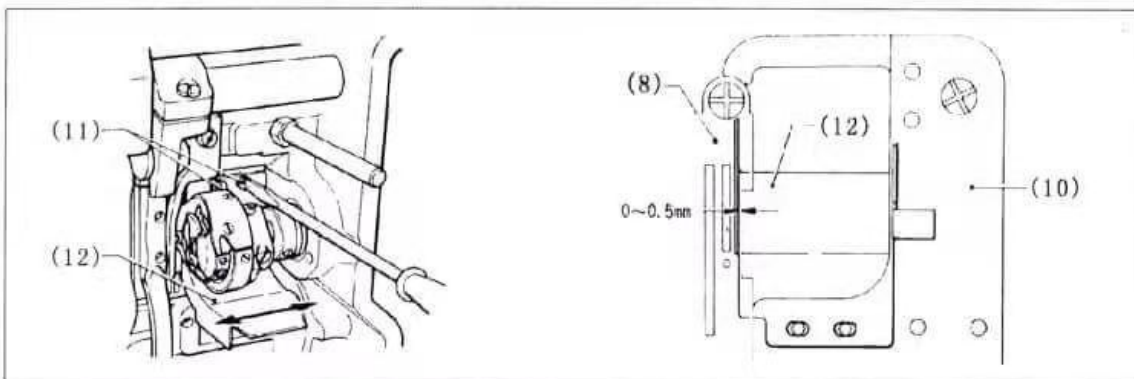



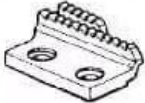
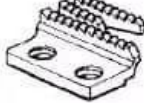

According to the table on page 15 to change different type of parts.

- 1、 Loosen the screw 1 and take off the needle 2.
- 2、 Take off the screw 3 and take off the foot.
- 3、 Loosen the screw 5, and take off the upper cutter 6.
- 4、 Take off the 2 screws 7, and take off the needle plate 8.
- 5、 Take off the 2 screw 9, and cover plate 10.
- 6、 Take off the 2 screws 11, and take off the cutter cover 12 from the cover plate 10.
- 7、 Take off the 2 screws 13, and take off the feed dog 14.

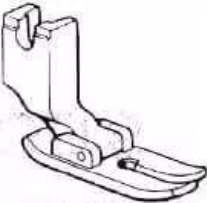
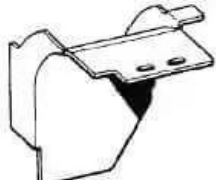

- 1、 Fasten the cutter cover on the back of cover plate 10 by two screws 11.
- 2、 Fasten the feed dog by two screws 13 temporarily.
- 3、 Fasten the cover by 2 screws 9, and the needle plate also fasten by 2 screws 7.
- 4、 Fasten the feed dog and the foot presser by the screw 5 and 3.
- 5、 The feeding screw must be fastened tightly.

## 9. PARTS CHANGEMENT

Feed dog	 <p>S 10583 - 001</p>				 <p>S 10584 - 001</p>	
Needle plate	<p>3/32</p>  <p>S 10569 - 001</p>	<p>1/8</p>  <p>S 10570 - 001</p>	<p>5/32</p>  <p>S 10571 - 001</p>	<p>3/16</p>  <p>S 10572 - 001</p>	<p>1/4</p>  <p>S 10573 - 001</p>	<p>3/8</p>  <p>S 10574 - 001</p>
Foot complete	 <p>S 10576 - 001</p>				 <p>113280 - 001</p>	
Cutter base guide	 <p>S 10609 - 001</p>				 <p>S 10514 - 001</p>	

# 1、机体部件/MACHINE MECHANISM

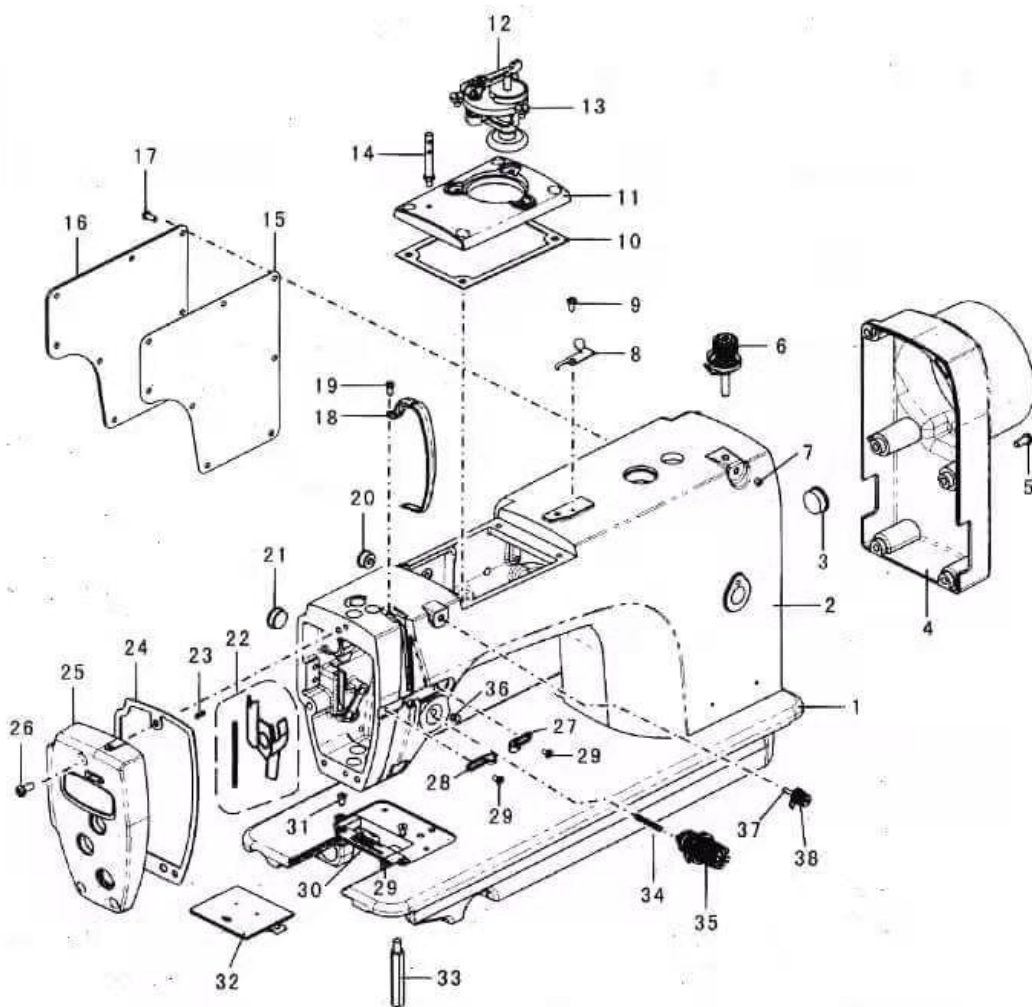

1、机体部件/MACHINE MECHANISM					
序号	物料编码	零件名称	Name of parts	数量	备注
1	777004001	底板	Bed	1	
2	777003001	机头	Arm	1	
3	101011	橡皮塞 $\phi 19$	Rubber, plug ( $\phi 19$ )	1	
4	151004001	电机罩	Motor cover	1	
5	T62501216	螺钉M5 $\times$ 0.8-12	Screw M5X0.8-12	5	
6	113217001	卷线器夹线组件	Crimping device clamp assembly	1	
7	T12500536	螺钉M5 $\times$ 0.8-5	Screw M5X0.8-5	1	
8	113813001	切刀	Cutter	1	
9	T62500616	螺钉M5 $\times$ 0.8-6	Screw M5X6-6	1	
10	777014001	上盖垫片	The upper cover gasket	1	
11	777013001	上盖	loam cake	1	
12	113216001	卷线器组件	Reel Components	1	
13	113812001	卷线器固定螺钉	Screw	3	
14	119035	过线杆	Over pole	1	
15	151090001	后盖板垫片	Gasket for arm side cover	1	
16	113203001	后盖板	Arm side cover	1	
17	T62501216	螺钉M5 $\times$ 0.8-12	Screw group M5X0.8-12	8	
18	108196	挑线杆防护罩	Thread take-up guard	1	
19	T62680812	螺钉SM4.37 $\times$ 40-8	Set screw SM4.37X40-8	1	
20	129057	橡皮塞 $\phi 12.8$	Rubber, plug ( $\phi 12.8$ )	2	
21	108009	橡皮塞 $\phi 15.5$	Rubber, plug ( $\phi 15.5$ )	3	
22	108529	面板挡油板组件	Panel block oil board	1	自配件
22-1	151107001	面板挡油板	oil stopper plate	1	
22-2	108075-150	油线	wick	1	
23	124008	挡油板螺钉SM3.18 $\times$ 44-4	Screw SM3.18X44-4	1	
24	777012001	面板垫片	Gasket for face plate	1	
25	777011001	面板	faceplate	1	
26	T62501216	螺钉SM5 $\times$ 12	Screw SM5X12	3	
27	108194	机壳线勾	Chassis line hook	1	
28	108021	面板线勾	Thread guide on face plate	1	
29	108195	线勾螺钉SM3.57 $\times$ 40-6	Screw SM3.57X40-6	2	
30	129041	针板	Slide plate	1	
31	108062	针板螺钉	Needle plate screw	2	
32	108073	推板组件	Slide plate spring	1	
33	101034	机壳支撑杆	Rod case	4	
34	111025001	松线钉	Loose wire nails	1	
35	108210	夹线器组件	clamp components	1	
36	T15761012	螺钉SM5.95 $\times$ 28-11	Screw SM5.95-28X11	1	
37	113205001	小夹线过线器	Small clamp over the line device	1	
38	113207001	小夹线组件	Small clip cord assembly	1	

## 2、上轴、挑线装置/MAIN SHAFT&THREAD-UP LEVER MECHANISM

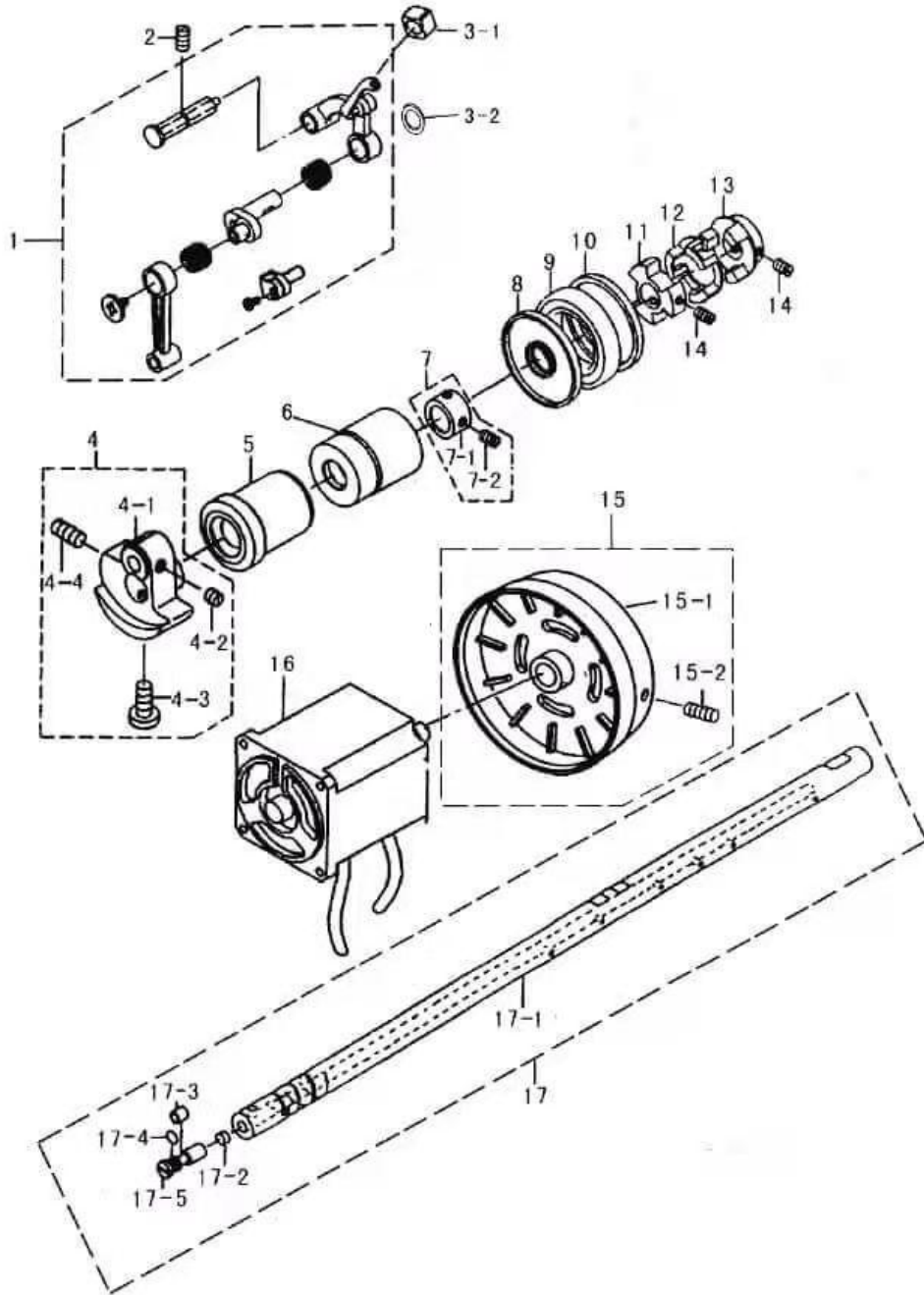

2、上轴、挑线装置/MAIN SHAFT&THREAD-UP LEVER MECHANISM					
序号	物料编码	零件名称	Name of parts	数量	备注
1	151102000	挑线杆组件	Thread take-up lever	1	
2	T13770632	螺钉SM6. 35×40-6	Screw, SM6. 35X40-6	1	
3-1	108060	针杆接头滑块	Slide block	1	
3-2	108055	挑线曲柄垫圈	Washer	1	
4	151101000	针杆曲柄组件	Needle bar crank assy	1	自配件
4-1	151101001	针杆曲柄	Needle bar crank	1	
4-2	T13770612	螺钉SM6. 35×40-6	Screw, SM6. 35X40-6	2	
4-3	151103001	针杆曲柄定位螺钉	Set screw	1	
4-4	151104001	针杆曲柄紧定螺钉SM7. 14×28-10	Set screwSM7. 14X28-10	1	
5	151008001	上轴前套	Arm shaft bushing (left)	1	
6	151010001	上轴中套	Arm shaft bushing (middle)	1	
7	101507	上轴紧圈(大)组件	Collar for arm shaft assy	1	自配件
7-1	101062-1	上轴紧圈(大)	Collar for arm shaft	1	
7-2	T13770412	螺钉SM6. 35×40-4	Screw, SM6. 35X40-4	2	
8	151139001	上轴油封	Oil seal	1	
9	T73690740	轴承(55)	Bearings (55)	1	
10	151028001	轴承垫	Bearing pad	1	
11	122009001	联轴器(A)	Couplings (A)	1	
12	122008001	联轴器橡胶圈	Rubber ring coupling	1	
13	122012001	联轴器(B)	Couplings (B)	1	
14	T12500532	螺钉M5×0.8-5	Screw M5X0.8-5	6	
15	151005000	手轮组件	Handwheel assembly	1	自配件
15-1	151005001	手轮	Handwheel	1	
15-2	T12500832	螺钉M5×0.8-8	Screw, M5X0.8-8	2	
16	199020301	电机	Motor	1	
17	151009000	上轴组件	Arm shaft assy	1	自配件
17-1	777015001	上轴	Arm shaft	1	
17-2	151129001	曲柄油量限制毡	Crank felt limited oil	1	
17-3	151128001	曲柄油量调节销	Fuel adjustment crank pin	1	
17-4	T81004070	O型圈P4	O-ring P4	1	
17-5	151132001	上轴油量调节销	Fuel adjustment pin	1	

### 3、针杆、竖轴、下轴装置/NEEDLE BAR UPRIGHT SHAFT&HOOK DRIVING SHAFT MECHANISM

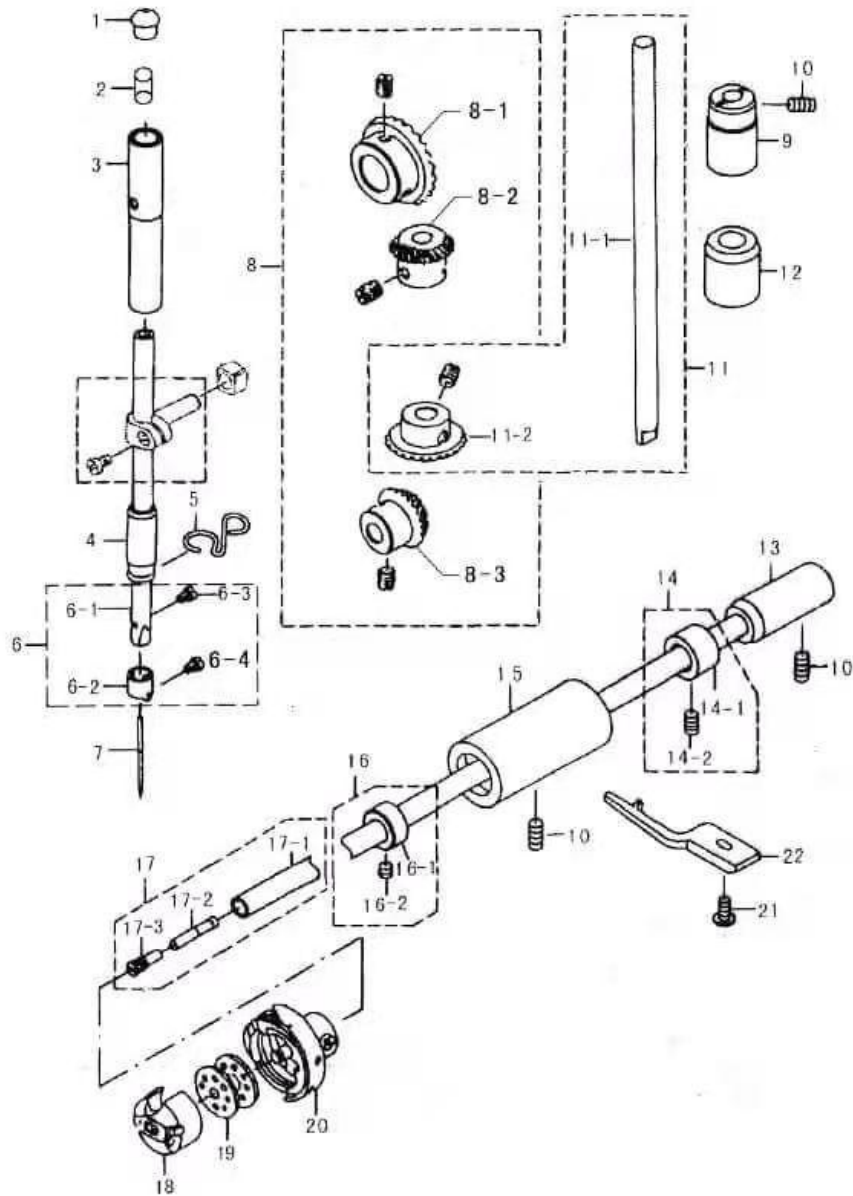

3、针杆、竖轴、下轴装置/NEEDLE BAR UPRIGHT SHAFT&HOOK DRIVING SHAFT MECHANISM					
序号	物料编码	零件名称	Name of parts	数量	备注
1	108010	针杆橡皮塞Φ8	Red,rubber-plug(Φ8)	1	
2	101049	针杆上套毡塞	Felt plug	1	
3	129037	针杆上套	Needle bar bushing (upper)	1	
4	108365	针杆下套	Needle bar bushing (lower)	1	
5	151145001	针杆过线勾-3	Thread guide for bushing (lower)	1	
5	151146001	针杆过线勾-5	Thread guide for bushing (lower)	1	
6	*	针杆组件	Needle bar assy	1	自配件
6-1	129038	针杆	Needle bar	1	
6-2	129048	针杆过线环	Thread guide for needle bar	1	
6-3	T09660432	螺钉SM3. 18×40-4	Screw SM3.18X40-4	1	
6-4	108059	针杆过线环螺钉	Thread guide for needle bar Screw	1	
7	T80211400A	机针-3	Needle	1	
7	T80211800A	机针-5	Needle	1	
8-1	151083001	伞齿轮组件	Bevel gear for vertical shaft assy	1	
8-2	151084001	伞齿轮组件	Bevel gear for vertical shaft assy	1	
8-3	151086001	伞齿轮组件	Bevel gear for vertical shaft assy	1	
9	151095001	竖轴上轴套	Vertical shaft bushing (upper)	1	
10	T13500612	竖轴上轴套紧定螺钉	Screw M5X0.8-6	3	
11	151094000	竖轴组件	Vertical shaft assy	1	自配件
11-1	151094001	竖轴	Vertical shaft	1	
11-2	151085001	竖轴下伞齿轮	Bevel gear for vertical shaft (lower)	1	
12	151096001	竖轴下轴套	Vertical shaft bushing (lower)	1	
13	151093001	下轴后轴套	Hook shaft bushing (right)	1	
14	108483	下轴紧圈组件	Collar for hook shaft assy	1	自配件
14-1	108159	下轴紧圈	Collar for hook shaft	1	
14-2	T13770632	螺钉SM6. 35×40-6	Screw, 6.35X40-6	2	
15	151092001	下轴前轴套	Hook shaft bushing (left)	1	
16	108495	下轴挡油圈组件	Oil under the ring gear shaft assembly	1	自配件
16-1	108173	下轴挡油圈	Oil under the ring gear shaft	1	
16-2	T14680432	螺钉SM4. 37×40-4	Screw,SM4.37X40-4	1	
17	151091000	下轴组件	Rotating hook shaft assy	1	自配件
17-1	151091001	下轴	Rotating hook shaft	1	
17-2	101085	下轴限油芯	Filter	1	
17-3	101084	下轴限油螺钉	Filter screw	1	
18	119209	梭心套(国产)	Bobbin case	1	108382 (进口)
19	108163	梭心	Bobbin	1	
20	119194	旋梭组件-3(国产)	Rotating hook Complete	1	108225 (进口)
21	T09681212	螺钉SM4. 37×40-12	Screw, SM4.37X40-12	1	
22	108162	旋梭定位勾	Rotating hook positsnev	1	

#### 4、压脚装置/PRESSER FOOT MECHANISM

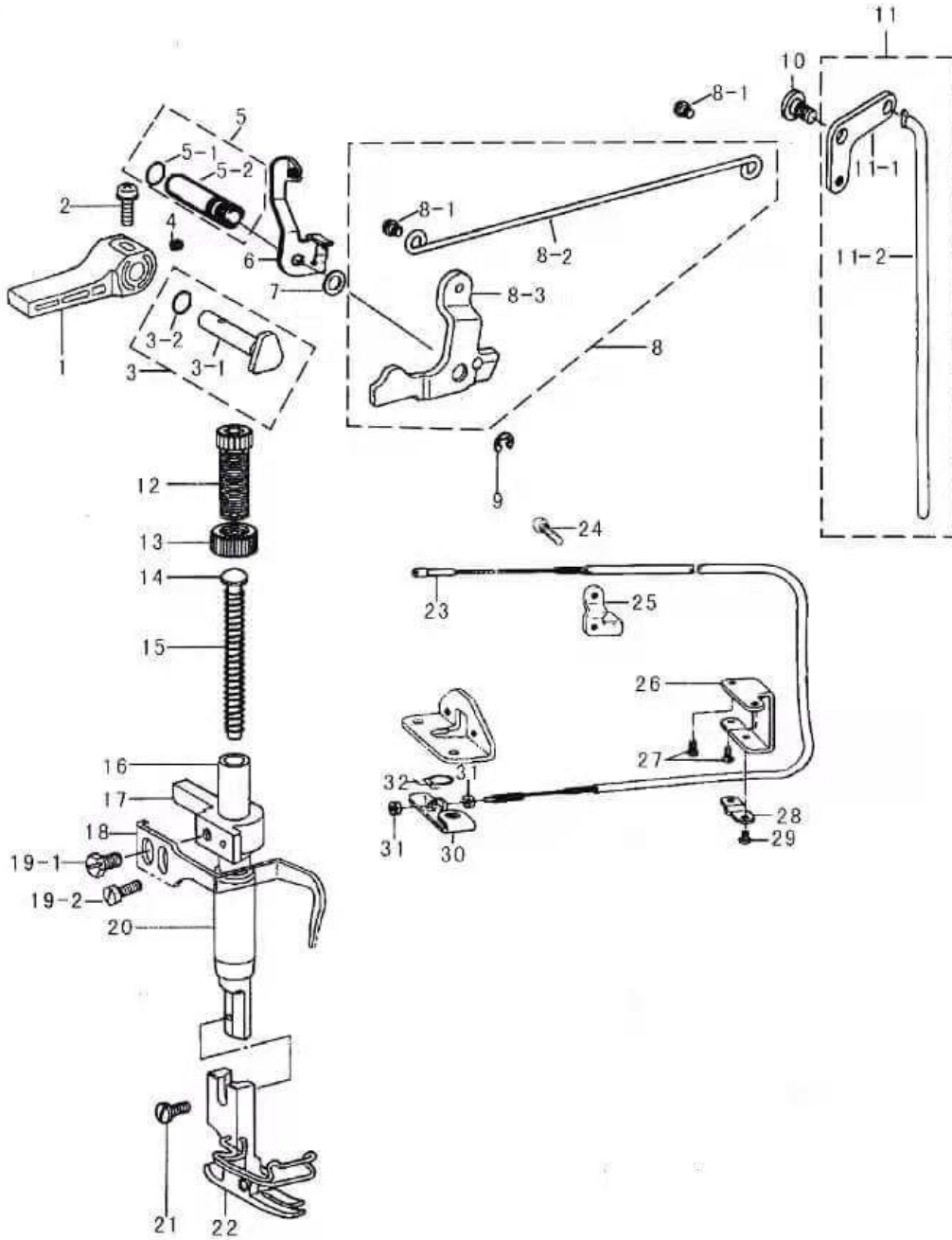

4、压脚装置/PRESSER FOOT MECHANISM					
序号	物料编码	零件名称	Name of parts	数量	备注
1	108038	抬压脚扳手	Presser bar lifter	1	
2	108040	螺钉(带垫圈)M3.5×12	Screw, M3.5X12	1	
3	108478	压紧杆提升凸轮组件	Presser bar lifting cam assy	1	自配件
3-1	108041	压紧杆提升凸轮	Presser bar lifting cam	1	
3-2	T81004070	O型圈P4	O-ring P4	1	
4	T14680632	螺钉SM4.37×40-6	Screw, SM4.37X40-6	1	
5	108471	膝控提升左杠杆销组件	Components of the left lever to enhance sales	1	自配件
5-1	108170	膝控提升左杠杆销O型圈	O-ring	1	
5-2	119009	膝控提升左杠杆销	The left lever to enhance sales	1	
6	119010	松线架	Loose wire rack	1	
7	108029	垫圈	Washer	1	
8	151150000	膝控提升左杠杆组件	Enhance the control lever assembly left knee	1	自配件
8-1	108034	段螺钉SM4.76	Screw, SM4.76	2	
8-2	101159	膝控连杆	Knee link	1	
8-3	119008	膝控提升左杠杆	Raise the left knee lever control	1	
9	T48040342	挡圈E4	Ring E4	1	
10	119012	后杠杆轴位螺钉	Screw	1	
11	151063000	抬压脚顶杆组件	Presser foot lift ejector assembly	1	自配件
11-1	108035	膝控提升右杠杆	Raise the right knee lever control	1	
11-2	151063001	抬压脚顶杆	Presser foot lift mandrel	1	
12	108024	调压锁紧螺钉	Pressure regulating thumb screw	1	
13	108043	调压锁紧螺母	Lock nut	1	
14	108025	压紧杆弹簧导柱	Presser bar guide	1	
15	113558001	压紧杆弹簧-3	Presser spring	1	
15	108026	压紧杆弹簧-5	Presser spring	1	
16	108022	压紧杆	Presser bar	1	
17	129055	压紧杆导架	Presser bar lifting bracket	1	
18	129052	大线勾	Upper thread guide	1	
19-1	T62680712	导架螺钉SM4.37×40-7	Screw, SM4.37X40-7	1	
19-2	101018	大线勾螺钉	Screw	1	
20	108023	压紧杆轴套	Presser bar bushing	1	
21	108027	压脚螺钉SM3.57×40-10	Screw, SM3.57X40-10	1	
22	119015	压脚组件-3	Presser foot complete	1	
22	119016	压脚组件-5	Presser foot complete	1	
23	777019001	松线钢绳	Loose wire rope	1	
24	T62671612	螺钉SM3.57×40-16	Screw, SM3.57X40-16	2	
25	405018	松线钢绳架板	Loose wire rope supporting board	1	119100
26	151035001	松线钢绳座	Loose wire rope Block	1	119098
27	T62670812	螺钉SM3.57×40-8	Screw, 3.57X40-8	2	
28	405017	松线固定板	Loose wire fixed plate	1	119099
29	T62670612	螺钉SM3.57×40-6	Screw, SM3.57X40-6	2	
30	151036001	松线座	Song Line Block	1	119095
31	119097	螺母4.76	Nut SM4.76	2	
32	151030001	松线复位弹簧	Loose wire return spring	1	

## 5、送料装置/FEED MECHANISM

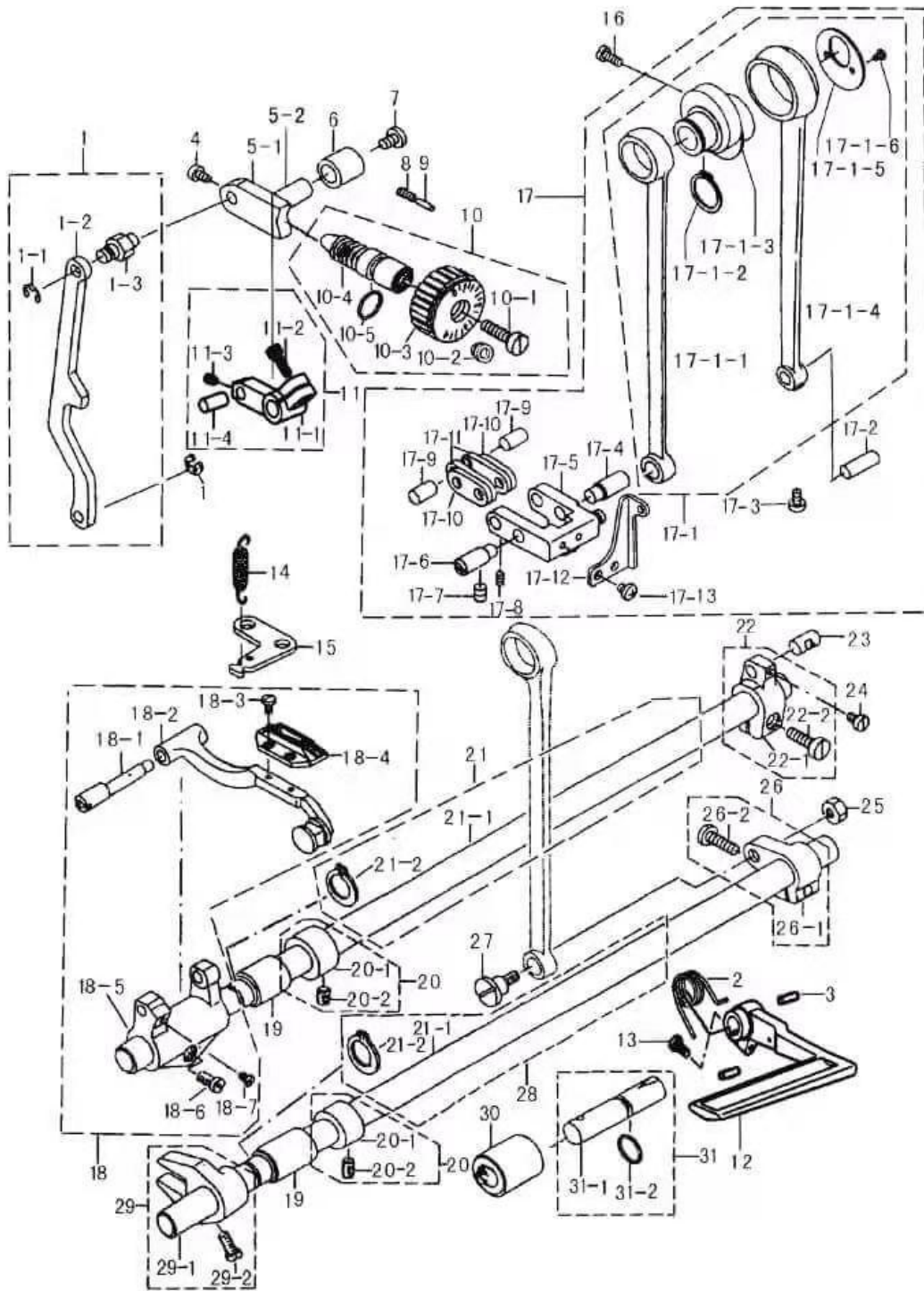

5、送料装置/FEED MECHANISM					
序号	物料编码	零件名称	Name of parts	数量	备注
1	151045000	倒送料连杆组件	Feed back link assy	1	自配件
1-1	T48050342	挡圈E5	Circlip E5	2	
1-2	151045001	倒送料连杆	Feed back link	1	
1-3	151044001	倒送料连杆销	Link feed pins down	1	
2	113608001	倒缝扳手复位簧	Reset spring feeding wrench down	1	
3	101166	倒缝扳手限位销	Backstitch wrench limit sales	2	
4	T62670812	螺钉SM3. 57×40-8	Screw, SM3. 57X40-8	1	
5-1	151052001	送料调节器	Feed regulator	1	
5-2	151054001	送料调节器轴	Feed regulator shaft	1	
6	151053001	送料调节器轴套	Feed adjuster sleeve	1	
7	151046001	送料调节器紧固螺钉	Screw	1	
8	101116	止动销弹簧	Spring for stopper pin	1	
9	108100	止动销	Stopper pin	1	
10	151039000	针距标盘组件	Dial assy	1	自配件
10-1	108150	针距标盘螺钉SM4. 76	Screw SM4. 76	1	
10-2	101271	针距标盘套	Rubber plug	1	
10-3	108331	针距标盘-5	Dial	1	
10-4	151039001	针距调节螺杆	Screw	1	
10-5	108151	针距调节螺杆O型圈	O-ring	1	
11	113610001	操纵杆托架组件	Lever bracket assembly	1	自配件
11-1	113611001	操纵杆托架	Joystick Bracket	1	
11-2	T18501636	螺栓M5×16	Screw M5X16	1	
11-3	T12500536	螺钉M5×5	Screw M5X5	1	
11-4	113612001	倒送料曲柄销	Feeding crank pin down	1	
12	113340001	倒缝扳手	Backstitch wrench	1	
13	T62501416	螺钉M5×14	Screw M5X14	1	
14	151040001	倒送料拉簧	Feeding tension spring back	1	
15	151041001	拉簧固定板	Tension spring fixing plate	1	
16	151055001	送布凸轮螺钉SM6. 35×40-11	Screw SM6. 35X40-11	2	
17	151024000	送布曲柄组件	Feed rock shaft crank assy	1	自配件
17-1	151012000	送布凸轮组件	Feed cam assembly	1	
17-2	151020001	送布连杆销	Feed rod pin	1	
17-3	108130	送布连杆螺钉SM3. 57×40-4	Screw SM3. 57X40-4	1	
17-4	151050001	送料摆动板座右销(长)	Feeding off the right swing board seat	1	
17-5	151016000	送料摆动板座组件	Block feed swing plate assembly	1	
17-6	151051001	送料摆动板座右销(短)	Feeding off the swing board seat left	1	
17-7	T14760632	螺钉SM5. 95×28-6	Screw SM5. 95X28-6	2	
17-8	T13670612	螺钉SM3. 57×40-6	Screw SM3. 57X40-6	3	
17-9	151023001	短摆动板连接销	Short swing seat connecting pin board	2	
17-10	151019001	送料短摆动杆	Feeding short swing lever	2	

## 5、送料装置/FEED MECHANISM

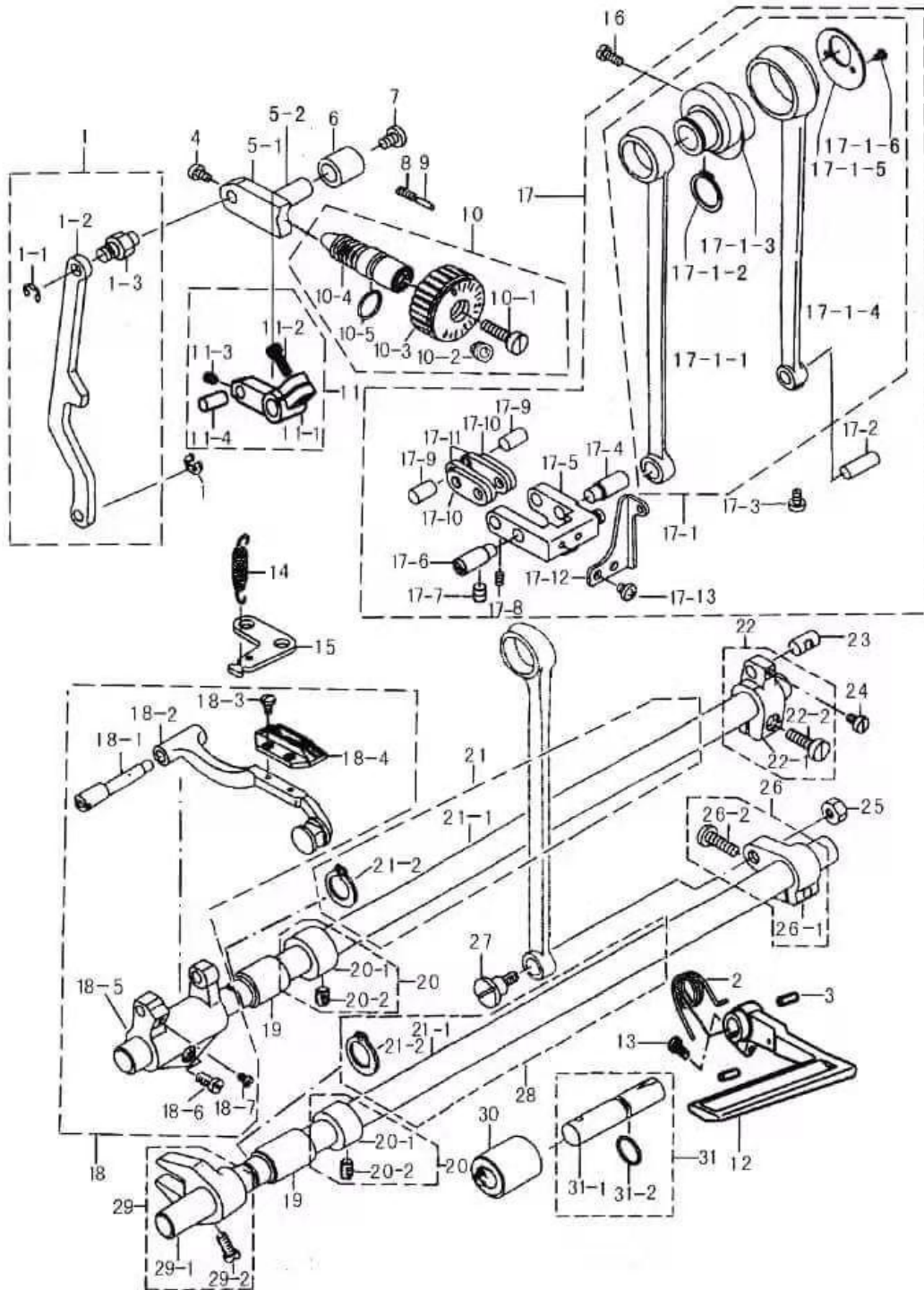

5、送料装置/FEED MECHANISM					
序号	物料编码	零件名称	Name of parts	数量	备注
17-11	151021001	送料长摆动杆	Feeding long swinging rod	2	
17-12	151025001	摆动板座复位板	Reset board board seat swing	1	
17-13	T62680612	螺钉SM4. 37×40-5	Screw SM4. 37X40-5	2	
18	151071000	牙架曲柄组件	Tooth rack crank assembly	1	自配件
18-1	151072001	牙架曲柄偏心轴	Eccentric crank shaft tooth rack	1	
18-2	151066001	牙架组件	Tooth rack components	1	
18-3	108146	送布牙螺钉SM3. 18×44	Screw SM3. 57X40-6	2	
18-4	108145	送布牙-3	Feed dog -3	1	
18-4	108322	送布牙-5	Feed dog -5		
18-5	151071001	牙架曲柄	Crank tooth rack	1	
18-6	T62711412	螺钉SM4. 76×32-14	Screw SM4. 76X32-14	2	
18-7	T62680612	螺钉SM4. 37×40-6	Screw SM4. 37X40-6	1	
19	151060001	送布、拾牙轴前轴套	Feed, before the lift shaft sleeve teeth	2	
20	101537	拾牙、送布轴紧圈组件	Tight circle components	2	自配件
20-1	101062	拾牙、送布轴紧圈	Tight circle	2	
20-2	T13770412	螺钉SM6. 35×40-4	Screw SM6. 35X40-4	4	
21	151061000	送布轴组件	Feed rock shaft assy	1	自配件
21-1	151061001	送布轴	Feed rock shaft	1	
21-2	T48150142	送料、拾牙轴卡簧	C-type stop ring	1	
22	*	送布曲柄组件	Feed rock shaft crank assy	1	自配件
22-1	151024001	送布曲柄	Feed rock shaft crank (right)	1	
22-2	101130	送布曲柄螺钉	Screw	1	
23	151022001	送布曲柄连接销	Feed crank pin connection	1	
24	T62711412	螺钉SM4. 76×32-14	Screw SM4. 76X32-14	1	
25	108111	拾牙连杆轴位螺母7. 14×28	Nut SM7. 14X28	1	
26	151026000	拾牙曲柄组件	Tooth crank lift components	1	自配件
26-1	151026001	拾牙曲柄	Tooth crank lift	1	
26-2	101130-1	拾牙曲柄螺钉	Screw	1	
27	151027001	拾牙连杆轴位螺钉	Screw	1	
28	151062000	拾牙轴组件	Teeth lift shaft assembly	1	自配件
28-1	151062001	拾牙轴	Lift shaft tooth	1	
21-2	T48150142	送料、拾牙轴卡簧	C-type stop ring	1	
29	151034000	拾牙叉组件	Teeth fork lift components	1	自配件
29-1	151034001	拾牙叉	Fork lift teeth	1	
29-2	T62681012	螺钉SM4. 37×40-10	Screw SM4. 37X40-10	1	
30	151042001	倒送料轴轴套	Down feed shaft sleeve	1	
31	151043000	倒送料轴组件	Down components of the feed axis	1	自配件
31-1	151043001	倒送料轴	Down feed axis	1	
31-2	T81007070	O型圈P7	O-ring P7	1	

## 6、切刀部件/UPPER KNIFE MECHANISM

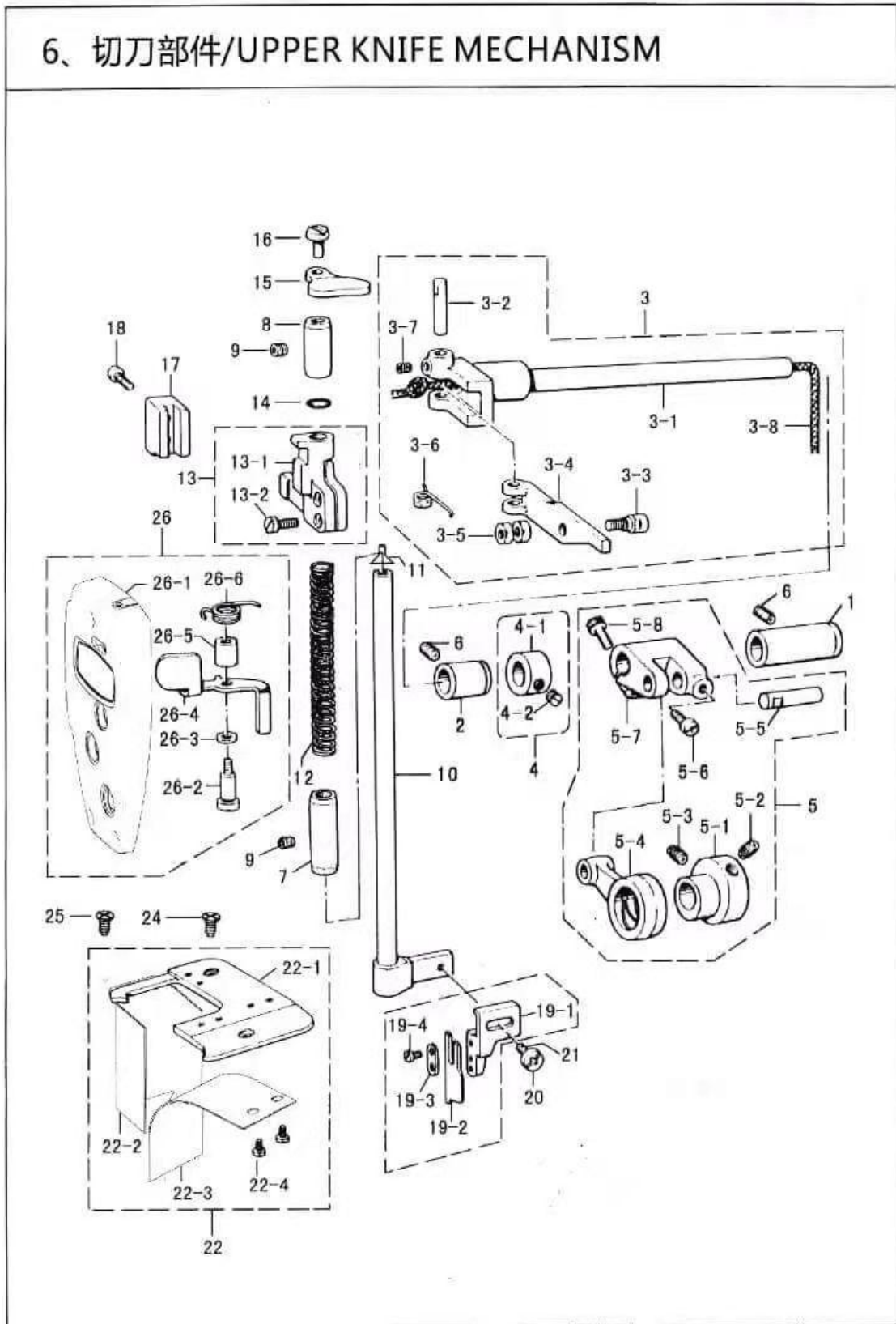

6、切刀部件/UPPER KNIFE MECHANISM					
序号	物料编码	零件名称	NAME OF PARTS	用量	备注
1	129030	切刀摆动轴套L	Rock shaft bush L	1	
2	129031	切刀摆动轴套R	Rock shaft bush R	1	
3	*	切刀摆动轴组件	Rock shaft w/screw	1	
3-1	129010	切刀摆动轴	Rock shaft	1	
3-2	129011	驱动曲柄销	Pin	1	
3-3	129014	切刀离合销	Pin	1	
3-4	129013	离合柄	Clutch bracket	1	
3-5	129049	螺母	Nut3 SM2.56	1	
3-6	129012	离合柄弹簧	Spring	1	
3-7	T14680432	紧定螺钉SM4.37×40	Set screw SM4.37	1	
3-8	*	油线L=300		1	
3-9	*	扎带		1	
4	*	驱动轴紧圈组件	Set screw collar assy	1	
4-1	129003	驱动轴紧圈	Set screw collar	1	
4-2	T14760632	紧定螺钉SM5.95×28-6	Set screw sm5.95	2	
5	777020001	切刀驱动凸轮组件	Knife eccentric wheel assy	---	
5-1	129006	切刀驱动凸轮	Knife eccentric wheel	1	
5-2	T15761122	螺钉SM5.95×28-11	Set screw SM5.95	1	
5-3	T13761032	螺钉SM5.95×28-10	Set screw SM5.95	1	
5-4	129007	摆动连杆	Rock connecting rod	1	
5-5	129009	摆动曲柄销	Pin	1	
5-6	T62711012	螺钉SM4.76×32-10	Set screw SM4.37	1	
5-7	777021001	摆动曲柄	Rock arm	1	
5-8	T62681412	螺钉SM4.37×40-14	Set screw SM4.37	2	
6	T13760612	紧定螺钉SM5.95×28	Set screw SMSM5.95	2	
7	129021	切刀下轴套	Knife shaft bush D	1	
8	129020	切刀上轴套	Knife shaft bush U	1	
9	T14500332	紧定螺钉SM4.37×40	Set screw SM4.37	2	
10	129016	切刀轴	Knire shaft	1	
11	116293	压紧杆防油罩	Resser bar	1	
12	129017	切刀轴弹簧	Spring assy	1	
13	*	切刀轴导向架组件	Knife shaft guide assy	1	
13-1	129015	切刀轴导向架	Knife shaft guide	1	
13-2	T62681212	螺钉SM4.37×40-12	Bolt, SM4.37X40	1	
14	116298	缓冲垫	O ring P9	1	
15	413003	切刀轴扳手	Upper knift set lever	1	
16	129047	切刀轴扳手螺钉	Screw	1	
17	129028	切线轴导轨	Knife shaft guide	1	
18	130040	螺钉SM3.57×40-13	Screwc, SM3.57X40	2	
19	*	切刀架组件	Knife holder	1	

## 6、切刀部件/UPPER KNIFE MECHANISM

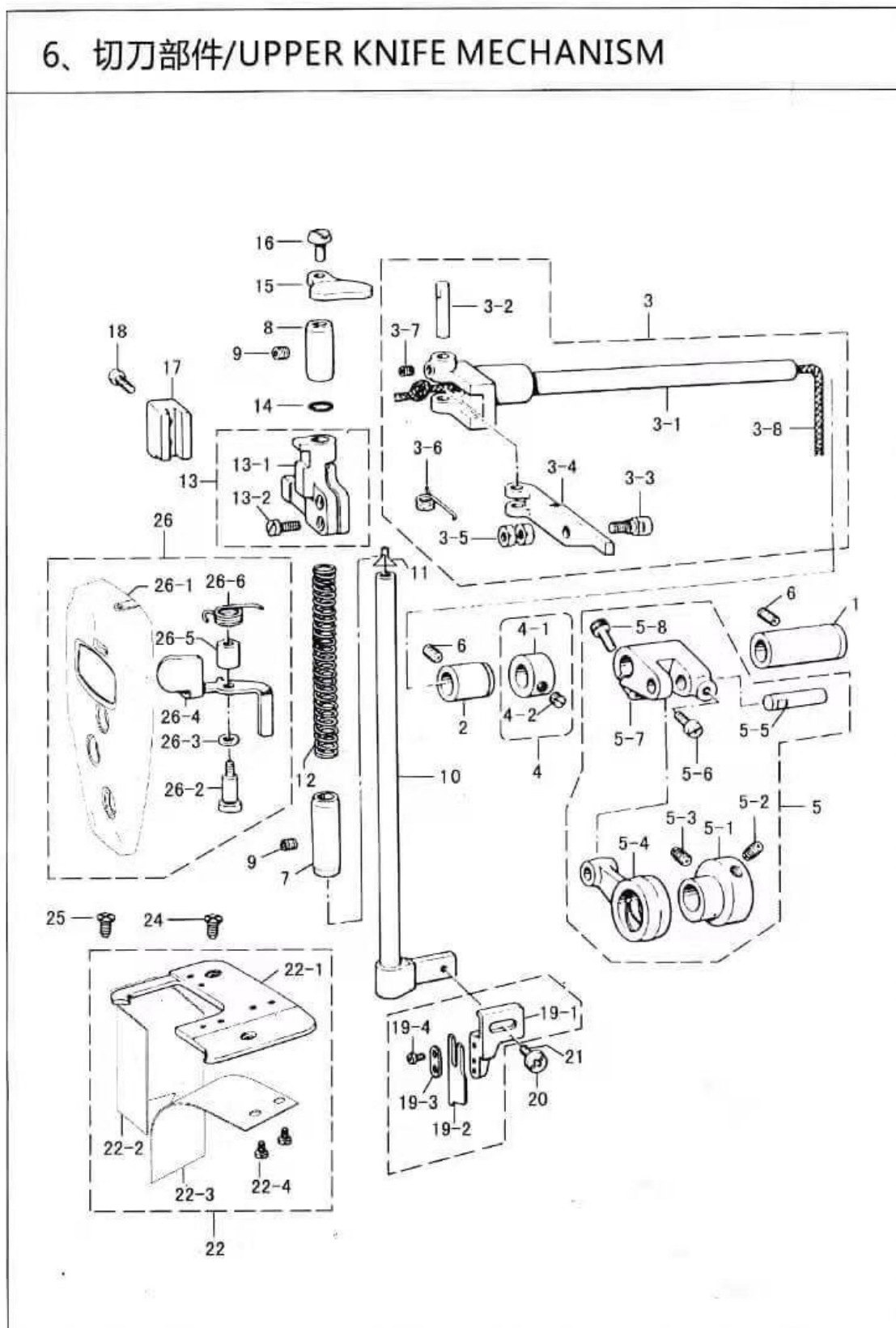

6、切刀部件/UPPER KNIFE MECHANISM					
序号	物料编码	零件名称	NAME OF PARTS	用量	备注
19-1	129018	切刀架	Knife holder	1	
19-2	129043	切刀	Upper knift	1	
19-3	413002	切刀压板	Knife washer	1	
19-4	108059	切刀压板螺钉SM3.18	Screw bind SM3.18	2	
20	T62711012	螺钉SM4.76×32-10	Set screw SM4.37	1	
21	115080	垫圈	Washer plain	1	
22	777018000	右推板组件	Needle plate assy	1	
22-1	777018001	右推板	Needle plate	1	
22-2	777016001	排屑罩	Material cover	1	
22-3	T62300312	螺钉M3×0.5-3	Bolt M3X0.5	2	
23	777017001	排屑罩	Material cover	1	
24	108062	右推板螺钉	Needle plate screwc	2	
25	115243	排屑罩螺钉	Material cover screwc	1	
26	777011000	面板组件	Face plate assy	1	
26-1	777011001	面板	Face plate washer plain	1	
26-2	129004	复位扳手轴位螺钉	Shouler screwc SM4.76	1	
26-3	108135	扳手轴位螺钉垫圈	Shouler screwc	2	
26-4	129024	复位扳手	Clear lever	1	
26-5	129025	扳手弹簧复位套	Collar	1	
26-6	129026	复位扳手弹簧	Spring	1	

## 7、自动切线装置/THREAD TRIMMER MECHANISM

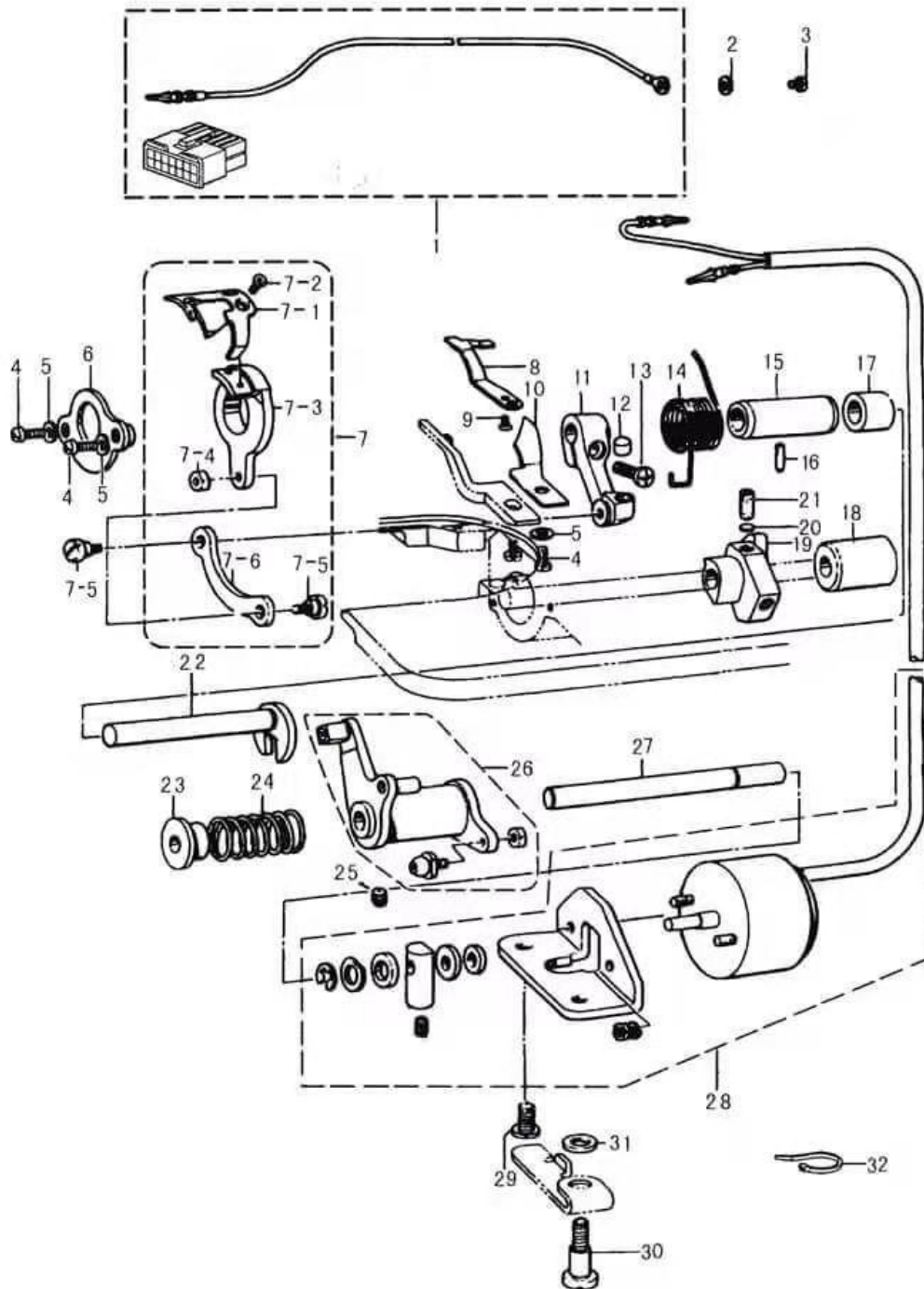

7、自动切线装置/THREAD TRIMMER MECHANISM					
序号	物料编码	零件名称	Name of parts	数量	备注
1	系统配送	接地线组件	Ground wire assembly	1	
2	405013	垫圈	Washer	1	
3	T62500612	螺钉M5×6	Screw, M5X6	1	
4	T62680812	螺钉SM4. 37×40-8	Screw, SM4. 37X40-8	3	
5	119075	垫圈	Washer	3	
6	119043	刀架压板组件	Knife bracket presser assy	1	
7	108530	动刀组件	Knife assembly	1	自配件
7-1	119044	动刀	Motorial knife	1	
7-2	119045	螺钉4. 37	Screw, SM4. 37	1	
7-3	119042	刀架	Knife bracket	1	
7-4	119048	螺母SM4. 37	Nut SM4. 37	1	
7-5	119047	螺钉4. 37	Screw, SM4. 37	1	
7-6	151201001	刀架连杆	Knife shaft connecting rod	1	
7-5	119047	螺钉SM4. 37	Screw, SM4. 37	1	
8	119039	固定刀	Fixed knife	1	
9	119040	固定刀螺钉SM3. 57	Screw, SM3. 57	1	
10	151017001	分线器	Thread partition	1	
11	119049	切刀驱动曲柄	Thread shear rock arm	1	
12	119050	驱动曲柄止动块	Positioning block	1	
13	T62711412	螺钉SM4. 76×28-14	Screw, SM4. 76X28-14	1	
14	119051	切刀曲柄弹簧	Spring	1	
15	151056001	切线轴套	Thread shear shaft bush	1	
16	119055	切线轴套螺钉4. 37	Screw, SM4. 37	1	
18	151089001	下轴中轴套	Axis in the sleeve under the	1	
19	119037	切线凸轮	Thread shear cam	1	
20	119038	切线凸轮垫	Thread shear cam mat	1	
21	T14771032	螺钉SM6. 35×40-10	Screw, SM6. 35X40-10	1	
22	151037001	切刀驱动曲柄轴	Thread shear rock arm shaft	1	
23	119060	扭簧端盖	Spring cover	1	
24	119061	切线凸轮复位弹簧	Spring	1	
25	T14770632	螺钉SM6. 35×40-6	Screw, SM6. 35X40-6	1	
26	119083	切线凸轮曲柄组件	Thread shear cam rock arm assy	1	
27	119059	切刀驱动轴	Thread shear shaft	1	
28	151038001	切线电磁铁组件	Solenoid components tangent	1	119063
29	T62770632	螺钉SM6. 35×40-6	Screw, SM6. 35X40-6	1	
30	119067	螺钉SM6. 35×40	Screw, SM6. 35X40	1	
31	T25060232	切线电磁铁架垫圈	Washer	1	405011
32	330224	扎带	Cord holder 1M	1	

## 8、自动倒缝装置/AUTOMATIC REVERSE MECHANISM

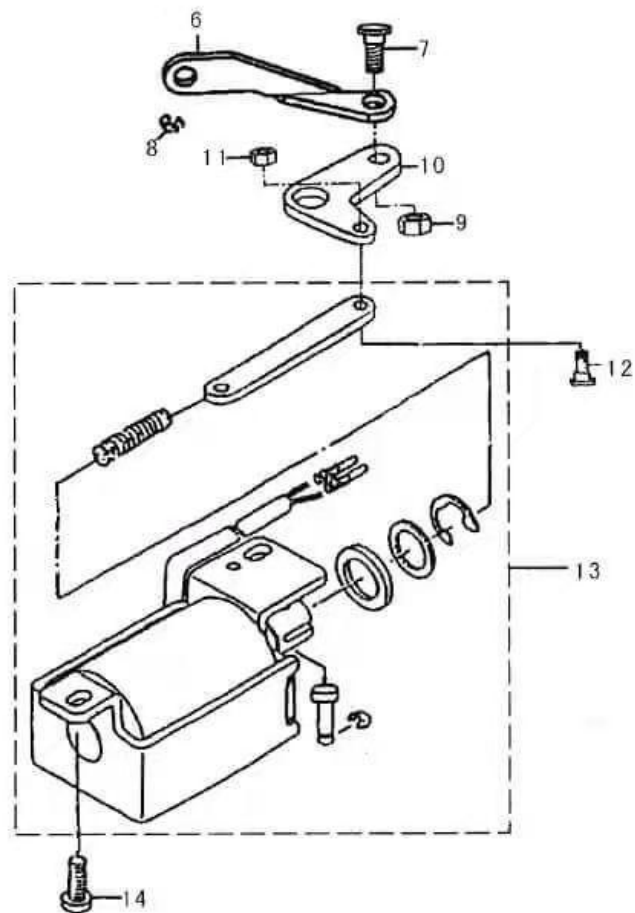
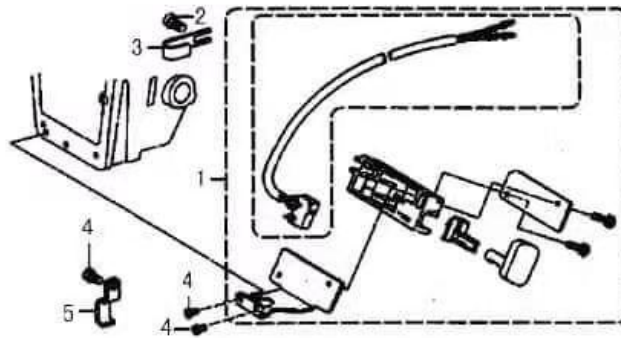

8、自动倒缝装置/AUTOMATIC REVERSE MECHANISM					
序号	物料编码	零件名称	Name of parts	数量	备注
1	113959001	自动倒缝开关组件	Automatically switch back seam component	1	
2	T60300612	螺钉M3×6	Screw, M3X6	1	
3	405029	电线夹	Wire clip	1	
4	T62670612	挡板螺钉SM3.57×40-6	Screw, SM3.57X40-6	3	
5	405028	电线压板U2	Wire plate U2	1	
6	151079001	自动倒缝连杆	Automatically link back seam	1	
7	151115001	自动倒缝连杆螺钉M628	Screw, M6	1	
8	T48050342	卡簧	C-type stop ring	1	
9	T21060212	螺母M6	Nut SM4.76X28	1	
10	151081001	自动倒送料曲柄	Automatic reverse feed crank	1	
11	T21760312	螺母SM4.37×40	Nut SM4.37X40	1	
12	151116001	倒缝铁芯连杆螺钉SM4.37×40	Screw, SM4.37X40	1	
13	151082001	倒缝电磁铁组件	Reverse stitching magnetic plug assy	1	
14	T62761012	螺钉SM5.95×28-10	Screw, SM5.95X28-10	2	

## 9、夹线装置/WIRE CLAMPING DEVICE

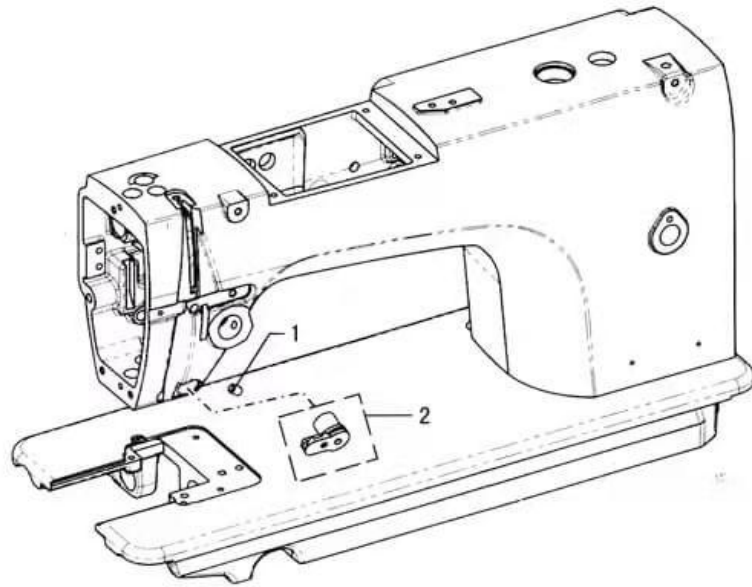

## 10、抬压脚电磁铁/PRESSER FOOT DEVICE

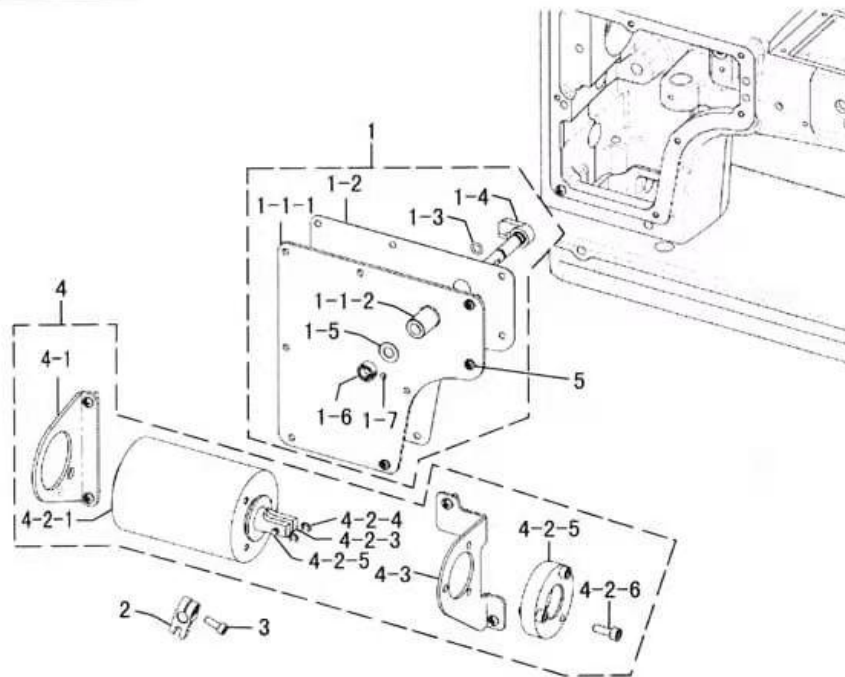

9、夹线装置/WIRE CLAMPING DEVICE					
序号	物料编码	零件名称	Name of parts	数量	备注
1	151340001	电子夹线器组件	Sweep line solenoid assembly	1	
2	T13760612	螺钉SM5.95×28-6	Screw SM5.95X28-6	1	

10、抬压脚电磁铁/PRESSER FOOT DEVICE					
序号	物料编码	零件名称	Name of parts	数量	备注
1	*	后盖板总组件	Rear plate assy	1	自配件
1-1	151261001	后盖板组件	Rear plate assy	1	
1-1-1	151194001	后盖板	Side plate	1	
1-1-2	151256001	后盖板连接柱		1	
1-2	151195001	后盖板垫片	Gasket for arm side cover	1	
1-3	T81007070	O型圈P7	O-ring P7	2	
1-4	119165	压脚提升轴	Knee lifter shaft	1	
1-5	108055	平垫圈	Washer, 11ain	1	
1-6	119163	压脚提升轴紧圈	Knee lifter shaft Set collar	1	
1-7	T14680432	螺钉SM4.37×40-4	Screw SM4.37X40-4	2	
2	119187	电磁抬压提升曲柄	Presser foot lifter arm	1	
3	T18711432	螺钉SM4.76×40-14	Screw SM4.76X40-14	1	
4	*	抬压脚电磁铁总组件		1	自配件
4-1	151250001	电磁铁架L	Solenoid base L	1	
4-2	113961001-1	抬压脚电磁铁组件	P-foot solenoid assy	1	
4-2-1	113961001-1-1	抬压脚电磁铁	P-foot solenoid	1	
4-2-2	113961001-1-2	电磁铁连接销	Pin	1	
4-2-3	113961001-1-3	电磁铁芯		1	
4-2-4	T48040342	挡圈E4	Ring E4	2	
4-2-5	113961001-1-4	电磁铁盖	Solenoid stopper	1	
4-2-6	13961001-1-6	螺钉	Screw		
4-3	151251001	电磁铁架R	Solenoid base R	1	
5	T62501216	螺钉M5×12	Screw M5X12	7	
6	113961001-1-7	抬压电磁铁罩壳	Cover	1	
7	113961001-1-8	螺钉SM3.57×40-5	Screw SM3.57X40-5	1	

## 11、润滑装置/OIL LUBRICATION MECHANISM

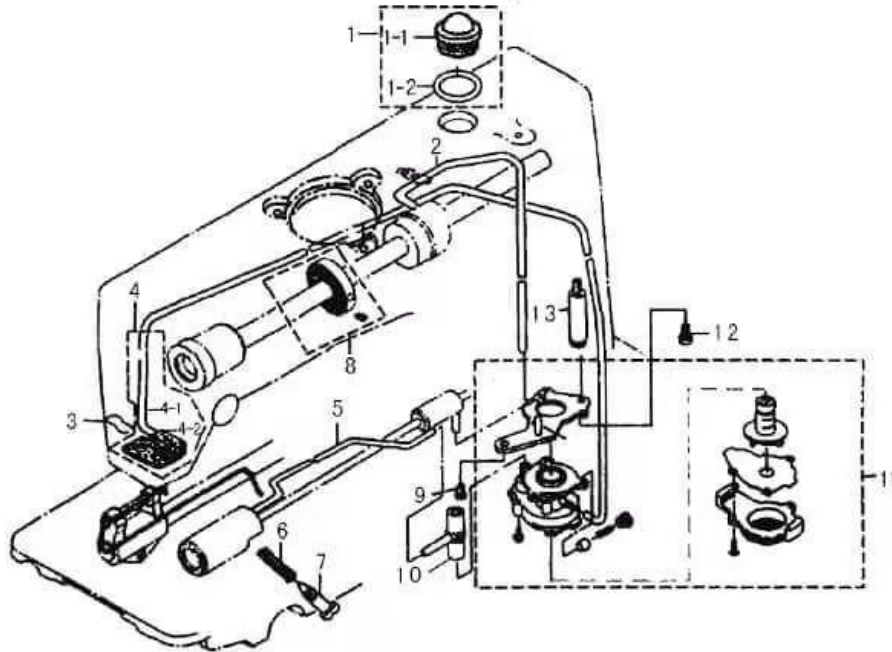

## 12、油盘装置/OIL RESERVOIR MECHANISM

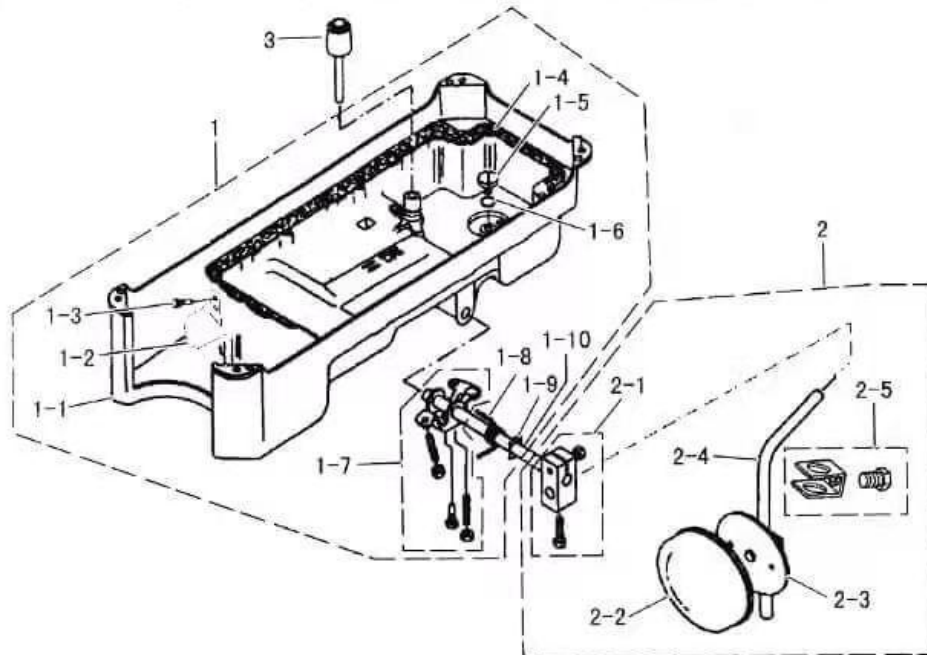

11、润滑装置/OIL LUBRICATION MECHANISM					
序号	物料编码	零件名称	Name of parts	数量	备注
1	108486	油窗组件	Oil cap assy	1	自配件
1-1	108165	油窗	Oil cap	1	
1-2	108166	O型圈	O-ring, PW14	1	
2	151136001	上轴供油管	On the shaft for the pipeline	1	
3	151105001	滤油毡压簧	Filter felt compression spring	1	
4	108497	回油管组件	Oil return pipe assy	1	自配件
4-1	100630700	回油管	Oil return pipe	1	
4-2	777027001	机头回油滤油毡	Felt pouch	1	
5	151135001	旋梭供油管	Hook for tubing	1	
6	108175	调节弹簧	Adjusting spring	1	
7	108174	调节螺钉SM4. 37×40-19	Screw, SM4. 37X40-19	1	
8	151151000	绕线器驱动轮组件	Winder wheel assembly	1	自配件
8-1	122011001	绕线器驱动轮	Winder wheel	1	
8-2	T14060832	螺钉M6×8	<del>M6×8</del>	2	
9	T62760612	油泵螺钉SM5. 95×28-6	Screw, SM5. 95X28-6	3	
10	151138001	供油管接头	For pipe joints	1	
11	151120001	油泵组件	Pump components	1	
12	121508001	油泵连接螺柱螺钉	Stud screw pump connection	1	
13	151137001	油泵连接螺柱	Pump connection stud	1	

12、油盘装置/OIL RESERVOIR MECHANISM					
序号	物料编码	零件名称	Name of parts	数量	备注
1	777023000	油盘组件	Oil reservoir assy	1	自配件
1-1	777023001	油盘	Oil reservoir	1	
1-2	777024001	油盘导油板	Oil reservoir stopper plate	1	
1-3	101018	螺钉SM4. 37×40	Screw SM4. 37X40	1	
1-4	151032001	油盘垫	Gasket for oil reservoir	1	
1-5	151078001	排油孔螺钉SM7. 94×24-7	Screw, SM7. 94X24-7	1	
1-6	101197	排油孔螺钉O型圈	O ring	1	
1-7	151067001	膝控限位架组件	knee lifter stop bracket assy	1	
1-8	151068001	膝控复位簧	twist spring	1	
1-9	108198-8	膝控复铰链轴挡圈	retaining ring e10	1	
1-10	151069001	膝控铰链轴	Knee lifter shaft	1	
2	*	磁块垫组件	knee lifter plate assy	1	自配件
2-1	108198-1	磁块弯杆接头组件	joint for knee lifter bell crank assy	1	
2-2	1101280	磁块垫	knee lifter plate	1	
2-3	108198-4	膝控磁块	knee lifter plate assy	1	
2-4	108198-3	膝控弯杆	knee lifter bar	1	
2-5	108198-5	磁块架组件	bracket far knee lifter plate	1	
3	100411001	顶杆	Mandrel	1	

### 13、附件/ACCESSORIES

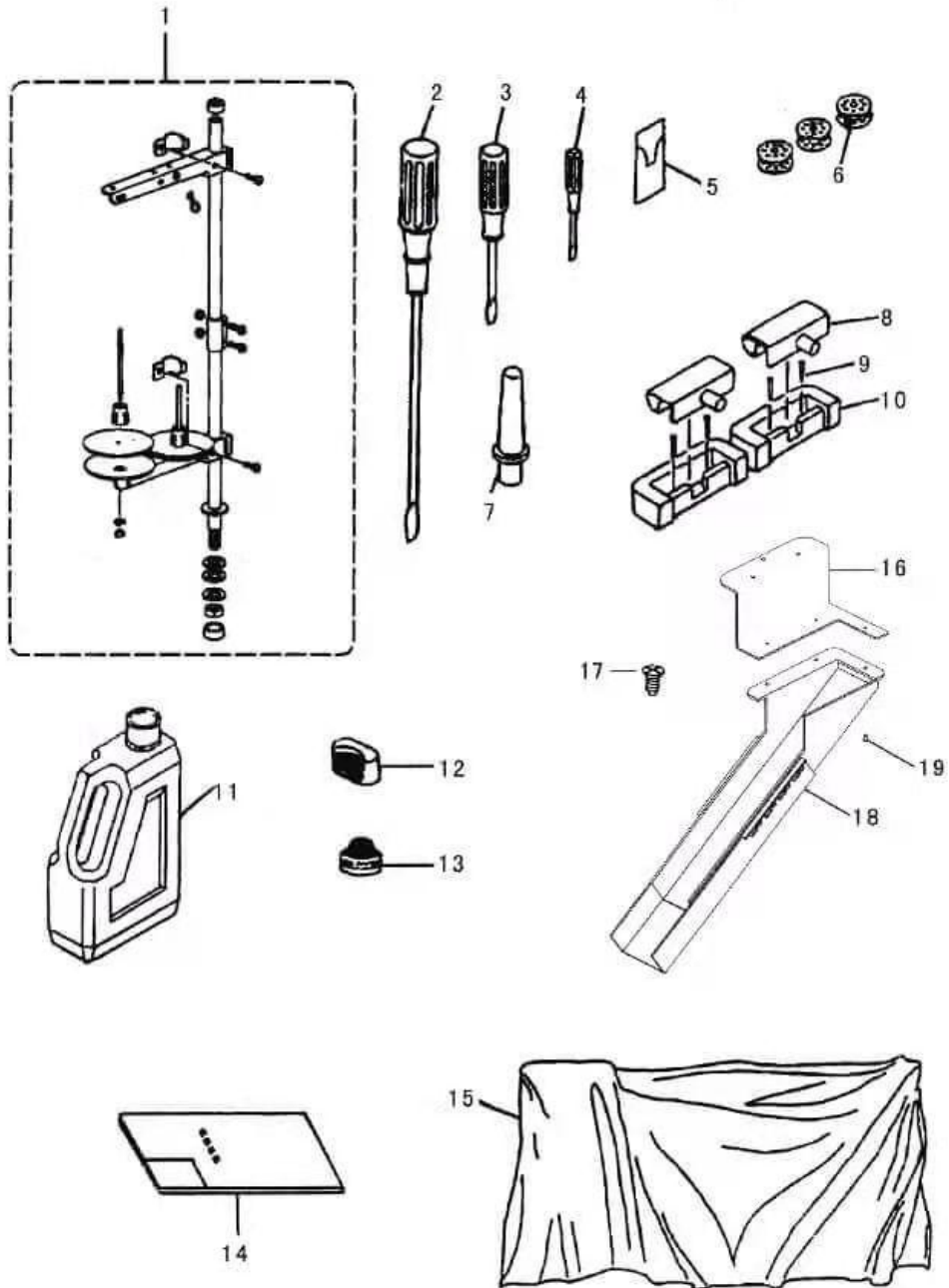



高林股份有限公司  
KAULIN MFG. CO., LTD.

由於對產品的改良及更新，本產品使用說明書中與零件圖之產品及外觀的修改恕不事先通知！  
The specification and/or appearances of the equipment described in this instruction book & parts list are subject to change because of modification which will without previous notice.  
DL8000-RM1.JUL.2025