

# SIRUBA

電控參數說明書

ELECTRONIC CONTROL PARAMETER MANUAL

■ BT430Q/438Q/530Q/630Q



---

## 前 言





歡迎您使用本公司的特種縫紉機控制系統。

請您仔細閱讀本操作手冊，以確保正確的操作、使用特種縫紉機，請按照本手冊內注明的方式進行操作，否則，如違規操作所造成損失本公司不承擔責任。此外，請將本用戶手冊妥善保存在安全地點，以便隨時查閱。若發生故障須由本公司指定的技術人員或專業人員進行維修。

# 安全注意事項

## 1. 安全操作的標誌及含義

本使用說明書及產品所使用的安全標誌是為了讓您正確安全的使用產品，防止您及其他人受到傷害。標誌的圖案和含義如下：

	危險	如果忽視此標記而進行錯誤的操作，會導致人員的重傷或死亡。
	注意	如果忽視此標記而進行錯誤的操作，會導致人員的受傷和設備的損壞。
		該符號表示“應注意事項”。三角中的圖案表示必須要注意的內容。(例如左邊的圖案表示：“當心受傷”)
		該符號表示“禁止”
		該符號表示“必須”。圓圈中的圖案表示必須要做的內容。(例如左邊的圖案表示“必須接地”)

## 2. 安全注意事項

 危險	
	打開控制箱時，先關閉電源開關並將電源插頭從插座上拔下後，等待至少 5 分鐘後，再打開控制箱蓋。觸摸帶有高電壓的區域會造成人員受傷。
 注意	
使用環境	
	應避免在強電氣干擾源（如高頻焊機）的附近使用本縫紉機。 強電氣干擾源可能會影響縫紉機的正常操作。
	電源電壓的波動應該在額定電壓的±20%以內的環境下使用。 電壓大幅度的波動會影響縫紉機的正常操作，需配備穩壓器。
	環境溫度應在 5°C~35°C的範圍內使用。 低溫或高溫會影響縫紉機的正常操作。
	相對濕度應在 45%~85%的範圍內，並且設備內不會形成結露的環境下使用。 乾燥、潮濕或結露的環境會影響縫紉機的正常操作。
	壓縮空氣的供氣量應大於縫紉機所要求的總耗氣量。壓縮空氣的供氣量不足會導致縫紉機的動作不正常。
	萬一發生雷電暴風雨時，關閉電源開關，並將電源插頭從插座上拔下。雷電可能會影響縫紉機的正常操作。
安裝	
	請讓受過培訓的技術人員來安裝縫紉機。
	安裝完成前，請不要連接電源。 如果誤按啟動開關，縫紉機動作會導致受傷。

	縫紉機頭倒下或豎起時，請用雙手操作。不要用力壓縫紉機。 如縫紉機失去平衡，縫紉機滑落到地上會造成受傷或機器損壞。
	必須接地。 接駁地線不牢固，是造成觸電或誤動作的原因。
	所有電纜應固定在離活動部件至少 25mm 以外處。另外，不要過度彎曲或用卡釘固定得過緊。會引起火災或觸電的危險。
	請在機頭上安裝安全罩殼。
<b>縫紉</b>	
	本縫紉機僅限於接受過安全操作培訓的人員使用。
	本縫紉機不能用於除縫紉外的任何用途。
	使用縫紉機時必須戴上保護眼鏡。 如果不戴保護眼鏡，斷針時機針折斷部分可能會彈入眼睛造成傷害。
	發生下列情況時，請立即切斷電源。否則誤按下啟動開關時，會導致受傷。 1.機針穿線時      2.更換機針時      3.縫紉機不使用或人離開縫紉機時
	縫紉過程中，不要觸摸任何運動部件或將物件靠在運動部件上，因為這會導致人員受傷或縫紉機損壞。
	如果縫紉機操作中發生誤動作，或聽到異常的雜訊或聞到異常的氣味，應立即切斷電源。然後請與購買商店或受過培訓的技術人員聯繫。
	如果縫紉機出現故障，請與購買商店或受過培訓的技術人員聯繫。
<b>維護和檢查</b>	
	只有經過訓練的技術人員才能進行縫紉機的維修、保養和檢查。
	與電氣有關的維修、保養和檢查請及時與電控廠家的專業人員進行聯繫。
	發生下列情況時，請關閉電源並拔下電源插頭。否則誤按啟動開關時，會導致受傷。 1.檢查、調整和維修      2.更換彎針、切刀等易損零部件
	在檢查、調整和修理任何使用氣動設備之前，請先斷開氣源，並等壓力錶指針下降到“0”為止。
	在必須接上電源開關和氣源開關進行調整時，務必十分小心遵守所有的安全注意事項。
	未經授權而對縫紉機進行改裝而引起的縫紉機損壞不在保修範圍內。

---

# 目錄

1 概要說明.....	1
概述.....	1
技術參數表.....	1
縫紉花樣列表(BT430Q).....	2
縫紉花樣列表(BT438Q).....	7
1.5 縫紉花樣列表(BT630Q).....	10
安全使用注意事項.....	14
使用上的預防措施.....	16
標準化.....	18
操作方式.....	18
2 操作說明.....	19
通用按鍵.....	19
基本操作.....	21
普通花樣操作.....	22
花樣登記.....	24
花樣命名.....	25
2.6 繞線.....	26
2.7 穿線.....	27
花樣選擇.....	28
縫紉數據設定.....	29
P 花樣登記.....	30
試縫操作.....	32
計數器操作.....	33
調整起縫點操作.....	36
2.14 急停.....	36
3 快捷 ( P ) 花樣操作.....	37
P 花樣資料登錄.....	37
P 花樣編輯.....	39
P 花樣複製.....	40
P 花樣縫製.....	41
4 組合 ( C ) 花樣操作.....	43
C 花樣資料登錄.....	43
C 花樣編輯.....	45
C 花樣選擇.....	47
C 花樣縫製.....	48
5 花樣圖案編輯.....	50
進入花樣編輯模式.....	50
花樣編輯.....	54
花樣的修改.....	58
退出花樣編輯模式.....	60
6 資訊功能.....	61
查看版本資訊.....	61

7 通訊功能.....	62
關於可以處理的資料.....	62
花樣傳輸.....	62
8 模式和參數設置.....	67
模式切換.....	67
三種模式：普通縫模式，花樣打版模式，迴圈縫模式。.....	67
普通縫模式.....	67
花樣打版模式.....	67
迴圈縫模式.....	67
8.2 測試.....	68
輸入測試.....	68
動作測試.....	69
輸出測試.....	69
外部輸出測試.....	70
主軸角度測試.....	70
模擬踏板校準.....	71
參數設置.....	72
基本設置 1.....	72
基本設置 2.....	77
高級設置.....	78
高級設置介面.....	78
高級設置參數.....	78
上位機升級.....	79
下位機升級.....	79
恢復出廠設置.....	79
原點調整.....	79
超級設置.....	80
超級設置介面.....	81
超級設置參數.....	81
分期付款設置.....	81
協助工具.....	82
範本 ID.....	82
更改啟動圖片.....	82
內核升級.....	82
提示音升級.....	82
計數器.....	83
8.6 關於.....	83
9 附錄 1 誤碼表.....	84

# 1 概要說明

## 概述

本系列工業縫紉機電腦控制系統，主軸電機採用具有世界先進水準的交流伺服控制技術驅動，具有力矩大、效率高、車速穩定和噪音低等特點。操作面板設計多樣化可滿足不同客戶的配套要求；系統採用德國式結構設計，安裝和維修方便快捷，系統控制軟體可通過遠端通訊升級，方便使用者不斷提高產品性能。

## 技術參數表

	BT430Q直接驅動式電腦平縫打結機	BT438Q直接驅動式電腦平縫釘扣機
線跡形式	單針平縫	
最高縫紉速度	3,200 sti/min	2,700 sti/min
尺寸(X×Y)	最大 40×30 mm	最大 6.4×6.4 mm
縫紉鈕扣的尺寸	鈕扣外徑 8~30mm(※1)	
送布驅動方式	Y-θ 間歇送布(脈衝馬達驅動)	
針距	0.05~12.7mm	0.05~6.4mm
針數	請參閱「縫紉花樣列表」查看已輸入的縫紉花樣針數。	
最大針數	約 5,000 針(花樣 1)	
抬壓腳驅動方式	脈衝馬達驅動	
壓腳上升量 鈕扣夾 上升量	最大 17mm	最大 13mm
使用的旋梭	標準半轉旋梭(雙倍旋梭另售)	標準半轉旋梭
數碼式張力器	標準裝備	
掃線器	標準裝備	
切線裝置	標準裝備	
夾線裝置	規格: 選件	選件
資料存儲方式	快擦寫記憶體(使用 U 盤可以追加任意種縫紉花樣)	
資料記錄介質	U 盤(※2)	
迴圈程式數	最多可註冊 30 個(每個最多 50 個步驟)	
存儲資料數	已設置 89 種縫紉圖案 (最多 799 個附加縫紉花樣類型。追加總針數在 500,000 針以內。)(※3)	已設置 64 種縫紉圖案
馬達	AC 伺服馬達 750W	
重量	頭部:約 57kg, 操作盤:約 0.4kg 控制箱:9kg	
電源	單相 220V、3 相 380 V (對於三相 380 V, 需要使用變壓器。) 2502B 2278B	

※1 外徑 20mm 以上時，請使用選購件鈕扣夾元件 B(S03634-101)。

※2 不保證使用任何介質帶來的操作問題。

※3 可記錄的縫紉花樣的數量和針數將視每個縫紉花樣的針數而定。

## 縫紉花樣列表(BT430Q)

下面所示的縫紉花樣已預先設置好，可以根據規格予以選擇使用。(只要能夠確認是在壓腳、送布板的工作範圍內，就可以選擇使用任一種縫紉花樣。)

請使用符合各種縫紉花樣要求的壓腳和送布板。

縫紉尺寸為 100%縮放率時的長度。

适用于一般重量的布料 (-03)									
号码	花样	针数	尺寸 (mm)		号码	花样	针数	尺寸 (mm)	
			长度	宽度				长度	宽度
1		42	16	2	65		43	16	2
4		31	16	2	66		32	16	2
5		29	10	2	67		30	10	2
8		21	7	2	68		22	7	2
13		35	10	2	69		36	10	2
15		42	10	2	70		43	10	2
20		28	7	2	71		29	7	2
21		35	7	2	72		36	7	2
64		30	16	2	89		90	24	3
适用于厚重的布料 (-05)									
号码	花样	针数	尺寸 (mm)		号码	花样	针数	尺寸 (mm)	
			长度	宽度				长度	宽度
2		42	20	3	18		56	24	3
3		35	20	3	19		64	24	3
6		30	16	3	62		42	20	3
14		35	16	3	63		35	20	3
16		43	16	3	78		43	20	3
17		42	24	3	79		36	20	3
适用于厚重的布料 (-05)									









号码	花样	针数	尺寸 (mm)		号码	花样	针数	尺寸 (mm)	
			长度	宽度				长度	宽度
80		31	16	3	83		43	24	3
81		36	16	3	84		57	24	3
82		44	16	3	85		65	24	3

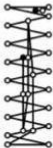

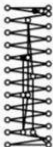

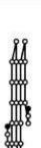
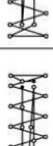
适用于针织布料 (-OK) 和女性内衣 (-0F)

号码	花样	针数	尺寸 (mm)		号码	花样	针数	尺寸 (mm)	
			长度	宽度				长度	宽度
7		28	8	2	73		29	8	2
9		21	7	2	74		22	7	2
22		14	7	2	75		15	7	2
31*		28	8	2	76*		29	8	2
32*		22	8	2	77*		23	8	2
33*		15	8	2					





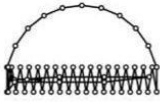

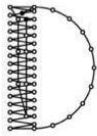

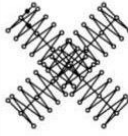
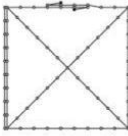
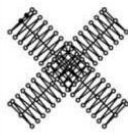
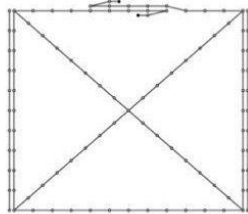

\* 始针和终结针的位置在图案的中间。

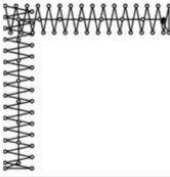
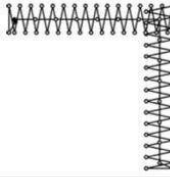
直线结					垂直曲折缝				
号码	花样	针数	尺寸 (mm)		号码	花样	针数	尺寸 (mm)	
			长度	宽度				长度	宽度
10		21	10	0.3	44		46	9	15
11		28	10	0.3					
12		28	20	0.3	45		70	9	25
23		35	25	0.3					
24		42	25	0.3					
25		45	25	0.3					

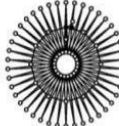
垂直结					垂直直线结				
号码	花样	针数	尺寸 (mm)		号码	花样	针数	尺寸 (mm)	
			长度	宽度				长度	宽度
26		28	3	10	28		19	0.3	10
27		35	3	10	29		21	0.3	10
40		32	3	16	30		28	0.3	10
41		36	3	16	46		27	0.3	20
42		44	3	20	47		44	0.3	25
43		68	3	24					

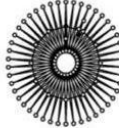
月牙结									
号码	花样	针数	尺寸 (mm)		号码	花样	针数	尺寸 (mm)	
			长度	宽度				长度	宽度
34		35	12	7	37		57	7	12
35		58	12	7	38		53	7	10
36		57	7	12	39		53	7	10

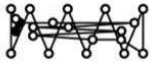
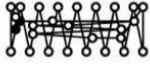
X形结					交叉结				
号码	花样	针数	尺寸 (mm)		号码	花样	针数	尺寸 (mm)	
			长度	宽度				长度	宽度
48		70	10	10	50		84	16	16
49		93	9.6	9.6	51		105	30	26

L形结									
号码	花样	针数	尺寸 (mm)		号码	花样	针数	尺寸 (mm)	
			长度	宽度				长度	宽度
52		60	11.3	11.2	53		60	11.3	11.2
54		78	15.3	15.2	55		78	15.3	15.2
菊形缝									
号码	花样	针数	尺寸 (mm)		号码	花样	针数	尺寸 (mm)	
			长度	宽度				长度	宽度
56		106	9	9	59		104	10	10
57		116	9	9	60		114	10	10
58		127	9	9	61		124	10	10
圆眼钮孔									
号码	花样	针数	尺寸 (mm)						
			长度	宽度					
86		21	6	2					
87		28	6	2					
88		35	6	2					





如果想缝纫标准花样以外的其他缝纫花样，可以使用 PS-300B 创建原始花样。详情请咨询当地的兄弟销售办事处。

**创建附加缝纫花样时请注意**

如果反复缝纫（短循环运转）运针数（15 针以下）短的缝纫数据，则可能会引起上轴马达过热错误 [E150] 的现象。

## 縫紉花樣列表(BT438Q)

下麵所示的縫紉花樣已預先設置好。只要針可以穿過鈕孔，就可以選擇任何縫紉花樣。對於沒有包縫線的縫紉花樣，在完成一邊縫紉後就進行剪線，然後再進行另一邊的縫紉。

号码	组孔数	花样	线数	包缝数	针数	尺寸 (mm)				
						X	Y			
1	2		6	—	12	3.4	0			
※1 54			6	—	12					
2			8	—	14					
※1 55			8	—	14					
3			10	—	16					
4			12	—	18					
※2 5			16	—	22					
※2 6			20	—	26					
※1 56				6	—			11	0	3.4
※3 7				6	—			12		
※3 23	10	—		16						
※3 8	12	—		18						
※3 9	3		5-5-5	—	21	2.6	2.4			
※3 24			7-7-7	—	27					
※3 25			5-5-5	—	21					
※3 26			7-7-7	—	27					
※1 57	4		6-6	1	18	3.4	3.4			
10			6-6	1	19					
※1 58			8-8	1	22					
11			8-8	1	23					
12			8-8	3	25					
13			10-10	1	27					
27			12-12	1	31					

※1 用于小孔纽扣。

※2 使用程序前，请检查组孔直径不小于 2mm。

※3 不可使用钮扣抬起弹簧。

号码	组孔数	花样	线数	包缝数	针数	尺寸 (mm)	
						X	Y
14 ※4	4		6-6	0	24	3.4	3.4
36 ※5			6-6	0	24		
28 ※4			8-8	0	28		
37 ※5			8-8	0	28		
15 ※4			10-10	0	32		
38 ※5			10-10	0	32		
29 ※4			12-12	0	36		
39 ※5			12-12	0	36		
59 ※1			6-5	1	17		
16			6-5	1	18		
60 ※1			8-7	1	21		
17			8-7	1	22		
30			10-9	1	26		
61 ※1			6-6	1	18		
18			6-6	1	19		
62 ※1			8-8	1	22		
19			8-8	1	23		
63 ※1			10-10	1	26		
31			10-10	1	27		
45			12-12	1	31		
20 ※4			6-6	0	24		
40 ※5			6-6	0	24		
32 ※4			8-8	0	28		
41 ※5			8-8	0	28		
33 ※4	10-10		0	32			
42 ※5	10-10		0	32			

※1 用于小孔纽扣。

※4 在完成一边缝纫后，钮扣夹就上升并进行拔线动作。为了将缝纫进行到底，在另一边的缝纫开始之前，请继续踩下脚踏开关；或在完成一边缝纫后，请再次踩下脚踏开关。

※5 在完成一边缝纫后，钮扣夹不上升而只进行拔线动作，并继续进行另一边的缝纫。

号码	组孔数	花样	线数	包缝数	针数	尺寸 (mm)	
						X	Y
※1 64	4		6-6	1	18	3.4	3.4
※3 21			6-6	1	19		
※3 34			10-10	1	27		
※3※4 22			6-6	0	24	2.4	
※3※5 43			6-6	0	24		
※3※4 35			10-10	0	32		
※3※5 44			10-10	0	32		
46			6-7	1	19	3.4	3.4
47			8-9	1	23		
48			10-11	1	27		
49			12-13	1	31		

※1 用于小孔纽扣。

※3 不可使用纽扣抬起弹簧。

※4 在完成一边缝制后，纽扣夹就上升并进行拔线动作。为了将缝制进行到底，在另一边的缝制开始之前，请继续踩下脚踏开关；或在完成一边缝制后，请再次踩下脚踏开关。

※5 在完成一边缝制后，纽扣夹不上升而只进行拔线动作，并继续进行另一边的缝制。

用于带柄纽扣					
号码	花样	线数	针数	尺寸 (mm)	
				X	Y
50		6	12	3.4	0
51		8	14		
52		10	16		
53		12	18		

**创建附加缝制花样时请注意**

如果反复缝制（短循环运转）运针数（15 针以下）短的缝制数据，则可能会引起上轴马达过热错误 [E150] 的现象。











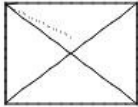
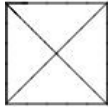
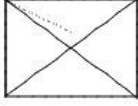

### 縫紉花樣列表(BT630Q)

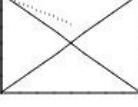

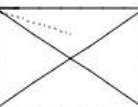
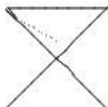

下面所示的縫紉花樣已預先設置好，可以根據規格予以選擇使用。(只要能夠確認是在壓腳、送布板的工作範圍內，就可以選擇使用任一種縫紉花樣。)

請使用符合各種縫紉花樣要求的壓腳和送布板。

縫紉尺寸為 100%縮放率時的長度。

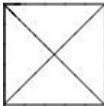
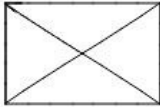
No.	落針圖	針數	縫紉尺寸 mm		No.	落針圖	針數	縫紉尺寸 Mm	
			縱	橫				縱	橫
1		54	30	40	9		38	20	20
2		46	30	30	10		38	20	20
3		113	20.1	38.4	11		33	18	18
4		97	20	28.8	12		33	18	18
5		81	20	19	13		30	18	18
6		52	11	9.4	14		30	13	18
7		48	25	25	15		39	25	35

8		48	25	25	16		108	30	40
No	落針圖	針數	縫紉尺寸 mm		No.	落針圖	針數	縫紉尺寸 mm	
			縱	橫				縱	橫
17		96	30	40	25		52	20	20
18		84	30	40	26		42	30	40
19		66	25	35.1	27		38	25	35
20		62	25	30	28		36	25	30
21		56	20	30	29		46	28	28
22		68	28	28	30		36	20	25
23		66	20	28	31		36	20	25

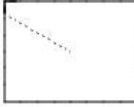
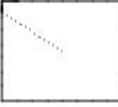
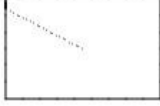
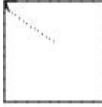
24		62	20	25	32		50	15	15
No.	落針圖	針數	縫紉尺寸 mm		No.	落針圖	針數	縫紉尺寸 mm	
			縱	橫				縱	橫
33		56	16	25	41		48	20	40
34		65	30	35	42		33	27. 2	37.1
35		30	15	15					
36		34	18	24					
37		36	20	24					
38		36	16	25					
39		42	25	25					

40		42	25	35					
----	---	----	----	----	--	--	--	--	--

	机 型	BT630Q 小型花樣縫紉機
1	線跡形式	單針平縫
2	最高縫紉速度	2,700rpm
3	縫紉尺寸 (X×Y)	最大：80×60mm;
4	送布驅動方式	間歇送布 (脈衝馬達驅動)
5	針距	0.05-12.7mm
6	針數	記憶體 500,000 針 (※)
7	最大針數	20,000 針 (1 個程式)
8	存儲可能縫紉的數據	記憶體：999 (※) .U 盤：無限制
9	抬壓腳驅動方式	電磁規格：脈衝馬達驅動，空壓規格：空壓式
10	壓腳上升量	電磁規格：最大 17mm，空壓規格：最大 17mm
11	2 段壓腳	左右一體式壓腳
12	間歇壓腳上升量	22mm
13	間歇壓腳行程	2-4.5mm、4.5-10mm 或 0 (出廠時 3mm)
14	使用的旋梭	半回轉 2 倍旋梭 (標準旋梭另買)
15	扣線裝置	標準裝備
16	切線裝置	標準裝備
17	資料存儲方式	記憶體 (快擦寫記憶體)，U 盤
18	使用者程式數	50
19	迴圈程式數	9
20	馬達	AC 伺服馬達 550W
21	重量	頭部：約 88kg，操作盤：約 0.6kg 控制箱：14.2-16.2kg (根據電壓不同而不同)
22	電源	單相 100V/220V、3 相 200V/220V/380V/400V 400VA
23	空氣壓力	0.5Mpa 1.81/min

最高縫製速度請根據縫製條件降低速度使用

---

## 安全使用注意事項

### ● 作業環境

本控制裝置請不要在下述的環境使用：

- 電源電壓
  - ◆ 電壓的變動會超出定格電壓±10%以上的場所。
  - ◆ 電源容量無法確保在規定容量的場所。
- 電波干擾
  - ◆ 旁邊有會發射出強烈電波和磁場的電波發射器和高周波機器的場所。
- 溫濕度
  - ◆ 室溫在0°C~50°C之間的場所。
  - ◆ 室外或日光會直接照射到的場所。
  - ◆ 暖爐（電熱器）旁的場所。
  - ◆ 相對濕度在5%~95%（不凝露）之間的場所。
- 空氣
  - ◆ 具有腐蝕性或多灰塵的場所。
  - ◆ 容易發生氣爆或油爆的場所。
- 振動
  - ◆ 縫紉機放置的場所容易發生過度振動的話，把控制箱放置到別的地方。

### ● 安裝

- 控制箱
  - ◆ 請遵照說明正確裝好
- 附件
  - ◆ 如要安裝其它附件時，請先關掉電源並拔掉電源插頭。
- 電源線
  - ◆ 請不要用重力去壓住電源線或過度的扭曲電源線。
  - ◆ 請不要將電源線靠近轉動的部位，最少要離開 25mm 以上。
  - ◆ 控制箱要接入電源前，請必再查看要接入的電源電壓是否與控制箱上標示的電壓相同及確定位置後，才可供應電源。如有接用電源變壓裝置的話，同樣的要檢查一下後才可供應電源。這時縫紉機上的按鈕式電源開關一定要放在 [OFF]。
- 接地
  - ◆ 為防止雜訊干擾及漏電而發生電擊事件，電源線上的接地線定要確實做好接地。
- 附屬裝置
  - ◆ 如要接用電氣方面的附屬裝置的話，請遵照指示的位置接好。
- 拆卸
  - ◆ 要卸下控制箱時，必須要先關掉電源並拔掉電源插頭。
  - ◆ 在拔離電源插頭時不可只拉電源線，必須用手拿住電源插頭拔出。
  - ◆ 控制箱裡面有危險的高壓電，所以要打開控制箱蓋的話，需要先關掉電源後等候5分鐘以上才可打開控制箱蓋。

- **保養、檢查和修理**

- 修理和保養的作業，要請經過訓練的技術人員執行。
- 更換機針和梭子時，請務必要關電。
- 請使用正廠的零件。

- **其它的安全對策**

- 縫紉機運轉中請不要去觸摸會轉動和會移動的部位（特別是機針和皮帶附件）等，並注意頭髮不要靠近它們，以免發生危險。
- 控制裝置不可摔落地，更不可在空隙間塞入其它物品。
- 請不要在拆掉各護蓋的情形下運作。
- 如本控制裝置有損傷或無法正常運作時，必要請有經驗的技術人員調整，或檢查修理，在故障還沒排除前請不要再去運轉它。
- 敬請各客戶們不要自行改造或變更本控制裝置。

- **廢棄處理**

- 請以一般產業廢棄物處理。

- **警告示意和危險示意**

- 錯誤的行為可能會發生危險，其程度如後述的標示區別說明。





 <b>警告</b>	错误的行动可能会发生重伤或死亡。	 <b>注意</b>	错误的行动可能会发生伤害或房屋或财产的损害。
---	------------------	---	------------------------

- 標示符號的表示如下說明。

	请遵照指示内容作业。		注意高压电（电击）的危险。
	注意高温。		务必接上接地线。
	绝对不要执行。		

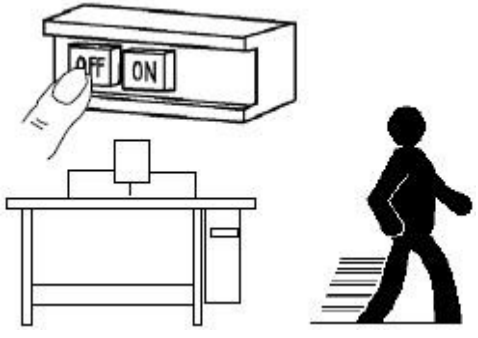
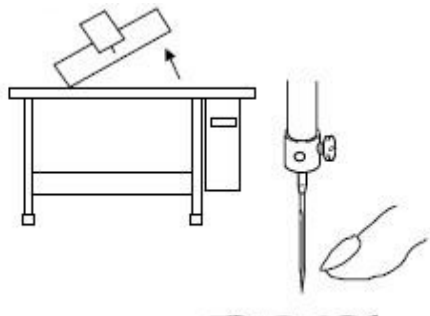
## 使用上的預防措施

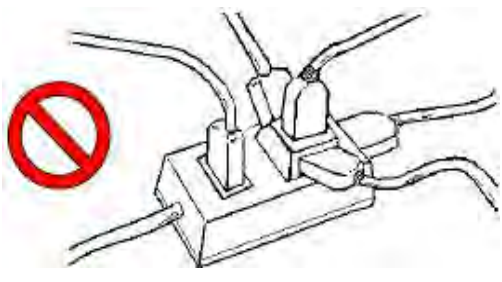

<p>1、當手要按開關 [ON] 時，腳定要離開腳踏板。</p> 	<p>2、要離開工作崗位時，請務必關掉電源。</p> 
<p>3、如要橫倒頭部或更換機針或穿麵線時，請務必要關掉電源。</p> 	<p>4、接地線要做好接地。</p> 
<p>5、不要用家庭用多插孔式延長線。</p> 	<p>6、控制箱內部存有危險的高壓電，所以關掉電源後等候 5 分鐘才可打開控制箱蓋。</p> 
<p>7、更換電機後，請務必參照本資料所示設置主軸電機安裝角度。</p>	<p>8、請遠離會產生高周波雜訊干擾的機器。</p>
<p>9、如利用外接信號插座接應用附屬裝置時，其連接線長度請儘量越短越好，長線可能會導致誤動作，連接線請用隔離線纜。</p>	

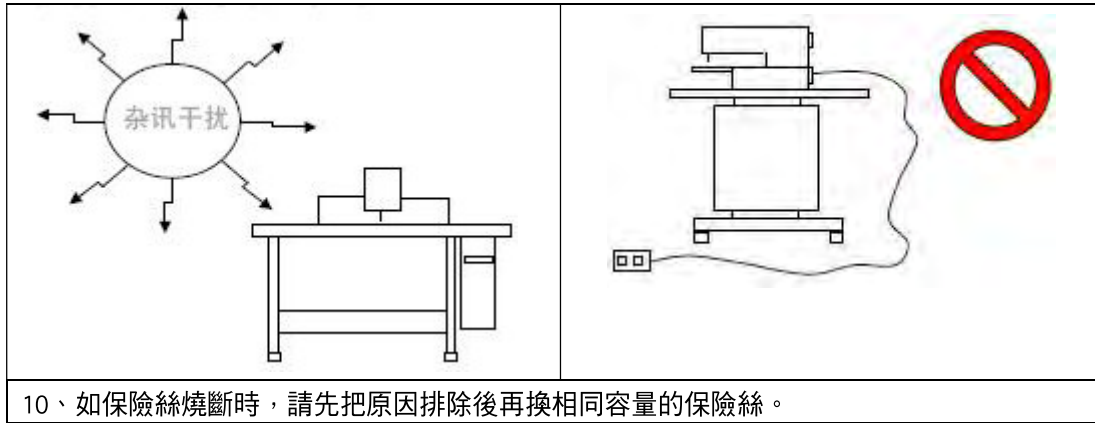

## 標準化

功能按鍵採用業界公認的圖形標識，圖形是國際化語言，各國使用者都可以識別。



## 操作方式

本系統觸控式螢幕操作面板採用了業界先進的觸摸操作技術，友好的介面以及便捷的操控都給用戶的日常使用帶來革新性的變化。使用者可以使用手指或者其他物體點觸螢幕，完成相應的操作。用戶在使用過程中應該注意避免使用尖銳的物體觸碰螢幕，以免對觸控式螢幕造成永久性損傷。

功能鍵包括準備鍵，資訊鍵，模式鍵以及通信鍵等。具體操作方法參照後面章節的說明。



用戶在使用過程中應該注意避免使用尖銳的物體觸碰螢幕，以免對觸控式螢幕造成永久性損傷。

## 2 操作說明

### 通用按鍵

在本系統的各介面上進行通用操作的按鍵如下：

序號	圖示	功能
1		確認鍵 → 輸入介面進入縫製介面/縫製介面退出至輸入介面
2		資訊鍵 → 查看版本資訊和穿線圖
3		通信鍵 → U 盤與面板通信，進行花樣或參數的相互拷貝
4		設置鍵 → 進入功能介面
5		花樣選擇鍵 → 打開花樣文件
6		登記鍵 → 登記花樣檔號碼
7		命名鍵 → 輸入花樣名
8		電動壓腳高度設置鍵 → 設置電動壓腳高度，氣動壓腳無效
9		中壓腳高度鍵 → 設置中壓腳高度
10		調整鍵 → 調整起縫點
11		穿線鍵 → 穿線
12		取消鍵 → 取消當前設定值/退出當前介面
13		確認鍵 → 保存當前設置值
14		試縫鍵 → 進入單步縫介面
15		繞線鍵 → 進入繞線狀態



## 基本操作

### ① 打開電源開關

打開電源之後，顯示出資料登錄介面。

### ② 選擇想縫製的圖案No.



當前介面下會顯示出已選擇的圖案No.，按下花樣選擇鍵

之後進入子功能表可以選擇圖案No.。

有關花樣選擇的操作，詳見【2.8 花樣選擇】一節。



### ③ 設定成可以縫製的狀態

按準備鍵之後，該按鈕顏色加深表示進入花樣確認介面，此時為可以縫製的狀態。

### ④ 開始縫製

把縫製品安放到壓腳部，踩踏板落下壓腳，縫紉機啟動，開始進行縫製。



## 普通花樣操作

### (1) 縫製資料登錄介面

資料登錄介面如右圖所示，詳細功能說明請見功能鍵說明表。

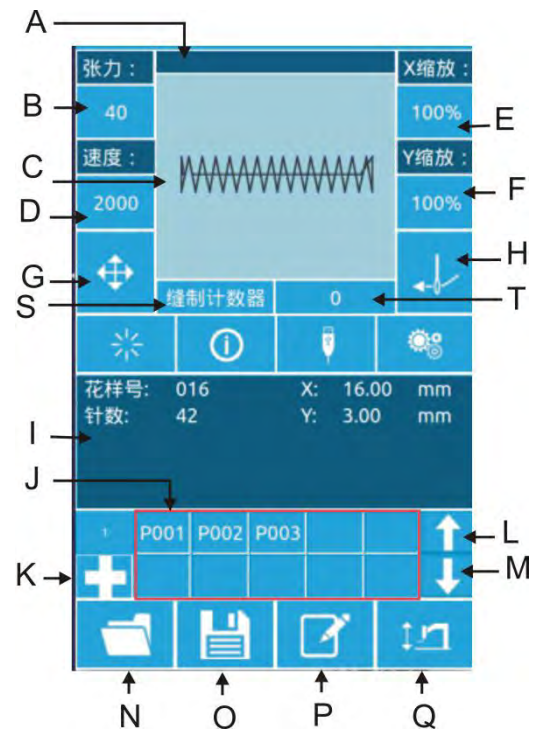

### 功能說明：

序號	功能
A	花樣名稱顯示區域
B	張力按鍵
C	花樣圖形顯示區域
D	速度按鍵
E	X 縮放率按鍵
F	Y 縮放率按鍵
G	調整起縫點按鍵
H	穿線按鍵
I	花樣資訊資訊顯示區域
J	P 花樣快捷按鍵區域
K	P 花樣登記按鍵
L	P 花樣上翻頁按鍵
M	P 花樣下翻頁按鍵
N	花樣選擇按鍵
O	花樣登記按鍵
P	花樣命名按鍵
Q	電動壓腳高度設置按鍵
S	計數器模式按鍵
T	計數值按鍵

(2) 縫製介面

按下  進入縫製介面如右圖所示。詳細功能說明請見功能鍵說明表。

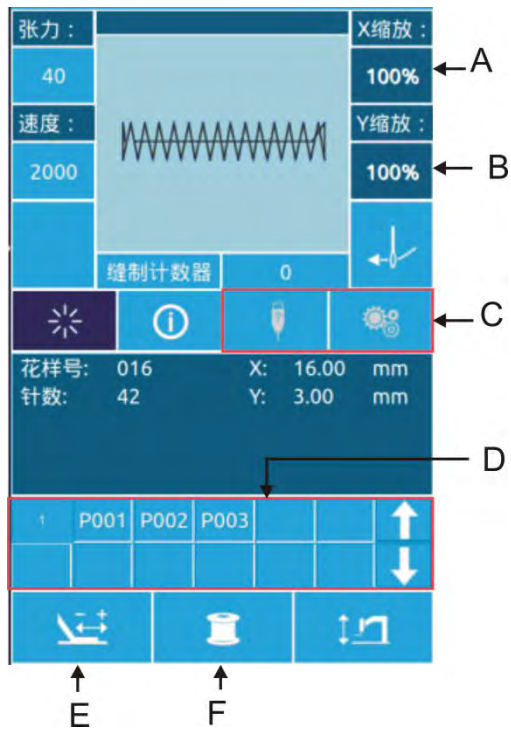

功能說明：

序號	功能
A	X 縮放率顯示
B	Y 縮放率顯示
C	不可操作按鍵
D	P 花樣區域不可操作
E	試縫按鍵
F	繞線按鍵
---	其他按鍵同輸入介面功能

## 花樣登記

最多可以登記普通花樣 999 個。按下  進入花樣登記介面（如右圖所示）：

### ① 輸入花樣號

通過數位鍵可以選擇想要輸入的花樣號碼，花樣號碼範圍必須為 201~999，如果輸入其他號碼會顯示超出號碼範圍。

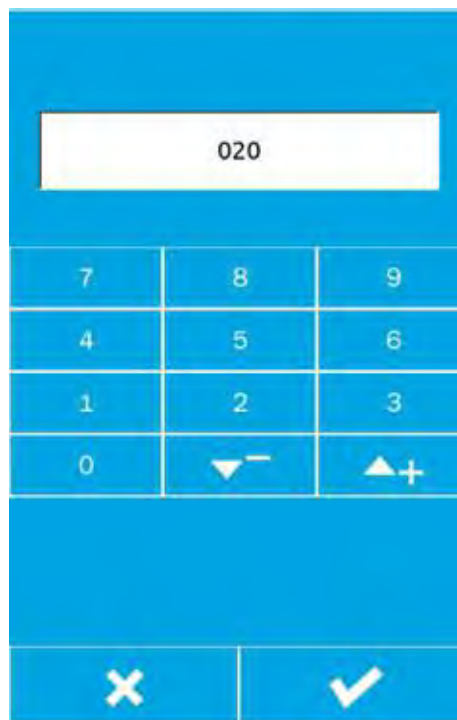

圖中顯示了一個花樣登記介面的數位鍵盤。鍵盤上方有一個輸入框，顯示數字 020。鍵盤包含數字 0 到 9，以及減號（-）和加號（+）符號。在鍵盤底部，有兩個按鈕，分別是取消（X）和確認（✓）。

### ② 登記新花樣

確定花樣號碼後按下 ，之前顯示花樣資料會複製到新登記花樣中，操作結束後返回到新登記花樣資料登錄介面。

如果輸入號碼已被登記號碼會提示是否覆蓋已存花樣。

按  按鍵後退出登記介面。

## 花樣命名

按下  進入花樣命名介面 (如右圖所示)。

A	刪除	逐個刪除輸入字元
B	右移	游標右移
C	左移	游標左移
D	清空	清空當前輸入的全部字元

選擇想要輸入的字元，按下  結束花樣命名操作。

通過移動游標可以確定該字元位置，刪除鍵可以消除該位置字元。

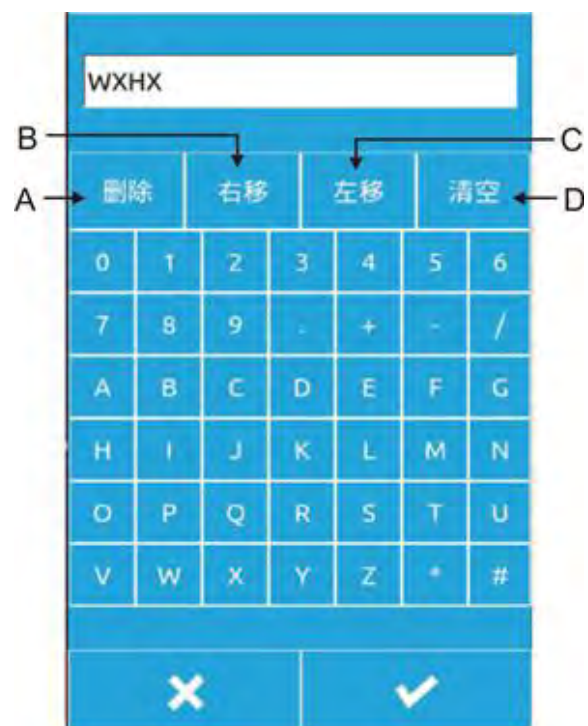

## 繞線

### ① 安裝梭芯

把梭芯插進繞線軸。如右圖所示。

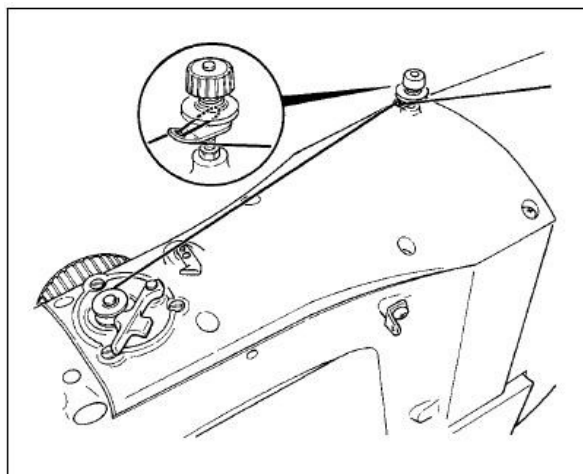

### ② 顯示底線繞線介面

在縫製介面上，按了繞線按鍵  之後，繞線介面被顯示出來（如右圖所示）。

### ③ 開始繞線

踩踏左踏板落壓腳後，踩踏啟動踏板開始繞線。

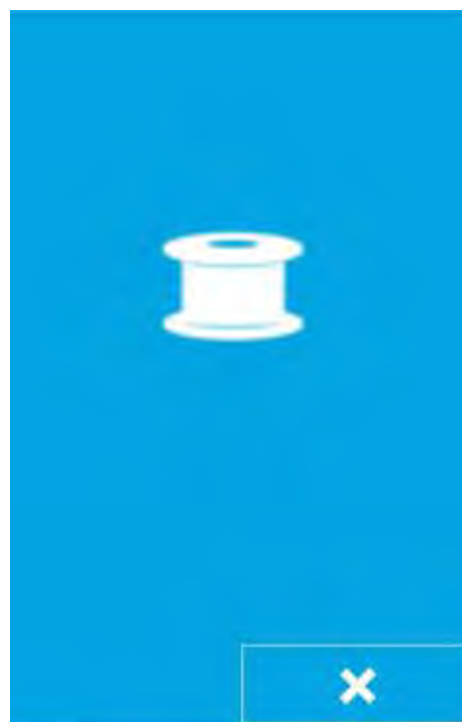

### ④ 停止縫紉機

繞線啟動後，再次踩踏啟動踏板則繞線停止轉動，繞線停止後踩踏左踏板壓腳抬起返回縫製模式。



## 穿線

### ① 進入穿線狀態

在輸入介面或縫製介面按  鍵進入穿線狀態，穿線按鍵變為紅色 ，畫面變化如圖所示，此狀態下機器無法進行其他操作。



### ② 退出穿線模式

穿線結束後，再次按下  鍵，返回到輸入介面或縫製介面。

## 花樣選擇

### ① 進入花樣選擇介面

資料登錄介面（如右圖 1 所示），點擊選擇按鍵 A 之後進入花樣選擇介面（圖 2）。

圖 2 資訊如下：

A	花樣名稱
B	花樣尺寸信息
C	花樣圖形顯示
D	已登記花樣號碼
	花樣上翻頁
	花樣下翻頁
	花樣刪除



圖 1

### ② 選擇花樣

花樣號碼區域D每頁可顯示25個花樣號碼；選中某個花樣號碼按鈕後，當前花樣圖形及資訊顯示在上方。花樣資訊包含花樣號碼、X方向長度、Y方向高度、花樣命名的字串（未命名的花樣不顯示字串）。

按下  完成花樣選擇操作。

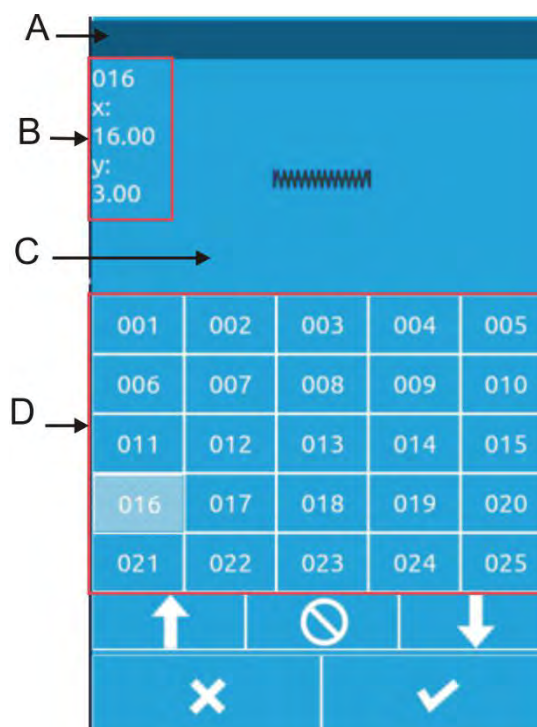

### ③ 花樣刪除

選中某個花樣號碼按鈕，按下  鍵就會刪除掉該花樣。

## 縫紉數據設定

### ① 進入縫紉資料設定介面

在資料登錄介面下相應按下 A、B、C 可分別進入縮放率設置和速度限制設置介面。

	項目	輸入範圍	初始值
A	張力值	0~120	40
B	縫製速度	400~2800rpm( 上限在超級設置參數中設置)	2000rpm
C	X 方向放大縮小率	1.0~200.0%	100.0%
D	Y 方向放大縮小率	1.0~200.0%	100.0%
E	壓腳高度	430Q:10~17mm	14mm
		438Q:6~13mm	10mm
		630Q: 10~17mm	14mm

注：最高速度限制的在“超級設置→參數設置→3:最大縫製速度”中限制。

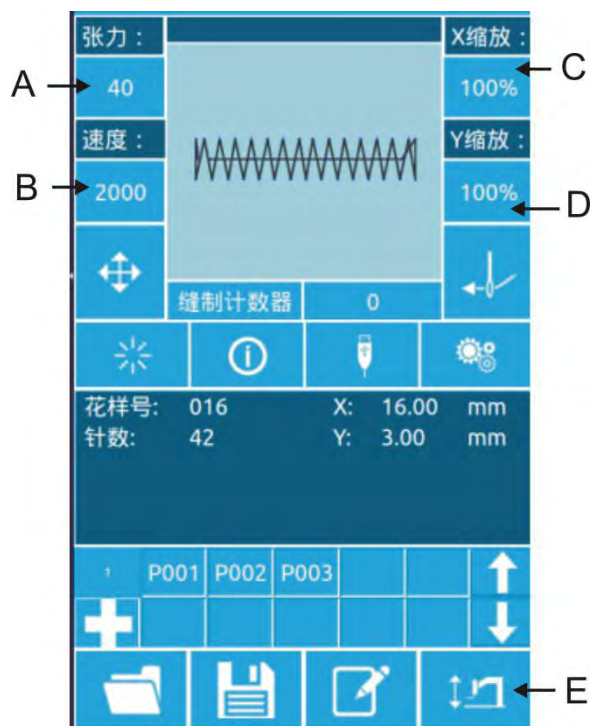

## ② 縮放率設定

右圖為放大縮小率設定介面，介面上方為X方向設置，下方為Y方向設置。

A	X方向縮放率顯示
B	X方向實際長度值顯示
C	Y方向縮放率顯示
D	Y方向實際高度值顯示

通過數位鍵盤或+、-鍵輸入希望值，被輸入的數位插入到顯示數值的第一位，以前輸入的數字一位元一位元的累進，按下  
 確定鍵完成操作返回資料登錄介面。

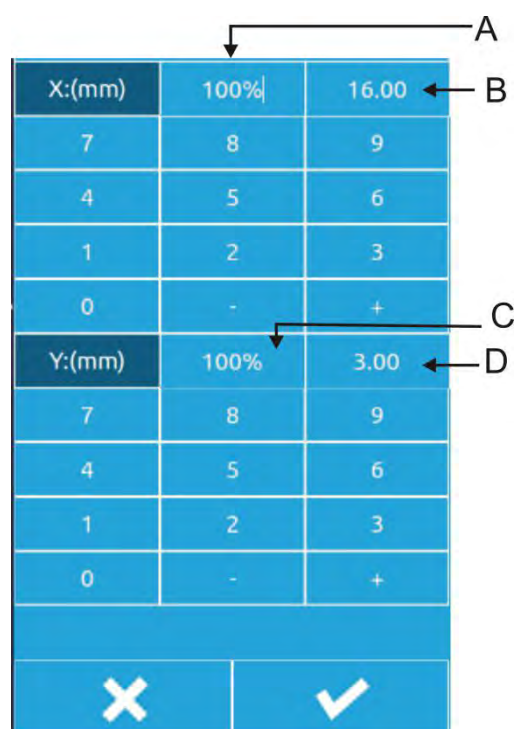

## ③ 速度值設定

操作同上

## ④ 中壓腳高度值設定

操作同上



## P 花樣登記





### ① 進入 P 花樣登記介面

在資料登錄介面下顯示普通花樣的情況下按下





進入 P 花樣登記介面，如右圖。

### ② 輸入 P 花樣號碼

通過  ~  十數位鍵盤或 、 鍵輸入想要登記的號碼，如果輸入了已經登記的花樣號碼，會提示此號碼已被佔用，這種情況下使用者需重新輸入想要登記的號碼。

### ③ 選擇資料夾號碼

P 花樣號碼可以登記到 26 個資料夾裡，每個資料夾最多保存 10 個 P 花樣。A 為當前所處資料夾，按 、 鍵可切換資料夾。

### ④ 確定花樣號碼

按下確定鍵  之後完成 P 花樣登記操作，返回到 P 花樣資料登錄介面，如圖所示。

### ⑤ 刪除 P 花樣

選中 P 花樣號碼，按下刪除鍵 ，即可刪除當前 P 花樣號碼。

### ⑥ 查看已登記 P 花樣

按以下兩個按鍵可以查看共登記了多少 P 花樣。

用戶最多可登記 255 個 P 花樣。



: P 花樣上翻頁



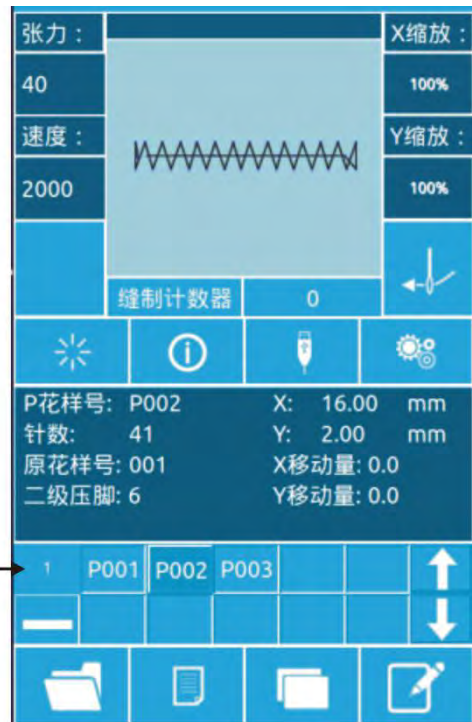
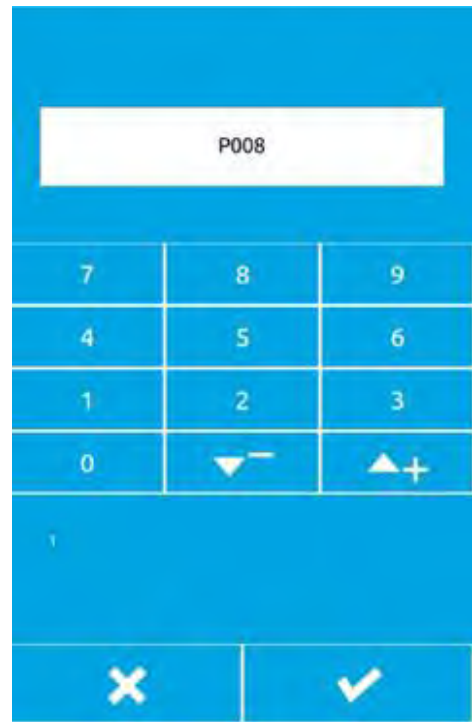

: P 花樣下翻頁



## 試縫操作

### ① 顯示縫製介面

在資料登錄介面，按準備鍵之後，準備鍵變為狀態，表示進入縫製介面。



### ② 顯示試縫介面

在縫製介面下，按下鍵後進入試縫介面（如右圖所示）：

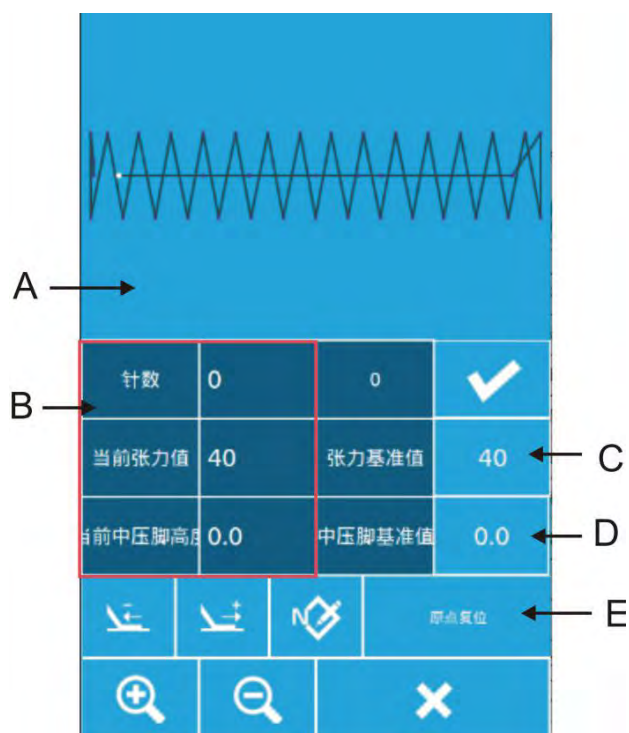
A	花样图案显示区域
B	花样信息显示区域
C	张力基准值设置按键
D	中压脚基准值设置按键
E	原点复位按键
	单针后退按钮
	单针前进按钮
	N针移动按钮
	剪线按钮
	图形显示放大按钮
	图形显示缩小按钮



### ③ 開始試縫

進入試縫介面後壓腳下降，用壓腳後退鍵和壓腳前進鍵確定形狀。

或應用 N 針前進按鈕直接移動到第 N 針。

### ④ 試縫介面啟動縫製

在試縫介面可以在任意位置直接踩踏啟動踏板，機器將從當前位置啟動縫製並返回縫製介面。

### ⑤ 結束試縫

按了取消鍵  退出試縫介面之後，返回縫製介面，並回到花樣起點位置。

## 計數器操作

### ① 顯示計數器介面

輸入介面或縫製介面中如圖 A、B 位置為計數器顯示位置

A	計數器模式按鍵	1：縫製計數器 2：針數計數器
B	計數值顯示按鍵	1：縫製件數 2：縫製針數

使用者可直接點擊 A 計數器模式按鍵快速切換“計件計數器/針數計數器”，在 B 按鍵位置處顯示相應“件數/針數”。

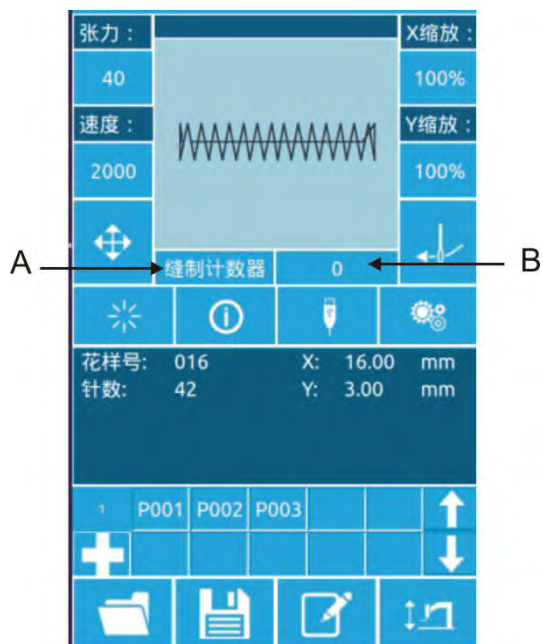

### ② 計數器清零操作

點擊按鍵 B，彈出重新計數介面，如圖所示，點擊 C 按鍵，計數器清零，並返回上一介面輸入介面/縫製介面。

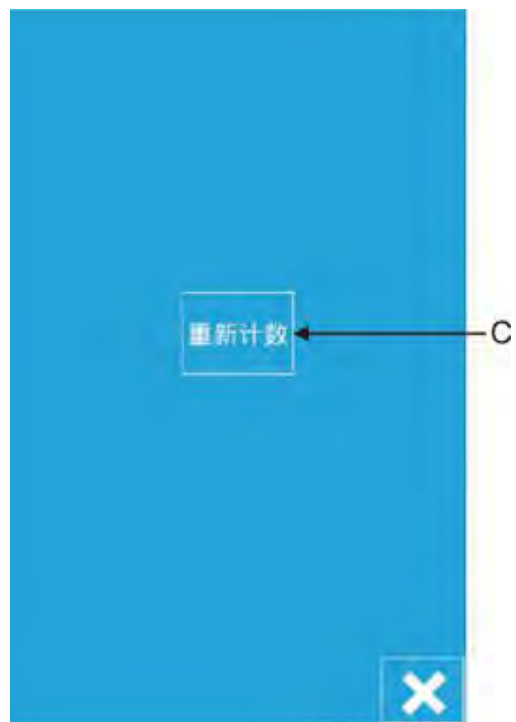

③ 設置計數器操作

在設置介面中點擊 D 按鍵，進入計數器設置介面



E	缝制计数器模式
F	计件当前计数值
G	缝制计数器最大值
H	针数计数器模式
I	针数计数当前值
J	针数计数器最大值

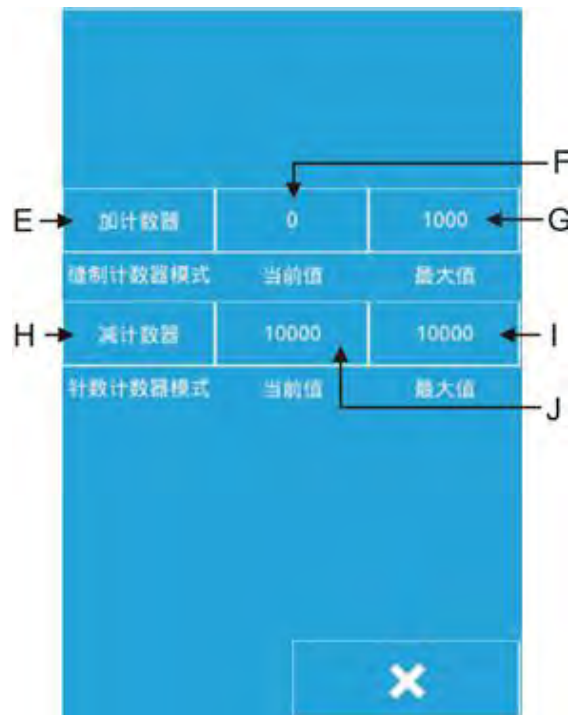





## 1. 設置計數器類型

點擊E 或 H 鍵進入計數器模式設置介面，  
可將模式設置成“加計數器/減計數器/  
不使用計數器”，模式設置完成後，按  
 鍵，返回上一介面。



## 2. 設定計數值

點擊 F/J 或 G/I, 可分別設定當前計數值和  
最大計數值，通過  ~   
十數位鍵盤或 、 鍵輸入數  
值。

注：縫製計數器最大值為 9999 件，針數  
計數器最大值為 65000 針。

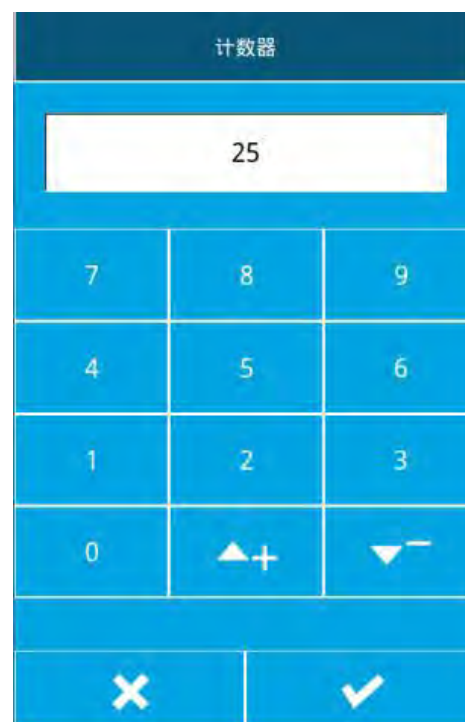

## 調整起縫點操作

### ① 進入調整起縫點介面

在資料登錄介面，按調整起縫點

按鍵之後，進入調整起縫點介面。如右圖。

A	模擬縫後退鍵
B	模擬縫前進鍵
C	當前所處針數
D	一次移動針數選擇鍵
E	調整量資料顯示
F	顯示繪圖區域
G	調整起縫點移動鍵盤
H	抬落中壓腳按鍵

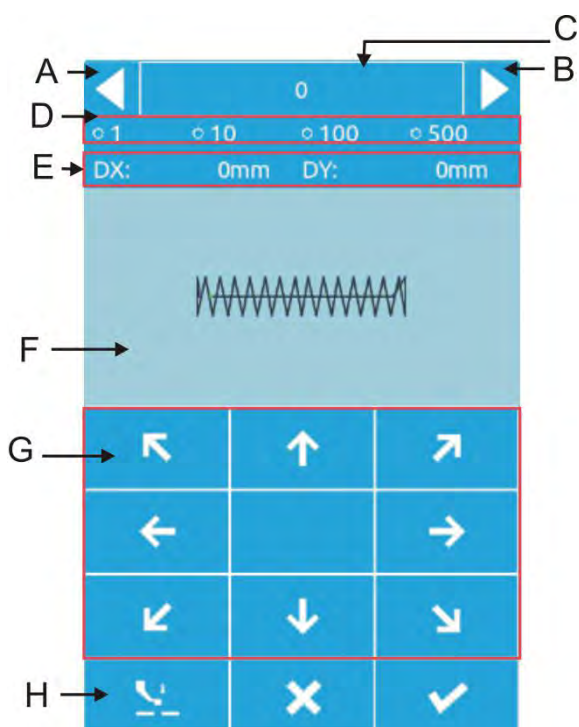

### ② 開始調整起縫點

按G區域的移動鍵盤移動起縫點，使機針對准範本的起縫點。對完起縫點以後，可以按A、B按鍵“類比走按鈕”，檢驗是否對準。

模擬走默認一次移動1針，可以通過點擊D區域選項按鈕，選擇一次移動10針、100針或500針。

注：起縫點已經對準的標準是：機針與花樣的縫製軌跡沒有偏差，若存在偏差說明仍需繼續調整，確認調整完畢後按鍵確認即可保存偏移量。

### ③ 結束試縫

按了取消鍵退出調整介面之後，返回輸入介面。

## 急停

急停開關被按下後，按確認鍵後進入是縫製介面，可通過試縫製介面進行針數前進、後退或剪線等操作，操作步驟參照【2.11 試縫製操作】

### 3 快捷 (P) 花樣操作

#### P 花樣資料登錄

快捷花樣簡稱 P 花樣，由一個普通花樣和相關花樣縫製參數 (X 縮放率、Y 縮放率、速度限制等) 組成。選用 P 花樣不需要每次設置相關參數。

P 花樣資料登錄介面如右圖所示。

最多可以登記 255 個 P 花樣。

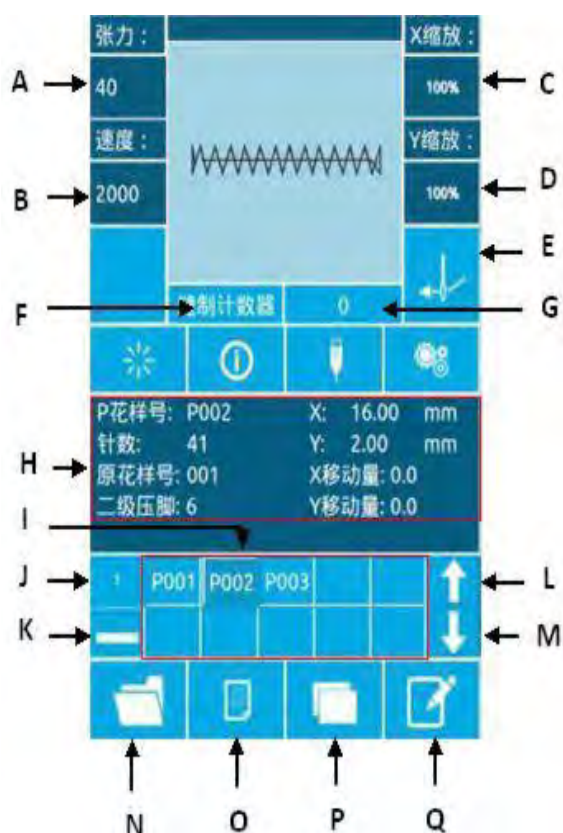

#### 功能說明：

序號	功能	內容
A	張力值	顯示當前花樣張力
B	速度值	顯示當前花樣速度值
C	X 縮放率	最多可以輸入 14 個字元。
D	Y 縮放率	按下之後外壓腳下降。
E	穿線	按下後顯示紅色  為穿線狀態，不可進行其他操作
F	計數器模式	分為縫製計數器和針數計數器，點擊按鍵可快速切換計數器模式及計數顯示
G	計數器值	根據計數器模式的不同，顯示相應的當前計數值

序號	功能	內容
H	P 花樣資訊顯示	顯示為當前 P 花樣縫製資訊。
I	已登記的 P 花樣	按鍵可快捷切換 P 花樣。
J	P 花樣頁數	顯示當前 P 花樣所處頁數，按鍵可順序切換 P 花樣頁碼。
K	P 花樣刪除鍵	點擊該按鍵可刪除選中的 P 花樣。
L	P 花樣上翻頁	點擊按鍵 P 花樣上翻頁
M	P 花樣下翻頁	點擊按鍵 P 花樣下翻頁
N	普通花樣選擇鍵	點擊按鍵可選擇已登記的普通花樣
O	普通花樣登記按鍵	登記新的普通花樣
P	P 花樣複製按鍵	可以複製當前 P 花樣內容到一個空花樣號碼下
Q	花樣命名鍵	可以為當前花樣命名

## P 花樣編輯

### ① 進入 P 花樣編輯介面

按  鍵進入 P 花樣編輯介面（如右圖所示）

### ② 編輯專案資料變更

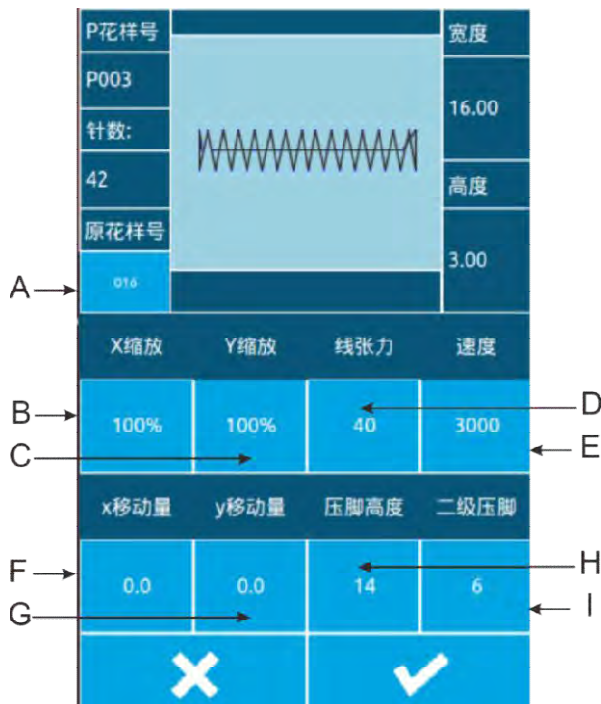

選擇想要變更的項目，設置數值。

	項目	輸入範圍	初始值
A	花樣原號碼	---	---
B	X方向縮放	1%~400%	100.0%
C	Y方向縮放	1%~400%	100.0%
D	縫製張力	0~120	40
E	縫製速度	400~2800rpm	2000rpm
F	X偏移量	-99.9~99.9	0.0mm
G	Y偏移量	-99.9~99.9	0.0mm
H	中壓腳高度	0.0~7.0mm	2.0mm
I	二級壓腳	0~10	6mm



### ③ 確定資料變更

以設置 X 方向偏移量為例，通過 

~  十數位鍵盤或 、

 鍵輸入數值，按下確定鍵

 完成操作。

   
  : 代表正負數值；



### ④ 退出編輯

按下逸出鍵  關閉 P 花樣編輯介面，返回資料登錄介面。

## P 花樣複製

### ① 選擇被複製花樣

按下  進入P花樣複製介面（如右圖所示）。

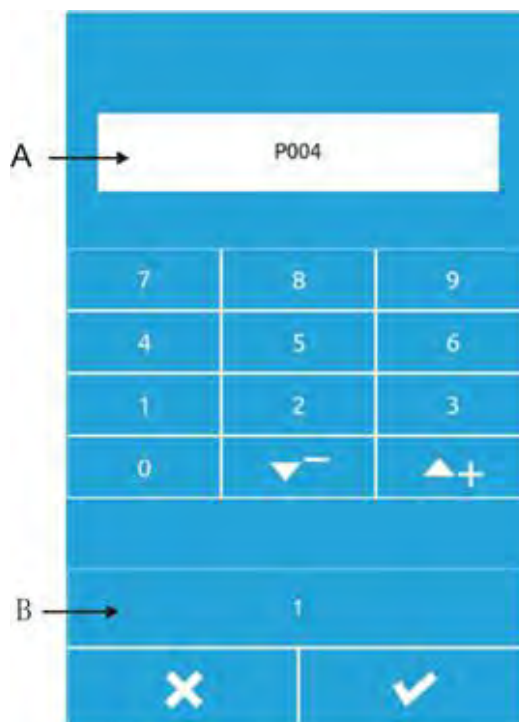



### ② 輸入新登記的花樣號碼

A為被系統自動選取的空號碼，B為所

處頁數，用戶可直接  將當前P花樣複製到該號碼上；也可通過

 ~  十數位鍵盤或

、 鍵輸入想要複製的目的號碼，已經登記的花樣號碼不能重複登記，系統會提示錯誤。

B按鍵可改變所處頁數，按  鍵確認複製，並返回P花樣輸入介面。

## P 花樣縫製

在 P 花樣資料登錄介面下，按下



進入縫製介面。

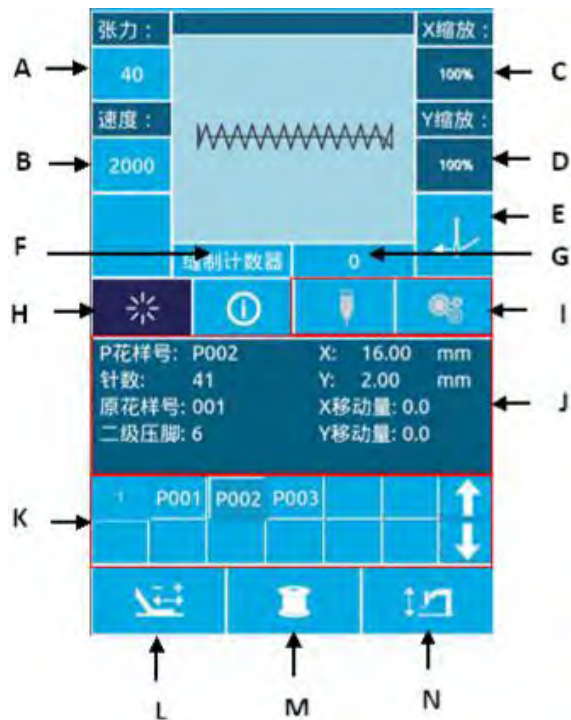

### 功能說明：

序號	功能	內容
A	張力按鍵	按下後進入張力設置介面，可以設定縫製張力值。
B	速度按鍵	設定當前縫製速度。
C	X 方向縮放顯示	顯示當前花樣的 X 縮放率。
D	Y 方向縮放顯示	顯示當前花樣的 Y 縮放率。
E	穿線按鍵	按下後按鍵呈紅色  ，進入穿線狀態，此時不可進行其他操作。
F	計數器模式按鍵	按下後可快速切換“縫製計數器/針數計數器”。
G	計數顯示按鍵	根據 F 按鍵的模式不同，顯示相應的計數，按下後可進入清零界面，可將當前計數清零。
H	花樣確認鍵	切換“花樣輸入狀態/縫製狀態”。
I	不可操作按鍵	當前狀態不可操作。
J	花樣資訊顯示	顯示當前花樣的參數值。

---

序號	功能	內容
K	不可操作按鍵	當前狀態不可操作。
L	試縫製按鍵	按下按鍵後可進入試縫製介面，確認花樣針跡。
M	繞線按鍵	按下後進入繞線介面。
N	中壓腳高度按鍵	按下後進入中壓腳高度設定介面，可設定縫製的中壓腳高度。

## 4 組合 (C) 花樣操作

### C 花樣資料登錄

組合花樣簡稱 C 花樣，由一組 P 花樣組成，每組 C 花樣可以輸入最多 6 個子花樣。一共可以登記最多 50 組 C 花樣。

如右圖所示。

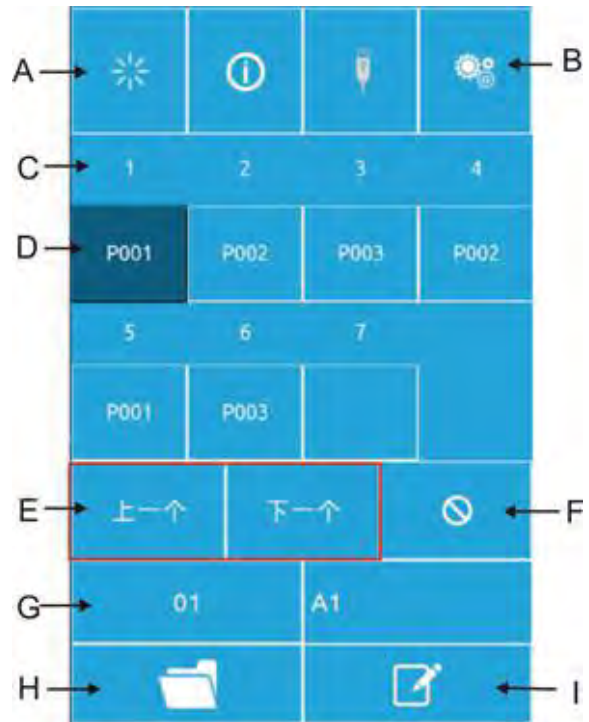

---

## 功能說明：

序號	功能	內容
A	確認鍵	進入縫製狀態
B	C 花樣複製	可以複製當前 C 花樣內容到一個空花樣號碼下。
C	縫製順序顯示	顯示當前選擇花樣的縫製順序，藍色顯示為起始縫製圖案。
D	C 花樣圖案選擇	按下後進入 C 花樣編輯介面，可以選擇輸入一個 P 花樣。
E	翻頁鍵	C 花樣圖案最多可以登記 30 個，每頁最多顯示 6 個圖案。
F	刪除鍵	刪除 C 花樣序列
G	C 花樣號碼選擇	按鍵上顯示當前選擇花樣號碼，按下後進入 C 花樣選擇介面。
H	C 花樣登記	登記一個新組合花樣。
I	花樣命名	輸入想要命名的字串
J	C 花樣名稱	顯示 C 花樣名稱。

## C 花樣編輯

### ① 進入 C 花樣編輯介面

在 C 花樣資料登錄介面下，按下 A 可以進入 C 花樣編輯介面。

在初期狀態下，沒有登記到 P 花樣做為縫製圖案，因此第一個圖案以空白狀態顯示。

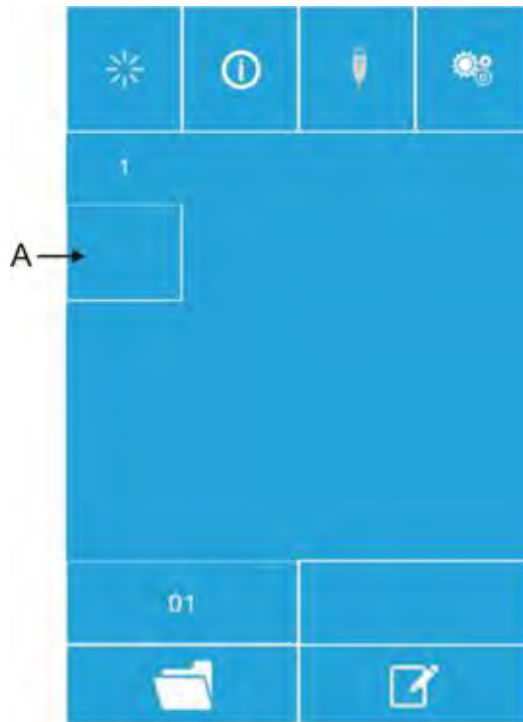

### ② 選擇圖案

右圖為 C 花樣編輯介面，選擇想要登記的 B 區域的 P 花樣圖案，按下確定

鍵  之後結束選擇。

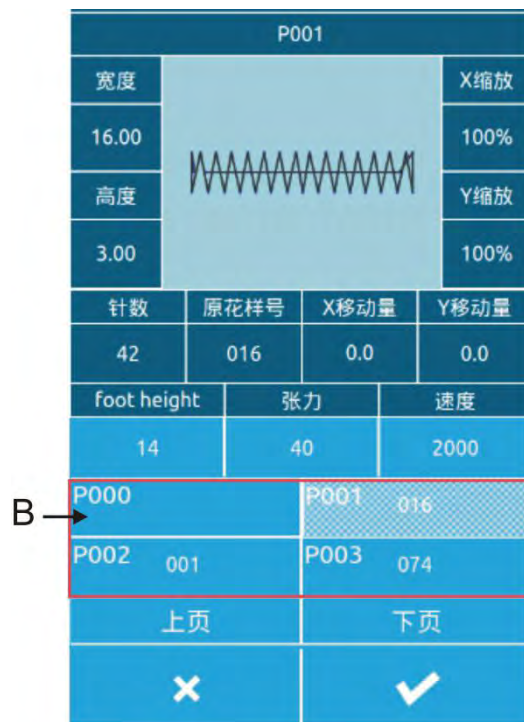

### ③ 反復登記剩餘圖案

一個圖案登記確定之後，下一個圖案選擇鍵 C 被顯示出來如上圖，操作同上，可以反復登記其它剩餘圖案。

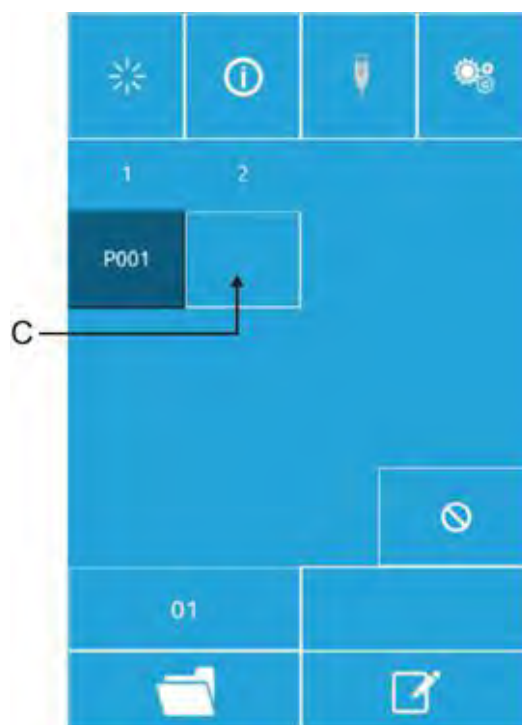

## C 花樣選擇

### ① 進入 C 花樣選擇介面

如右圖所示，按下圖示 A，可以進入 C 花樣選擇介面。

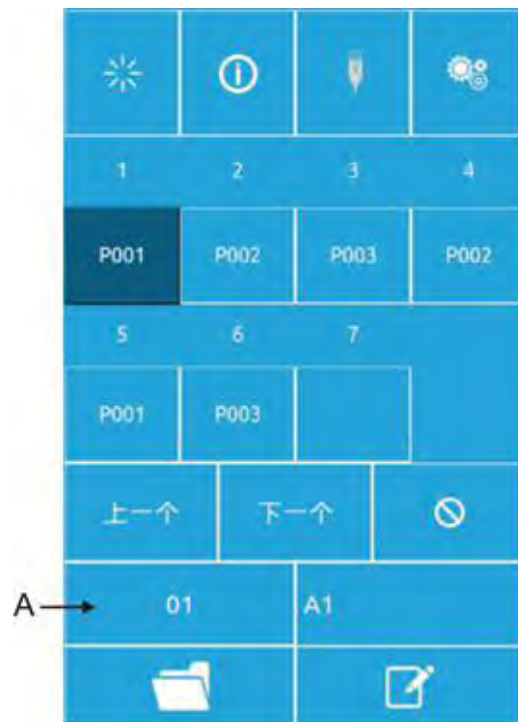

### ② 選擇 C 花樣號碼

右圖為 C 花樣選擇介面，按下 B 鍵之後，可以順序變換當前 C 花樣下輸入的 P 子花樣資料資訊。

確定要選擇的 C 花樣號碼鍵 C，按

下確定鍵  之後結束選擇。

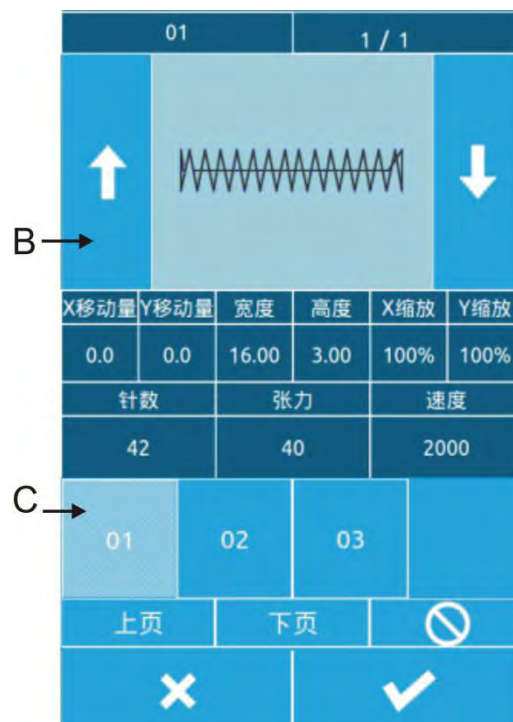

## C 花樣縫製

在 C 花樣資料登錄介面下，按下  進入縫製介面（如右圖所示）。

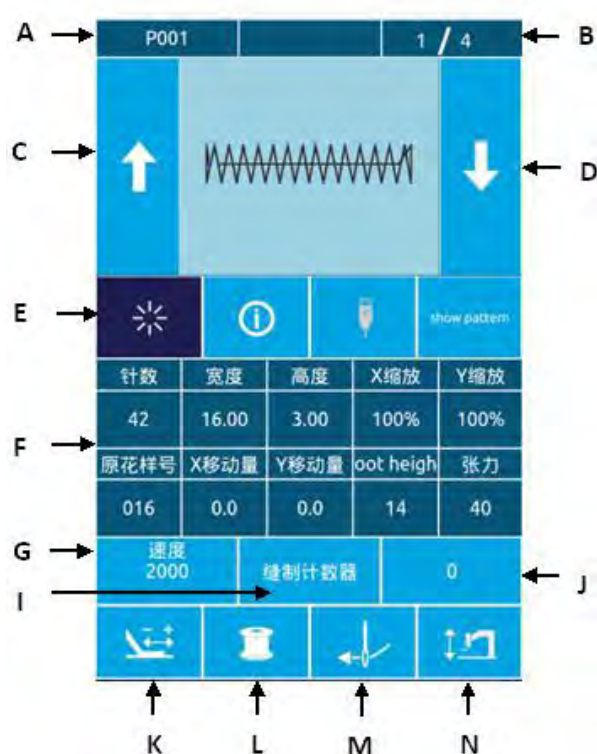

### 功能說明：

序號	功能	內容
A	縫紉形狀號碼顯示	顯示當前 C 花樣下登記的子花樣號碼。
B	縫製順序顯示	顯示當前縫製花樣中的縫製順序號
C	縫製花樣切換鍵	按下後縫製花樣切換到當前序列的上一個花樣。
D	縫製花樣切換鍵	按下後縫製花樣切換到當前序列的下一個花樣。
E	花樣確認鍵	切換 C 花樣輸入介面狀態和縫製介面狀態。
F	花樣資訊顯示	顯示當前縫製序列中當前子花樣的參數資訊。
G	縫製速度鍵	設定當前縫製序列中當前子花樣的縫製速度。
H	中壓腳高度按鍵	設定當前縫製序列中當前子花樣的中壓腳高度。

序號	功能	內容
I	計數器模式按鍵	設定當前計數模式，“縫製計數/針數計數”。
J	花樣計數顯示	根據 I 的設定不同，顯示相應計數“件數針數”。
K	試縫製按鍵	按下後進入試縫製介面，確認當前縫製序列中當前子花樣的針跡走勢。
L	繞線按鍵	按下後進入繞線介面。
M	穿線按鍵	按下後按鍵呈紅色  ，進入穿線狀態，此時不可進行其他操作。
N	中壓腳抬落按鍵	可控制中壓腳的抬落。

## 5 花樣圖案編輯

### 進入花樣編輯模式

按下普通縫製可以切換資料登錄介面和模式選擇介面(如右圖所示),在該介面下可以進行一些詳細的設置和編輯操作。

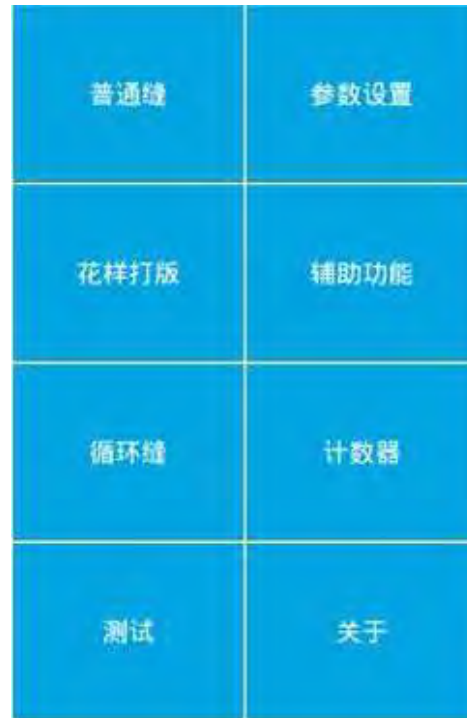



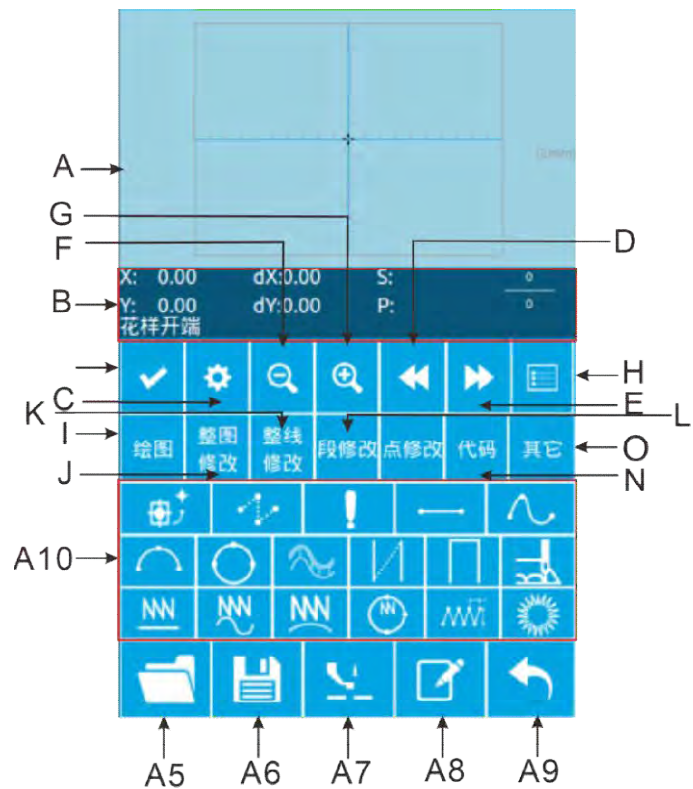













按下花样打版鍵進入花樣編輯介面。



## 功能說明：

序號	功能	內容
A	花樣顯示區	顯示花樣圖案
B	當前針位置狀態資訊顯示區	顯示當前針的位置資訊
C	屬性設置	可以設置回針等屬性
D	後退送布	將當前針位置向後移動
E	前進送布	將當前針位置向前移動
F	縮小顯示	將花樣圖案縮小顯示
G	放大顯示	將花樣圖案放大顯示
H	功能列表	以清單的形式顯示出打版中的功能
I	繪圖	A10 區域顯示出繪圖相關按鈕
J	整圖修改	A10 區域顯示出整圖修改相關按鈕
K	整線修改	A10 區域顯示出整線修改相關按鈕
L	段修改	A10 區域顯示出段修改相關按鈕
M	點修改	A10 區域顯示出點修改相關按鈕
N	功能碼	A10 區域顯示出功能碼相關按鈕
O	其它	A10 區域顯示出其它相關按鈕
A5	打開	打開花樣文件
A6	保存	將當前顯示圖案保存為花樣檔
A7	中壓腳升降	抬升或下降中壓腳
A8	命名	為花樣命名
A9	退出	退出打版
A10	動態按鈕顯示區	根據按鈕(I、G、K、L、M、N、O)不同的選擇，顯示對應相關按鈕。

序號	功能	內容
	空送	繪製空送
	點縫	繪製點縫
	直線縫	繪製直線
	曲線縫	繪製曲線
	圓弧縫	繪製圓弧
	圓縫	繪製圓
	多重縫	繪製多重縫
	同向雙重縫	繪製同向雙重縫
	逆向雙重縫	繪製逆向雙重縫
	直線曲折縫	繪製直線曲折縫
	曲線曲折縫	繪製曲線曲折縫
	圓弧曲折縫	繪製圓弧曲折縫
	圓曲折縫	繪製圓曲折縫
	直線曲折縫 2	繪製直線曲折縫 2(每段可設置多個點)
	跳縫	繪製跳縫
	範本	繪製範本
	第二原點	添加第二原點

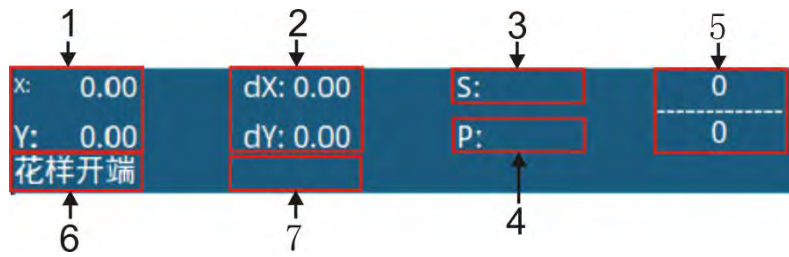

序號	項目	內容
1	絕對座標	表示從現在的機針位置的原點的絕對座標。
2	相對座標	表示現在的機針位置的相對座標。
3	速度	表示當前點的縫製速度或空送速度。
4	間隔	表示現在的要素縫製針跡長度。
5	針數	分子表示當前針數，分母表示總針數。
6	落針種類	表示有關落針位置的種類。
		花樣開端，表示是圖案的起點位置。
		線段中間點，表示是一條線的中途點（即不是頂點也不是線段終端）。
		頂點，表示是折線的頂點。
		線段終端，表示是一條線的終端位置。
6	落針種類	花樣終端，表示是圖案的最終位置。
7	線或功能碼種類	縫製資料時，顯示該線種類(空送、折線縫、曲線縫等)。功能碼時，顯示該功能碼的種類(切線等)。

## 花樣編輯

使用花樣編輯功能，輸入如下花樣圖案。

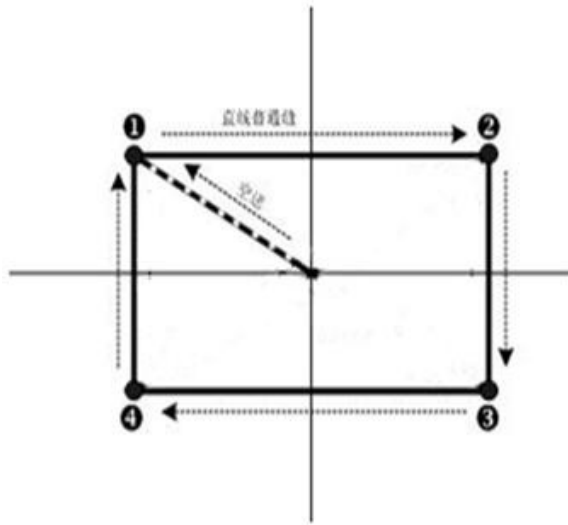

輸入點：

	X (mm)	Y (mm)
1	-10.00	8.00
2	10.00	8.00
3	10.00	-8.00
4	-10.00	-8.00

輸入次序：如左圖中虛線箭頭所示。

### ①空送的輸入

在花樣編輯標準介面，按空送按鈕 ，顯示出空送設定介面(如右圖所示)。

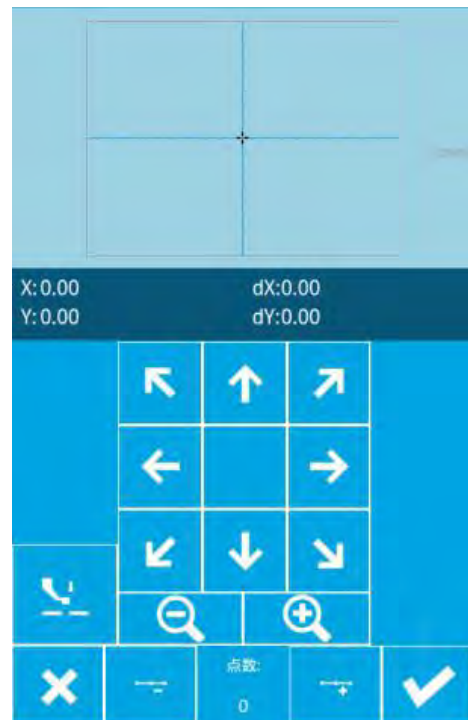

在空送位置指定介面，使用移動鍵，移動游

標（機針位置）到（-10，8）處，按  按鈕確定後，退回到花樣編輯標準介面並顯示出空送針跡(如右圖所示)。

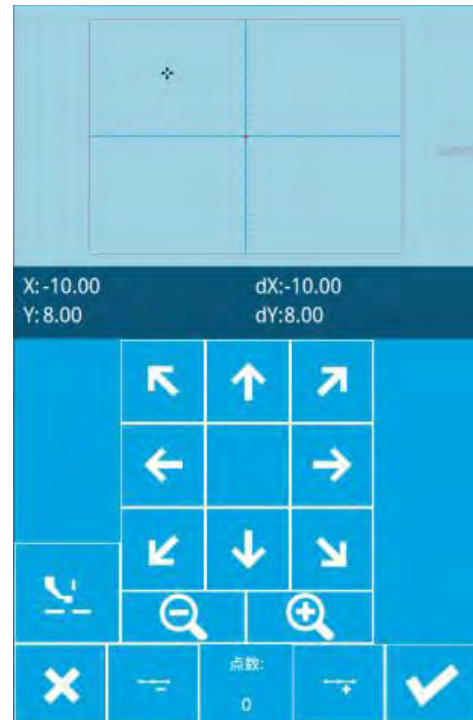

## ②直線普通縫的輸入

在花樣編輯標準界面按直線縫鍵  後，進入直線普通縫針距設置介面，如右圖所示。依次按 2、0 數字鍵，將縫跡長度變更為“2.0”，按確認鍵保存並退回到直線普通縫設置介面。

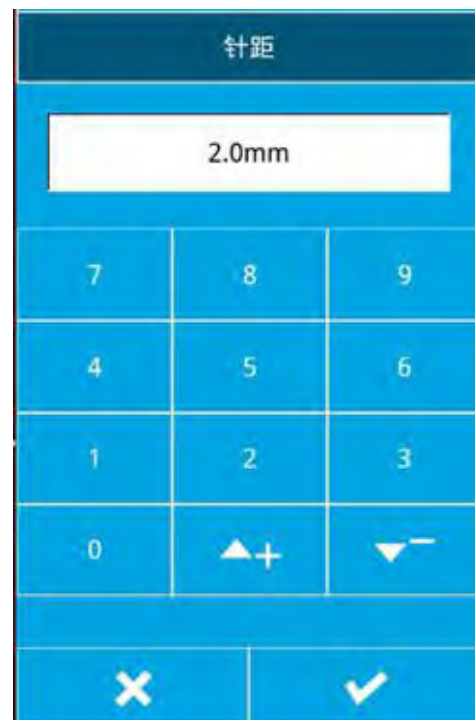

確認針距的顯示值為“2.0mm”之後，按確認鍵，進入直線普通縫位置設定介面。

在此介面下，按移動鍵，將游標（機針位置）從1處移動到2處，然後按插入點按鈕。反復進行上述移動操作，將光標按照

1 2 3 4 的順序依次移動，如右圖所示。

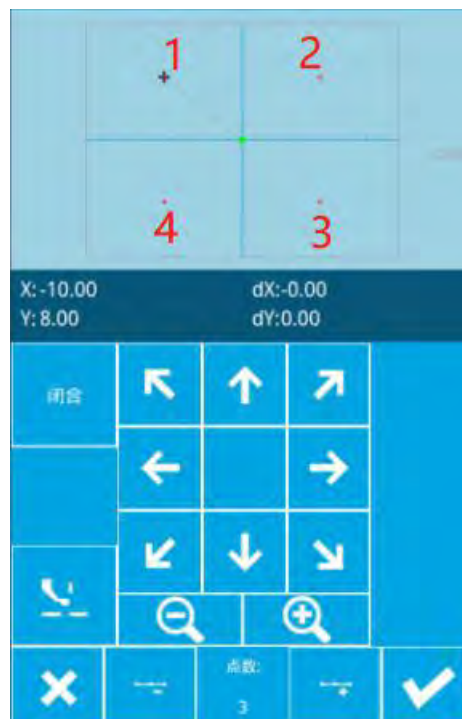

確認花樣圖案後，按鍵生成花樣資料並返回到花樣編輯標準介面，顯示出花樣圖案。

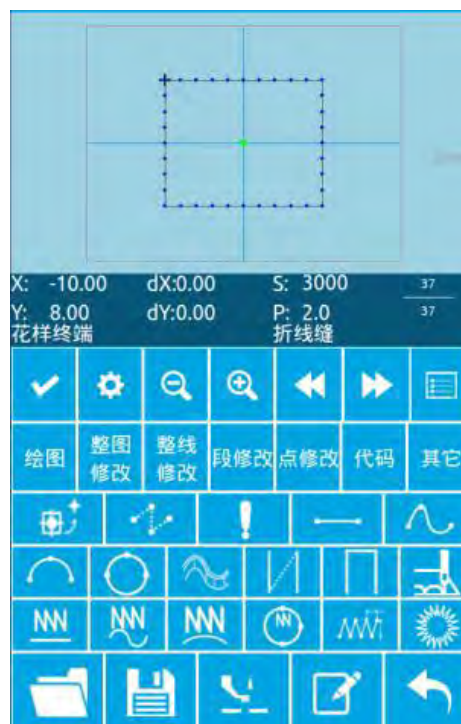

### ③保存花樣

按  按鈕，進入圖案花樣保存介面，保存編輯好的花樣圖案，如右圖所示。

系統自動設定好樣號碼，使用者也可以通過數位鍵盤輸入希望值。按  鍵後保存花樣圖案。

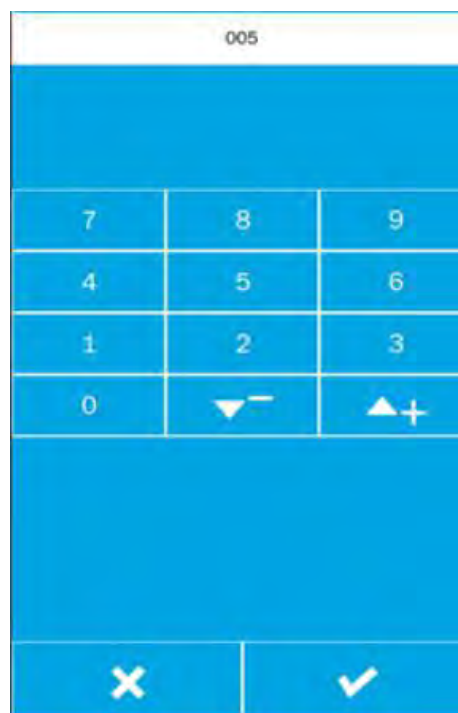

## 花樣的修改

### 1：繪圖

- (A): 繪製空送
- (B): 繪製點縫
- (C): 繪製直線
- (D): 繪製曲線
- (E): 繪製圓弧
- (F): 繪製圓
- (G): 繪製多重縫
- (H): 繪製同向雙重縫
- (I): 繪製第二原點
- (J): 繪製逆向雙重縫
- (K): 繪製曲線曲折縫
- (L): 繪製圓弧曲折縫
- (M): 繪製圓曲折縫
- (N): 繪製直線曲折縫 2(每段可設置多個點)
- (O): 繪製跳縫
- (P): 繪製直線曲折縫 1
- (Q): 繪製範本

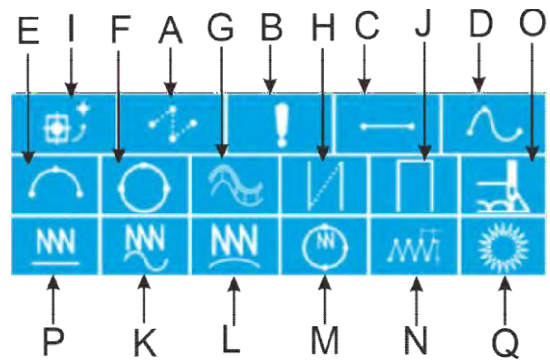

### 2： 整圖修改：按整圖修改按鈕動態按鈕顯示區顯示如下功能按鈕：

- (A):移動起縫點按鈕
- (B):修改整個圖形針距
- (C):刪除
- (D):複製
- (E):原點鏡像
- (F):X 鏡像
- (G):Y 鏡像
- (H):旋轉複製
- (I):旋轉
- (J):清理空送(保留次原點)
- (K):清理空送和次原點

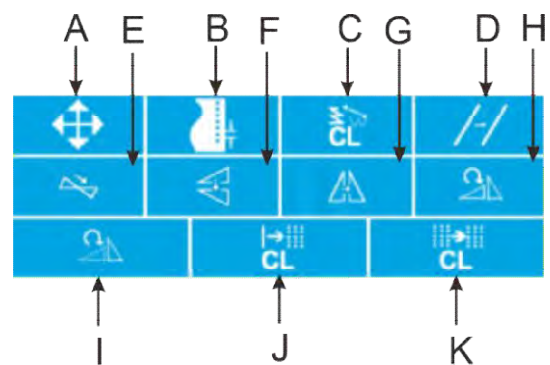

### 3： 整線修改按鈕：按整線修改按鈕動態按鈕顯示區顯示如下功能按鈕：

- (A):修改當前線的針距
- (B):移動當前線
- (C): 移動多條線
- (D):複製當前線
- (E):刪除當前線
- (F): 移動當前線和後面所有線
- (H):X 鏡像
- (I):Y 鏡像
- (J):原點鏡像

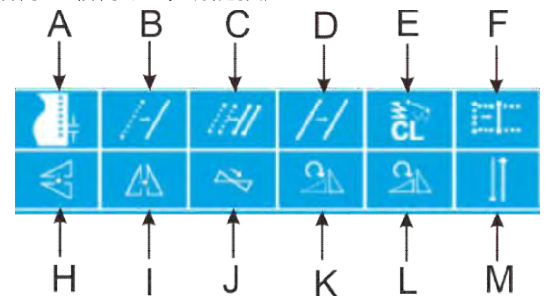

- (K):旋轉
- (L):旋轉複製
- (M):翻轉

4: 段修改按鈕：按段修改按鈕動態按鈕顯示區顯示如下功能按鈕：

- (A):區段移動
- (B):區段修改
- (C):區段刪除

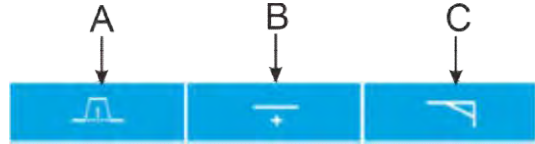

5: 點修改按鈕：按點修改按鈕動態按鈕顯示區顯示如下功能按鈕：

- (A):移動點
- (B):添加點
- (C):刪除點
- (D):添加空送點

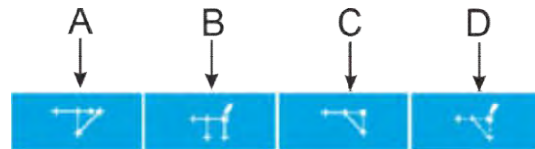

6: 功能碼按鈕：按功能碼按鈕動態按鈕顯示區顯示如下功能按鈕：

- (A):剪線
- (B): 中途停止
- (C):線張力基準值
- (D):中壓腳高度基準值
- (E): 線張力
- (F):中壓腳高度
- (G):刪除功能碼 (H):
- 改變縫製速度 (I):
- 改變空送速度 (J):
- 外部輸入
- (K):外部輸出
- (L):編輯功能碼
- (M): 側滑，翻轉和其他專用擴展設備。

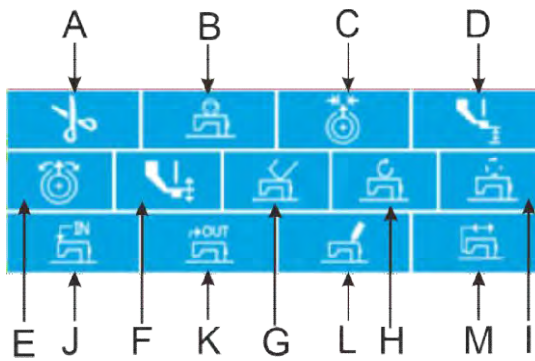

7: 其它：按其它按鈕動態按鈕顯示區顯示如下功能按鈕：

- (A):移動到指定針
- (B):更換範本功能
- (C):移動空送

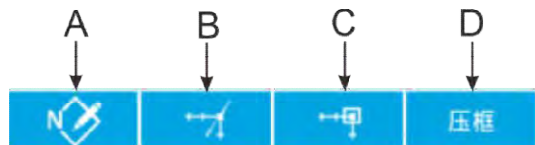

## 退出花樣編輯模式

在花樣編輯標準介面下，按  進入模式選擇介面，如右圖所示。

普通縫	参数设置
花样打版	辅助功能
循环缝	计数器
测试	关于

---

## 6 資訊功能

### 查看版本資訊

#### 1 顯示資訊介面

在資料登錄介面，按如右圖所示的資訊按鍵（A）之後，資訊介面被顯示出來。

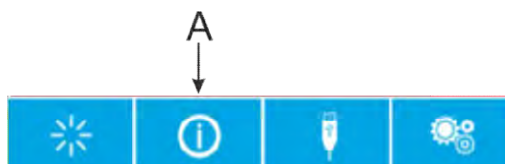

#### 2 顯示版本介面。

請按資訊介面的版本按鍵，版本介面被顯示出來。在版本介面上，可以查看版本資訊。



## 7 通訊功能

通信功能完成以下幾項功能：

- 將其它縫紉機編制的或打版軟體編制的縫製資料通過U盤拷貝到操作面板；
- 將操作面板裡面的縫製資料拷貝到U盤。

### 關於可以處理的資料

可以處理的縫製資料如下：

資料類型	標準格式
VDT	VD00[0-9][0-9][1-9].VDT
sew	ISMS0[0-9][0-9][1-9].sew

### 花樣傳輸

#### 1. 從 U 盤拷貝花樣檔到操作盤

在資料登錄介面，按通信鍵之後，顯示出通信介面，如右圖所示。

1) 選中按鈕，這個按鈕表示從U盤拷貝花樣檔到操作盤；

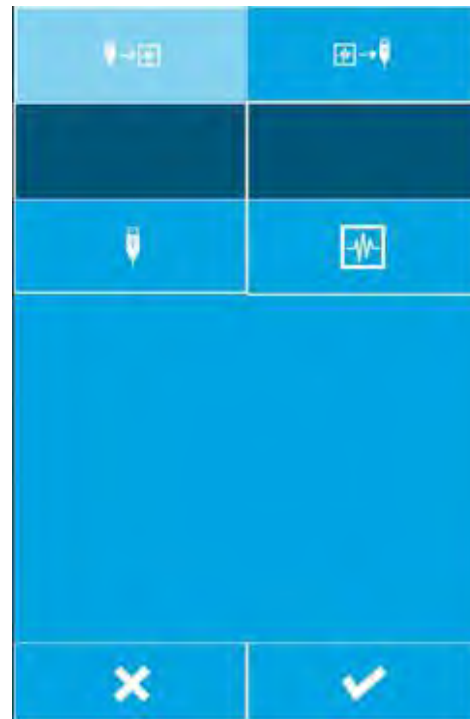

2) 按U盤按鈕  顯示出選擇U盤檔介面，如右圖所示。找到需要複製的檔按確定按鈕



3) 按操作盤按鈕  ，顯示出輸入檔號介面，如右圖所示，這個檔號是檔拷貝到操作盤以後的檔號，輸入檔號以後按確定按鈕





4) 從 U 盤選擇好檔並且輸入完操作盤檔號

以後，如右圖所示，按確定按鈕 ，這樣就可以將U 盤中的檔拷貝到操作盤。





## 2. 從操作盤拷貝檔保存到 U 盤



在資料登錄介面，按通信鍵  之後，顯示出通信介面，如右圖所示。

1) 選中  按鈕，這個按鈕表示從操作盤拷貝花樣檔到U盤；

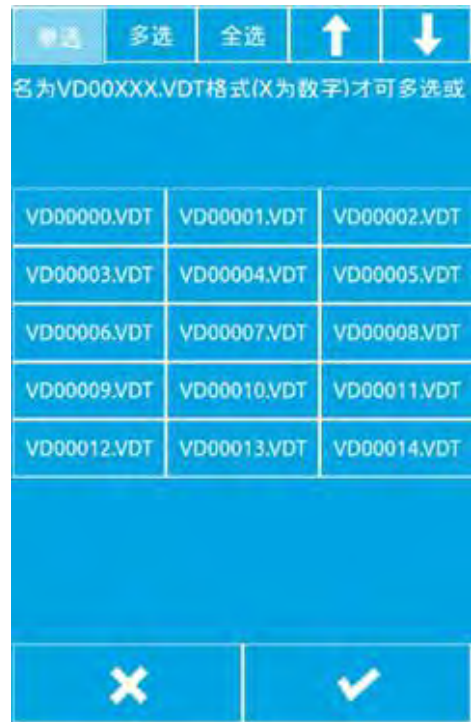

2) 按操作盤按鈕 ，顯示出選擇操作盤檔介面，如右圖所示。找到需要複製的檔，按確定按鈕 。



3) 按 U 盤按鈕 ，顯示出輸入檔號介面，如右圖所示。這個檔號是檔拷貝到 U 盤以後的檔號，輸入檔號以後按確定按鈕 。

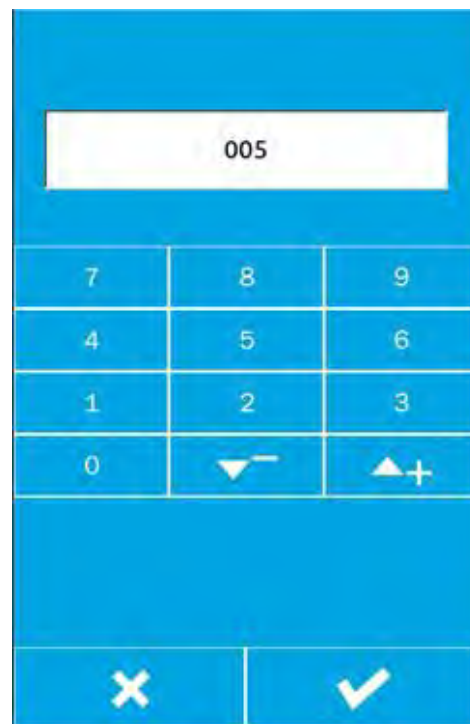

4) 從操作盤選擇好檔並且輸入完 U 盤檔號以

後，如右圖所示，按確定按鈕 ，這樣就可以將操作盤中的檔拷貝到 U 盤。



## 8 模式和參數設置

### 模式切換

普通縫製介面按下  可以進入設置介面（如右圖所示），在該介面下可以進行模式切換和設置。

三種模式：普通縫模式，花樣打版模式，迴圈縫模式。

#### 普通縫模式

按普通縫鍵進入普通縫製介面，切換到普通縫模式。

#### 花樣打版模式

按花樣打版鍵進入花樣打版介面，切換到打版模式，在花樣打版介面可以自己畫圖、編輯花樣、修改花樣等。

#### 迴圈縫模式

按迴圈縫鍵進入迴圈縫製介面，切換到迴圈模式。

普通縫	参数设置
花样打版	辅助功能
循环缝	计数器
测试	关于

## 測試

按測試鍵進入測試介面，如右圖所示。



## 輸入測試

按輸入測試鍵進入輸入測試介面，如右圖所示，可以查看 X 原點，Y 原點，踏板開關，急停開關，斷線檢測的狀態。



## 動作測試

按動作測試鍵進入動作測試介面，如右圖所示。  
可以測試 X 軸移動動作、Y 軸移動動作、剪線動作、中壓腳動作、穿線動作。

 : X 軸移動鍵

 : Y 軸移動鍵

 : 中壓腳鍵

 : 張力器鍵

選中需要測試的動作鍵，然後點加號鍵、減號鍵，如果對應機器部件有動作說明此動作

能夠正常執行，按  鍵關閉測試。

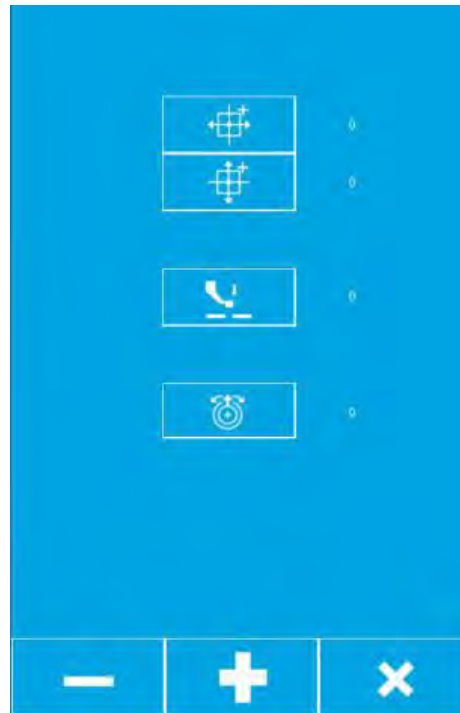

## 輸出測試

按輸出測試鍵進入輸出測試介面，如圖所示，選擇輸出口後，按加、減號鍵，如果對應輸出口的氣閥有動作，說明此輸出口可

以正常工作，測試完成後按  鍵關閉測試。



## 外部輸出測試

按外部輸出測試鍵進入外部輸出測試介面，如圖所示，選擇外部輸出口後，按加、減號鍵，如果擴展板上對應的外部輸出口的氣閥有動作，說明此外部輸出口可以正常工作，

測試完成後按  鍵關閉測試。

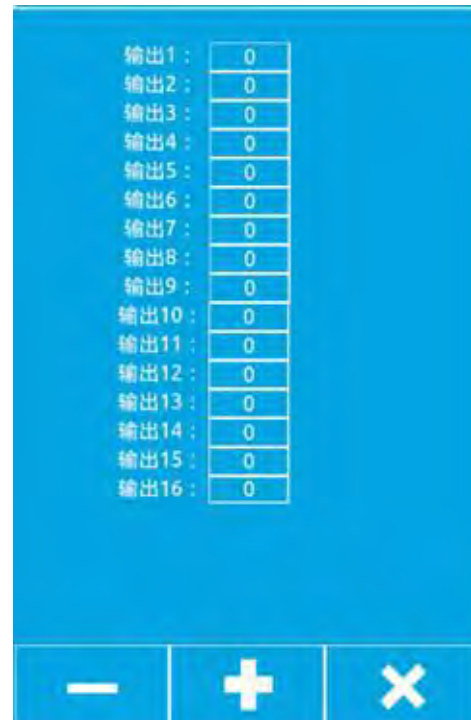

## 主軸角度測試

按主軸角度測試鍵進入主軸角度測試介面，如下圖所示，可以查看當前的主軸角度，轉動機器的主軸，則主軸角度會隨著轉動而變化。

主軸角度：0

## 模擬踏板校準

按輸入測試鍵進入輸入測試介面，如右圖所示，點擊按鍵 A 進入類比踏板校準介面

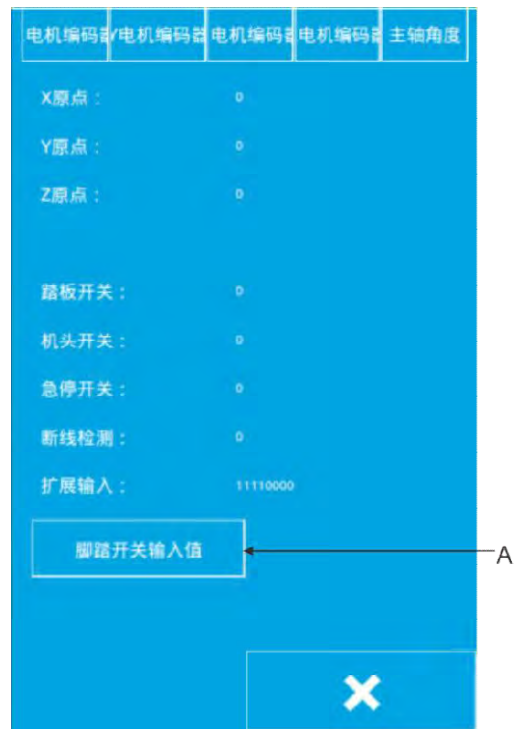

類比踏板校準介面如右圖所示





B : 當前踏板踩踏量

C : 踏板下踩最大量

D : 鬆開踏板的平衡位置

E : 踏板倒踩最大量

踏板校準方法：

1. 按下按鈕 C 使處於按下狀態，踩踏板至最大量，按下 ，保存當前踏板輸入值；
2. 按下按鈕 D 使按鍵處於按下狀態，鬆開踏板使踏板處於平衡狀態，再次按下 ，保存當前踏板輸入值；
3. 按鈕 E 使按鍵處於按下狀態，踏板倒踩值最大狀態再次按下 ，保存當前踏板輸入值。
4. 保存三個踏板輸入值後，踏板校準完成按  鍵退出當前介面。

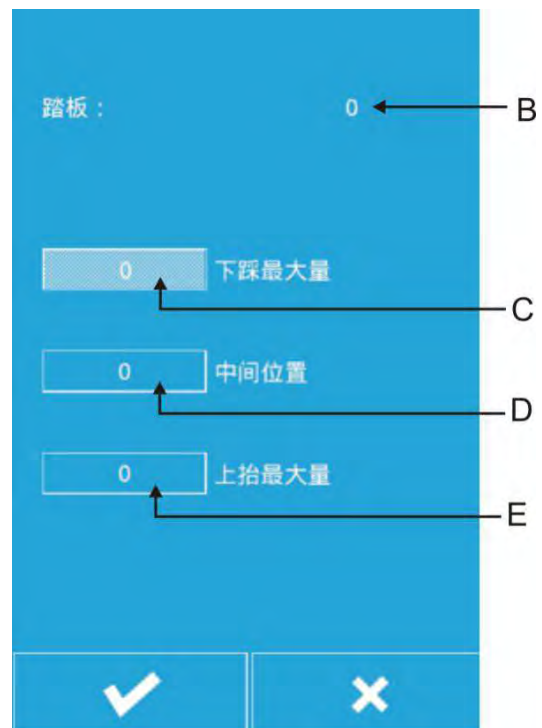

## 參數設置

點擊參數設置按鈕進入參數設置介面，如下圖所示。參數設置主要功能是一些機器參數的設置和一些選項的設定。其中基本設置 1 中是一些比較常用的設置一般與控制板有關，基本設置 2 中的設置一般與控制板無關，只與面板有關，高級設置中是一些比較重要的設置，需要高級許可權的使用者通過輸入密碼才能進行設置，超級設置一般只有具有超級許可權的廠家技術人員才能進行設置。



### 基本設置 1

點擊基本設置 1 中的進入按鈕，進入到常用基本參數設置介面，如下圖所示，通過



鍵進行前後翻頁，選中需要

更改的參數按鈕，通過



鍵可以查詢被

選中參數的詳細資訊，然後通過



鍵可以調整參數的值，設置好參數值

以後點擊



鍵，確保更改生效，點擊



鍵退出常用基本參數設置介面。



The image shows a blue background with a table of parameters. The table has three columns: a parameter ID, a value, and a description. Below the table are several navigation buttons: a minus sign, a plus sign, an up arrow, a down arrow, an information icon, a close button (X), and a checkmark button.

001	1	压框上升时间
054	0	间歇压脚下降时间
070	1	使用的脚踏控制器开关
150	OFF	倒缝针抬起
151	400	缝纫开始第1针的速度
152	800	缝纫开始第2针的速度
153	1200	缝纫开始第3针的速度
154	1500	缝纫开始第4针的速度
155	2000	缝纫开始第5针的速度
156	3200	缝纫结束前5针的速度

基本設置 1 參數說明如下表所示：

序號	設定範圍	初始值	設定單位	設定內容
1	OFF/1/2	1	-	壓框上升時間： 縫紉完成後壓框上升時間 OFF:不自動上升 1:在最後一針的位置上升 2:移動到縫紉開始處後上升
50	0~12	0	1	壓腳工作模式 0：標準模式 1-7：預留 8：一段式電動踏板 9-11：預留 12：一鍵啟動
54	0~2	0	1	間歇壓腳的下降時間： 0:通過壓腳開關聯動下降，但在送布退避位置不下降 1: 通過壓腳開關聯動下降 2:壓腳開關不聯動，縫製開始時下降
70	1~3	1	1	使用的腳踏控制器開關 1: 腳踏控制器開關(單踏) 2:雙連動腳踏控制器開關(可選) 3:三聯踏板
71	1~2	2	1	1：二級壓腳無效 2：二級壓腳有效
100	ON / OFF	OFF	-	慢速啟動模式的設定方法 ON:開啟 OFF:關閉
150	ON / OFF	OFF	-	倒縫針抬起 ON：上軸停止時電機逆轉，針杆返回到最上方的位置 [注意] 抬起倒縫針時，由於挑線杆會停止在比平時低的位置，因此開始縫紉的時候，挑線杆要上升。所以，各別縫紉條件下會出現脫針的情況。 OFF：無效
151	200~2800 (sti/min)	400	100	縫紉開始第1 針的速度
152	200~2800 (sti/min)	800	100	縫紉開始第2 針的速度

153	200~2800 (sti/min)	1200	100	縫紉開始第3 針的速度
154	200~2800 (sti/min)	1500	100	縫紉開始第4 針的速度
155	200~2800 (sti/min)	2000	100	縫紉開始第5 針的速度
156	400~2800 (sti/min)	2800	100	縫紉結束前5 針的速度
157	400~2800 (sti/min)	2800	100	縫紉結束前4 針的速度
158	400~2800 (sti/min)	2800	100	縫紉結束前3 針的速度
159	400~2800 (sti/min)	2400	100	縫紉結束前 2 針的速度
163	1200~3200 (sti/min)	2700	100	縫製速度限制值
164	ON / OFF	OFF	-	禁止剪線動作 ON:所有的剪線動作無效 OFF : 符合縫紉資料，進行剪線
260	-80~80	0	1	改變全部送布時間
261	-80~80	45	1	改變開始縫紉第 1 針的送布時間
262	-80~80	45	1	改變開始縫紉第 2 針的送布時間
263	-80~80	45	1	改變開始縫紉第 3 針的送布時間
264	-80~80	0	1	改變結束縫紉第 3 針的送布時間
265	-80~80	35	1	改變結束縫紉第 2 針的送布時間
266	-80~80	35	1	改變結束縫紉第 1 針的送布時間
268	0~2	1	1	改變全部送布時間基準
269	0~2	0	1	改變縫紉開始 3 針送布時間基準
462	0~3	0	1	擴大縮小的基準點 0:縫紉邊框的中心(原點) 1:縫紉開始點 2:圖案中心點 3:圖形左上點
471	1~17	14	1	壓腳/鈕扣夾的高度 (僅限電動壓腳)
472	1~17	6	1	兩段壓腳設定: 設置二級壓腳的高度,單位為mm。
500	ON/OFF	1	-	底線夾線功能設定 ON:有效

				OFF：無效
551	OFF/1~3	OFF	-	縫製開始麵線張力的打開 OFF:關閉 1~3：指定針數內打開
566	ON/OFF	OFF	-	底線夾線裝置是否安裝 ON：已安裝底線夾線裝置 OFF：未安裝底線夾線裝置 [注意] 安裝底線夾線裝置時，請勿選擇OFF。易造成裝置受損。
582	ON/OFF	OFF	-	縫製開始緊固麵線張力 ON:無效 OFF:有效
584	-110~40	0	5	縫製結束時，麵線張力打開角度偏移
585	0-500	255	1	縫製開始時的麵線張力值（緊固）
590	200~400	280	40	剪線速度 200~400sti/min單位（40sti/min） 初始預設值 280sti/min
592	200~700	400	100	主馬達最終速度
962	ON/OFF	OFF	-	斷線檢測 ON: 有效 OFF: 無效
963	0~1	0	1	0：手動張力器 1：電子張力器
964	ON/OFF	OFF	-	自動跑 ON:有效 OFF:無效
965	ON/OFF	OFF	-	手動夾線器起針打開 ON：有效 OFF：無效
966	0~2	2	1	撥線方式： 0：無效 1：電子式 2：氣動式。
991	1~9	8	1	慢啟動
992	0~1	0	1	移框方式 0：縫製完成後移動到起縫點

				1：縫製完成後移動到指定點
996	OFF/ON	OFF	-	氣動壓腳 OFF：電動壓腳 ON：氣動壓腳
997	0~2	0	1	0：左右壓腳同時下落 1：先左後右下落壓腳 2：先右後左下落壓腳 (氣閥壓腳為左右分壓腳且為雙踏板操作)
999	0~1	0	1	橡筋係數
1000	0~6	0	1	專用設備 0：無效 5：ready 信號
2001	0~1	0	1	6：自動 ready 信號 移動剛性

## 基本設置 2

### 1. 基本設置 2 介面

點擊基本設置 2 中的進入按鈕，進入到基本設置 2 介面，如圖所示。

### 2. 基本設置 2 功能說明

#### 1) 恢復超級設置密碼

如果忘記了自己設置的超級密碼，可以使用恢復超級設置密碼為預設密碼。使用這個功能需要從我們這裡獲得密碼，從而獲得恢復許可權。

#### 2) 時間日期設置

設置當前的日期和時間。

#### 3) 上位機參數設置

按上位機參數設置鍵進入上位機參數設置介面，如下圖所示。



(1) 提示音：ON：使用提示音，OFF：關閉提示音。

(2) 提示音使用默認音：ON：提示音使用統一默認音，OFF：提示音不使用統一默認音。

(3) 提示音類型：選擇默認提示音的類型。

(4) 針跡顯示：ON：打版中所有狀態下都顯示針跡點；OFF：打版中在對針跡點操作時才顯示針跡點。

(5) 音量：調節音量大小

(6) 開機介面針跡顏色

(7) 故障查詢：打開可查看錯誤資訊

(8) 特種機選擇

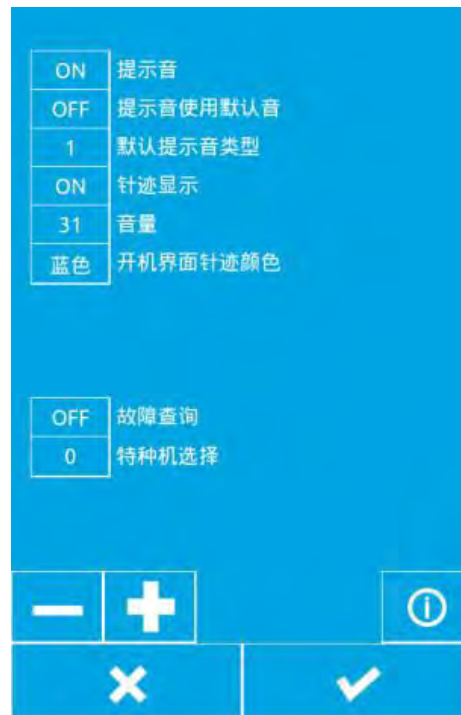

## 高級設置

### 高級設置介面

點擊密碼後面的空白處可以輸入密碼，輸入密碼後，點擊進入按鈕，進入到高級設置介面，如下圖所示，其中密碼設置按鈕可以更改進入高級設置的密碼，參數設置按鈕可以設置一些高級參數，上位機升級按鈕可以對面板程式進行升級，下位機升級按鈕可以對控制板程式進行升級，恢復出廠設置按鈕可以將程式的一些參數恢復到出廠時的設置，原點調整按鈕可以對原點位置進行調整。

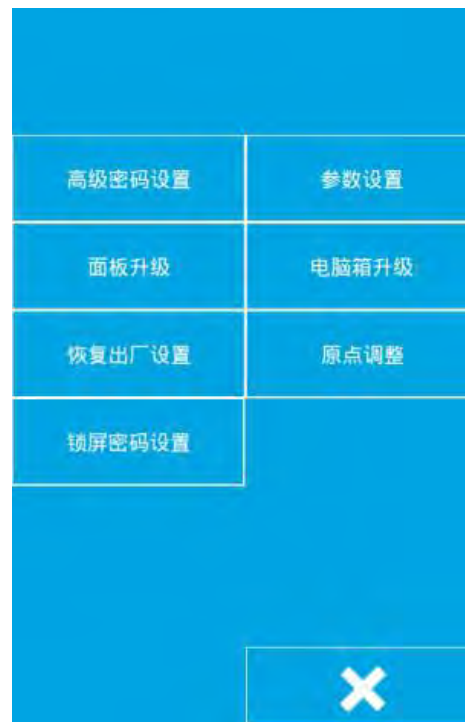

### 高級設置參數

點擊參數設置按鈕，可以進入高級參數設置介面，如圖所示。

- (1) 語言選擇：設置中英文。
- (2) 剪線角度調整：負值提前，正值是延時（-10到10）。
- (3) 斷線檢測針數：設置斷線檢測針數靈敏度。
- (4) 空送速度：設置空送速度等級（1-10），數值越大越快。

(5) 開機自動連線

ON:開電自動連線，進入花樣確認狀態

OFF:開電需要手動連線



## 上位機升級

本程式可以通過 U 盤對上位機（面板）進行升級，升級前需要將新版本程式 panel 檔和 am 資料夾一起複製到 U 盤主目錄，然後將 U 盤插入面板，然後通過參數設置--->高級設置-->上位機升級對面板程式進行升級，升級成功後會出現“成功，請重啟”提示，重啟即可。

## 下位機升級

本程式可以通過 U 盤對下位機（控制板）進行升級，升級前需要將新版本程式（630Q 機型 nc.bin 文件）（430Q/438Q 機型 STNC430.BIN 檔）複製到 U 盤主目錄，然後將 U 盤插入面板，然後通過參數設置--->高級設置--->下位機升級對控制板程式進行升級，升級成功後會出現“成功，請重啟”的提示，重啟即可。

## 恢復出廠設置

本程式通過恢復出廠設置功能可將基本設置 1 中的參數恢復預設值。

## 原點調整

點擊原點調整按鈕後進入原點調整介面如圖所示。

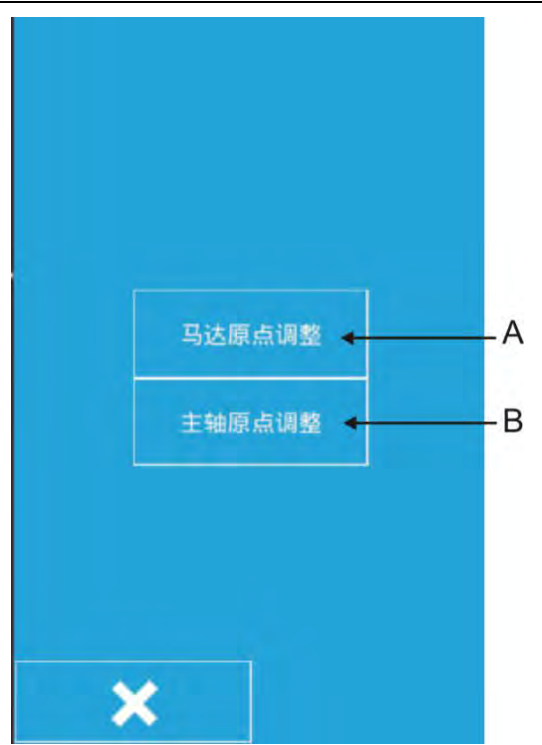



### 1.馬達原點調整

按 A 按鍵進入馬達原點調整介面，如圖所示，按下 1/2/3 按鈕（使按鍵處於按下狀態），按

按 、

鍵可調整 X/Y/Z 電機的原點位置，調整完成

後點擊 （被按下按鍵變為抬起狀態），

保存當前調整值，點擊  按鍵退出。



### 2.主軸原點調整

按 B 按鍵進入主軸原點調整介面，如圖所示。

C：當前主軸角度顯示值

（若顯示值為 65535 或-1 時，按手輪箭頭方向轉動主軸直至顯示值為 0~360 之間的數值）

D：機頭記憶體中存儲的停車角度值

主軸原點調整方法：按手輪箭頭方向轉動主軸顯示值為 0~360 之間的數值時，將針杆停在需要停止位置，按下 D 按鍵（使按鍵

處於按下狀態）後，按  按鍵保存當前

C 位置顯示的數值，即為主軸停車位置，按  鍵退出。

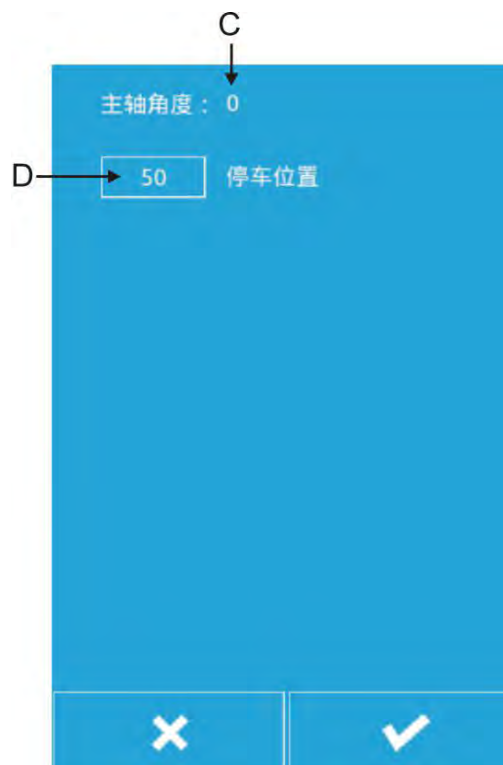

## 超級設置



## 協助工具

按協助工具鍵進入協助工具介面，如圖所示。



## 範本 ID

這個功能是用來定義範本的，範本上個有無線識別卡。每一個卡都有一個 ID 號，這個 ID 號與面板中的 P 花樣號對應。當新做了一塊無線識別卡範本或者更改範本 ID 時，將無線識別卡放到範本感應器上，然後在協助工具介面的範本 ID 編輯方塊中輸入範本 ID 號，輸入完成後點擊“寫入”按鈕，即可將範本 ID 號寫入無線識別卡，寫入完成會提示成功。

## 更改啟動圖片

如果想更改面板啟動時候顯示的圖片，可以將需要顯示的圖片發給我們，然後我們將圖片更改為指定格式的檔再發送給您，您將這個修改後的圖片檔放到 U 盤中，將 U 盤插到面板上，就可以點擊“更改”按鈕更改啟動圖片，更改完成會提示成功。

## 內核升級

當需要對內核進行升級的時候，我們會提供 conprog.bin 檔給您，您將這個檔放入 U 盤，將 U 盤插到面板上，待面板識別 U 盤完成後，就可以點擊“內核升級”按鈕進行升級，升級完成後會提示升級成功。

## 提示音升級

當需要對按鍵提示音進行升級的時候，我們會提供 wxaudio 資料夾給您，您將這個資料夾放入 U 盤，將 U 盤插到面板上，待面板識別 U 盤完成後，就可以點擊“提示音升級”按鈕進行升級，升級完成後會提示升級成功。

---

## 計數器

按計數器鍵進入計數器介面，如右圖所示。  
可以設置縫製計數器和針數計數器的模式，  
可以設置計數器當前值和最大值。

加计数器	0	1000
缝制计数器模式	当前值	最大值
减计数器	10000	10000
针数计数器模式	当前值	最大值

## 關於

按關於鍵進入版權資訊查詢介面，輸入密碼可以查看版權資訊。

## 9 附錄 1 誤碼表

萬一機器發生故障時，操作面板會顯示錯誤代碼。

請按照下表的處理方法來排除故障。

錯誤代碼	描述
10	摠了緊急停止開關。摠RESET鍵，消除錯誤。
11	摠暫停開關。摠RESET鍵，消除錯誤。摠該鍵後移動壓腳，可以繼續縫紉。
12	摠暫停開關。摠RESET鍵消除錯誤後，將腳踏板踩到第2檔，進行原點檢驗。
15	電源接入時摠了緊急停止開關，但是緊急停止開關接觸不良。切斷電源，確認主機板插座P9的插頭。
16	電源接入時緊急停止開關接觸不良。切斷電源，確認主機板插座P9的插頭。
25	電源接入時，腳踏板開關被踩到第2檔的位置。（2腳踏板開關時，是起動開關）切斷電源，確認腳踏板開關。
35	電源接入時腳踏板開關被踩到第1檔的位置。（2腳踏板開關時，是壓緊開關）切斷電源，確認腳踏板開關。
50	電源接入後，發現縫紉機頭傾倒。切斷電源，扶起縫紉機頭。確認主機板插座P14的插頭。
51	縫紉機啟動過程中發現縫紉機頭傾倒。切斷電源，確認主機板插座P14的插頭。
55	電源接入時，發現縫紉機頭傾倒。切斷電源，扶起縫紉機頭。切斷電源，確認主機板插座P14的插頭。
65	電源接入時，操作面板的鍵是摠下的狀態，或者鍵的接觸不良。切斷電源，確認操作面板鍵。
100	“GREASEUP”通知出現後，若不添加潤滑脂（不進行清除工作的操作）。添加潤滑，然後執行清除工作的操作。
111	停車位置不正確---切斷電源，確認剪線裝置或者縫紉機電機是否出現異常現象。
121	剪線無法完成。切斷電源，確認固定刀、移動刀的刀刃部分是否出現刮痕或受損。
130	主馬達故障---主軸電機故障，或主軸電機控制器故障。
131	同步顯示器接觸不良。切斷電源，確認電機主機板插盤P11的插頭狀況是否良好。
132	發現縫紉機主馬達非正常旋轉切斷電源，確認電機主機板插盤P11的插頭狀況是否良好。
133	縫紉主馬達停止位置不良。切斷電源，確認電機主機板插盤P11的插頭狀況是否良好。
150	縫紉機主馬達非正常升溫或者溫度感測器運轉不良。切斷電源，確認縫紉機電機狀況。（如果反復進行短運針數（15針一下）的縫紉資料縫紉（短週期），上軸電機過熱，就有發生[E150]故障的可能。）
200	X方向找不到原點---X電機故障，或Y原點感測器故障
201	X脈衝馬達非正常停止。切斷電源，確認X送布方向是否存在異常現象。
203	X電機過電流---X電機故障，或X電機控制板故障
204	縫紉過程中，X脈衝馬達非正常停止。切斷電源，確認X送布方向是否存在異常現象。
205	向縫紉開始位置移動過程中，X脈衝馬達非正常停止。切斷電源，確認X送布方向是否存在異常現象。
206	檢驗傳送過程中，X脈衝馬達非正常停止。切斷電源，確認X送布方向是否存在異常

207	無法檢測到X電機運動---Y電機故障，或X電機編碼器故障，或X電機控制板故障
208	X電機失控---X電機編碼器故障，或X電機控制板故障
210	Y方向找不到原點---Y電機故障，或Y原點感測器故障
211	Y脈衝馬達非正常停止。切斷電源，確認Y送布方向是否存在異常現象。
213	Y電機過電流---Y電機故障，或Y電機控制板故障
214	縫紉過程中，Y脈衝馬達非正常停止。切斷電源，確認Y送布方向是否存在異常現象。
215	向縫紉開始位置移動過程中，Y脈衝馬達非正常停止。切斷電源，確認Y送布方向是否存在異常現象。
216	檢驗傳送過程中，Y脈衝馬達非正常停止。切斷電源，確認Y送布方向是否存在異常現象。
217	無法檢測到Y電機運動---Y電機故障，或Y電機編碼器故障，或Y電機控制板故障
218	Y電機失控---Y電機編碼器故障，或Y電機控制板故障
300	剪線電機找不到原點---剪線電機故障，或剪線電機編碼器故障
301	無法檢測壓腳／鈕扣夾的上升、下降。切斷電源，確認壓腳／鈕扣夾的上下方向是否存在異常現象。
303	剪線電機過電流---剪線電機故障，或剪線電機控制板故障
307	無法檢測到剪線電機電運動---剪線電機故障，或剪線電機編碼器故障，或剪線電機控制板故障
308	剪線電機失控---剪線電機編碼器故障，或剪線電機控制板故障
320	抓線電機找不到原點---抓線電機故障，或抓線電機編碼器故障
321	抓線電機過電流---抓線電機故障，或抓線電機控制板故障
323	無法檢測到抓線電機電運動---抓線電機故障，或抓線電機編碼器故障，或抓線電機控制板故障
324	抓線電機失控---抓線電機編碼器故障，或抓線電機控制板故障
400	電源接入時，檢測出主機板和控電板主機板之間的連結通信錯誤。切斷電源，確認控電板主機板的插座P1和電機主機板的插座P3的插頭狀況是否良好。
401	電源接入時，檢測出主機板和電機主機板之間的連結通信錯誤。切斷電源，確認主機板的插座P5和電機主機板的插座P2的插頭狀況是否良好。
410	檢測出主機板和控電板主機板之間的通信錯誤。切斷電源，再次接入電源。
411	檢測出主機板和電機主機板之間存在通信錯誤。切斷電源，再次接入電源。
420	未插入存儲工具。摁RESET鍵，排除錯誤。
421	由於資料內容不正確無法使用，或者無數據。摁RESET鍵，排除錯誤。確認存儲工具中是否存入該式樣序號的資料。
422	讀取存儲工具資訊時發生錯誤。摁RESET鍵，排除錯誤。確認存儲工具內的資料。
424	存儲工具內空間不足。摁RESET鍵，排除錯誤。使用其他存儲工具。
425	寫入存儲工具時發生錯誤。摁RESET鍵，排除錯誤。請使用指定存儲工具。確認是否是禁止寫入，或者是否有空間。
427	註冊在迴圈程式中的式樣被刪除。摁RESET鍵，排除錯誤。重新註冊迴圈程式，添加式樣。
428	設定在程式中的式樣被刪除。摁RESET鍵，排除錯誤。重新設定程式，添加花樣。
430	資料無法備份到主機板。切斷電源，並重新接入電源。

440	主機板資料存儲異常。切斷電源，並重新接入電源。
450	無法從機頭部存放裝置讀取機種選擇資訊。切斷電源，確認電源電機主機板的插排P16的插頭狀況是否良好。
451	不能將資料存儲到機頭記憶體中。切斷電源，並重新接入電源。
452	無法連接到機頭部存放裝置。切斷電源，確認主機板的插排P16的插頭狀況是否良好。
480	範本位置感應器異常
500	做擴大設定之後，縫紉資料超過可以縫紉的區域。摠RESET鍵，排除錯誤。再次設定擴大倍率或者縫紉區域。
502	做擴大設定之後，資料螺距超過最大螺距12.7mm。摠RESET鍵，排除錯誤。再次設定擴大倍率。
510	程式資料出現異常。摠RESET鍵，排除錯誤。從存儲工具中重新讀取程式資料，或者重新輸程式資料。
511	完成代碼無法輸入到程式資料中。摠RESET鍵，排除錯誤。重做輸入完成代碼的程序數據，或者變更讀取程式的序號。
512	超過可以使用的針數。摠RESET鍵，排除錯誤。變更讀取程式的序號。
581	無法正確讀取存儲開關資料夾。複製前機種和複製後機種不正確。(438Q的數據有讀取到430Q的可能性)摠RESET鍵，排除錯誤。請讀取同一機種的資料。
582	存儲開關的版本不一致。摠RESET鍵，排除錯誤。請讀取同一版本的資料。
583	參數的版本不一致。摠RESET鍵，排除錯誤。請讀取同一版本的資料。
600	發生麵線斷裂。摠RESET鍵，排除錯誤。摠KEY_STEP_BACK鍵後移動壓腳，可以繼續縫紉。
690	中壓腳電機找不到原點---中壓腳電機故障，或中壓腳電機編碼器故障
691	底線夾線馬達非正常停止。確認是否麵線餘量過長。切斷電源，清除針板底部的飛絨。確認主機板基板的插座P20、P4的插頭狀況是否良好。
693	中壓腳電機過電流---中壓腳電機故障，或中壓腳電機控制板故障
697	無法檢測到中壓腳電機電運動---中壓腳電機故障，或中壓腳電機編碼器故障，或中壓腳電機控制板故障
698	中壓腳電機失控---中壓腳電機編碼器故障，或中壓腳電機控制板故障
700	電源電壓異常上升。切斷電源，確認輸入電壓。
701	縫紉機主馬達驅動電壓異常上升。切斷電源，確認電壓
705	電源電壓異常下降。切斷電源，確認輸入電壓。
710	縫紉主馬達檢出異常電流。切斷電源，確認縫紉機是否出現異常。
711	脈衝電機檢出異常電流。切斷電源，確認壓腳/鈕扣夾的運轉是否出現異常。
720	機頭無法下降
721	機頭無法上升
820	花樣佇列空
821	花樣無結束碼
822	花樣無停車碼

---

830	花樣數據溢出
850	CAN匯流排應答錯誤
901	X電機脈衝錯誤（內部錯誤）
902	Y電機脈衝錯誤（內部錯誤）
903	剪線電機脈衝錯誤（內部錯誤）
904	中壓腳電機脈衝錯誤（內部錯誤）
905	抓線電機脈衝錯誤（內部錯誤）
906	內部錯誤
911	內部錯誤
912	內部錯誤
913	內部錯誤
914	內部錯誤

---





# Foreword

Welcome to use our special sewing machine control system. Please read this operating manual carefully to ensure proper operation and use of special sewing machines, Please follow the instructions in this manual. Otherwise, the company will not be liable for any losses caused by illegal operation. In addition, keep this user manual in a safe place for easy access. In the event of failure, repairs must be performed by a technician or professional designated by the company.







# Safety Precautions





## 1. Signs and meanings of safe operation

















The safety signs used in this instruction manual and the product are designed to allow you to use the product correctly and safely to prevent injury to you and others. The pattern and meaning of the logo are as follows:

 危険	If you ignore this mark and perform the wrong operation, it may result in serious injury or death.
 注意	If you ignore this mark and perform the wrong operation, it may result in personal injury and equipment damage.
	This symbol indicates "should be noted". The pattern in the triangle indicates what must be noted. (For example, the pattern on the left indicates: "Beware of injury")
	This symbol means "prohibited"
	This symbol indicates "must". The pattern in the circle indicates what must be done. (For example, the pattern on the left indicates "must be grounded")

## 2. Safety precautions

 危険	
	When opening the control box, turn off the power switch and unplug the power plug from the outlet. Wait at least 5 minutes before opening the control box cover. Touching an area with a high voltage can cause personal injury.
 注意	
<b>Using environment</b>	
	Avoid using the sewing machine near strong electrical interference sources such as high frequency welders. Strong electrical interference sources may affect the normal operation of the sewing machine.
	The fluctuation of the power supply voltage should be used within $\pm 20\%$ of the rated voltage. Large fluctuations in voltage can affect the normal operation of the sewing machine and require a voltage regulator.
	The ambient temperature should be used in the range of $5^{\circ}\text{C} \sim 35^{\circ}\text{C}$ . Low temperatures or high temperatures can affect the normal operation of

	the sewing machine.
	The relative humidity should be in the range of 45% to 85%, and the device should not be used in the environment where condensation does not form. Dry, wet or dew condensation can affect the proper operation of the sewing machine.
	The compressed air supply should be greater than the total gas consumption required by the sewing machine. The insufficient supply of compressed air will lead to abnormal operation of the sewing machine.
	In case of lightning storm, turn off the power switch and unplug the power plug from the socket. Lightning may affect the correct operation of sewing machines.
<b>install</b>	
	Please let the trained technician install the sewing machine.
	Please do not connect to the power supply until the installation is complete. If you press the start switch by mistake, the sewing machine will cause injury.

	When the sewing machine head falls or rises, please operate with both hands. Don't press the sewing machine hard. If the sewing machine is out of balance, the slippage of the sewing machine to the ground will cause injury or damage to the machine.
	It must be ground. The ground wire is not firm, which is the cause of electric shock or wrong action.
	All cables should be fixed at least outside the 25mm of the movable parts. In addition, do not bend too much or fasten it too tightly with pins. The risk of fire or electric shock.
	Please install the safety case on the machine head.
<b>sewing</b>	
	This sewing machine is limited to personnel trained in safe operation.
	This sewing machine cannot be used for any purpose other than sewing.
	Protective glasses must be worn when using sewing machines. If you do not wear protective glasses, the broken part of the needle may pop into the eye and cause injury when the needle is broken.
	Please cut off the power supply immediately when the following conditions occur. Otherwise, when the switch is pressed by mistake, it will cause injury. 1. When the needle is pierced, 2. When changing the needle, 3. When the sewing machine is not in use or when a person leaves the sewing machine
	Do not touch any moving parts or lean them against them during sewing, as this can cause injury or damage to the sewing machine.
	If there is a mistake in the operation of the sewing machine, or if you hear abnormal noise or smell abnormal smell, you should immediately turn off the power supply. Then contact the purchase store or trained technician.
	If the sewing machine fails, please contact the purchasing store or trained technician.
<b>Maintenance and inspection</b>	
	Only trained technicians can repair, maintain and inspect sewing machines.
	Please contact the professionals of electronic control manufacturer in time for electrical repair, maintenance and inspection.
	Turn off the power and unplug the power when the following occurs. Otherwise, when the switch is pressed by mistake, it will cause injury. 1. Inspection, adjustment and maintenance 2. Replacement of vulnerable parts such as needles, cutters, etc.
	Before checking, adjusting, and repairing any pneumatic equipment, please disconnect the gas source and wait for the gauge pointer to drop to "0".
	Be careful to follow all safety considerations when you have to connect the power switch and the gas source switch to adjust.

	Damage to sewing machine caused by unauthorized modification of sewing machine is not covered by warranty.
---	--

## catalogue

1.1 summary.....	1
1.2 Technical parameter table.....	1
1.3 List of sewing patterns(430Q).....	2
1.4 List of sewing patterns(438Q).....	8
1.5 Sewing pattern list (630Q).....	11
1.6 Matters needing attention in safe use.....	16
● Task environment.....	16
● installation.....	16
● Maintenance, inspection and repair.....	17
● Other security countermeasures.....	17
● Waste disposal.....	17
● Warning signs and danger signs.....	17
1.7 Precautions for use.....	19
1.8 Standardization.....	21
1.9 Mode of operation.....	21
2 Instructions.....	22
2.1 Universal button.....	22
2.2 Basic operation.....	23
2.3 Ordinary pattern operation.....	23
Function Description:.....	24
Function Description:.....	25
2.4 Pattern registration.....	26
2.5 Pattern naming.....	27
2.6 Winding.....	28
2.7 Threading.....	29
2.8 Pattern selection.....	30
2.9 Sewing data setting.....	32
2.10 P pattern registration.....	34
2.11 Trial operation.....	36
2.12 Counter operation.....	37
2.13 Adjust the stitching point operation.....	40
2.14 Emergency stop.....	41
3 Fast (P) pattern operation.....	42
3.1 P pattern data input.....	42
Function Description: .....	42
3.2 P Pattern Editing.....	44
3.3 P Pattern paste.....	46

---

3.4 P Pattern sewing.....	47
Function Description: .....	47
4 Combination (C) pattern operation.....	50
4.1 C Pattern data input.....	50
4.2 C pattern editing.....	52
4.3 C pattern selection.....	54
4.4 C pattern sewing.....	55
Function Description: .....	55
5 Pattern editing.....	57
5.1 Enter the pattern editing mode.....	57
Function Description: .....	58
5.2 Pattern Edition.....	61
5.3 Pattern modification.....	65
5.4 Exit pattern editing mode.....	68
6 Information function.....	69
6.1 View version information.....	69
7.1 About data that can be processed.....	70
7.2 Pattern transmission.....	70
8 Mode and parameter settings.....	75
8.1 Mode switching.....	75
Three modes: normal seam mode, pattern pattern, and loop stitch mode.....	75
Sewing Mode.....	75
Design Pattern Mode.....	75
Circle Sewing Mode.....	75
8.2 Test.....	76
8.2.1 Input test.....	76
8.2.2 Action test.....	77
8.2.3 Output test.....	78
8.2.4 External output test.....	78
8.2.5 Spindle angle test.....	79
8.2.6 Simulate pedal calibration.....	79
8.3 parameter settings.....	80
8.3.1 Basic setting 1.....	81
8.3.2 Basic setting 2.....	86
8.3.4 Super setting.....	90
8.4 Accessibility.....	91
8.4.1. Template ID.....	91
8.4.2. Change startup image.....	91
8.4.3. Kernel upgrade.....	91
8.4.4. Tone tone upgrade.....	92
8.5 counter.....	92
8.6 Regarding.....	92
9. Appendix 1 Error Table.....	93

# 1 Summary description

## 1.1 summary

This series of industrial sewing machine computer control system, spindle motor with the world advanced level of AC servo control technology to drive, with the characteristics of large torque, high efficiency, stable speed and low noise. The diversified design of the operation panel can meet the matching requirements of different customers; the system adopts German structure design, the installation and maintenance are convenient and fast, and the system control software can be upgraded through remote communication to facilitate users to continuously improve the performance of the product.

## 1.2 Technical parameter table

	430Q Direct driving computer flat seam knotting machine	438Q Direct driving computer flat seam nail fastening machine
Trace form	Single needle flat seam	
Maximum sewing speed	3,200 sti/min	2,700 sti/min
Size(X×Y)	maximum 40×30 mm	maximum 6.4×6.4 mm
Size of sewing button		Button outer diameter 8~30mm(※1)
Delivery drive mode	Y-θ Intermittent feeding (pulse motor drive)	
Needle gage	0.05~12.7mm	0.05~6.4mm
Number of needles	Please refer to the Sewing pattern list for the number of sewing stitches you have entered.	
Maximum number of needles	About 5000 needles (pattern 1)	
Lifting foot drive mode	Pulse motor drive	
Pressure foot lift button clip rise amount	maximum 17mm	maximum 13mm
Shuttle hook used	Standard semi-rotating shuttle (double spinning shuttle sold separately)	Standard semi-rotating shuttle
Digital tensioner	standard facility	
Wire sweeper	standard facility	
Tangent device	standard facility	
Trapper	Specifications: options	option
Data storage mode	Quick erase memory (any sewing pattern can be added to the U disk)	
Data carrier	U disk (≤ 2)	
Number of cyclic	Up to 30 registrations (up to 50 steps per step)	

programs		
Number of stored data	89 sewing patterns have been set	64 sewing patterns have been set
	(up to 799 additional sewing pattern types. The total number of additional needles is 500000.) ( $\leq 3$ )	
Motor	AC servo motor 550W	
Weight	Head: about 57 kg, operating panel: about 0.4kg control box: 9kg	
Power	Single phase 220 V, 3 phase 380 V (for three phase 380 V, need to use transformer.)2502B 2278 B	

※1When the outer diameter is above 20mm, please use the optional button clip assembly B (S03634 / 101)。

※2 There is no guarantee of operational problems caused by the use of any media。













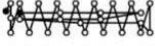

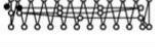
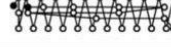

※3 The number and number of stitches that can be recorded will depend on the number of needles per sewing pattern. 。

### 1.3List of sewing patterns(430Q).

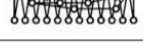
The sewing patterns shown below are pre-set and can be selected according to the specifications. (As long as it can be confirmed that it is within the working range of the presser foot and the feed plate, you can choose to use any sewing pattern.)

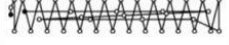
Use a presser foot and a feed plate that meet the requirements of various sewing patterns.



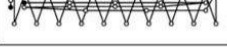
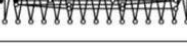
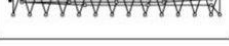
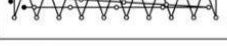





The length of sewing when the size is 100% scaling.

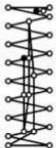

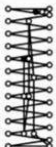

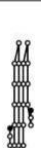
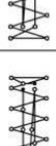

适用于一般重量的布料 (-03)									
号码	花样	针数	尺寸 (mm)		号码	花样	针数	尺寸 (mm)	
			长度	宽度				长度	宽度
1		42	16	2	65		43	16	2
4		31	16	2	66		32	16	2
5		29	10	2	67		30	10	2
8		21	7	2	68		22	7	2
13		35	10	2	69		36	10	2
15		42	10	2	70		43	10	2
20		28	7	2	71		29	7	2
21		35	7	2	72		36	7	2
64		30	16	2	89		90	24	3
适用于厚重的布料 (-05)									
号码	花样	针数	尺寸 (mm)		号码	花样	针数	尺寸 (mm)	
			长度	宽度				长度	宽度
2		42	20	3	18		56	24	3
3		35	20	3	19		64	24	3
6		30	16	3	62		42	20	3
14		35	16	3	63		35	20	3
16		43	16	3	78		43	20	3
17		42	24	3	79		36	20	3
适用于厚重的布料 (-05)									

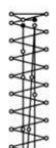
号码	花样	针数	尺寸 (mm)		号码	花样	针数	尺寸 (mm)	
			长度	宽度				长度	宽度
80		31	16	3	83		43	24	3
81		36	16	3	84		57	24	3
82		44	16	3	85		65	24	3
适用于针织布料 (-OK) 和女性内衣 (-OF)									
号码	花样	针数	尺寸 (mm)		号码	花样	针数	尺寸 (mm)	
			长度	宽度				长度	宽度
7		28	8	2	73		29	8	2
9		21	7	2	74		22	7	2
22		14	7	2	75		15	7	2
31*		28	8	2	76*		29	8	2
32*		22	8	2	77*		23	8	2
33*		15	8	2					

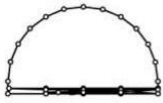

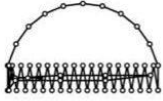

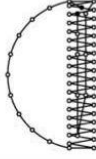

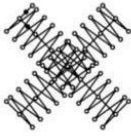
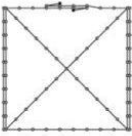
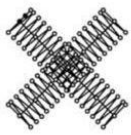
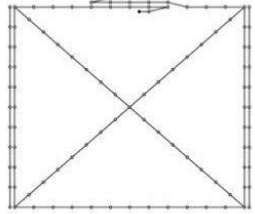

\* 始针和终结针的位置在图案的中间。

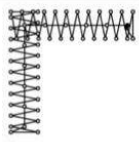
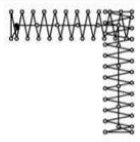
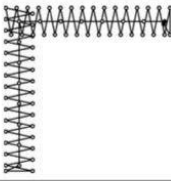
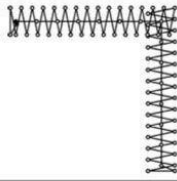
直线结					垂直曲折缝				
号码	花样	针数	尺寸 (mm)		号码	花样	针数	尺寸 (mm)	
			长度	宽度				长度	宽度
10		21	10	0.3	44		46	9	15
11		28	10	0.3					
12		28	20	0.3	45		70	9	25
23		35	25	0.3					
24		42	25	0.3					
25		45	25	0.3					

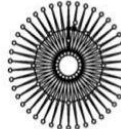
垂直结					垂直直线结				
号码	花样	针数	尺寸 (mm)		号码	花样	针数	尺寸 (mm)	
			长度	宽度				长度	宽度
26		28	3	10	28		19	0.3	10
27		35	3	10	29		21	0.3	10
40		32	3	16	30		28	0.3	10
41		36	3	16	46		27	0.3	20
42		44	3	20	47		44	0.3	25
43		68	3	24					

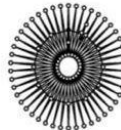
月牙结									
号码	花样	针数	尺寸 (mm)		号码	花样	针数	尺寸 (mm)	
			长度	宽度				长度	宽度
34		35	12	7	37		57	7	12
35		58	12	7	38		53	7	10
36		57	7	12	39		53	7	10

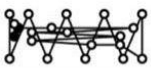
X 形结					交叉结				
号码	花样	针数	尺寸 (mm)		号码	花样	针数	尺寸 (mm)	
			长度	宽度				长度	宽度
48		70	10	10	50		84	16	16
49		93	9.6	9.6	51		105	30	26

L形结									
号码	花样	针数	尺寸 (mm)		号码	花样	针数	尺寸 (mm)	
			长度	宽度				长度	宽度
52		60	11.3	11.2	53		60	11.3	11.2
54		78	15.3	15.2	55		78	15.3	15.2
菊形缝									
号码	花样	针数	尺寸 (mm)		号码	花样	针数	尺寸 (mm)	
			长度	宽度				长度	宽度
56		106	9	9	59		104	10	10
57		116	9	9	60		114	10	10
58		127	9	9	61		124	10	10
圆眼钮孔									
号码	花样	针数	尺寸 (mm)						
			长度	宽度					
86		21	6	2					
87		28	6	2					
88		35	6	2					





如果想缝纫标准花样以外的其他缝纫花样，可以使用 PS-300B 创建原始花样。详情请咨询当地的兄弟销售办事处。

**创建附加缝纫花样时请注意**

如果反复缝纫（短循环运转）运针数（15 针以下）短的缝纫数据，则可能会引起上轴马达过热错误 [E150] 的现象。

## 1.4 List of sewing patterns(438Q).

The sewing pattern shown below has been set in advance. As long as the needle can pass through the buttonhole, any sewing pattern can be selected. For sewing patterns without overlock stitches, trim the thread after sewing on one side and then stitch the other side.

号码	组孔数	花样	线数	包缝数	针数	尺寸 (mm)				
						X	Y			
1	2		6	—	12	3.4	0			
※1 54			6	—	12					
2			8	—	14					
※1 55			8	—	14					
3			10	—	16					
4			12	—	18					
※2 5			16	—	22					
※2 6			20	—	26					
※1 56				6	—			11	0	3.4
※3 7				6	—			12		
※3 23	10	—		16						
※3 8	12	—		18						
※3 9	3		5-5-5	—	21	2.6	2.4			
※3 24			7-7-7	—	27					
※3 25			5-5-5	—	21					
※3 26			7-7-7	—	27					
※1 57	4		6-6	1	18	3.4	3.4			
10			6-6	1	19					
※1 58			8-8	1	22					
11			8-8	1	23					
12			8-8	3	25					
13			10-10	1	27					
27			12-12	1	31					

※1 用于小孔纽扣。

※2 使用程序前，请检查组孔直径不小于 2mm。



※3 不可使用钮扣抬起弹簧。

号码	组孔数	花样	线数	包缝数	针数	尺寸 (mm)	
						X	Y
14 ※4	4		6-6	0	24	3.4	3.4
36 ※5			6-6	0	24		
28 ※4			8-8	0	28		
37 ※5			8-8	0	28		
15 ※4			10-10	0	32		
38 ※5			10-10	0	32		
29 ※4			12-12	0	36		
39 ※5			12-12	0	36		
59 ※1				6-5	1		
16		6-5		1	18		
60 ※1		8-7		1	21		
17		8-7		1	22		
30		10-9		1	26		
61 ※1				6-6	1		
18			6-6	1	19		
62 ※1			8-8	1	22		
19			8-8	1	23		
63 ※1			10-10	1	26		
31			10-10	1	27		
45			12-12	1	31		
20 ※4			6-6	0	24		
40 ※5			6-6	0	24		
32 ※4			8-8	0	28		
41 ※5			8-8	0	28		
33 ※4	10-10		0	32			
42 ※5	10-10		0	32			

※1 用于小孔纽扣。

※4 在完成一边缝纫后，钮扣夹就上升并进行拔线动作。为了将缝纫进行到底，在另一边的缝纫开始之前，请继续踩下脚踩开关；或在完成一边缝纫后，请再次踩下脚踩开关。

※5 在完成一边缝纫后，钮扣夹不上升而只进行拔线动作，并继续进行另一边的缝纫。

号码	纽孔数	花样	线数	包缝数	针数	尺寸 (mm)	
						X	Y
※1 64	4		6-6	1	18	3.4	3.4
※3 21			6-6	1	19	2.4	
※3 34			10-10	1	27		
※3※4 22			6-6	0	24		
※3※5 43			6-6	0	24		
※3※4 35			10-10	0	32		
※3※5 44			10-10	0	32		
46			6-7	1	19	3.4	3.4
47			8-9	1	23		
48			10-11	1	27		
49			12-13	1	31		

※1 用于小孔纽扣。

※3 不可使用纽扣抬起弹簧。

※4 在完成一边缝纫后，纽扣夹就上升并进行拔线动作。为了将缝纫进行到底，在另一边的缝纫开始之前，请继续踩下脚踩开关；或在完成一边缝纫后，请再次踩下脚踩开关。

※5 在完成一边缝纫后，纽扣夹不上升而只进行拔线动作，并继续进行另一边的缝纫。

用于带柄纽扣					
号码	花样	线数	针数	尺寸 (mm)	
				X	Y
50		6	12	3.4	0
51		8	14		
52		10	16		
53		12	18		

**创建附加缝纫花样时请注意**

如果反复缝纫（短循环运转）运针数（15 针以下）短的缝纫数据，则可能会引起上轴马达过热错误 [E150] 的现象。











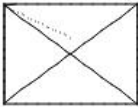
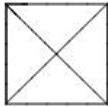

### 1.5 Sewing pattern list (630Q)

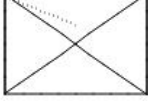



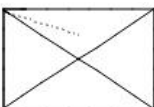
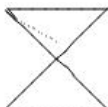

The sewing patterns shown below are pre-set and can be selected according to the specifications. (As long as it can be confirmed that it is within the working range of the presser foot and the feed plate, you can choose to use any sewing pattern.)

Use a presser foot and a feed plate that meet the requirements of various sewing patterns.

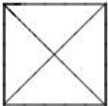
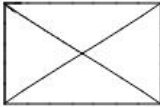
The length when the sewing size is 100%.

No.	落针图	针数	缝纫尺寸		No.	落针图	针数	缝纫尺寸	
			mm					Mm	
			纵	横				纵	横
1		54	30	40	9		38	20	20
2		46	30	30	10		38	20	20
3		113	20.1	38.4	11		33	18	18
4		97	20	28.8	12		33	18	18
5		81	20	19	13		30	18	18
6		52	11	9.4	14		30	13	18
7		48	25	25	15		39	25	35

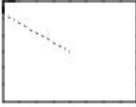
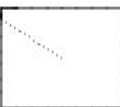
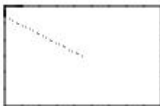
8		48	25	25	16		108	30	40
No.	落针图	针数	缝纫尺寸 mm		No.	落针图	针数	缝纫尺寸 mm	
			纵	横				纵	横
17		96	30	40	25		52	20	20
18		84	30	40	26		42	30	40
19		66	25	35.1	27		38	25	35
20		62	25	30	28		36	25	30
21		56	20	30	29		46	28	28
22		68	28	28	30		36	20	25
23		66	20	28	31		36	20	25

24		62	20	25	32		50	15	15
No.	落针图	针数	缝纫尺寸 mm		No.	落针图	针数	缝纫尺寸 mm	
			纵	横				纵	横
33		56	16	25	41		48	20	40
34		65	30	35	42		33	27. 2	37.1
35		30	15	15					
36		34	18	24					
37		36	20	24					
38		36	16	25					
39		42	25	25					

<b>40</b>		<b>42</b>	<b>25</b>	<b>35</b>					
-----------	---	-----------	-----------	-----------	--	--	--	--	--

	机 型 项 目	<b>630Q small pattern sewing machine</b>
<b>1</b>	Trace form	Single needle flat seam
<b>2</b>	Maximum sewing speed	2,700rpm
<b>3</b>	Sewing size (X × Y)	maximum: 80×60mm;
<b>4</b>	Delivery drive mode	Intermittent feeding (pulse motor drive)
<b>5</b>	Needle gage	0.05-12.7mm
<b>6</b>	Number of needles	Memory 500000 pins
<b>7</b>	Maximum number of needles	20000 needles (1 procedure)
<b>8</b>	Store data that may be sewing	Memory: 999. U disk: unlimited
<b>9</b>	Lifting foot drive mode	Electromagnetic specification: pulse motor drive, air pressure specification: air pressure type
<b>10</b>	Foot lift	Electromagnetic specification: maximum 17 mm, air pressure specification: maximum 17mm
<b>11</b>	2 stage foot pressing	Left and right integrated foot pressing
<b>12</b>	Intermittent foot rise	22mm
<b>13</b>	Intermittent foot pressing stroke	$2 \leq 4.5 \text{ mm}$ , $4.5 \times 10 \text{ mm}$ or 0 (3mm when leaving the factory)
<b>14</b>	Shuttle hook used	Semi-rotating twice rotating shuttle (standard shuttle bought separately)
<b>15</b>	Wire buckle device	standard facility
<b>16</b>	Tangent device	standard facility
<b>17</b>	Data storage mode	Memory (quick erase memory), U disk
<b>18</b>	Number of user programs	50

<b>19</b>	Number of cyclic programs	9
<b>20</b>	Motor	AC servo motor 550W.
<b>21</b>	Weight	Head: about 88 kg, operating disk: about 0.6kg Control box: 14.2-16.2kg (depending on voltage)
<b>22</b>	Power	单相 100V/220V、3 相 200V/220V/380V/400V 400VA
<b>23</b>	Air pressure	0.5Mpa 1.81/min

※The maximum sewing speed should be reduced according to the sewing conditions.

---

## 1.6 Matters needing attention in safe use

### ● Task environment

Please do not use this control device in the following environments:

- supply voltage
  - ◆ The change of voltage will exceed the fixed voltage of  $\pm 10\%$  of the place.
  - ◆ The power supply capacity cannot be guaranteed in the place of the specified capacity.
- interference of waves
- Next to it are radio emitters and high-cycle machines that emit strong radio waves and magnetic fields.
  - ◆ The place where the room temperature is between 0 °C and 50 °C.
  - ◆ A place where outdoor or sunlight shines directly.
  - ◆ The place next to the heater(electric heater).
  - ◆ A place where the relative humidity is between 5% and 95% (no condensation).
- Air
  - ◆ A place of corrosion or dust.
  - ◆ Places prone to gas or oil explosion.
- vibrate
  - ◆ If the place where the sewing machine is placed is prone to excessive vibration, place the control box elsewhere.

### ● installation

- control box
  - ◆ Please follow the instructions and install it correctly.
- appendix
  - ◆ If you want to install other accessories, please turn off the power supply and unplug the power supply.
- power line
  - ◆ Please do not use gravity to suppress the power cord or excessive distortion of the power cord.
  - ◆ Please do not put the power cord near the rotating part, at least leave the 25mm above.
  - ◆ Before the control box is connected to the power supply, please check whether the power supply voltage to be connected is the same as the voltage marked on the control box and determine the position before you can supply the power supply. If there is a power transformer, the same must be checked before the power supply can be supplied. At this time, the button power switch on the sewing machine must be placed in [OFF].
- landing

- ◆ In order to prevent electric shock events caused by noise interference and leakage, the grounding line on the power cord must be sure to do a good job of grounding.
- fixture
  - ◆ If you want to connect to the electrical accessories, please follow the instructions.
- dismantle
  - ◆ To remove the control box, you must first turn off the power supply and unplug the power supply.
  - ◆ When unplug, do not just pull the power cord, you must hold the plug in your hand and pull it out.
  - ◆ There is dangerous high voltage in the control box, so to open the control box cover, you need to turn off the power supply and wait more than 5 minutes before opening the control box cover.

## ● Maintenance, inspection and repair

- Repair and maintenance operations should be carried out by trained technicians.
- Be sure to turn off the power when changing the needle and shuttle.
- Use factory parts.

## ● Other security countermeasures

- Please do not touch the rotating and moving parts (especially needles and belt accessories) while the sewing machine is running, and be careful not to approach them in order to avoid danger.
- The control device shall not fall to the ground, let alone plug other objects into the gap.
- Please do not operate under the condition of removing the covers.
- If the control device is damaged or unable to function properly, it is necessary to ask experienced technical personnel to adjust, or check and repair, please do not run it until the failure has been eliminated.
- Please do not modify or change this control device by yourself.

## ● Waste disposal

- Please treat it with general industrial waste.

## ● Warning signs and danger signs

- The wrong behavior may be dangerous, to the extent of the indication described below.

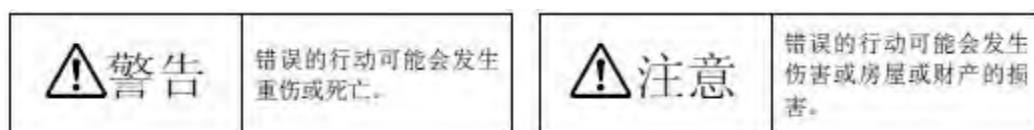

- The representation of the marking symbol is described below.





---

	请遵照指示内容作业。
	注意高温。
	绝对不要执行。

	注意高压电（电击）的危险。
	务必接上接地线。

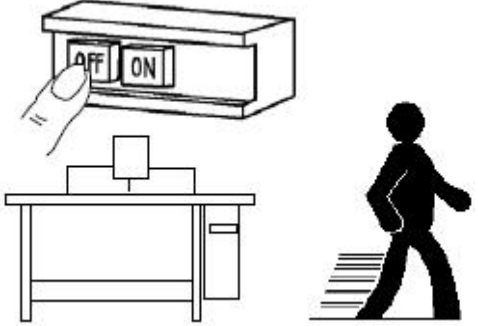
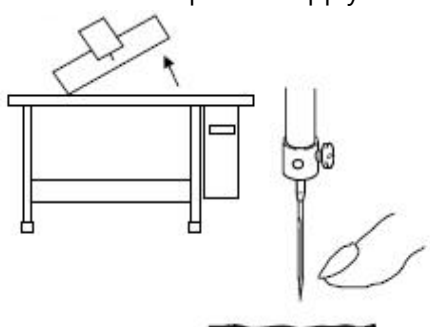
## 1.7 Precautions for use

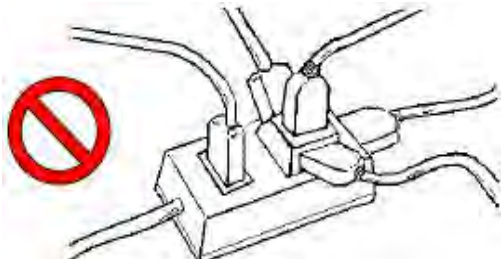

<p>1. When the hand presses the switch [ON], the foot must leave the pedal.</p> 	<p>2. Be sure to turn off the power when you want to leave your job.</p> 
<p>3. If you want to reverse machine head or change the needle or thread, be sure to turn off the power supply.</p> 	<p>4. Ground the ground wire.</p> 
<p>5. Do not use multi-jack extension cords for home use.</p> 	<p>6. There is dangerous high voltage in the control box, so wait 5 minutes before opening the control box cover.</p> 
<p>7. After replacing the motor, please refer to this information to set the installation angle of the spindle motor.</p>	
<p>8. Stay away from the machine that will cause high cycle noise interference.</p>	<p>9. If the external signal socket is used to connect the application accessory, the length of the cable should be as short as possible. The long cable ma</p>

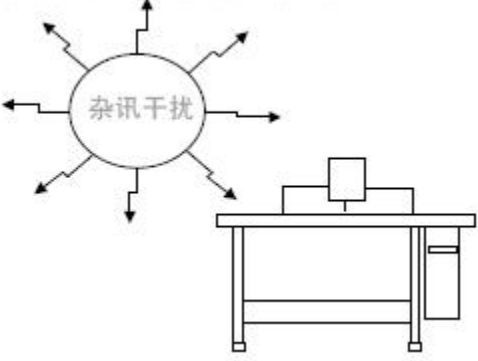
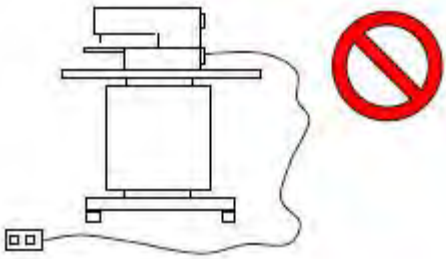
	<p>y cause malfunction. Use the isolation cable for the cable.</p> 
<p>10. If the fuse is blown, please remove the cause and then replace the fuse of the same capacity.</p>	

---

## 1.8 Standardization

The function buttons adopt the industry-recognized graphic logo, and the graphics are international languages that can be recognized by users all over the world.



## 1.9 Mode of operation

The touch panel operation panel of the system adopts the industry's advanced touch operation technology, and the friendly interface and convenient operation bring innovative changes to the daily use of the user. The user can tap the screen with a finger or other object to complete the corresponding operation. Users should take care to avoid touching the screen with sharp objects during use to avoid permanent damage to the touch screen.

The function keys include a preparation key, an information key, a mode key, and a communication key. Refer to the descriptions in the following sections for specific operation methods.

















**Users should take care to avoid touching the screen with sharp objects during use to avoid permanent damage to the touch screen.**

---

## 2 Instructions

### 2.1 Universal button

The buttons for general operation in all aspects of the system are as follows:

No.	Icon	Function
1		Confirmation key → Input interface enters the sewing interface / sewing interface to exit to the input interface
2		Information button → View version information and threading diagram
3		Communication key → U disk communicates with the panel to perform mutual copying of patterns or parameters
4		Set button → enter function interface
5		Pattern selection button → Open pattern file
6		Registration button → Register pattern file number
7		Name key → enter the name of the pattern
8		Electric presser foot height setting button → Set the electric presser foot height, the pneumatic presser foot is invalid
9		Medium presser foot height → Set the intermediate presser height
10		Adjustment button → Adjust the seam point
11		Threading key → Threading
12		Cancel button → Cancel current setting value / Exit current interface
13		Confirmation key → Save current setting value
14		Try sewing button → enter single step seam interface
15		Winding key → enter winding state

## 2.2 Basic operation

### ① Turn on the power switch

After the power is turned on, the data input interface is displayed.

### ② Select the pattern No. you want to sew.



The selected pattern No. will be displayed under the current interface. Press the pattern selection

button  and enter the sub menu to select the pattern No..

For details on the operation of pattern selection, see the section [2.8 Pattern Selection].



### ③ Set to a state that can be sewn

After pressing the ready button , the color of the button is darkened  to enter the pattern confirmation interface. In this case, the sewing can be performed.

### ④ Start sewing

Place the sewing product on the presser foot, step on the pedal to lower the presser foot, start the sewing machine, and start sewing.

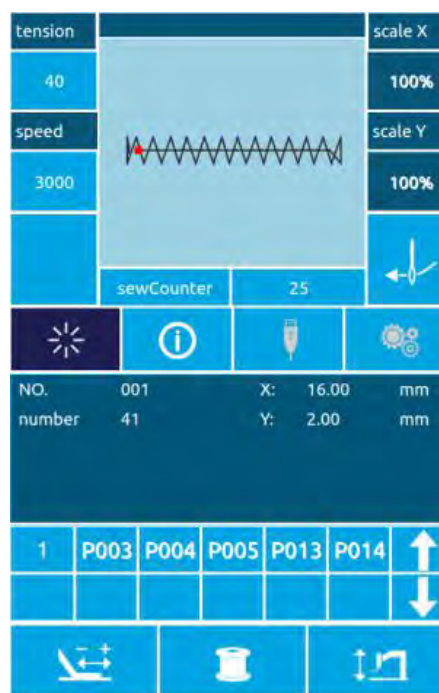

## 2.3 Ordinary pattern operation

### (1) Sewing data input interface

The data input interface is shown on the right. For detailed function description, please refer to the function key description table.

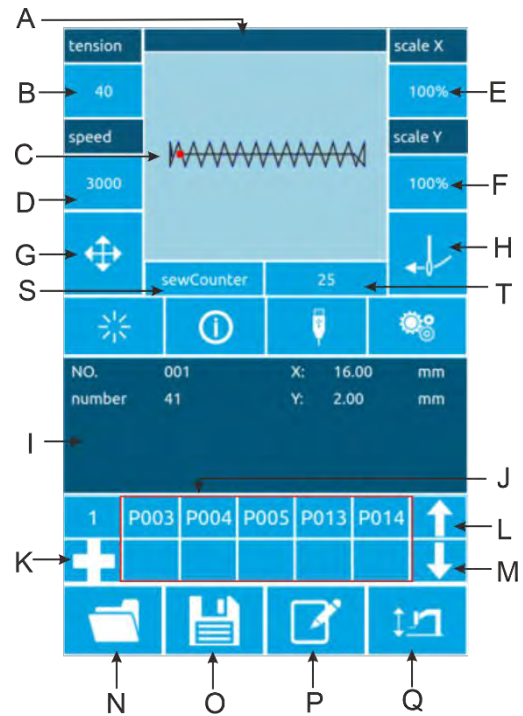

### Function Description:

No.	Function
A	Pattern name display area
B	Tension key
C	Pattern display area
D	Speed key
E	X zoom rate key
F	Y zoom rate key
G	Adjust the seam point key
H	Threading key
I	Pattern information display area
J	P pattern shortcut key area
K	P pattern registration key
L	P-page flip key
M	P pattern page down key
N	Pattern selection key
O	Pattern registration key
P	Pattern naming key
Q	Electric presser foot setting key
S	Counter mode key
T	Count value key

## (2) Sewing interface

Press to enter  the sewing interface as shown on the right. For detailed function descriptions, please refer to the function key description table.

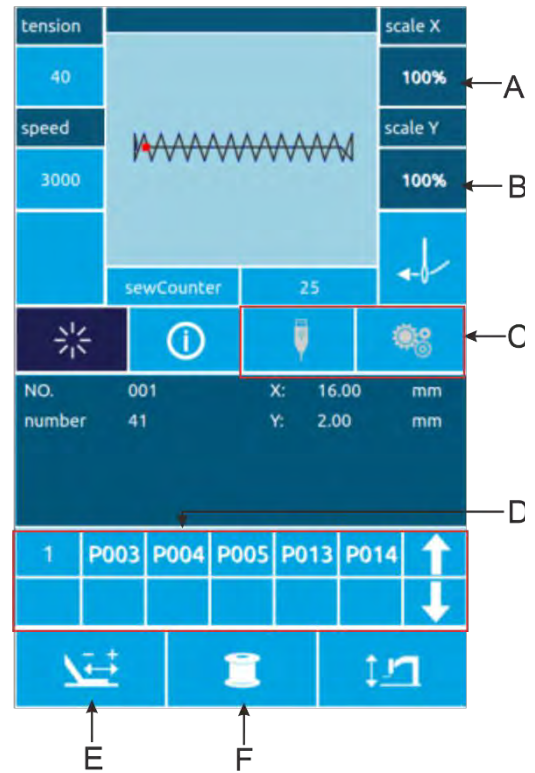

### Function Description:

No.	Function
A	X zoom rate display
B	Y zoom rate display
C	Inoperable key
D	P pattern area is not operational
E	Trial key
F	Winding key
---	Others keys with the same input interface function

---

## 2.4 Pattern registration

Up to 999 ordinary patterns can be registered. Press  to enter the pattern registration interface (as shown on the right):

### ① Enter the pattern number

The number of the pattern you want to enter can be selected by the number keys. The pattern number range must be 201~999. If you enter another number, the number range will be displayed.



### ② Register new tricks

After confirming the pattern number and pressing , the previously displayed pattern data will be copied to the new registration pattern, and after the operation is completed, return to the new registration pattern data input interface.

If the entered number is already registered, it will prompt whether to overwrite the saved pattern.

Press the key  to exit the registration interface.

## 2.5 Pattern naming

Press  to enter the pattern naming interface (as shown on the right).

A	delete	Delete input characters one by one
B	Right shift	Cursor right
C	Shift left	Cursor left
D	Empty	Clear all characters currently entered

Select the character you want to enter  and press the end pattern naming operation.

The position of the character can be determined by moving the cursor, and the delete key can eliminate the position character.

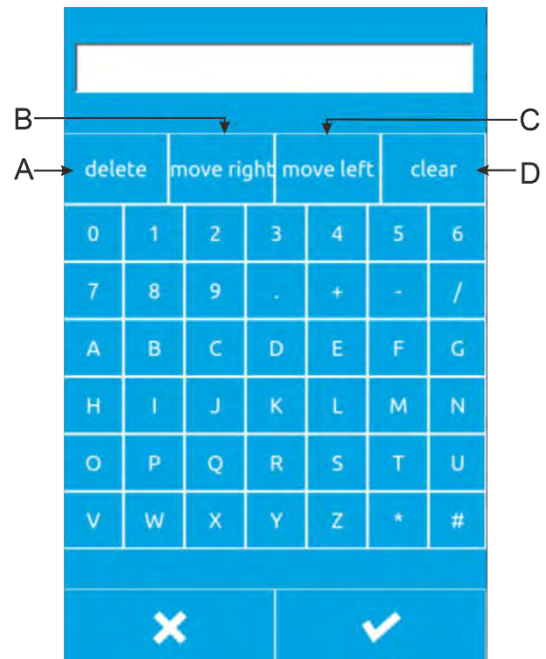

---

## 2.6 Winding

### ① Installation bobbin

Insert the bobbin into the bobbin. As shown on the right.

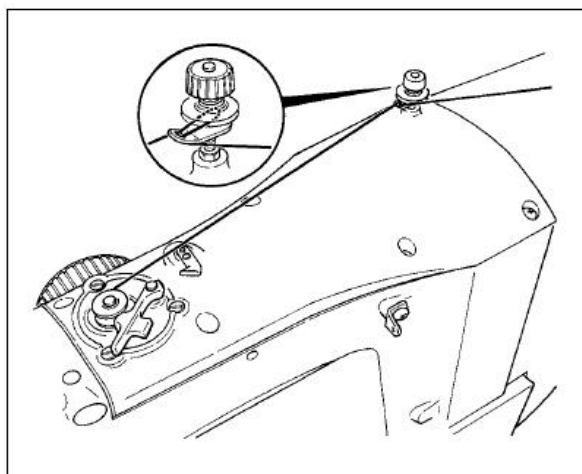

### ② Show bottom line winding interface

On the sewing interface, after the winding button  is pressed, the winding interface is displayed (as shown on the right).

### ③ Start winding

After stepping on the left pedal to press the foot, step on the start pedal to start winding.

### ④ Stop sewing machine

After the winding is started, when the starting pedal is stepped on again, the winding stops rotating. When the winding stops, the left pedal is pressed and the foot is raised to return to the sewing mode.

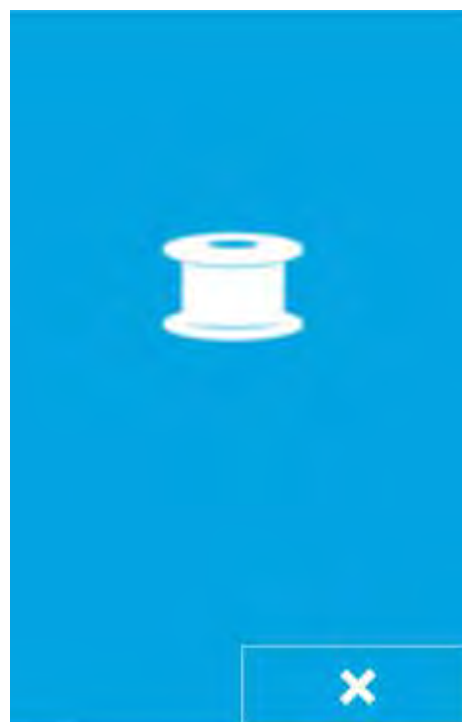

## 2.7 Threading

### ① Enter threading status

When the input interface or the sewing interface button  enters the threading state, the threading button turns

red , and the screen changes as shown in the figure. In this state, the machine cannot perform other operations.



### ② Exit threading mode

After threading is finished, press the key



 again to return to the input interface or sewing interface.

## 2.8 Pattern selection

### ① Enter the pattern selection interface

Data input interface (as shown in Figure 1 on the right), click on the selection button A to enter the pattern selection interface (Figure 2).

Figure 2 information is as follows:

A	Pattern name
B	Pattern size information
C	Pattern display
D	Registered pattern number
	Flipping on the pattern
	Flip page
	Pattern deletion

### ② Choose a pattern

The pattern number area D can display 25 pattern numbers per page; when a pattern number button is selected, the current pattern and information are displayed at the top. The pattern information includes a pattern number, a length in the X direction, a height in the Y direction, and a string named by the pattern (the unnamed pattern does not display a character string).

Press  to complete the pattern selection operation.

### ③ Pattern deletion

Select a pattern number button and press

 to delete the pattern.

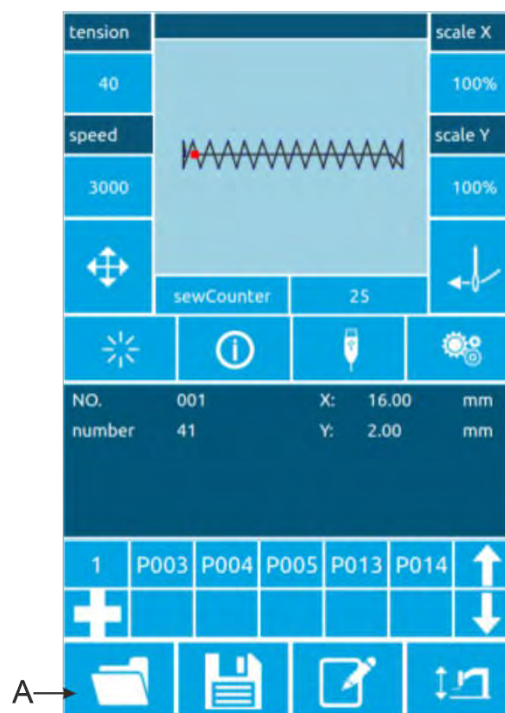

Figure 1

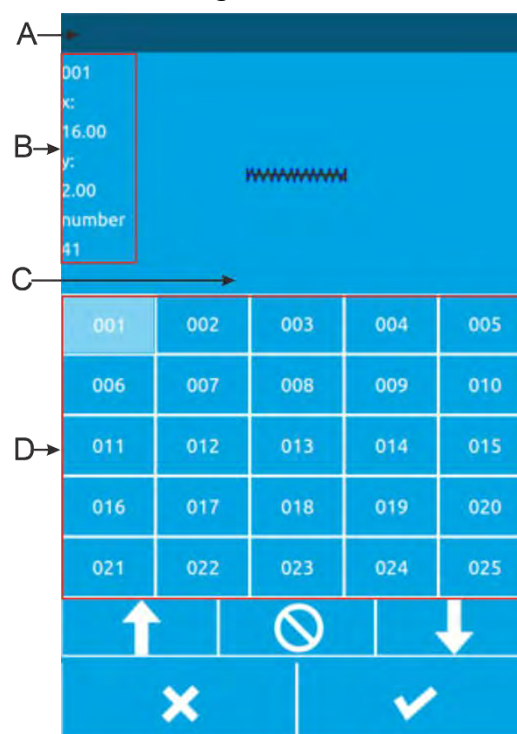

Figure 2

---

**Note: The pattern is divided into the basic pattern and the common pattern: the basic pattern is the factory pattern; the ordinary pattern is the pattern that the user can make, copy or import the U disk, the pattern can be deleted and modified, but the deleted pattern cannot**

## 2.9 Sewing data setting

### ① Enter the sewing data setting interface

Press A, B, and C respectively in the data input interface to enter the zoom rate setting and speed limit setting interface respectively.

	Item	Input range	Initial value
A	Tension value	0~120	40
B	Sewing speed	400~2800rpm (The upper limit is set in the super setting parameter)	2000rpm
C	X direction zoom ratio	1.0~200.0%	100.0%
D	Y direction zoom ratio	1.0~200.0%	100.0%
E	Presser foot height	430Q:10~17mm	14mm
		438Q:6~13mm	10mm
		630Q: 10~17mm	14mm

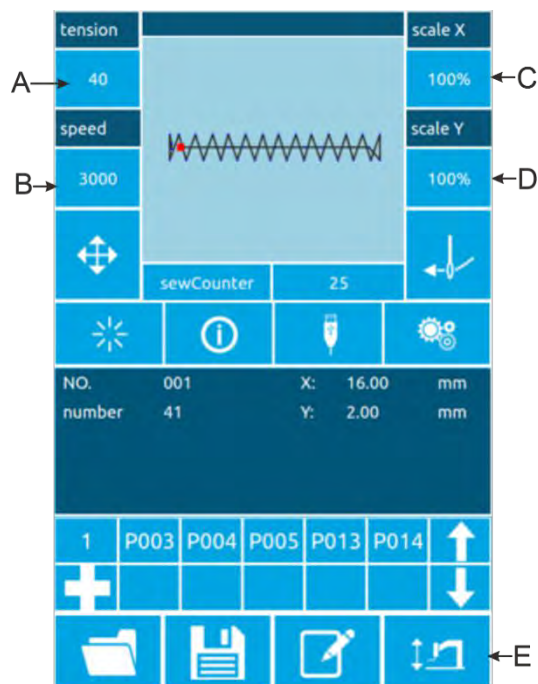

Note: The maximum speed limit is limited in "Super Settings → Parameter Settings → 3: Maximum Sewing

Speed”.

## ② Zoom rate setting

The picture on the right is the enlargement /reduction ratio setting interface. The upper part of the interface is set in the X direction, and the lower side is set in the Y direction.

A	X direction zoom rate display
B	Actual length value display in the X direction
C	Y direction zoom rate display
D	Actual length value display in the Y direction

Enter the desired value through the numeric keypad or the +, - keys. The entered number is inserted into the first digit of the displayed value. The previously entered digit is progressively one bit at a time. Press the OK

button  to complete the operation and return to the data input interface.

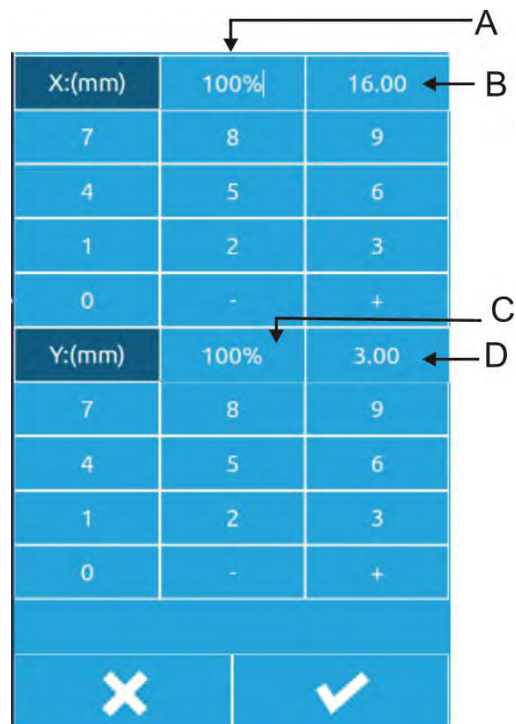

### ③ Speed value setting

Operation as above

### ④ Medium presser height setting

Operation as above

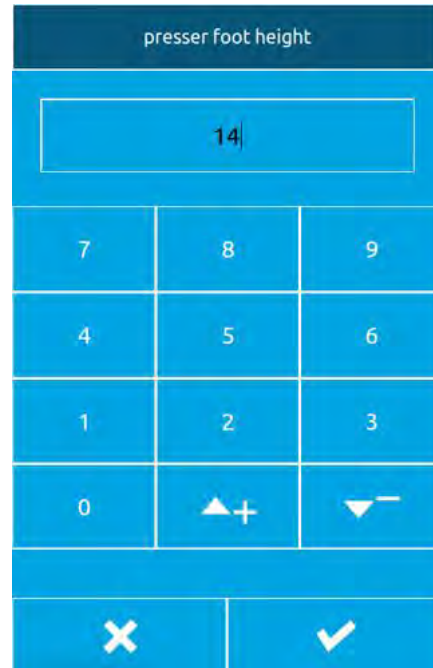





## 2.10 P pattern registration

### ① Enter the P pattern registration interface

When the normal pattern is displayed under the data input interface, press  to enter the P pattern registration interface, as shown in the right figure.

### ② Enter the P pattern number

Enter the number you want to register by using the  ~  ten-digit keyboard or ,  key. If you have entered the registered pattern number, you will be prompted that the number is already occupied. In this case, the user needs to re-enter the number you want to register.

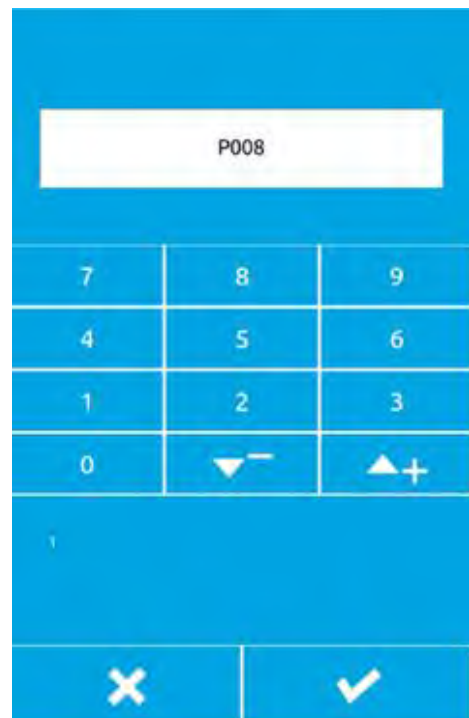

### ③ Select folder number

The P pattern number can be registered in 26 folders, and each folder can hold up to 10 P patterns. A is the current folder, press

the  and  keys to switch folders.

③ **Determine the pattern number**

Press the  to complete the P pattern registration operation and return to the P pattern data data input interface as shown.

④ **Delete P pattern**

Select the P pattern number and press the  to delete the current P pattern number.

⑥ **View registered P pattern**

Press the following two buttons to see how many P patterns have been registered.

Users can register up to 255 P patterns.

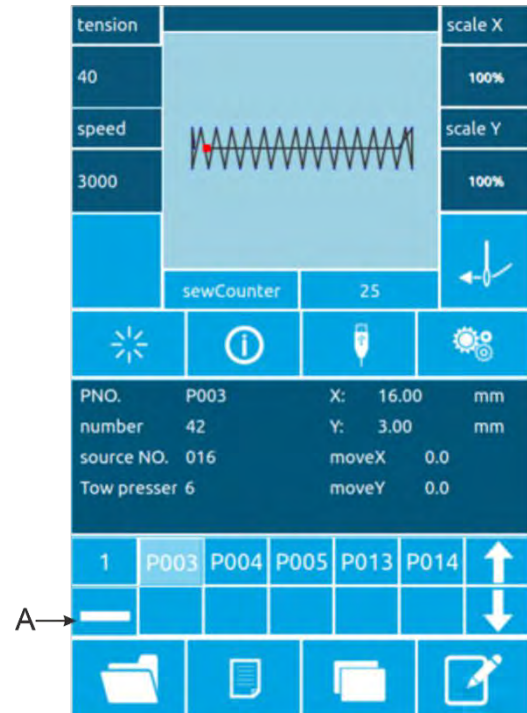

:P pattern flipping

:P pattern page down



## 2.11 Trial operation







### ① Display sewing interface

On the data input interface, after pressing the ready button , the ready button changes to the status , indicating that the sewing interface has been entered.

### ② Display trial seam interface



Under the sewing interface, press the

key  to enter the trial seam interface (as shown on the right):

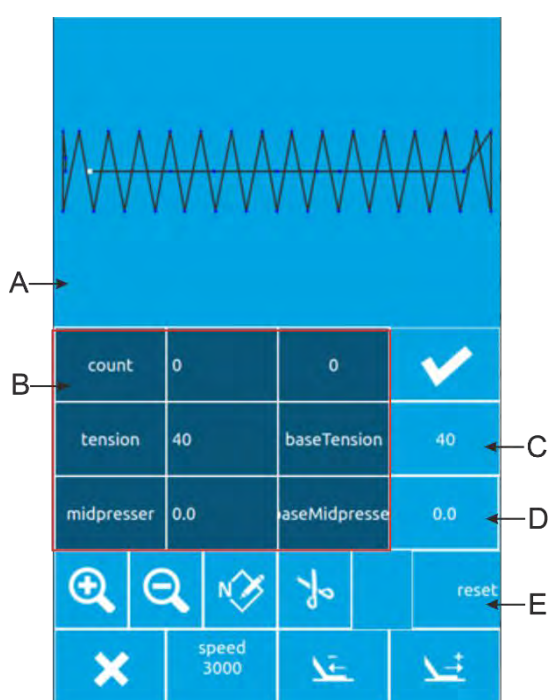
A	Pattern display area
B	Pattern info display area
C	Tension reference setting button
D	Middle-presser foot refer setting button
E	Home position reset button
	Single needle back button
	Single needle advance button
	N needle moving button
	Trimming button
	Graphic display zoom button
	Graphic display zoom button



### ③ Start trial stitching

After entering the trial seam interface, the presser foot is lowered, and the presser foot back button  and the presser foot forward button  are used to determine the shape.

Or use the N pin forward button  to move directly to the Nth pin.

### ④ Trial seam interface start sewing

At the trial seam interface, the start pedal can be stepped directly at any position, and the machine will start sewing from the current position and return to the sewing interface.

⑤ **End trial seam**

After pressing the Cancel button  to exit the trial seam interface, return to the sewing interface and return to the starting position of the pattern.

## 2.12 Counter operation

① **Display counter interface**

In the input interface or sewing interface, the position of the counter is displayed as shown in Figure A and B.

A	Counter mode key	1:sewing counter 2:Needle counter
B	Count value display key	1:Number of sewing parts 2:Number of stitches

The user can directly click the A counter mode button to quickly switch the "counting counter/counter counter" and display the corresponding "number of pieces/number of stitches" at the position of the B button.

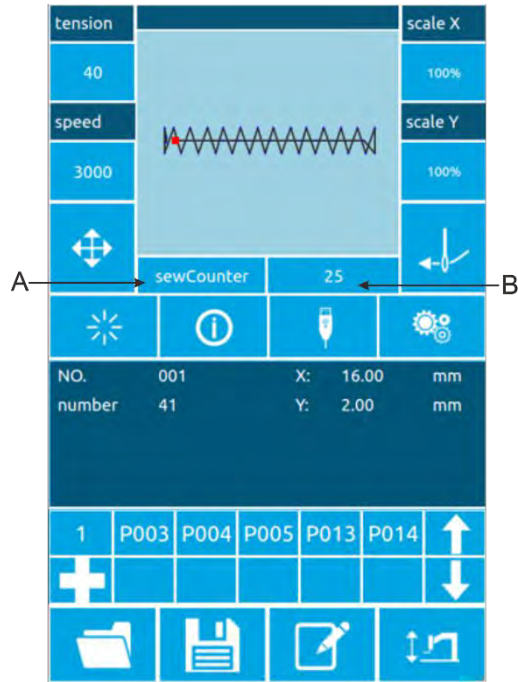

② **Counter clear operation**

Click button B to pop up the recounting interface. As shown in the figure, click the C button, the counter is cleared, and return to the previous interface input interface/sewing interface.



③ **Set counter operation**

Click the D button in the setting interface to enter the counter setting interface.

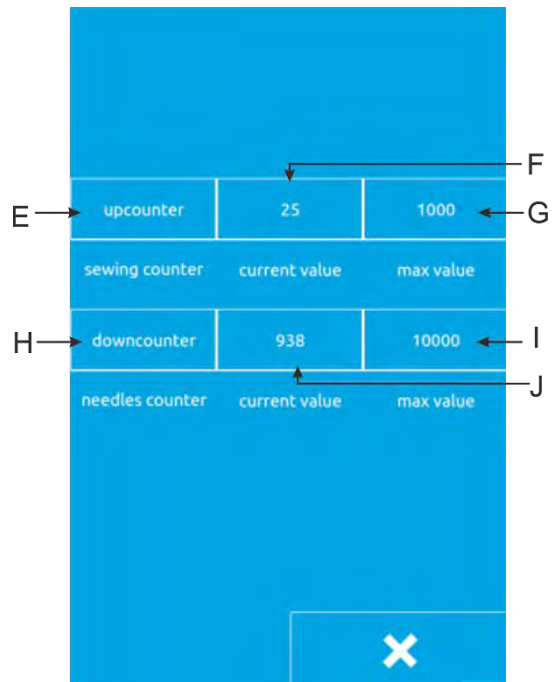
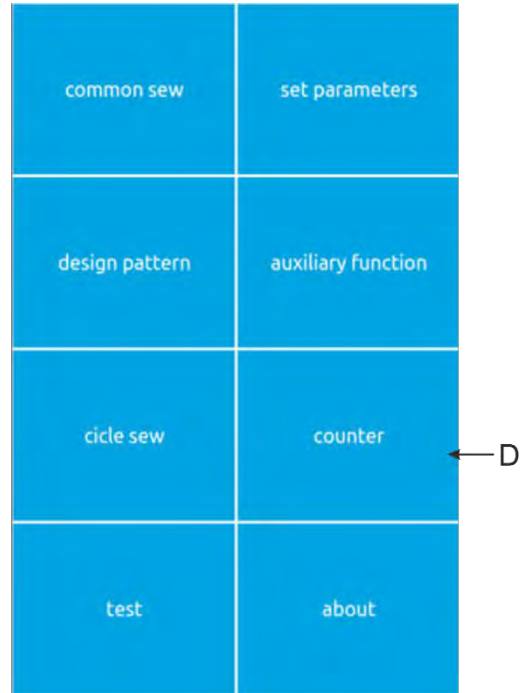

E	Sewing counter mode
F	Piece current count value
G	Sewing counter maximum
H	Needle counter mode
I	Needle count current value
J	Needle counter maximum





## 1.Set the counter type

Click the E or H button to enter the counter mode setting interface.

The mode can be set to "up counter / down counter / no counter", after the mode setting is completed, press the button , Go back to the previous screen.



## 2.Set count value

Click F/J or G/I to set the current count value and the maximum count value respectively. Through  ~  + number key or ,  key to put number.

**Note: The maximum value of the sewing counter is 9999 pieces, and the maximum value of the needle counter is 65000 pieces.**

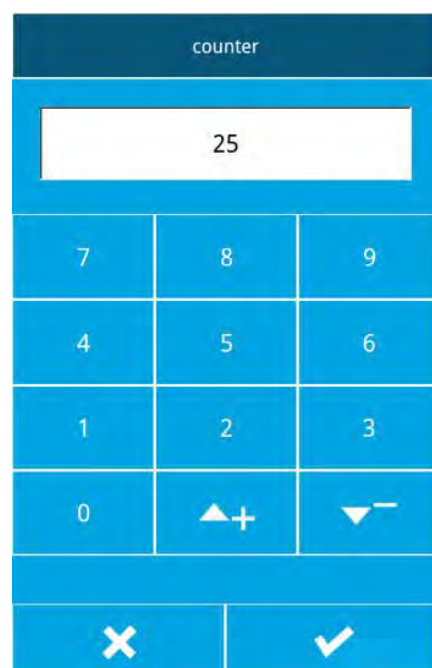

## 2.13 Adjust the stitching point operation

### ① Enter the adjustment sewing point interface

In the data input interface, after pressing the adjust sewing point button , Enter the adjustment sewing point interface. As shown on the right.

A	Simulated stitch back button
B	Simulated sewing advance button
C	Current number of stitches
D	Move the needle number selection button once
E	Adjustment data display
F	Display graphics area
G	Adjust the stitching point to move the keyboard
H	Lift the middle presser foot button

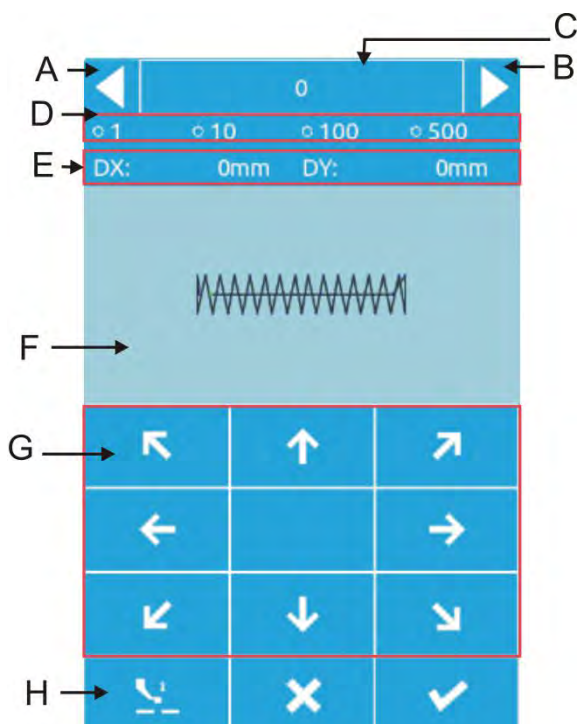

### ② Start adjusting the stitching point

Press the moving keyboard of the G area to move the seaming point to make the machine aim at the seaming point of the template. After finishing the seaming point, you can press the A and B buttons to “simulate the button” to check if it is aligned.

The simulation walks by default by one stitch at a time. You can select to move 10 stitches, 100 stitches or 500 stitches at a time by clicking the D area radio button.

**Note: The standard for the seaming point has been aligned: there is no deviation between the needle and the sewing path of the pattern. If there is a deviation, the adjustment still needs to be continued. After confirming**

**the adjustment, press the button  to confirm the offset.**

### ③ End trial sewing

After pressing the Cancel button  to exit the adjustment interface, return to the input interface.

---

## **2.14 Emergency stop**

After the emergency stop switch is pressed, press the enter key to enter the sewing interface. You can use the trial sewing interface to advance the needle number, rewind or trim the thread. For the operation steps, refer to [2.11 Trial Sewing Operation].

### 3 Fast (P) pattern operation

#### 3.1 P pattern data input

The quick pattern is abbreviated as P pattern, which consists of a common pattern and related pattern sewing parameters (X zoom rate, Y zoom rate, speed limit, etc.). P-patterns do not need to be set each time.

The P pattern data input interface is as shown on the right.

Up to 255 P patterns can be registered.

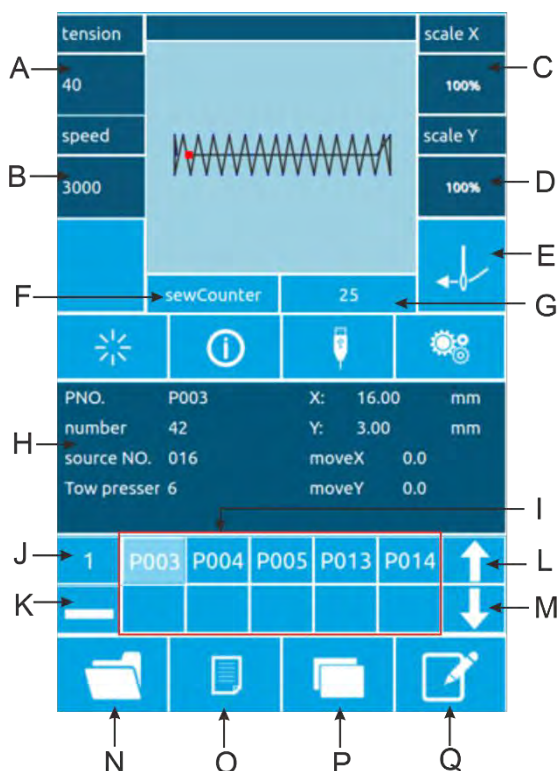

#### Function Description:

Serial number	Function	Content
A	Tension value	Display current pattern tension
B	Speed value	Display current pattern speed value
C	X zoom rate	You can enter up to 14 characters
D	Y zoom rate	After pressing, the outer presser foot is lowered
E	Threading	When pressed, the red  is threaded and no other operations can be performed.
F	Counter mode	It is divided into sewing counter and needle counter. Click button to quickly switch counter mode and count display.
G	Counter value	Display the corresponding current count value according to the counter mode
H	P pattern information display	Displayed as the current P pattern sewing information.

---

I	Registered P pattern	The button can quickly switch the P pattern.
J	P pattern number of pages	The number of pages of the current P pattern is displayed, and the button can sequentially switch the P pattern page number.
K	P pattern delete button	Click this button to delete the selected P pattern.
L	P pattern on page	Click the button P to turn the page
M	P pattern under the page	Click the button P to turn the page
N	Ordinary pattern selection button	Click the button to select the registered common pattern
O	Ordinary pattern registration button	Register a new general pattern
P	P pattern copy button	Can copy the current P pattern content to an empty pattern number
Q	Pattern naming key	Can name the current pattern

## 3.2 P Pattern Editing

### ① Enter the P pattern editing interface

Press this button  to enter P pattern editing interface (as shown on the right)





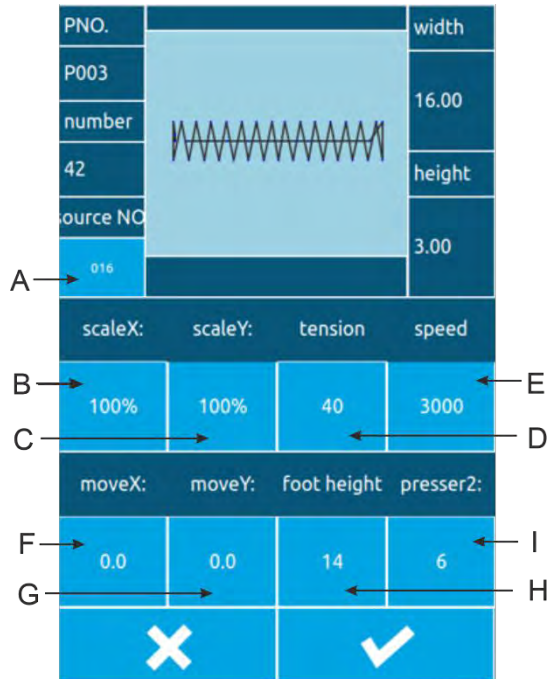

### ② Edit project data changes

Select the item you want to change and set the value

	Item	Input range	Initial value
A	Original number	---	---
B	X direction zoom	1%~400%	100.0%
C	Y direction zoom	1%~400%	100.0%
D	Sewing tension	0~120	40
E	Sewing speed	400~2800rpm	2000rpm
F	X offset	-99.9~99.9	0.0mm
G	Y offset	-99.9~99.9	0.0mm
H	Middle presser foot height	0.0~7.0mm	2.0mm
I	Secondary presser foot	0~10	6mm



### ③ Identify data changes

Take the X direction offset as an example, through  ~  number keyboard or ,  key to input number, press the confirm key  to finish. : Represents positive and  negative values;

### ④ Exit editing

Press the Exit key  to close the P pattern editing interface and return to the data input interface.







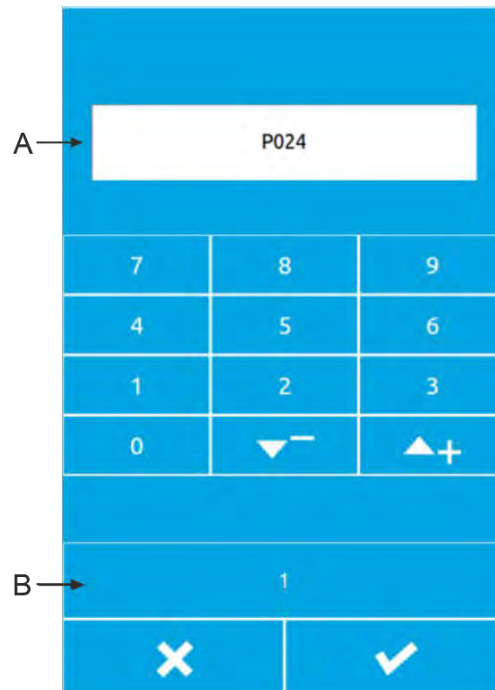

### 3.3 P Pattern paste

#### ① Select the copied pattern

Press  to enter the P pattern copy interface (as shown on the right).



#### ② Enter the newly registered pattern number

A is the empty number automatically selected by the system, and B is the number of pages. The user can directly copy the current P pattern to the number; , or can through  ~  + number keyboard or ,  key to put the destination number you want to copy. The registered pattern number cannot be registered repeatedly, and the system will prompt an error. B button can change the number of pages, Press the button  to confirm the copy and return to the P pattern input interface.

### 3.4 P Pattern sewing

In the P pattern data input interface, press  to enter the sewing interface.

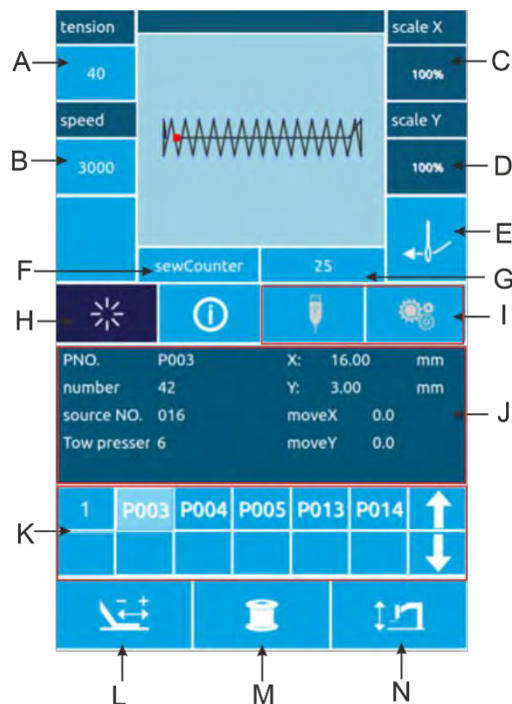

#### Function Description:

Item	Function	Content
A	Tension button	Press the button to enter the tension setting interface to set the sewing tension value.
B	Speed button	Set the current sewing speed.
C	X direction zoom display	Displays the X zoom ratio of the current pattern.
D	Y direction zoom display	Displays the Y scaling rate of the current pattern.
E	Threading button	When pressed  , the button turns red and enters the threading state. No other operations can be performed at this time.
F	Counter mode button	Press the button to quickly switch the “Sewing Counter/Needle Counter” .
G	Count display button	According to the mode of the F button, the corresponding count is displayed. After pressing, the clear interface can be entered, and the current count can be cleared.
H	Pattern confirmation button	Switch "pattern input status/sewing status".
I	Inoperable button	The current state is not operational.

---

<b>Item</b>	<b>Function</b>	<b>Content</b>
J	Pattern information display	Displays the parameter values of the current pattern.

---

K	Inoperable button	The current state is not operational.
L	Trial sewing button	Press the button to enter the trial sewing interface and confirm the pattern stitch.
M	Winding button	Press to enter the winding interface.
N	Medium presser foot height button	Press the button to enter the intermediate presser height setting interface to set the height of the intermediate presser.

---

## 4 Combination (C) pattern operation

### 4.1 C Pattern data input

The combination pattern is abbreviated as C pattern, which is composed of a set of P patterns, and each group of C patterns can include up to 6 sub-patterns. A total of up to 50 sets of C patterns can be registered.

As shown on the right.

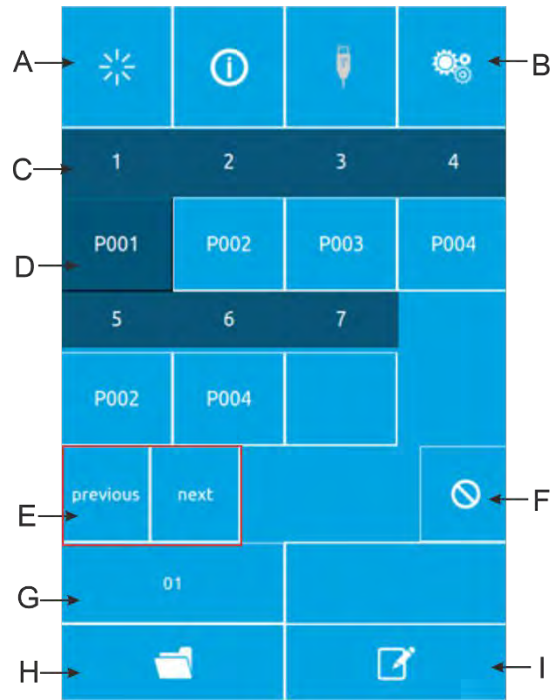

---

## Function Description:

No.	Function	Content
A	Enter	Entering the sewing state
B	C pattern copy	You can copy the current C pattern content to an empty pattern number.
C	Sewing order display	The sewing order of the currently selected pattern is displayed, and the blue color is displayed as the starting sewing pattern.
D	C pattern selection	Press to enter the C pattern editing interface, you can choose to enter a P pattern.
E	Page key	Up to 30 C pattern can be registered, and up to 6 patterns can be displayed per page.
F	Delete key	Delete C pattern sequence
G	C pattern number selection	The currently selected pattern number is displayed on the button, and the C pattern selection interface is entered after pressing.
H	C pattern registration	Register a new combination pattern.
I	Pattern naming	Enter the string you want to name
J	C pattern name	The C pattern name is displayed.

## 4.2 C pattern editing

### ① Enter the C pattern editing interface

In the C pattern data input interface, press A to enter the C pattern editing interface.

In the initial state, the P pattern is not registered as the sewing pattern, so the first pattern is displayed in a blank state.

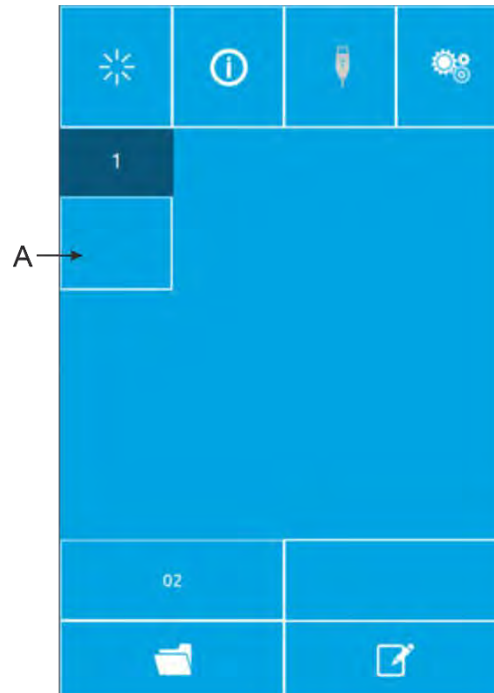

### ② Selection pattern

The picture on the right is the C pattern editing interface. Select the P pattern of the B area you want to register, and press the OK button  to end the selection.

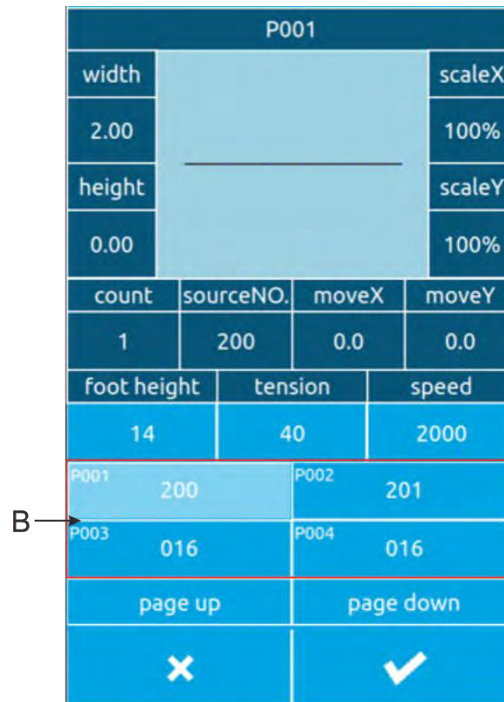

---

③ **Repeatedly registering the remaining patterns**

After a pattern registration is determined, the next pattern selection key C is displayed as shown above, and the operation is the same as above, and other remaining patterns can be repeatedly registered.

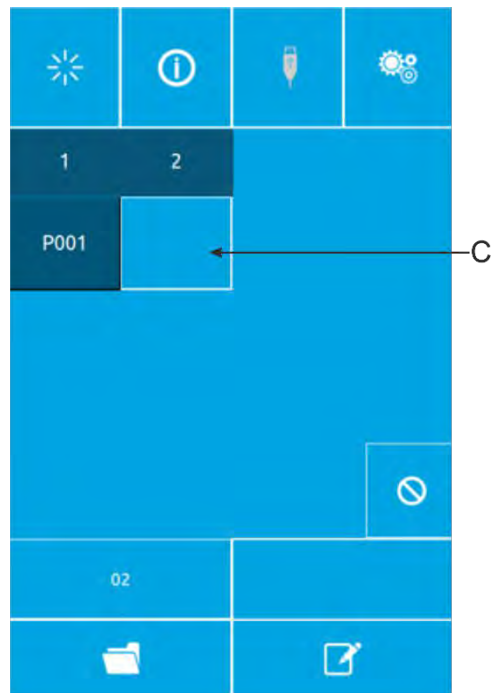

### 4.3 C pattern selection

① **Enter the C pattern selection interface**

As shown on the right, press icon A to enter the C pattern selection interface.

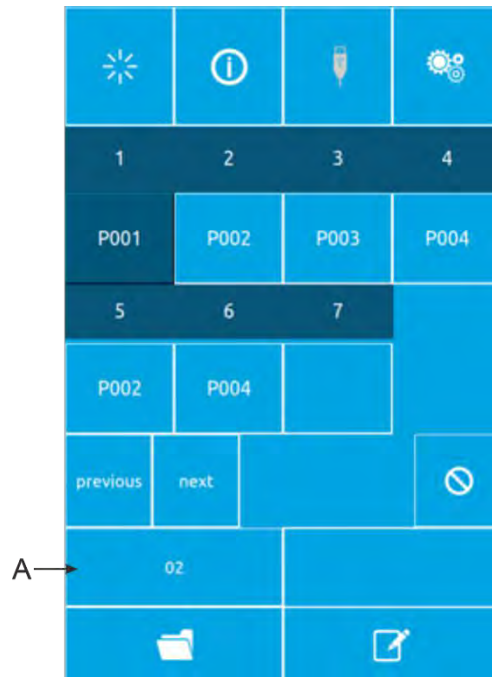

② **Select C pattern number**

The picture on the right is the C pattern selection interface. After pressing the B button, the P sub-pattern data input under the current C pattern can be sequentially changed.

Determine the C pattern number key C you want to select, and press the OK

button  to end the selection.

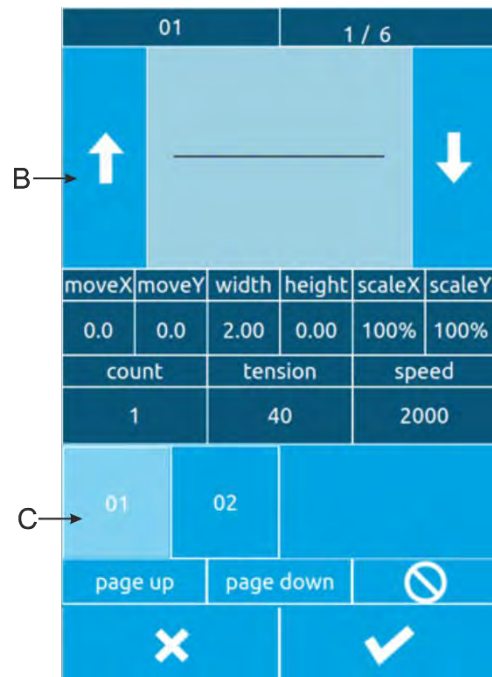

## 4.4 C pattern sewing

In the C pattern data input interface, press  to enter the sewing interface (as shown on the right).

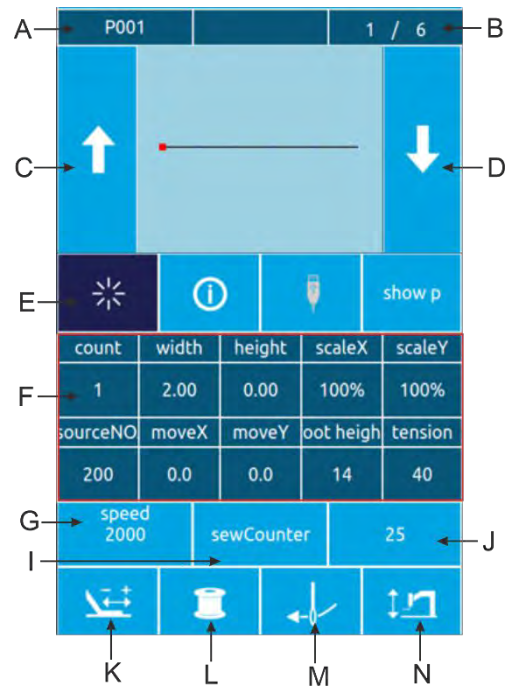

### Function Description:

No.	Function	Content
A	Sewing shape number display	Displays the sub-pattern number registered under the current C pattern.
B	Sewing order display	Display the sewing sequence number in the current sewing pattern
C	Sewing pattern switching button	Press the back sewing pattern to switch to the previous pattern of the current sequence.
D	Sewing pattern switching button	Press the back sewing pattern to switch to the next pattern in the current sequence.
E	Pattern confirmation button	Switch the C pattern input interface status and sewing interface status.
F	Pattern information display	Displays parameter information of the current sub-pattern in the current sewing sequence.
G	Sewing speed key	Sets the sewing speed of the current sub pattern in the current sewing sequence.
H	Medium presser foot height button	Sets the intermediate presser height of the current sub-pattern in the current sewing sequence.
I	Counter mode button	Set the current count mode, "Sewing count/number of stitches" .
J	Pattern count display	According to the setting of I, the corresponding count "number of pieces / number of stitches" is

<b>No.</b>	<b>Function</b>	<b>Content</b>
		displayed.
K	Trial sewing button	Press to enter the trial sewing interface, confirm the stitching trend of the current sub-pattern in the current sewing sequence.
L	Winding button	Press to enter the winding interface.
M	Threading button	When pressed, the button turns red  and enters the threading state. No other operations can be performed at this time.
N	Medium pressure foot lift button	It can control the lifting of the intermediate presser foot.

## 5 Pattern editing

### 5.1 Enter the pattern editing mode

Press the normal sewing to switch the data input interface and mode selection interface (as shown on the right), in which you can perform some detailed settings and editing operations.





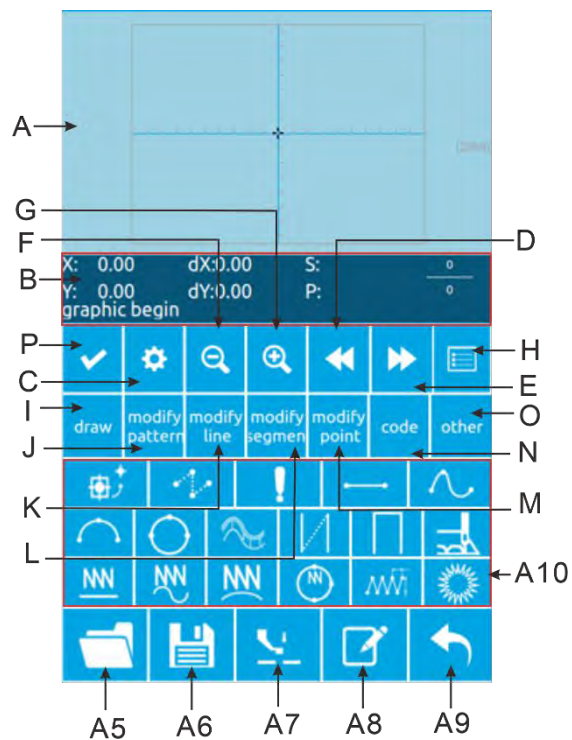











common sew	set parameters
design pattern	auxiliary function
cicle sew	counter
test	about

Press the pattern play button to enter the pattern editing interface.



## Function Description:

No.	Function	Content
A	Pattern display area	Display pattern
B	Current needle position status information display area	Display the current needle position information
C	Property settings	Can set attributes such as back stitch
D	Back feed	Move the current needle position backward
E	Forward feed	Move the current needle position forward
F	Zoom out	Zoom out the pattern
G	Zoom in	Enlarge the pattern
H	function list	Display the functions in the play version in the form of a list
I	Drawing	A10 area shows the drawing related button
J	Whole picture modification	A10 area shows the whole map modification related button
K	Complete line modification	A10 area shows the entire line modification related button
L	Segment modification	A10 area shows the segment modification related button
M	Point modification	A10 area shows point modification related button
N	function code	A10 area displays function code related buttons
O	other	A10 area shows other related buttons
A5	turn on	Open the pattern file
A6	save	Save the current display pattern as a pattern file
A7	Intermediate presser lift	Lifting or lowering the intermediate presser foot
A8	name	Name the pattern
A9	drop out	Exit the pattern

No.	Function	Content
A10	Dynamic button display area	According to different choices of buttons (I, G, K, L, M, N, O), the corresponding related buttons are displayed.
	Empty delivery	Draw empty
	Point stitch	Draw a point seam
	Straight seam	Draw a straight line
	Curved seam	Draw a curve
	Circular seam	Draw an arc
	Round seam	Draw a circle
	Multiple seam	Draw multiple seams
	Co-directional double seam	Drawing the same direction double seam
	Reverse double seam	Draw reverse double seam
	Straight zigzag	Draw a straight zigzag
	Curved zigzag	Draw a curve zigzag
	Circular zigzag	Draw a circular zigzag
	Round zigzag	Draw a circular zigzag
	Straight zigzag 2	Draw a straight zigzag 2 (multiple points can be set for each segment)
	Jump seam	Draw a jump seam
	template	Drawing template
	Second origin	Add a second origin

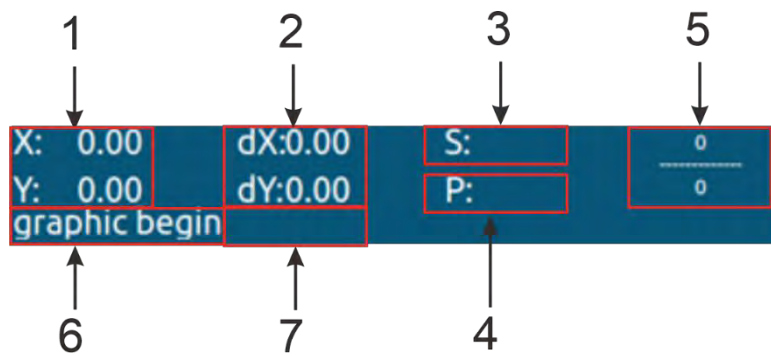

No.	Item	Content
1	Absolute coordinates	Indicates the absolute coordinates of the origin from the current needle position.
2	Relative coordinates	Indicates the relative coordinates of the current needle position.
3	speed	Indicates the sewing speed or the idle speed of the current point.
4	interval	Indicates the current factor sewing stitch length.
5	Contacts	The numerator indicates the current number of stitches, and the denominator indicates the total number of stitches.
6	Needle type	Indicates the type of needle drop position.
		The beginning of the pattern indicates the starting position of the pattern.
		The middle point of the line segment indicates the midway point of a line (that is, it is not a vertex or a line segment terminal).
		The vertex is the vertex of the polyline.
		The line segment terminal indicates the end position of a line.
		The pattern terminal indicates the final position of the pattern.
7	Line or function code type	When sewing data, the type of the line (empty feed, broken seam, curved seam, etc.) is displayed. When the function code is displayed, the type of the function code (tangent line, etc.) is displayed.

## 5.2 Pattern Edition

Using the pattern editing function, enter the following pattern.

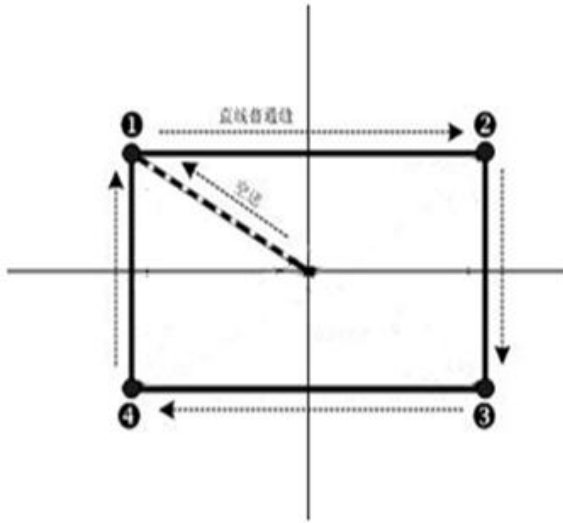

Input point:

	X (mm)	Y (mm)
1	-10.00	8.00
2	10.00	8.00
3	10.00	-8.00
4	-10.00	-8.00

Input order: as indicated by the dashed arrow in the left figure.

### ① Input for jumping

In the pattern editing standard interface, press

jump button , it shows jump setting interface (As shown on the right).

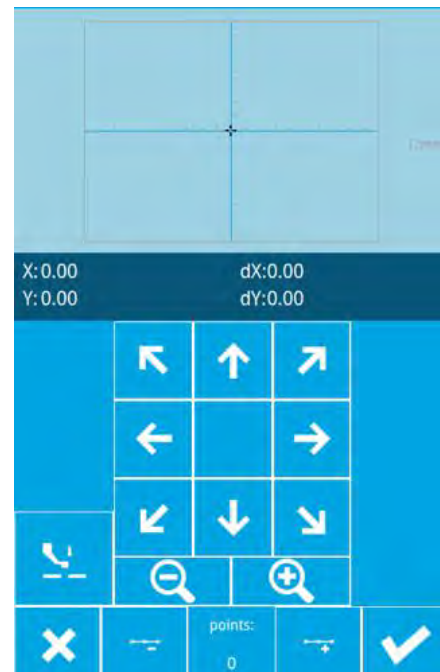

In the empty position designation interface, use the move button to move the cursor (needle position) to (-10, 8), press the 1 button  to confirm, return to the pattern editing standard interface and display the empty feed stitch (as shown on the right).



## ② straight ordinary sewing input

After Pressing the seam key in the pattern editing standard interface , Enter the straight line normal stitch setting interface, as shown on the right. Press the 2, 0 number keys in sequence to change the stitch length to "2.0", press the enter key to confirm and return. Straight line normal seam setting interface.



After confirming the needle distance shows “2.0mm”, press confirm

button , enter the straight line normal seam position setting interface.

In this interface, press the move button to move the cursor (needle position) from 1 to 2, then press the insertion point button.

 Repeat the above movement operation to move the cursor in the order of 1→2→3→4, as shown in the right figure.



After confirming the pattern, press this

button  to make the pattern data and return to the pattern editing standard interface, it shows the pattern.

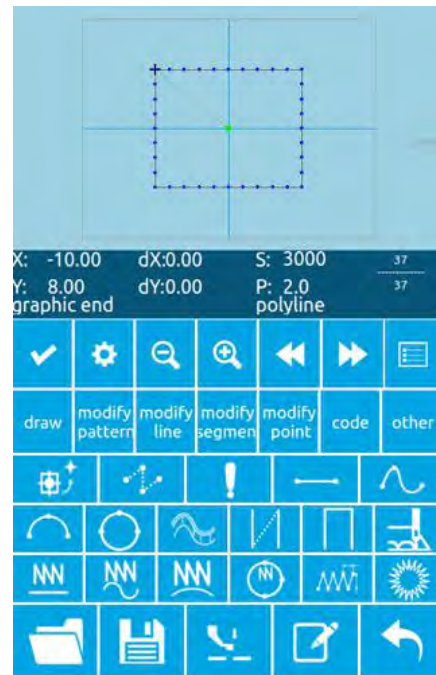

---

③ **Save pattern**

Press this button , enter the pattern design save interface and save the edited pattern, as shown on the right.

The system automatically sets the sample number, and the user can also enter the desired value through the numeric keypad. Press this

button  to save the pattern.



## 5.3 Pattern modification

### 1: Draw pattern

- (A): Draw a short delivery
- (B): Draw a point seam
- (C): Draw a straight line
- (D): Draw a curve
- (E): Draw an arc
- (F): Draw a circle
- (G): Draw multiple seams
- (H): Draw double seams in the same direction
- (I): Draw the second origin
- (J): Draw reverse double seams
- (K): Draw curved zigzag seams
- (L): Draw arc zigzag seams
- (M): Draw a round zigzag seam
- (N): Draw straight zigzag seam 2 (each segment can set multiple points)
- (O): Draw jump seams
- (P): Draw straight zigzag seams 1
- (Q): Drawing template

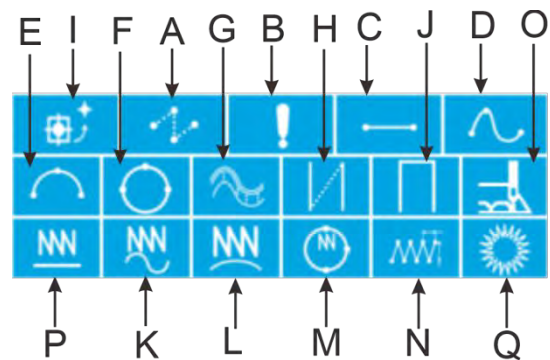

### 2: The whole picture is modified: according to the whole picture modification button, the dynamic button display area displays the following function buttons:

- (A): Move the sewing start point button
- (B): Modify the stitch length of the entire graph
- (C): delete
- (D): Copy
- (E): Origin mirror
- (F): X mirror
- (G): Y mirror
- (H): Rotate copy
- (I): Rotate
- (J): Clean up and empty delivery (retain the secondary origin)
- (K): Clean up air delivery and secondary origin

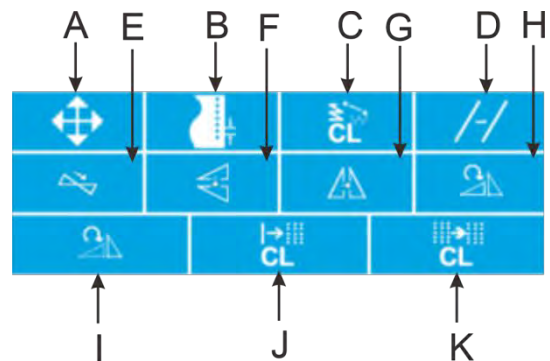

### 3: Complete line modification button: Press the entire line to modify the button. The dynamic button display area displays the following function buttons:

(A): Modify the stitch length of the current thread

(B): Move the current line

(C): Move multiple lines

(D): Copy the current line

(E): Delete the current line

(F): Move the current line and all following lines

(H): X mirror

(I): Y mirror

(J): Origin mirror

(K): Rotate

(L): Rotate copy

(M): flip

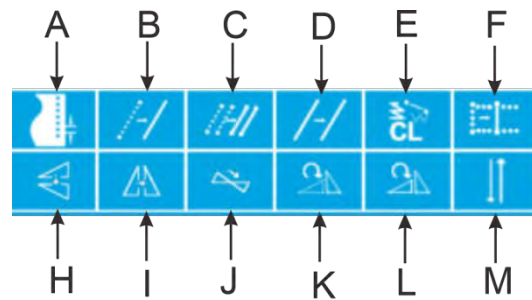

**4: Segment modification button: Modify button by segment The dynamic button display area displays the following function buttons:**

(A): Section movement

(B): Section modification

(C): Section deletion

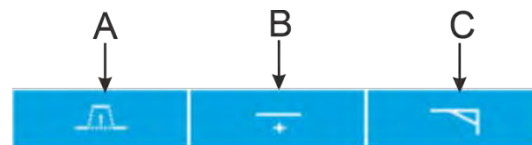

**5: Click the Modify button: Press the Point Modify button. The Dynamic Button display area displays the following function buttons:**

(A): Moving point

(B): Add point

(C): Delete point

(D): Add empty delivery point

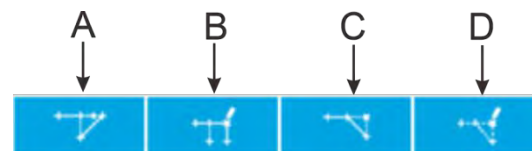

**6: Function code button: Press the function code button. The dynamic button display area displays the following function buttons:**

(A): Trim the thread

(B): Stop midway

(C): Thread tension reference value

(D): Reference value of middle presser foot height

(E): Thread tension

(F): Middle presser foot height

(G): Delete function code

(H): Change the sewing speed

(I): Change the air feed speed

(J): External input

(K): External output

(L): Edit function code

(M): Sliding, flipping and other special

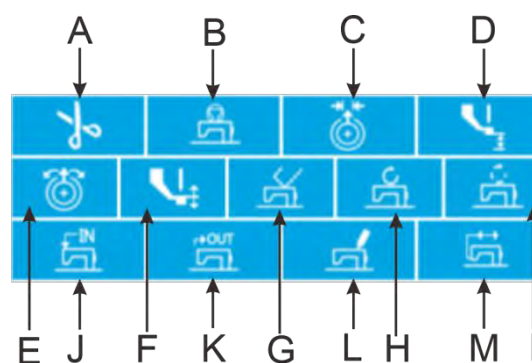

---

expansion equipment.

**7: Other: Press other buttons. The dynamic button display area displays the following function buttons:**

- (A): Move to the specified needle
- (B): Replace template function
- (C): Move the jump
- (D): Press frame

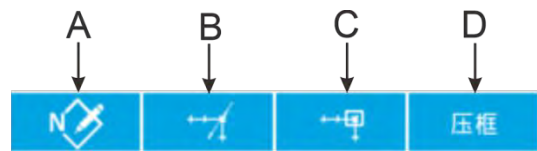

---

## 5.4 Exit pattern editing mode

Under the standard editing standard interface, press this button  to enter the mode choosing interface, as shown on the right.

common sew	set parameters
design pattern	auxiliary function
cicle sew	counter
test	about

---

## 6 Information function

### 6.1 View version information

#### 1 Display information interface

In the data input interface, after pressing the information button (A) as shown on the right, the information interface is displayed.

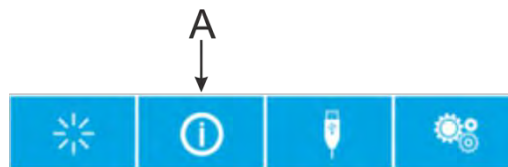

#### 2 Display the version interface.

Please press the version button of the information interface, and the version interface will be displayed. On the version interface, you can view the version information.

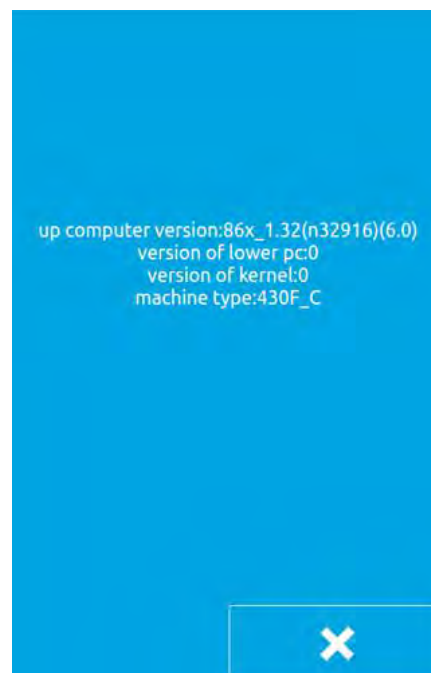
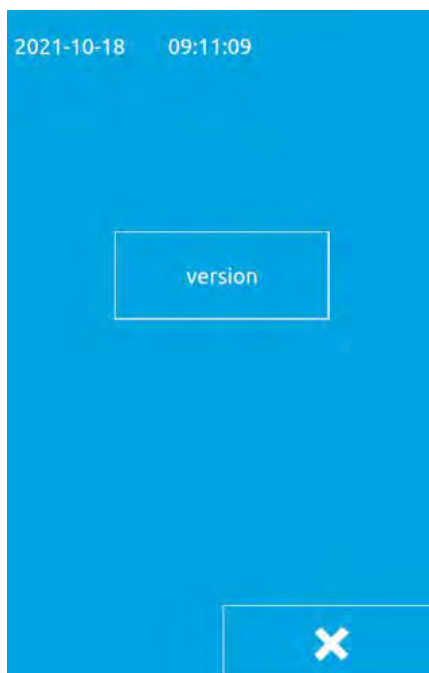

---

## 7 Communication function

The communication function completes the following functions:

Copying the sewing data compiled by other sewing machine or pattern making software to the operation panel through the USB flash drive;

Copy the sewing data in the operation panel to the USB flash drive.

### 7.1 About data that can be processed

The sewing data that can be processed is as follows:

Data Type	Standard format
VDT	VD00[0-9][0-9][0-9].VDT
sew	ISMS0[0-9][0-9][1-9].sew

### 7.2 Pattern transmission

1. Copy the pattern file from the USB flash drive to the operation panel

In the data input interface, after pressing

the communication button , The communication interface is displayed, as shown on the right.

- 1) Press  this button, it means copy the pattern file from the USB flash drive to the operation panel;

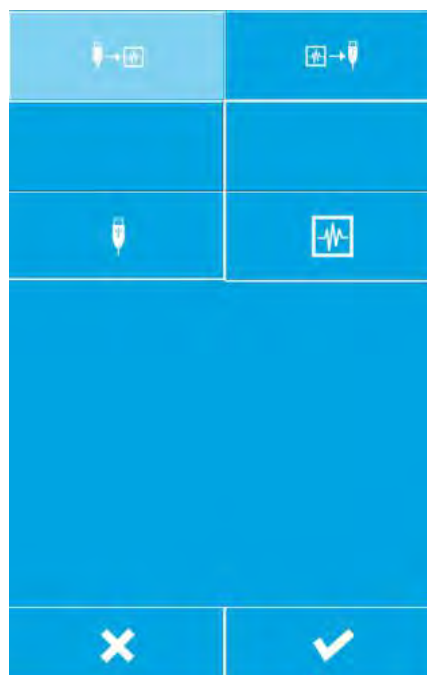

2) Press this button , it shows choose USB files interface, as shown on the right. Find the file you need to copy and press

confirm button.



3) Press the panel button , The input file number interface is displayed, as shown on the right. This file number is the file number after the file is copied to the operation panel. Press the OK button after

entering the file number.

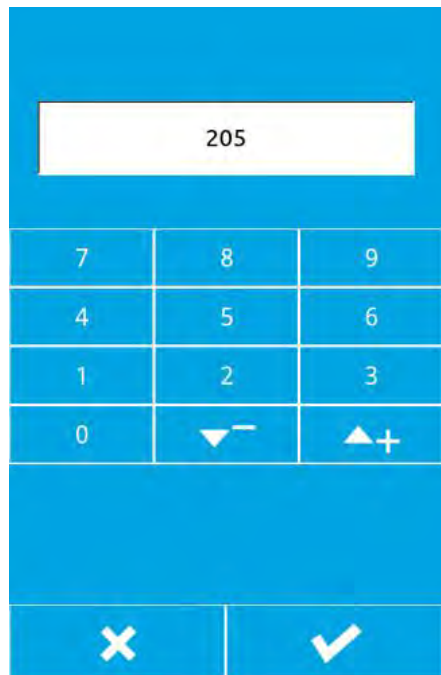

4) After selecting the file from the USB flash drive and entering the operation panel file number, as shown on the right. Press the confirm button , This will copy the files from the USB flash drive to the operation panel.



**2.This will copy the files from the USB flash drive to the operation panel.**

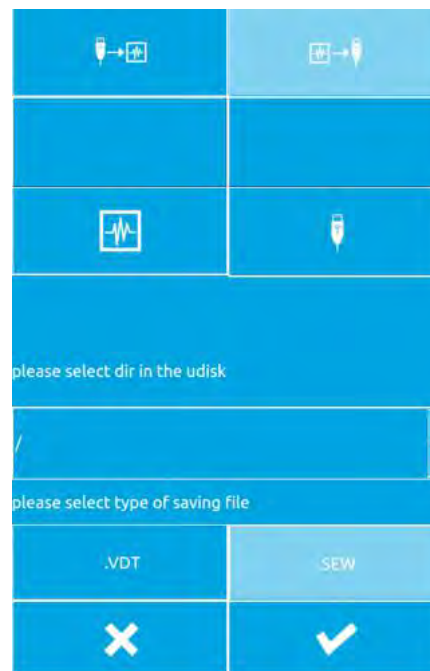

In the data input interface, after pressing the communication button, the communication interface is displayed, as shown in the right figure. 

1) Select the button , this button means to copy the pattern file from the operation panel to the USB flash drive;



2) Press the panel button , The screen for selecting the operation panel file is displayed, as shown on the right. Find the file you want to copy and press the OK button .



3) Press USB button , The input file number interface is displayed, as shown on the right. This file number is the file number after the file is copied to the U disk. After inputting the file number, press the OK button .

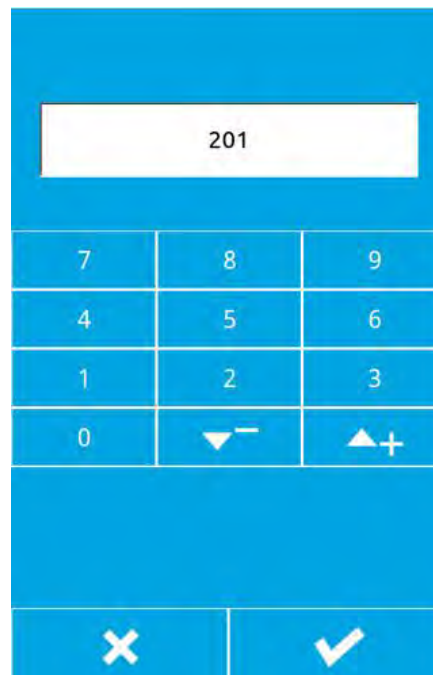

4)After selecting the file from the operation panel and inputting the U disk file number, as shown on the right.Press confirm

button , This will copy the files in the operation panel to the USB flash drive.

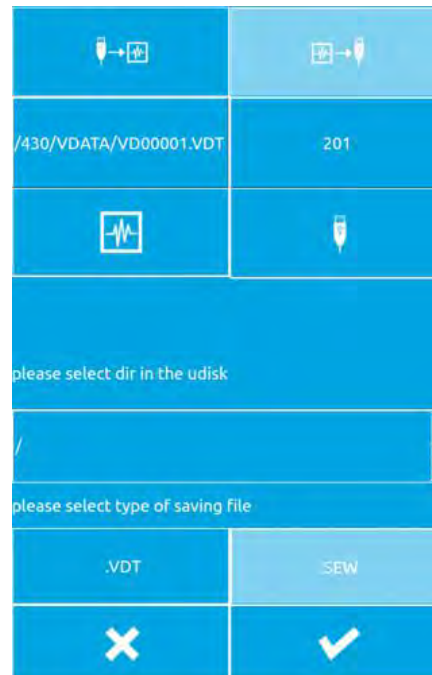

---

## 8 Mode and parameter settings

### 8.1 Mode switching

Press the normal sewing interface



to enter the setting interface (as shown on the right), in which mode switching and setting can be performed.

Three modes: normal seam mode, pattern pattern, and loop stitch mode.

#### Sewing Mode

Press the normal sewing button to enter the normal sewing interface and switch to the normal sewing mode.

#### Design Pattern Mode

Press the pattern play button to enter the pattern making interface, switch to the pattern-making mode, and you can draw the picture, edit the pattern, modify the pattern, etc. in the pattern-making interface.

#### Circle Sewing Mode

Press the cycle sewing button to enter the cycle sewing interface and switch to the cycle mode.

common sew	set parameters
design pattern	auxiliary function
cicle sew	counter
test	about

---

## 8.2 Test

Press the test button to enter the test interface, as shown on the right.

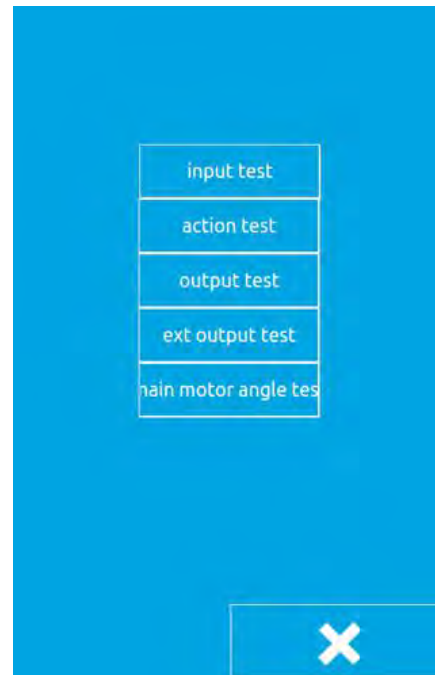

### 8.2.1 Input test

Press the input test button to enter the input test interface. As shown in the figure on the right, you can check the X origin, Y origin, pedal switch, emergency stop switch, and disconnection detection status.



---

## 8.2.2 Action test

Press the action test button to enter the action test interface, as shown on the right. It is possible to test the X-axis movement action, the Y-axis movement action, the trimming action, the intermediate presser action, and the threading action.

 : X axis movement key

 : Y axis movement key

 : Presser foot key

 : Tensioner key

Select the action key to be tested, then click the plus button and minus button. If the corresponding machine component has an action, the action can be executed normally,

and press the button  to close the test.

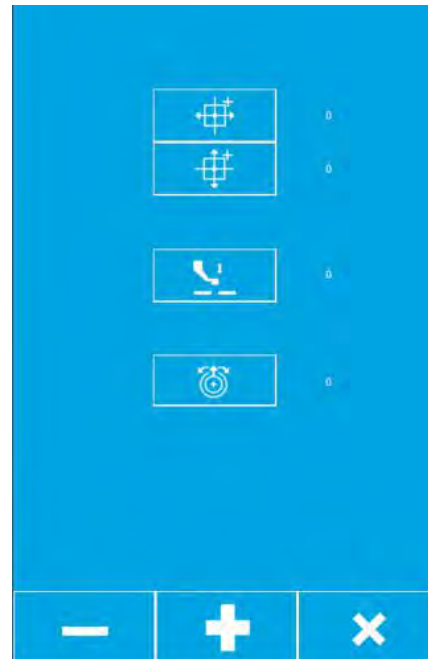

### 8.2.3 Output test

Press the output test button to enter the output test interface. As shown in the figure, after selecting the output port, press the plus or minus button. If the valve of the corresponding output port has action, the output port can work normally. After the test is completed, press the button to

close . 

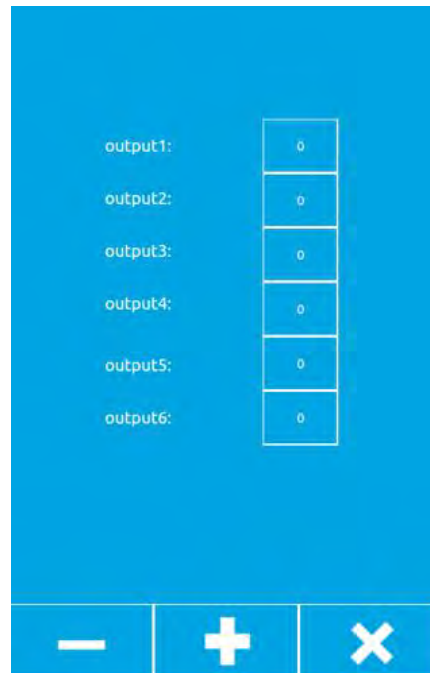

### 8.2.4 External output test

Press the external output test button to enter the external output test interface. As shown in the figure, after selecting the external output port, press the plus and minus keys. If the corresponding external output port of the expansion board has an action, the external output port can be Normal work, press the button to close the

test after the test is completed. 

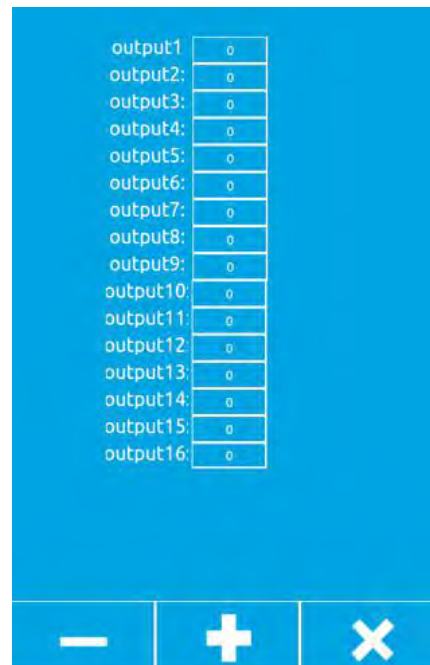

## 8.2.5 Spindle angle test

Press the spindle angle test button to enter the spindle angle test interface. As shown in the figure below, you can view the current spindle angle and rotate the spindle of the machine. The spindle angle will change with the rotation.

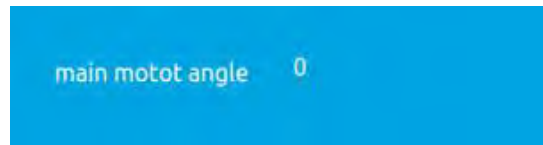

## 8.2.6 Simulate pedal calibration

Press the input test button to enter the input test interface. As shown in the figure on the right, click button A to enter the analog pedal calibration interface.

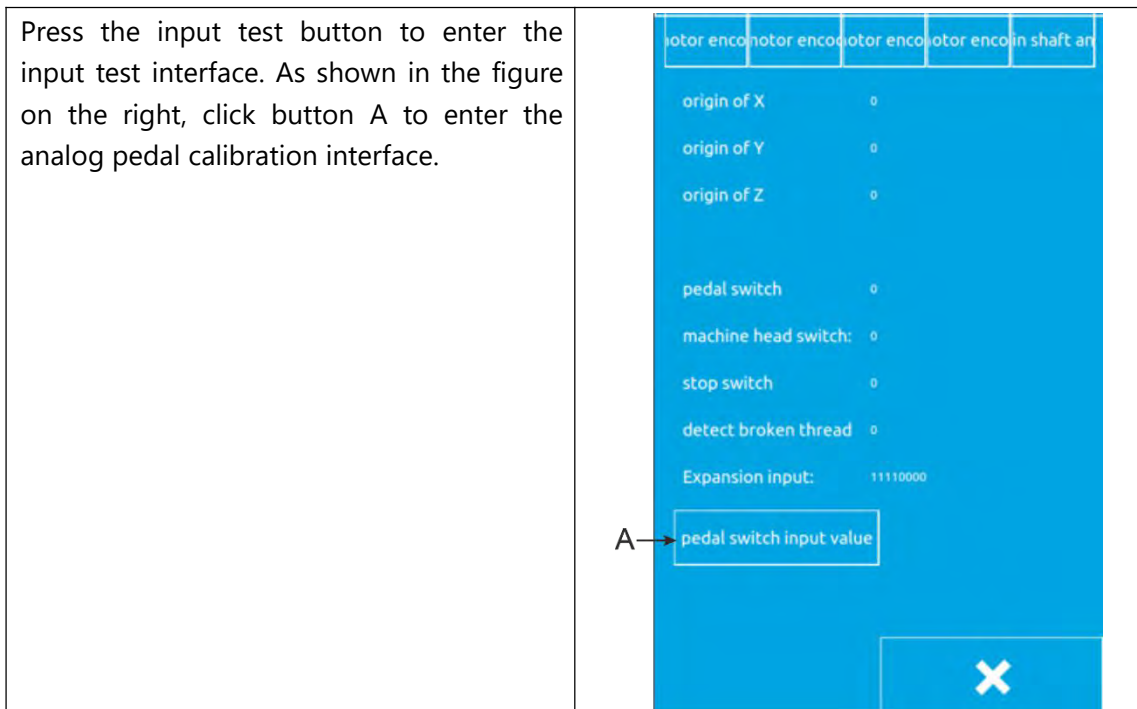

The analog pedal calibration interface is shown on the right.

B: Current pedal pedaling amount

C: The maximum amount of pedals to step on

D: Release the balance position of the pedal

E: The pedal is stepped on by the maximum amount.

Pedal calibration method:

1. Press button C to make it pressed, press the pedal to the maximum amount, press to save the current pedal input value;

2. Press button D to put the button in the pressed state, release the pedal to make the pedal in equilibrium, press again to save the current pedal input value;

3. Button E puts the button in the pressed state, and the pedal reverses the maximum value and presses again to save the current pedal input value.

4. After saving the three pedal input values, the pedal calibration completion button exits the current interface.

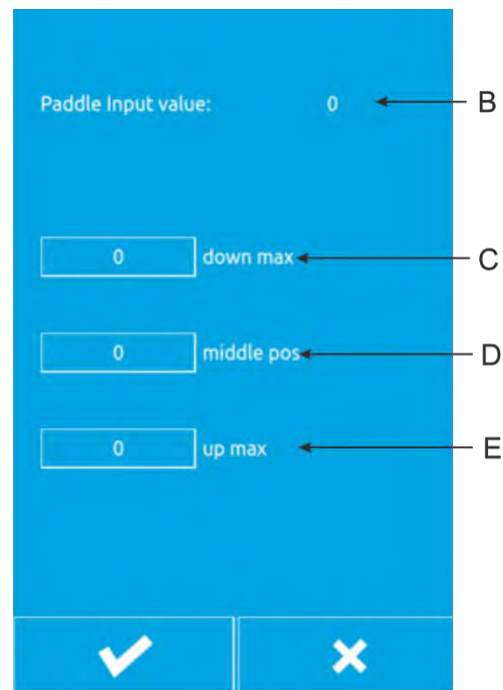





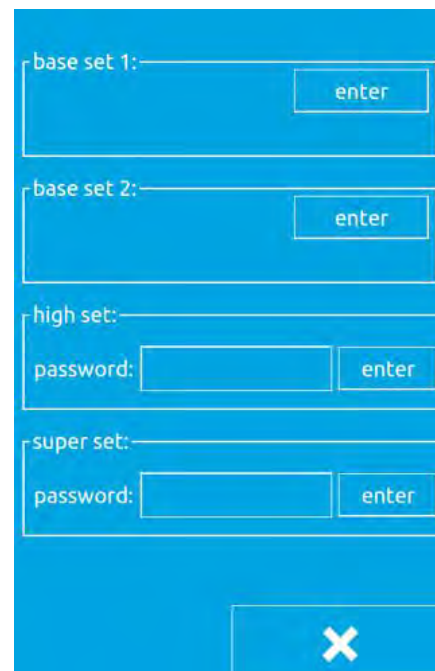

### 8.3 parameter settings

Click the parameter setting button to enter the parameter setting interface, as shown below. The main function of the parameter setting is the setting of some machine parameters and the setting of some options. Among the basic settings 1, some of the more commonly used settings are generally related to the control panel. The settings in the basic settings 2 are generally independent of the control panel. They are only related to the panel. In the advanced settings, some of the more important settings are required. Users with advanced permissions are required. You can set it by entering a password. Super settings are generally only available to factory technicians with super privileges.



### 8.3.1 Basic setting 1

Click the enter button in the basic setting 1 to enter the common basic parameter setting interface, as shown below, through  ,  Press the key to page forward and backward, select the parameter button that needs to be changed, and pass  Key can query the details of the selected parameter and then pass  ,  The key can adjust the value of the parameter, click after setting the parameter value  Key to ensure that the changes take effect, click the  button to exit the common basic parameter setting interface.



The basic settings 1 parameters are described in the following table:

No.	Predetermined area	Initial value	Setting unit	Setting content
1	OFF/1/2	1	-	Frame rise time: After the sewing is completed, the frame rise time OFF: Does not automatically rise 1: rise at the last needle position 2: Move to the beginning of sewing and rise
50	0~12	0	1	Presser foot work mode 0: Standard mode 1-7: reserved 8: One-stage electric pedal 9-11: reserved 12: One-key start
54	0~2	0	1	Dropping time of intermittent presser foot: 0: Linked down by the presser foot switch, but does not drop in the feed retraction position

				1: Linked down by the presser foot switch 2: The presser foot switch is not linked, and the sewing starts to decrease.
70	1~2	1	1	Foot controller switch used 1: foot controller switch (single step) 2: Double linkage foot controller switch (optional)
71	1~2	2	1	1: secondary presser foot is invalid 2: The secondary presser foot is valid
100	ON / OFF	OFF	-	Setting method of slow start mode ON: open OFF: turn off
150	ON / OFF	OFF	-	Reverse needle lift ON: The motor reverses when the upper shaft stops, and the needle bar returns to the uppermost position. [note] When the reverse needle is lifted, the thread take-up lever will rise when the thread take-up will stop at a lower position than usual. Therefore, there is a case where the needle is removed under each sewing condition. OFF: Invalid
151	200~2800 (sti/min)	400	100	The speed at which the sewing starts the first stitch
152	200~2800 (sti/min)	800	100	The speed at which the sewing starts the second stitch
153	200~2800 (sti/min)	1200	100	The speed at which the sewing starts the third stitch
154	200~2800 (sti/min)	1500	100	The speed at which the sewing starts the fourth stitch
155	200~2800 (sti/min)	2000	100	The speed at which the sewing starts the fifth stitch
156	400~2800 (sti/min)	2800	100	The speed at which the sewing starts the fifth stitch
157	400~2800 (sti/min)	2800	100	The speed at which the sewing starts the fifth stitch
158	400~2800 (sti/min)	2800	100	The speed at which the sewing starts the third stitch
159	400~2800 (sti/min)	2400	100	The speed at which the sewing starts the second stitch

163	1200~3200 (sti/min)	2700	100	Sewing speed limit
164	ON / OFF	OFF	-	Prohibit trimming action ON: All trimming actions are invalid OFF: Match the sewing data and trim the thread
260	-80~80	0	1	Change all feeding time
261	-80~80	45	1	Changing the feed time of the first stitch at the start of sewing
262	-80~80	45	1	Changing the feed time of the second stitch at the start of sewing
263	-80~80	45	1	Change the feed time of the 3rd stitch at the start of sewing
264	-80~80	0	1	Changing the feed time of the third stitch at the end of sewing
265	-80~80	35	1	Changing the feed time of the second stitch at the end of sewing
266	-80~80	35	1	Changing the feed time of the first stitch at the end of sewing
268	0~2	1	1	Change all feed time reference
269	0~2	0	1	Change the 3-stitch feed time reference at the start of sewing
462	0~2	0	1	Expand the narrowed reference point 0: Center of the sewing frame (origin) 1: sewing start point 2: pattern center point
471	1~17	14	1	Height of presser foot/button clamp (Electric presser foot only)
472	1~17	6	1	Two-stage presser setting: Set the height of the secondary presser foot in mm.
500	ON/OFF	1	-	Bottom line clamping function setting ON: valid OFF: Invalid
551	OFF/1~3	OFF	-	Sewing start line tension opening OFF: off 1~3: Open within the specified number of stitches

566	ON/OFF	OFF	-	Whether the bottom thread clamping device is installed ON: The bottom thread clamping device is installed OFF: The bottom thread clamping device is not installed. [note] Do not select OFF when installing the bobbin thread clamp. It is easy to cause damage to the device.
582	ON/OFF	OFF	-	Tighten the upper thread tension at the start of sewing ON: invalid OFF: effective
584	-110~40	0	5	At the end of sewing, the upper thread tension opening angle is shifted
585	0-500	255	1	Upper thread tension value at the start of sewing (tightening)
590	200~400	280	40	Cutting speed 200~400sti/min Unit (40sti/min) Initial default value 280sti/min
592	200~700	400	100	Final speed of main motor
962	ON/OFF	OFF	-	Broken wire detection ON: effective OFF: invalid
963	0~1	0	1	0: Manual tensioner 1: Electronic tensioner
964	ON/OFF	OFF	-	Run automatically ON: effective OFF: invalid
965	ON/OFF	OFF	-	Manual thread clamp starts to open ON: effective OFF: invalid
966	0~2	2	1	Dialing method: 0: invalid 1: Electronic 2: Pneumatic.
991	1~9	8	1	Slow start
992	0~1	0	1	Moving frame 0: Move to the starting point after sewing 1: Move to the specified point after

				sewing is completed
996	OFF/ON	OFF	-	Pneumatic presser foot OFF: Electric presser foot ON: Pneumatic presser foot
997	0~2	0	1	0: Left and right presser feet fall at the same time 1: Drop the presser foot from left to right 2: Drop the presser foot from right to left (The valve presser foot is left and right divided presser foot and is operated by double pedal)
999	0~1	0	1	Elastic coefficient
1000	0~6	0	1	Professional setting 0: invalid 5: ready signal 6: Automatically ready signal
2001	0~1	0	1	Moving rigidity

## 8.3.2 Basic setting 2

### 1. Basic settings 2 interface

Click the Enter button in Basic Settings 2 to enter the Basic Settings 2 screen as shown.

### 2. Basic settings 2 function description

#### 1) Restore the super password

If you have forgotten your super password, you can use the recovery super password as the default password. Using this feature requires a password from us to get recovery privileges.

#### 2) Time and date settings

Set the current date and time.

#### 3) Host computer parameter setting

Press the host computer parameter setting button to enter the host computer parameter setting interface, as shown in the figure below.



1) Prompt tone: ON: use the prompt tone, OFF: turn off the prompt tone.

2) The prompt tone uses the default tone: ON: the prompt tone uses the unified default tone, OFF: the prompt tone does not use the unified default tone.

3) Prompt tone type: select the default prompt tone type.

4) Stitch display: ON: the stitch points are displayed in all states during pattern-making; OFF: the stitch points are displayed only when the stitch points are operated during pattern-making.

5) Volume: adjust the volume

6) Stitch color of the boot interface

7) Troubleshooting: open to view error information

8) Special machine selection

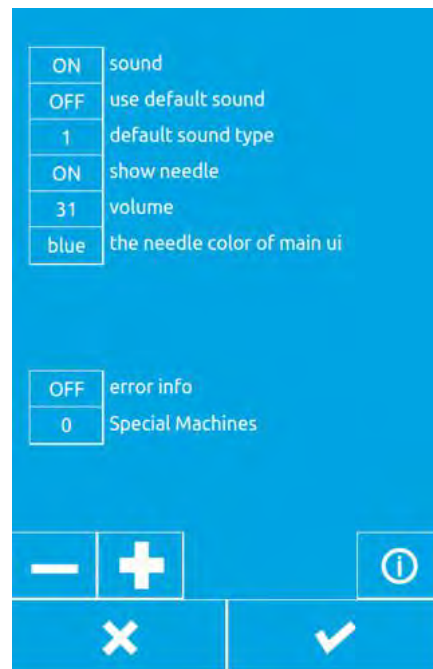

### 8.3.3 Advanced Settings

#### 8.3.3.1 Advanced settings interface

Click the blank space after the password to enter the password. After entering the password, click the Enter button to enter the advanced settings interface, as shown in the figure below. The password setting button can change the password for entering the advanced settings. The parameter setting button can set some advanced parameters. The upper computer upgrade button can upgrade the panel program. The lower computer upgrade button can upgrade the control board program. The factory reset button can restore some parameters of the program to the factory settings. The origin adjustment button can adjust the origin position.

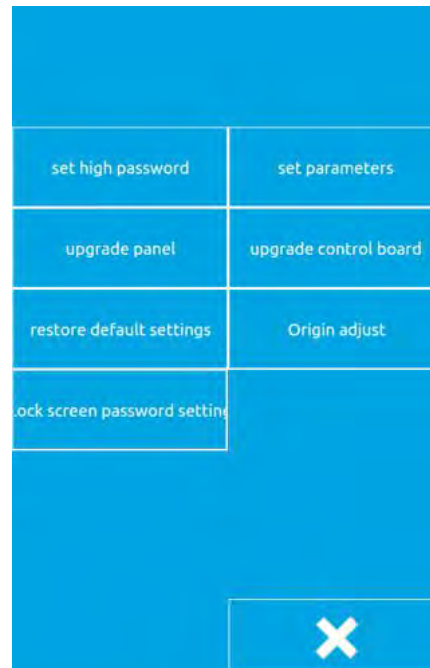

#### 8.3.3.2 Advanced setting parameters

Click the parameter setting button to enter the advanced parameter setting interface as shown.

- (1) Language selection: set Chinese and English.
- (2) Thread trimming angle adjustment: negative value is advanced, positive value is delay (-10 to 10).
- (3) Number of needles for broken thread detection: Set the sensitivity of needle number for broken thread detection.
- (4) Idle feed speed: set the idle feed speed level (1-10), the larger the value, the faster.
- (5) Automatically connect after booting  
ON: Power on automatically connect, enter the pattern confirmation state  
OFF: power on requires manual connection

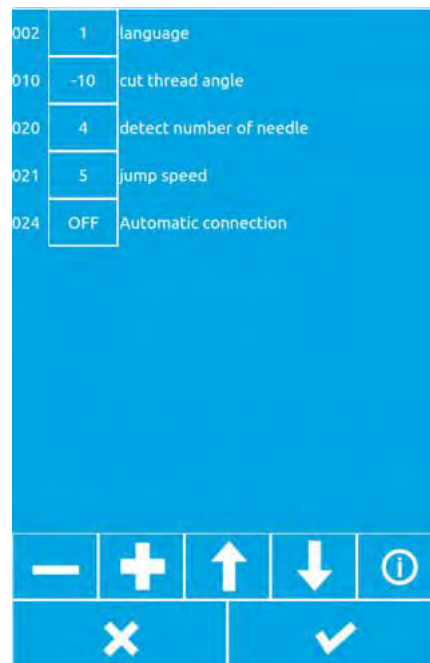

#### 8.3.3.3 Host computer upgrade

This program can upgrade the host computer (panel) through the U disk. Before upgrading, you need to copy the new version of the program panel file and the qm folder

---

to the U disk main directory, then insert the U disk into the panel, and then set the parameters --- >Advanced Settings--->Upper computer upgrades to upgrade the panel program. After the upgrade is successful, the message "Success, please restart" will appear, restart.

### 8.3.3.4 Lower machine upgrade

This program can upgrade the lower computer (control board) through U disk. Before upgrading, you need to copy the new version program (630Q model nc.bin file) (430Q/438Q model STNC430.BIN file) to the U disk main directory. Then insert the U disk into the panel, and then upgrade the control board program through parameter setting ---> advanced settings ---> lower computer upgrade. After the upgrade is successful, the message "Success, please restart" will appear, restart.

### 8.3.3.5 Resetting

This program restores the parameters in Basic Setting 1 to the default values by restoring the factory settings.

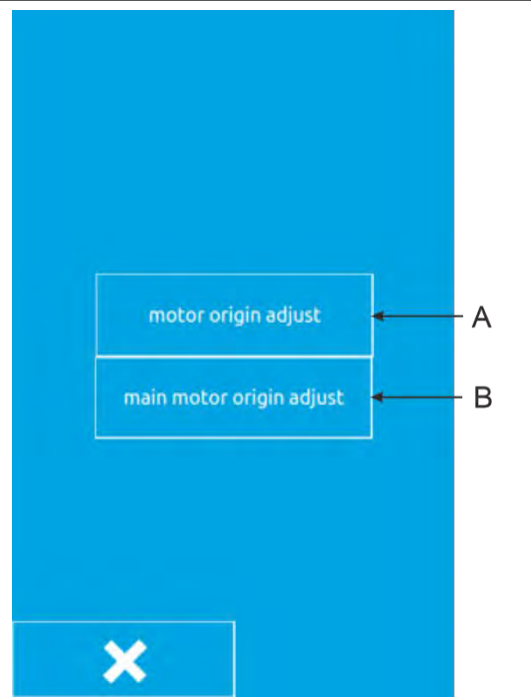

### 8.3.3.6 Origin adjustment

Click the origin adjustment button to enter the origin adjustment interface as shown.



### 1.Motor origin adjustment

Press the A button to enter the motor home position adjustment interface, as shown in the figure, press the 1/2/3 button (to make

the button pressed), press  , 

The key can adjust the origin position of the X/Y/Z motor, and click after the adjustment

is completed.  (The button is

pressed to be lifted), save the current

adjustment value, click  Press to exit.



### 2.Press to exit

Press the B button to enter the spindle origin adjustment interface as shown.

C: current spindle angle display value

(If the displayed value is 65535 or -1, turn the spindle in the direction of the handwheel arrow until the value between 0 and 360 is displayed)

D: parking angle value stored in the head memory

Spindle origin adjustment method: When the spindle display value is between 0 and 360 in the direction of the arrow of the handwheel, stop the needle bar at the stop position and press the D button (to

make the button pressed).Press  Press

the button to save the value displayed in the current C position, that is, the spindle

parking position, press  The key exits.

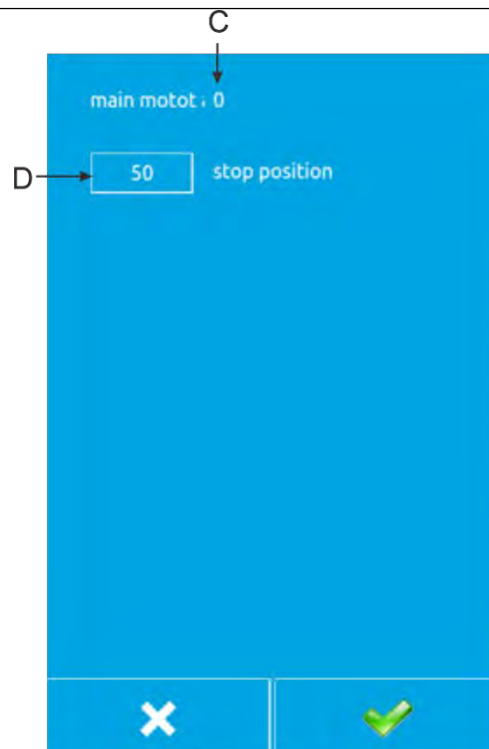

## 8.3.4 Super setting

### 8.3.4.1 Super settings interface

The super setting interface is shown in the figure and set by the manufacturer. Users cannot change it at will. Generally, the parameters in the super setting need to be set before leaving the factory.

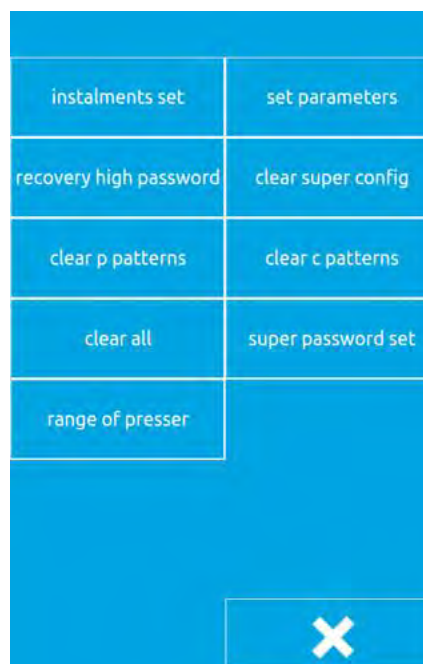

### 8.3.4.2 Super setting parameter

Click the parameter setting button to enter the parameter setting interface of the super parameter, as shown in the figure.

- (1) Machine type: Select the appropriate model according to the machine type.
- (2) Display style: Generally choose the default style.
- (3) Sewing speed limit value: Set the sewing speed maximum value, and the sewing speed will not exceed this value after setting.

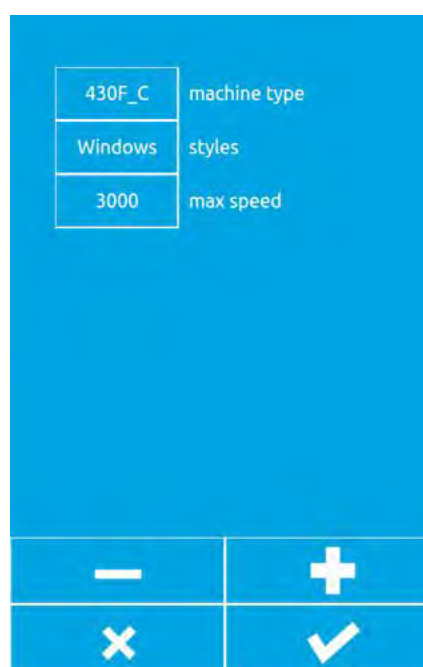

### 8.3.4.3 Installment setting

Press the installment payment button to enter the installment payment interface. Enter the installment payment interface and enter the password to proceed to the next step. For the password, please contact the manufacturer. After entering the password, you can set the

---

panel ID number. After setting the ID number, the machine cannot be sewn. You need to enter the installment password in the advanced settings to sew. Please contact the factory for the installment payment password.

## 8.4 Accessibility

Press the auxiliary function key to enter the auxiliary function interface as shown.

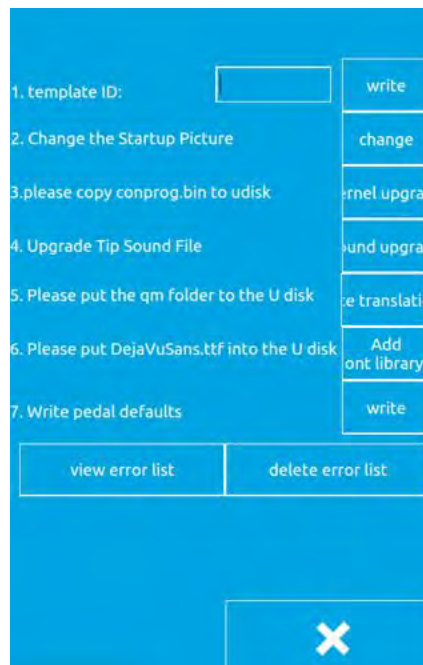

### 8.4.1. Template ID

This function is used to define the template. The template has a wireless identification card. Each card has an ID number, which corresponds to the P pattern number in the panel. When a new wireless identification card template is created or the template ID is changed, the wireless identification card is placed on the template sensor, and then the template ID number is entered in the template ID edit box of the auxiliary function interface, and the "write" is clicked after the input is completed. The button can be used to write the template ID number to the wireless identification card, and the completion of the write will be successful.

### 8.4.2. Change startup image

If you want to change the image displayed when the panel is started, you can send the image you want to display to us, then we will change the image to a file of the specified format and send it to you. You will put the modified image file on the USB flash drive. Insert the USB flash drive into the panel, you can click the "Change" button to change the startup image, and the change will complete the prompt.

### 8.4.3. Kernel upgrade

When you need to upgrade the kernel, we will provide you with the conprog.bin file. You can put this file into the USB flash drive and insert the USB flash drive into the panel. After

---

the panel recognizes the USB flash drive, you can click on the kernel upgrade. The button is upgraded. After the upgrade is completed, the upgrade will be prompted.

#### 8.4.4. Tone tone upgrade

When you need to upgrade the button prompt tone, we will provide the wxaudio folder for you. You put this folder into the USB flash drive and insert the USB flash drive into the panel. After the panel recognizes the USB flash drive, you can click " The prompt tone upgrade button will be upgraded. After the upgrade is completed, the upgrade will be prompted.

#### 8.5 counter

Press the counter button to enter the counter interface, as shown on the right. The sewing counter and the stitch counter mode can be set to set the counter current value and maximum value.

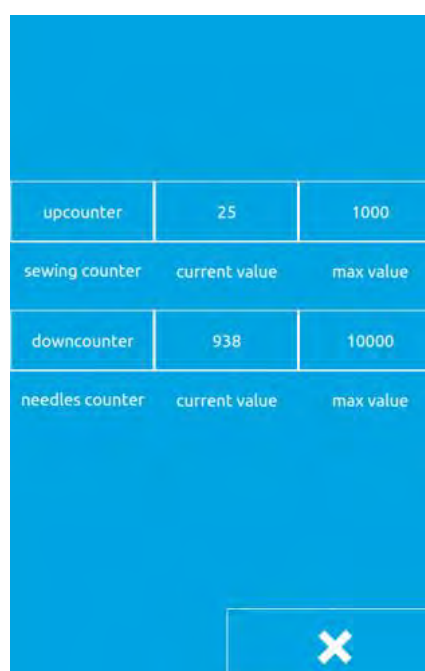

upcounter	25	1000
sewing counter	current value	max value
downcounter	938	10000
needles counter	current value	max value

A white 'X' icon is located in the bottom right corner of the interface.

#### 8.6 Regarding

Press the About button to enter the copyright information inquiry interface, enter the password to view the copyright information.

---

## 9. Appendix 1 Error Table

In the event of a machine failure, the operator panel will display an error code. Please follow the trouble shooting methods in the table below to troubleshoot.

error code	description
10	The emergency stop switch was smashed.press RESET button to eliminate errors.
11	Press Pause the switch.press RESET button to eliminate errors.press Move the presser foot after this key to continue sewing.
12	Press Pause the switch.press After the RESET button is used to cancel the error, step the pedal to the 2nd step and check the origin.
15	When the power is turned on, the emergency stop switch is turned off, but the emergency stop switch is in poor contact. Turn off the power and check the plug of the motherboard socket P9.
16	Poor contact in the emergency stop switch when the power is turned on. Turn off the power and check the plug of the motherboard socket P9.
25	When the power is turned on, the foot pedal switch is stepped on the second gear position. (When the 2-foot pedal switch is the start switch) Turn off the power and check the foot pedal switch.
35	The foot pedal switch is stepped to the first gear position when the power is turned on. (When the 2-foot pedal switch is pressed, the power is turned off) and the foot pedal switch is confirmed.
50	After the power was turned on, the sewing machine head was found to be dumped. Turn off the power and lift the sewing machine head. Confirm the plug of the motherboard socket P14.
51	The sewing machine head was found to be dumped during the sewing machine start-up process. Turn off the power and check the plug of the motherboard socket P14.
55	When the power was turned on, the sewing machine head was found to be dumped. Turn off the power and lift the sewing machine head. Turn off the power and check the plug of the motherboard socket P14.
65	When the power is turned on, the keys on the operation panel are in the state of being squatted, or the keys are not in good contact. Turn off the power and check the operation panel keys.
100	After the “GREASEUP” notification appears, if no grease is added (do not perform the cleaning operation). Add a run, and then perform the action of clearing the work.
111	Incorrect parking position---Turn off the power and check if the thread trimming device or the sewing machine motor is abnormal.
121	Trimming cannot be completed. Turn off the power and check if the blade of the fixed knife or moving knife is scratched or damaged.

130	Main motor failure --- spindle motor failure, or spindle motor controller failure.
131	Poor contact in the sync display. Turn off the power and check that the plug of the motor board's main board P11 is in good condition.
132	It is found that the main motor of the sewing machine is abnormally rotated to cut off the power supply, and it is confirmed that the plug of the motor board main board P11 is in good condition.
133	The sewing main motor stops at a bad position. Turn off the power and check that the plug of the motor board's main board P11 is in good condition.
150	The main motor of the sewing machine is abnormally warmed up or the temperature sensor is not working properly. Turn off the power and check the condition of the sewing machine motor. (If the sewing data is stitched (short cycle) with the number of short stitches (15 stitches) repeatedly, if the upper shaft motor overheats, [E150] may occur.)
200	The origin cannot be found in the X direction --- X motor failure, or Y origin sensor failure
201	The X pulse motor stops abnormally. Turn off the power and check if there is any abnormality in the X feed direction.
203	X motor over current --- X motor failure, or X motor control board failure
204	During the sewing process, the X pulse motor stops abnormally. Turn off the power and check if there is any abnormality in the X feed direction.
205	The X pulse motor stops abnormally during the movement to the sewing start position. Turn off the power and check if there is any abnormality in the X feed direction.
206	During the test transfer, the X pulse motor stops abnormally. Turn off the power and check if there is any abnormality in the X feed direction.
207	Unable to detect X motor motion---Y motor failure, or X motor encoder failure, or X motor control board failure
208	X motor out of control --- X motor encoder failure, or X motor control board failure
210	Y direction can not find the origin - Y motor failure, or Y origin sensor failure
211	The Y pulse motor stops abnormally. Turn off the power and check if there is any abnormality in the Y feed direction.
213	Y motor over current --- Y motor failure, or Y motor control board failure
214	During the sewing process, the Y pulse motor stops abnormally. Turn off the power and check if there is any abnormality in the Y feed direction.
215	The Y pulse motor stops abnormally during the movement to the sewing start position. Turn off the power and check if there is any abnormality in the Y feed direction.
216	During the test transfer, the Y pulse motor stops abnormally. Turn off the power and check if there is any abnormality in the Y feed direction.
217	Unable to detect Y motor motion---Y motor fault, or Y motor encoder fault, or Y motor control board fault
218	Y motor out of control---Y motor encoder failure, or Y motor control board failure
300	The trimming motor can't find the origin---trimming motor fault, or the trimming

	motor encoder is faulty.
301	It is not possible to detect the rise and fall of the presser foot/button clamp. Turn off the power and check if there is any abnormality in the up and down direction of the presser foot/button clamp.
303	Trimming motor overcurrent---trimming motor failure, or trimming motor control board failure
307	Unable to detect electric motion of trimming motor---trimming motor fault, or trimming motor encoder fault, or trimming motor control board fault
308	The trimming motor is out of control---the trimming motor encoder is faulty, or the trimming motor control board is faulty.
320	The wire grabbing motor can't find the origin - catch the wire motor fault, or catch the wire motor encoder fault
321	Catch the line motor over current --- catch the line motor failure, or catch the line motor control board failure
323	Unable to detect the electric movement of the wire grab motor---catch the motor fault, or catch the line motor encoder fault, or catch the line motor control board fault
324	The line grab motor is out of control---catch the line motor encoder failure, or the line grab motor control board is faulty.
400	When the power is connected, the connection communication error between the main board and the main board of the control board is detected. Turn off the power and check that the socket P1 of the control board main board and the socket P3 of the motor main board are in good condition.
401	When the power is connected, the link communication error between the main board and the motor main board is detected. Turn off the power and check that the plug P5 of the main board and the plug P2 of the motor main board are in good condition.
410	A communication error between the main board and the main board of the control board was detected. Turn off the power and plug it in again.
411	A communication error has been detected between the motherboard and the motor board. Turn off the power and plug it in again.
420	The storage tool is not inserted. Press RESET button to eliminate errors.
421	The data content is incorrect and cannot be used, or there is no data. press RESET button to eliminate errors. Confirm whether the data of the model serial number is stored in the storage tool.
422	An error occurred while reading the storage tool information. Press RESET button to eliminate errors. Confirm the data in the storage tool.
424	There is not enough space in the storage tool. press RESET button to eliminate errors. Use other storage tools.
425	An error occurred while writing to the storage tool. Press RESET button to eliminate errors. Please use the specified storage tool. Check if writing is prohibited or if there is room.
427	The style registered in the loop program is deleted. press RESET button to eliminate errors. Re-register the loop program and add the style.
428	The style set in the program is deleted. press RESET button to eliminate errors.

	Reset the program and add a pattern.
430	Data cannot be backed up to the motherboard. Turn off the power and reconnect the power.
440	The CPU PCB data storage is abnormal. Turn off the power and reconnect the power.
450	The model selection information cannot be read from the head storage device. Turn off the power and check that the plug of the power supply main board P16 is in good condition.
451	Data cannot be stored in the head memory. Turn off the power and reconnect the power.
452	Unable to connect to the head storage device. Turn off the power and check if the plug of the main board's P16 is in good condition.
480	Template position sensor exception
500	After making the enlarged setting, the sewing data exceeds the area where sewing is possible. press RESET button to eliminate errors. Set the magnification or sewing area again.
502	After making the enlarged setting, the data pitch exceeds the maximum pitch of 12.7 mm.press RESET button to eliminate errors. Set the magnification again.
510	The program data is abnormal.press RESET button to eliminate errors. Re-read program data from the storage tool or re-program the data.
511	The completion code cannot be entered into the program data. Press RESET button to eliminate errors. Redo the program data of the input completion code, or change the serial number of the read program.
512	More than the number of stitches that can be used.press RESET button to eliminate errors. Change the serial number of the reader.
581	The storage switch folder could not be read correctly. The model before copying and the model after copying are incorrect. (The data of 438Q has the possibility of reading to 430Q) press RESET button to eliminate the error. Please read the data of the same model.
582	The versions of the memory switches are inconsistent. Press RESET button to eliminate errors. Please read the same version of the data.
583	The version of the parameter does not match. Press RESET button to eliminate errors. Please read the same version of the data.
600	A facial line break occurred. press RESET button to eliminate errors. Move the KEY_STEP_BACK button moves the presser foot to continue sewing.
690	The medium-pressure foot motor cannot find the origin---the medium-pressure foot motor is faulty, or the medium-pressure foot motor encoder is faulty.
691	The bottom thread clamping motor stops abnormally. Check if the excess line is too long. Turn off the power and remove the flying velvet at the bottom of the needle plate. Check if the plugs of the sockets P20 and P4 of the main board are in good condition.
693	Intermediate presser motor overcurrent---Medium presser foot motor failure, or medium presser foot motor control board failure
697	Cannot detect the electric motion of the medium-pressure foot motor---the

	medium-pressure foot motor is faulty, or the medium-pressure foot motor encoder is faulty, or the medium-pressure foot motor control board is faulty.
698	The medium-pressure foot motor is out of control---the medium-pressure foot motor encoder is faulty, or the medium-pressure foot motor control board is faulty.
700	The power supply voltage has risen abnormally. Turn off the power and check the input voltage.
701	The main motor drive voltage of the sewing machine has risen abnormally. Turn off the power and confirm the voltage
705	The power supply voltage drops abnormally. Turn off the power and check the input voltage.
710	The sewing main motor detects an abnormal current. Turn off the power and check if the sewing machine is abnormal.
711	The pulse motor detects an abnormal current. Turn off the power and check if the presser/button clamp is operating abnormally.
720	The head cannot be down
721	The head cannot be raised
820	Pattern queue empty
821	Pattern no end code
822	No stop code
830	Pattern data overflow
850	CAN bus response error
901	X motor pulse error (internal error)
902	Y motor pulse error (internal error)
903	Trimming motor pulse error (internal error)
904	Middle presser motor pulse error (internal error)
905	Traction motor pulse error (internal error)
906	internal error
911	internal error
912	internal error
913	internal error
914	internal error



高林股份有限公司  
KAULIN MFG. CO., LTD.

由於對產品的改良及更新，本產品零件圖及外觀的修改恕不事先通知！  
The specification and/or appearances of the equipment described in this parts list are  
subject to change because of modification which will without previous notice.  
CQL-02X02.APR.2024