

# SIRUBA

電控參數說明書

ELECTRONIC CONTROL PARAMETER MANUAL

■ LKS-1900D Series



# 前言

歡迎您使用本公司的特種縫紉機控制系統。

請您仔細閱讀本操作手冊，以確保正確的操作、使用特種縫紉機，請按照本手冊內注明的方式進行操作，否則，如違規操作所造成損失本公司不承擔責任。此外，請將本用戶手冊妥善保存在安全地點，以便隨時查閱。若發生故障須由本公司指定的技術人員或專業人員進行維修。

## Foreword





Thank you for using our Computerized Control System for Special Sewing Machine.

It is appreciated that you do read this manual carefully in order to operate the machine correctly and effectively. If the user operates the machine contrary to regulations herein, thus cause loss to user or third party, we will not take responsibility. Besides, you should keep this manual for future use. For any fault or problem of machine, please ask the professionals or the technicians authorized by us for repair service.



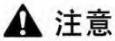





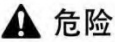

# 安全注意事項

## 1. 安全操作的標誌及含義

本使用說明書及產品所使用的安全標誌是為了讓您正確安全的使用產品，防止您及其他人受到傷害。標誌的圖案和含義如下：

	危險	如果忽視此標記而進行錯誤的操作，會導致人員的重傷或死亡。
	注意	如果忽視此標記而進行錯誤的操作，會導致人員的受傷和設備的損壞。
		該符號表示“應注意事項”。三角中的圖案表示必須要注意的內容。（例如左邊的圖案表示：“當心受傷”）
		該符號表示“禁止”
		該符號表示“必須”。圓圈中的圖案表示必須要做的內容。（例如左邊的圖案表示“必須接地”）

## 2. 安全注意事項





 危險	
	打開控制箱時，先關閉電源開關並將電源插頭從插座上拔下後，等待至少 5 分鐘後，再打開控制箱蓋。觸摸帶有高電壓的區域會造成人員受傷。
 注意	
使用環境	
	應避免在強電氣干擾源（如高頻焊機）的附近使用本縫紉機。 強電氣干擾源可能會影響縫紉機的正常操作。
	電源電壓的波動應該在額定電壓的±10%以內的環境下使用。 電壓大幅度的波動會影響縫紉機的正常操作，需配備穩壓器。
	環境溫度應在 0°C~45°C 的範圍內使用。 低溫或高溫會影響縫紉機的正常操作。
	相對濕度應在 35%~85% 的範圍內，並且設備內不會形成結露的環境下使用。乾燥、潮濕或結露的環境會影響縫紉機的正常操作。
	壓縮空氣的供氣量應大於縫紉機所要求的總耗氣量。壓縮空氣的供氣量不足會導致縫紉機的動作不正常。
	萬一發生雷電暴風雨時，關閉電源開關，並將電源插頭從插座上拔下。雷電可能會影響縫紉機的正常操作。
安裝	
	請讓受過培訓的技術人員來安裝縫紉機。
	安裝完成前，請不要連接電源。 如果誤按啟動開關，縫紉機動作會導致受傷。

	縫紉機頭倒下或豎起時，請用雙手操作。不要用力壓縫紉機。 如縫紉機失去平衡，縫紉機滑落到地上會造成受傷或機器損壞。
	必須接地。 接駁地線不牢固，是造成觸電或誤動作的原因。
	所有電纜應固定在離活動部件至少 25mm 以外處。另外，不要過度彎曲或用卡釘固定得過緊。 會引起火災或觸電的危險。
	請在機頭上安裝安全罩殼。
<b>縫紉</b>	
	本縫紉機僅限於接受過安全操作培訓的人員使用。
	本縫紉機不能用於除縫紉外的任何用途。
	使用縫紉機時必須戴上保護眼鏡。 如果不戴保護眼鏡，斷針時機針折斷部分可能會彈入眼睛造成傷害。
	發生下列情況時，請立即切斷電源。否則誤按下啟動開關時，會導致受傷。 1.機針穿線時      2.更換機針時      3.縫紉機不使用或人離開縫紉機時
	縫紉過程中，不要觸摸任何運動部件或將物件靠在運動部件上，因為這會導致人員受傷或縫紉機損壞。
	如果縫紉機操作中發生誤動作，或聽到異常的雜訊或聞到異常的氣味，應立即切斷電源。然後請與購買商店或受過培訓的技術人員聯繫。
	如果縫紉機出現故障，請與購買商店或受過培訓的技術人員聯繫。
<b>維護和檢查</b>	
	只有經過訓練的技術人員才能進行縫紉機的維修、保養和檢查。
	與電氣有關的維修、保養和檢查請及時與電控廠家的專業人員進行聯繫。
	發生下列情況時，請關閉電源並拔下電源插頭。否則誤按啟動開關時，會導致受傷。 1.檢查、調整和維修      2.更換彎針、切刀等易損零部件
	在檢查、調整和修理任何使用氣動設備之前，請先斷開氣源，並等壓力錶指標下降到“0”為止。
	在必須接上電源開關和氣源開關進行調整時，務必十分小心遵守所有的安全注意事項。
	未經授權而對縫紉機進行改裝而引起的縫紉機損壞不在保修範圍內。









## SafetyMattersforAttention

















### 3. Signs&Definitions of SafetyMarks





This OperationManual andthe Safety Marks printed on the products are to enable you to use this product correctly so as to be away from personal injury.The signs and definitions of Marks are shown in below:

 Danger	Theincorrectoperationduetonegligencewillcausetheseriouspersonalinjuryorevendeth.
 Caution	Theincorrectoperationduetonegligencewillcausethepersonalinjuryandthedamageofmechanism.
	Thiskindofmarkis “MattersforAttention” ,andthefigureinsidethetriangleisthecontentfor attention.(Exp.Theleftfigureis “WatchYourHand!” )
	Thiskindofmarkis “Forbidden” .
	Thiskindofmarkmeans “Must” .Thefigureinthecircleisthe contentsthat havetobedone.(Exp. Theleftfigureis “Ground!” )

### 4. SafetyMattersforAttention

 <b>Danger</b> Danger	
	Foropeningthecontrolbox,pleaseturnoffthepowerandtakeawaytheplugfromsocketfirstly, andthenwaitforatleast5minutesbeforeopeningthecontrolbox.Touchingthepartwithhigh voltage will cause the person injury.
 <b>Caution</b> Caution	
<b>UsageEnvironment</b>	
	Trynottousethissewingmachinenearthesourcesofstrongdisturbancelikehigh-frequency welding machine. Thesourceofstrongdisturbancewillaffectthenormaloperationofthesewingmachine.
	Thevoltagefluctuationshallbewithin10%oftheratedvoltage. The large fluctuation of voltage will affect the normal operations of sewing machine, Therefore avoltage regulator is needed in that situation.
	Workingtemperature:0°C~45°C. The operation of the sewing machine will be affected by environment with temperature beyond the above range.
	RelativeHumidity:35%~85%(Nodewinsidethemachine),ortheoperationofsewingmachinewill beaffected.
	Thesupplyofcompressedgasshallbeovertheconsumptionrequiredbythesewingmachine.The insufficientsupplyofcompressedgaswillleadtotheabnormalactionofsewingmachine.

	In case of thunder, lightning or storm, please turn off the power and pull plug out the socket. Because these will have influence on the operation of sewing machine.
<b>Installation</b>	
	Please ask the trained technician to install these sewing machine.
	Don't connect machine to power supply until the installation is finished. Otherwise the action of sewing machine may cause personal injury once the start switch is pressed at that situation by mistake.
	When you tilt or erect the head of sewing machine, please use both of your hand in that operation. And never press the sewing machine with strength. If the sewing machine loses its balance, it will fall into floor thus cause the personal injury or mechanical damage.
	Grounding is a must. If the grounding cable is not fixed, it may cause the electric-shock and mis-operation of machine
	The entire cable shall be fixed with a distance at 25mm away from the moving component at least. By the way, don't excessively bend or tightly fixed the cable with nails or clamps, or it may cause the fire or electric shock.
	Please add security cover on the machine head.
<b>Sewing</b>	
	This sewing machine can only be used by the trained staff.
	This sewing machine has no other usages but the sewing.
	When operating these sewing machine, please remember to put on the glasses. Otherwise, the broken needle will cause the personal injury in case the needle is broken.
	At following circumstances, please cut off the power at once so as to avoid the personal injury caused by the mis-operation of start switch: 1. Threading on needles; 2. Replacement of needles; 3. The sewing machine is left unused or beyond supervision
	At working, don't touch or lean anything on the moving components, because both of the above behaviors will cause the personal injury or the damage of these sewing machine.
	During working, if the mis-operation happens or the abnormal noise or smell is found at the sewing machine, users shall cut off the power at once, and then contact the trained technicians or the supplier of that machine for solution.
	For any trouble, please contact the trained technicians or the supplier of that machine.
<b>Maintenance &amp; Inspection</b>	
	Only can the trained technicians perform the repair, maintenance and inspection of this sewing machine.
	For the repair, maintenance and inspection of the electrical component, please contact the professionals at the manufacturer of control system in time.

	<p>At following circumstances, please cut off the power and pull off the plug at once so as to avoid the personal injury caused by the mis-operation of start switch.</p> <ol style="list-style-type: none"> <li>1. Repair, adjustment and inspection ;</li> <li>2. Replacement of the component like curved needle, knife and soon</li> </ol>
	<p>Before the inspection, adjustment or repair of any gas-driven devices, users shall cut off the gas supply till the pressure indicator fall to 0.</p>
	<p>When adjusting the devices needing the power supply and gas supply, users can't be too careful to follow the entire Safety Matters for Attention.</p>
	<p>If the sewing machine damages due to the unauthorized modification, our company will not be responsible for it.</p>

# 目錄

1 概要說明.....	1
1900D技術參數表.....	1
應用機型.....	2
輸入方式.....	2
顯示方式.....	2
面板佈局.....	2
標準化.....	2
操作方式.....	2
2 操作及調試.....	3
控制台圖示及說明.....	3
主軸馬達的安裝.....	4
系統檢測模式（調試模式）.....	4
01系統輸入檢測.....	5
02XY原點校正.....	5
03老化模式.....	6
04主軸檢測.....	7
06壓腳電機檢測.....	7
08系統輸出檢測.....	8
09面板檢測.....	8
基本操作.....	8
圖案編號的設定.....	8
專案資料的設定.....	8
圖案形狀的確認.....	10
縫製.....	11
向其他圖案的變更.....	11
捲繞底線.....	11
使用計數器的縫製.....	12
踏板急停功能.....	13
設置P花樣與C花樣.....	14
使用圖案鍵進行縫製.....	14
使用組合功能（迴圈縫製）的縫製.....	16
複製/刪除P花樣和C花樣.....	17
複製/刪除P花樣.....	17
複製/刪除C花樣.....	18
記憶體開關的啟動和變更.....	18
用戶參數設置表.....	19
3 服務參數設置.....	22
服務參數的開啟和變更.....	22
服務參數清單.....	22
恢復出廠默認設置.....	24
軟體版本顯示.....	24
查看運行總針數和清除加潤滑油報警資訊.....	24
使用者密碼設置及系統U/K參數鎖定.....	25
修改使用者密碼.....	25

設置系統U/K參數鎖.....	25
4 釘扣功能.....	27
釘扣功能設定.....	27
5 通過U盤升級花樣.....	28
花樣升級操作.....	28
6 附錄1.....	30
1900A套結機花樣一覽表.....	30
釘扣機花樣一覽表.....	34
1906A套結花樣一覽表.....	35
主控異常資訊一覽表.....	38
面板異常資訊一覽表.....	43
7 附錄2.....	46
電控箱安裝尺寸.....	47
操作箱安裝尺寸.....	46
控制箱外部線纜連接.....	48
系統框圖.....	48
1 General Information    51	
Technical Parameters of 1900D.....	51
Corresponding Machine Type.....	52
Input Mode.....	52
Display Method.....	52
Panel Layout.....	52
Standardization.....	52
Operation Mode.....	52
2 Operation and Debugging.....	53
Instructions of Operation Panel.....	53
Installing the Main Shaft Motor.....	54
Text Mode.....	54
01 System Input Test.....	55
02 XY Origin Adjustment.....	55
03 Aging Mode.....	56
04 Main Shaft Detection.....	57
06 Presser Foot Motor Detection.....	57
08 System Output Test.....	58
09 Panel Test.....	58
Basic Operations.....	59
Pattern Number Setting.....	59
Item Data Setting.....	59
Pattern Shape Confirmation.....	60
Sewing.....	61
Change to Other Pattern.....	61
Bobbin Thread Winding.....	62
Sewing with Counter.....	62

Pause.....	64
PPatternandCPatternSetting.....	65
UsePatternKeytoSew.....	65
GroupSewing(CyclicSewing).....	66
Copy/DeletePPatternandCPattern.....	68
Copy/DeletePPattern.....	68
Copy/DelectCPattern.....	69
MemorySwitchActivationandChange .....	69
UserParameterSettingList.....	70
3 ServiceParameterSetting.....	72
ServiceParameterActivationandChange.....	72
ServiceParameterList.....	73
RestoreDefaultSetting .....	76
SoftwareVersionDisplay .....	76
CheckTotalNumberofStitchesandClearLubricatingAlarm.....	76
PasswordSettingandU/KParameterLock .....	77
ChangePassword.....	77
SetU/KParameterLock.....	77
4 ButtonSewingFunction.....	79
ButtonSewingFunctionSetting.....	79
5 UpdatePatternDatabyUSBDisk.....	80
PatternDataUpdate.....	80
6 Appendix1 .....	82
ListofPatternsin1900AController.....	82
ListofPatternsforButton-sewingin1900BController .....	86
ListofPatternsforDoublingController.....	86
MainControlError List.....	90
OperationPanelError List.....	96
7 Appendix2.....	99
InstallationSizeofControlBox.....	100
InstallationSizeofOperationPanel.....	99
ExternalCableConnectionofControlBox.....	101
SystemDiagram.....	101

# 1 概要說明

1900D技術參數表

No.	機 型 項 目	1900D
1	用途	套結、釘扣
2	縫製範圍	X(左右) 方向 40mm× Y(前後) 方向 30mm
3	最高縫紉速度	最高 3300rpm (MSC是 3000rpm)
4	縫跡長度	0.1mm – 10.0mm (0.1mm單位)
5	送布	間接送布(脈衝馬達 2軸驅動方式)
6	針杆行程	41.2mm
7	機針	DP×5#14(DP×5 #11(F,M), (DP×17#21厚料))
8	抬壓腳方式	脈衝馬達
9	壓腳上升量	標準 14mm,最大 17mm(反轉抬針時)
10	標準花樣數	100個
11	撥線方式	脈衝馬達抬壓腳連動
12	抓線裝置	標準：通常 0
13	麵線張力	電子夾線器
14	旋梭	半旋轉標準旋梭或半旋轉倍旋梭
15	加油方式	旋轉部：微量加油
16	機油	縫紉機油
17	潤滑脂	縫紉機用潤滑脂
18	資料記憶	FlashMemory
19	放大縮小功能	X方向、Y方向各自獨立縮放 20%~200% ( 1%單位 )
20	放大縮小方式	線跡長度增減方式
21	縫製速度限制	400-3300rpm(100rpm單位)
22	花樣選擇功能	花樣號碼指定方式(1-200)
23	底線記數	上轉/下轉方式(0 – 999999)
24	機械馬達	500W小型 AC伺服馬達(直接驅動方式)
25	外形尺寸	305mm×223mm×80mm
26	控制箱重量	約為 10Kg
27	額定功率	600W
28	使用溫度範圍	0°C-45°C
29	使用濕度範圍	35% - 85% ( 無結露 )
30	電源電壓	AC220V±10% ; 50/60Hz

最高縫製速度請根據縫製條件降低速度使用

產品執行標準：QCYXDK0004—2022《工業縫紉機電腦控制系統》。

## 應用機型

電子套結(加固)釘扣機。

## 輸入方式

採用按鍵輸入方式。

## 顯示方式

採用黑白點陣液晶屏和發光二極體顯示方式。

## 面板佈局

操作面板整體為長方形，分為兩部分，顯示部分為 1 個點陣液晶屏和 2 個發光二極體，操作部分為 17 個按鍵。參考操作說明控制台圖。

## 標準化

功能按鍵採用業界公認的圖形標識，圖形是國際化語言，各國使用者都可以識別。

## 操作方式

功能鍵包括準備鍵，重定鍵，模式鍵，穿線/繞線鍵、選擇鍵、加減鍵、編輯按鍵、返回鍵以及特殊功能鍵等。具體操作方法請參考第 2 節“操作說明”。

## 2 操作及調試

### 控制台圖示及說明

#### (1) 液晶顯示幕

顯示圖案編號、形狀等各種資料。

#### (2) 準備鍵

控制台的設定程式設計狀態和縫紉機實際動作的縫製狀態的變換鍵。

#### (3) 復位鍵

解除異常、將設定值返回到初期值時使用。

#### (4) 模式鍵

設置參數或存儲花樣的開關鍵。

#### (5) 壓腳卷線鍵

提升、下降壓腳。上升時，把針杆移動到原點；下降時，把針杆移動到右側。在繞線時按。

#### (6) 項目選擇鍵

切換選擇不同圖案類型、功能表項目或參數。

#### (7) 數據變更鍵

修改圖案編號或參數值，在試縫模式中單針移動送布。

#### (8) 編輯按鍵

顯示編輯畫面，選擇專案，或者顯示詳細畫面。

#### (9) 返回鍵

返回前一個畫面。

#### (10) 直接圖案 (P 花樣)

登記 P 花樣。登記後的圖案，只要一按此鍵就可以立即選擇進行縫紉。

#### (11) 計數器鍵

在縫紉模式編輯 (未準備) 狀態下，按下後可以直接進入計數器設置模式。

#### (12) 特殊功能鍵

根據設置按下後實現特殊功能。

#### (13) 特殊功能 LED

進入特殊功能後 LED 點亮。

#### (14) 縫製準備 LED 縫

製模式時點亮。

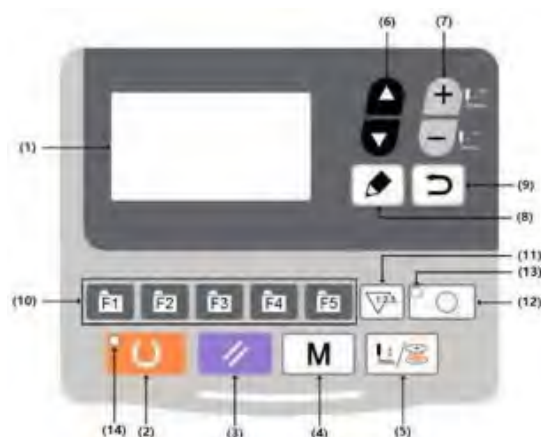

## 主軸馬達的安裝

主軸馬達通過連接器 連接到縫紉機的上軸上，馬達連接器由 4 個螺絲分別固定到縫紉機上軸及馬達主軸上。首先，將連接器第 1 螺絲 垂直於縫紉機上軸平面擰緊，然後擰緊連接器第 2 螺絲 ；連接器第 3 螺絲 垂直於馬達主軸平面擰緊，然後擰緊連接器第 4 螺絲 ，這樣完成了主軸馬達與縫紉機上軸的連接。安裝圖示如圖：

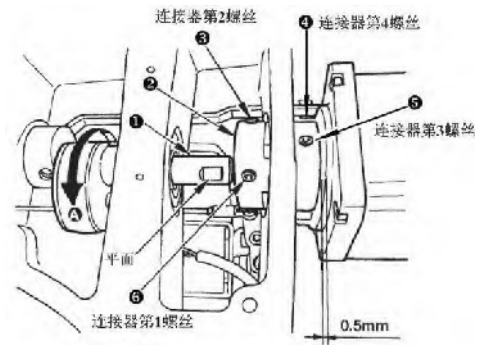

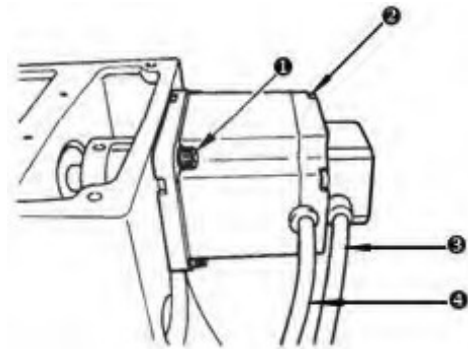

主軸馬達的外部線纜朝向（從縫紉機後部向前部看去，電機線纜朝向觀察者的左手邊），安裝位置如圖所示：

為主軸馬達安裝固定螺絲，共有 4 個； 為主軸馬達後殼固定螺絲，共 4 個；  
為主軸馬達編碼器信號線； 為主軸馬達電源線。





## 系統檢測模式（調試模式）

通過啟動該模式，可進行保養檢查操作。



- 1) 在縫製燈熄滅的狀態下，按住模式鍵 **M** 持續 3 秒，面板蜂鳴器會鳴響一聲，然後按項目選擇鍵  選中“11 系統檢測”，再按編輯按鍵  可以進入調試模式。





- 2) 按項目選擇鍵  可以變更功能測試程項目，按編輯按鍵  進入測試項目，每個序號代表的功能如下表所示：

功能測試項目	功能	內容
01系統輸入檢測	輸入信號檢驗	以燈亮提示開關，感測器輸入的狀態。
02XY原點校正	XY馬達/原點感測器檢驗	顯示 X/Y馬達寸動操作，原點檢索操作以及 X/Y 原點傳感器的狀態
03老化模式	連續運轉	在設定連續運轉條件後，移向連續運轉模式。
04主軸檢測	主馬達旋轉數檢驗	設定旋轉數、機器啟動、顯示實測旋轉數。
06壓腳電機檢測	壓腳、切線馬達/原點感測器檢驗	顯示壓腳、切線馬達寸動操作，原點檢索操作，以及壓腳原點/壓腳感測器的狀態。
08系統輸出檢測	輸出信號檢驗	驅動輸出電磁鐵/氣閥動作。

09面板檢測	檢測LED與LCD	檢測面板顯示幕和 LED燈是否,正常。
--------	-----------	---------------------







- 3) 各功能測試如果按返回鍵  或模式鍵  的話，就會終止測試，返回到2)的狀態；但是，如果使用過老化模式 1 次的話，就不能解除了，只有關閉電源才能結束。

### 01系統輸入檢測

<p>1) 能夠檢驗操作控制盤鍵、踏板開關、各種感測器等的輸入狀態。在選中“01系統輸入檢測”時，按編輯按鍵  進入。</p> <p>在該模式中，按專案選擇鍵  切換輸入檢測專案，而檢測信號的狀態在螢幕右側顯示。</p>	
--	--

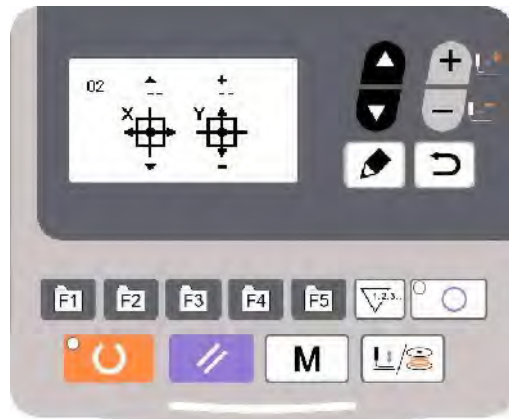

### 02XY原點校正

顯示XY馬達的寸動操作，原點檢索操作以及 X/Y原點感測器的狀態。

<p>1) XY電機單步運行測試</p> <p>如果在開機後從未按過準備鍵  進入準備狀態，而是直接按模式鍵  進入系統功能表的系統檢測模式，則進入該“02XY原點校正”模式後可以直接按專案選擇鍵  和數據變更鍵  分別對XY電機進行單步移動。如果在開機後按準備鍵  進入過準備狀態，則每次進入該“02XY原點校正”模式後必須先按一次復位鍵  執行XY原點檢索後才能單步移動電機，而此時表示的是XY電機原點校正功能。</p> <p>在移動XY電機的過程中，如果原點感測器信號發生變化，螢幕顯示的圖示會改變為反色顯示。</p>	
---	---

## 2) XY電機原點校正

先按一次復位鍵執行XY原點檢索，螢幕上會顯示出X電機的原點感測器狀態A和當前校正值C，以及Y電機的原點感測器狀態B和當前校正值D。

按項目選擇鍵和數據變更鍵分別對XY電機進行單步移動，同時校正值也會隨之改變，觀察壓腳正中與機針針孔位置重合後，按準備

鍵保存校正值並返回。如果修改後但不想

保存校正值，需要按返回鍵或模式鍵

放棄保存並返回。

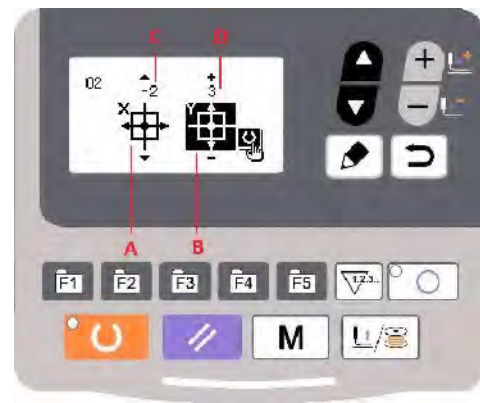

## 03老化模式

在選中“03老化模式”時，按編輯按鍵進入連續運轉模式。在設定了連續運轉條件後，啟動連續運轉模式；如果要解除連續運轉模式請關閉電源。

### 1) 間隔時間的設定

在顯示“(01)老化間隔”時，按數據變更鍵, 設定兩次運轉的間隔時間。

從0至9900ms可以100ms為單位進行設定。  
(默認值2000ms)。



### 2) 縫製結束有無原點檢索的設定。

按項目選擇鍵鍵切換到顯示“(02)原點檢索”，設定縫製結束時有無原點檢索。

OFF：無效(預設值)

ON：有效(每次縫製結束後進行原點檢索)

設定完成後，按準備鍵保存設置，並進入普通縫製模式主介面。

### 3) 連續操作



在普通花樣縫製模式下，使用者可以設定花樣號碼、X、Y縮放率、最高轉速等條件然後開始縫製。縫製結束之後，如果在第2步操作中設定有原點檢索的話，則開始進行X/Y壓腳、切線/抓線的各個馬達的原點檢索；在經過設定的時間間隔後再次自動開始進行縫製；如果要中止連續縫製，請在縫紉停止時，

按準備鍵停止。







若要終止繼續縫製，請關閉電源。

## 04主軸檢測

設定機器的轉速，在設定的轉速下僅驅動機器的主馬達，顯示實測的轉速。

<p>1) 準備</p> <p>在選中“04主軸檢測”時，按編輯按鍵進入該模式，各個電機自動執行原點檢索，螢幕上會顯示出主軸電機的“目標轉速”、“實際轉速”和“主軸角度”。</p>	
---	--

### 2) 操作

按數據變更鍵，可以變更設定主軸的目標轉速，然後按準備鍵，機器以設定的轉速開始運轉。如需再次變更設定轉速，可以在運轉過程中繼續使用資料變更鍵設定轉速值，然後按準備鍵，機器以新設定的轉速運轉。如需停止運轉，按復位鍵。如需退出該模式，請在機器停止運轉的情況下，按返回鍵或模式鍵。

## 06壓腳電機檢測



顯示壓腳、切線馬達的寸動操作，原點檢索操作以及壓腳原點感測器和切線感測器的狀態。

<p>1) 壓腳電機運行測試</p> <p>類似【2.3.202XY原點校正】模式中的操作，在上電後沒有進入過準備狀態的情況下，進入“06壓腳電機檢測”模式後，可以直接按資料變更鍵對壓腳電機執行單步移動測試，螢幕上會顯示壓腳原點剪刀位置兩感測器信號狀態。而一旦執行了原點檢索，每次進入該模式後，必須先踩踏板到2檔執行原點檢索，之後才能移動電機。</p>	
<p>2) 壓腳電機位置模擬運行測試</p> <p>在該模式中踩踏板到2檔執行原點檢索後，可以按編輯按鍵讓電機在抬起、降下等幾個工作位置模擬運行。</p>	

### 3) 壓腳電機原點校正



在該模式中踩踏板到 2 檔執行原點檢索後，不按編輯按鍵  讓電機保持在原點位置 A 狀態

下，按數據變更鍵  可以修改當前原點校正值 D，同時壓腳原點感測器信號 B 和剪刀位置感測器信號 D 也會根據實際狀態顯示變化。修

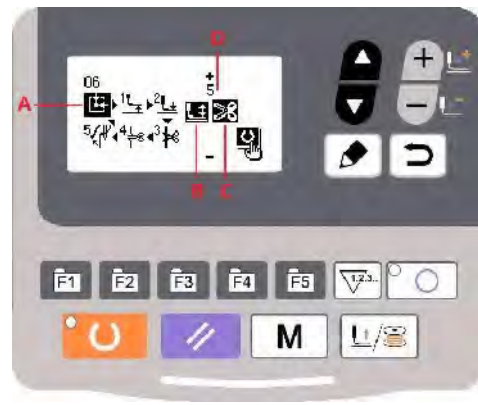

改好是設置數值後，按準備鍵  保存校正值並返回。如果修改後但不想保存校正值，需要按返回鍵  或模式鍵  放棄保存並返回。



## 08系統輸出檢測

在該模式下，可以通過按項目選擇鍵  鍵切換要檢測的設備，按編輯按鍵  驅動設備動作。

## 09面板檢測

在該模式下，可以通過按編輯按鍵  點亮面板上的所有LED燈，並讓LCD液晶屏全屏顯示，再次按編輯按鍵  返回正常顯示狀態。

## 基本操作

### 圖案編號的設定

打開電源開關。

在畫面的左上方圖案 No. 被顯示，圖案形狀、X/Y 放大縮小率、線張力值、縫製速度也被顯示出來。

按了數據變更鍵  之後，可以變更圖案No.。按項



目選擇鍵  進行花樣模式切換；即：內置花樣、P 型花樣和 C 型迴圈花樣。



### 專案資料的設定

按了編輯按鍵  之後，專案資料登錄畫面被顯示出來。

在畫面的左側顯示出可以編輯的專案，在畫面右側顯示出設定內容。

用項目選擇鍵  選擇專案，然後可以用資料變更鍵  變更設定內容，按  退出後自動保存。

### (1) X尺寸的輸入

請按項目選擇鍵 ，顯示出C001X尺寸。

請按數據變更鍵 ，顯示出希望的數值。

X、Y的尺寸輸入，用記憶體開關 U063輸入%或者從實際尺寸值進行選擇。（預設值：%輸入）

注意：設定超出壓板允許縫製範圍時，機針和布壓腳會相碰，發生斷針，非常危險。



### (2) Y尺寸的輸入

請按項目選擇鍵 ，顯示出C002Y尺寸。

請按數據變更鍵 ，顯示出希望的數值。

X、Y的尺寸輸入，用記憶體開關 U063輸入%或者從實際尺寸值進行選擇。（預設值：%輸入）

注意：設定超出壓板允許縫製範圍時，機針和布壓腳會相碰，發生斷針，非常危險。



### (3) 縫製速度的輸入

請按項目選擇鍵 ，顯示出C004縫製速度。

請按數據變更鍵 ，顯示出希望的數值。

輸入的最大範圍是記憶體開關 U001 最高縫製速度的數值。



### (4) 線張力的設定

請按項目選擇鍵 ，顯示出C003線張力。

請按數據變更鍵 ，顯示出希望的數值。（輸入範圍：0~200）

確定後，請用返回鍵  返回到輸入畫面。

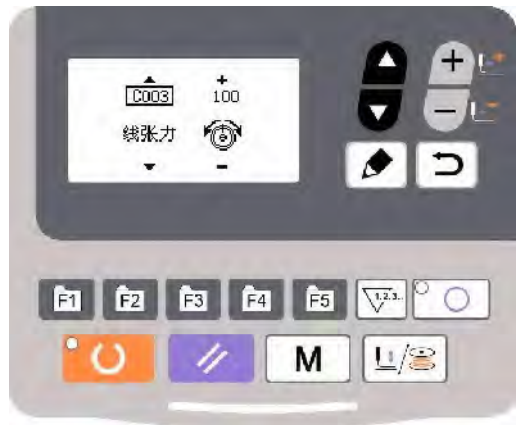

## (5) 設定結束

按準備鍵 。

壓腳移動→上升後準備鍵 LED指示燈點亮，成為可以縫製的狀態。

注意：按準備鍵壓腳進行回花樣起縫點過程中，壓腳首先下降然後再移動，因此請注意不要夾到手指。

\* 按準備鍵  之後，圖案No.、XY擴大縮小率等設定值被記憶。

\* 再按次準備鍵  之後，準備鍵LED指示燈熄滅。可以變更各項目的設定。

\* 請確認了圖案No.之後再使用。顯示著圖案No.的狀態下按了準備鍵  之後，會顯示M-306異常錯誤。此時，請重新設定圖案 No.。

注意：不按準備鍵  開關，關掉電源後，圖案No.、XY 擴大縮小率、最高轉速、線張力的設定值均不能被記憶。

### 圖案形狀的確認

警告！



1. 選擇圖案後，請一定確認圖案的形狀。如果圖案遠離壓腳，縫製途中機針會碰到壓腳，弄斷機針。
2. 確認圖案形狀時，請注意如果在針杆下降後的狀態下按了+/-鍵的話，針杆將自動地復位到上位置之後壓腳才移動。

<p>1) 按準備鍵 ，準備鍵LED指示燈點亮。</p> <p>2) 按壓腳卷線鍵 ，顯示出「壓腳下降畫面」。</p> <p>3) 用+鍵  顯示出形狀確認畫面。</p> <p>在此模式下，踩踏了踏板縫紉機不會執行縫製動作。</p>	
<p>4) 請用數據變更鍵  確認花樣是否在壓板範圍內。</p> <p>5) 用復位鍵 ，返回到縫製開始位置，壓腳上升。</p> <p>如按返回鍵  之後，在現在的位置的狀態下顯示縫製畫面。</p> <p>在此狀態下，踩踏了踏板之後，可以從現在的位置進行縫製。</p>	

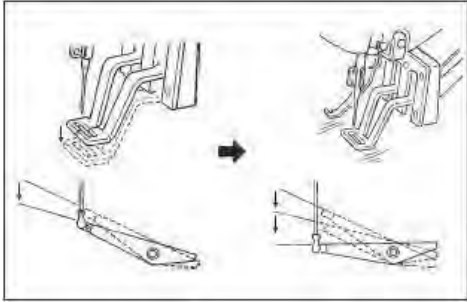
## 縫製

<p><b>縫製：</b></p> <ol style="list-style-type: none"><li>1. 把縫製品放到壓腳部。</li><li>2. 踩踏板開關至第一級，壓腳下降；鬆開踏板後，壓腳上升。</li><li>3. 踩踏板開關至第二級之後開始縫製。</li><li>4. 縫製結束後，壓腳上升返回到起始縫的位置。</li></ol>	
---	--

## 向其他圖案的變更

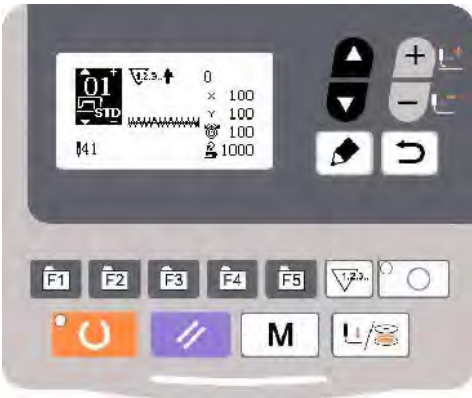
<p>按準備鍵 ，準備鍵LED指示燈熄滅。</p> <p>用數據變更鍵  設定圖案No。</p> <p>與【2.4.2專案資料的設定】同樣，可以設定XY放大縮小率、速度等。</p> <p>按了準備鍵  之後，準備鍵LED指示燈點亮，變成可以縫製的狀態。</p> <p>選擇圖案後，請一定確認圖案的形狀。 萬一圖案遠離壓腳，縫製途中機針會碰到壓腳，弄斷機針。</p>	
---	---

## 捲繞底線



<ol style="list-style-type: none"><li>1) 按準備鍵 ，準備鍵LED指示燈熄滅。</li><li>2) 按壓腳卷線鍵 ，選擇下降壓腳。</li><li>3) 按▼鍵 ，顯示卷線畫面。</li><li>4) 踩踏踏板之後，縫紉機轉動。</li></ol>	
<ol style="list-style-type: none"><li>5) 再次踩踏板或者按了復位鍵  之後，縫紉機停止。</li><li>6) 按了準備鍵 、返回鍵  之後，結束卷線畫面。</li></ol> <p>注意：剛剛打開（ON）電源後，卷線不動作。請設定1次圖案No.等，按  鍵進行原點檢索之後再進行操作。</p>	

## 使用計數器的縫製

### (6) 計數器值的設定方法

<p>1) 進入計數器設定畫面 在準備鍵 LED 指示燈熄滅的輸入模式，按模式鍵 <b>M</b>，顯示出模式畫面。</p> <p>用項目選擇鍵 ，把「02 計數器設定」設定為選擇狀態。</p> <p>按編輯按鍵 ，顯示計數器畫面 A。</p> <p>或在準備鍵 LED 指示燈熄滅的輸入模式，按計數器鍵  也可以直接進入計數器畫面 A。</p> <p>計數器畫面 A 被顯示，成為可以設定。計數器值的設定只能用輸入模式進行設定。如果是縫制模式時，請按準備鍵 ，準備鍵 LED 指示燈熄滅的狀態下。</p> <p>2) 計數器類別的選擇 按項目選擇鍵 ，反轉表示計數器類別的圖標 B。按數據變更鍵 ，從下列計數器類別中選擇適當的計數器。</p>	 
<p>3) 計數器設定值的變更 按項目選擇鍵 ，反轉計數器設定值 C。按數據變更鍵 ，輸入設定值（目標值）。</p> <p>4) 計數器現在值的變更 按項目選擇鍵 ，反轉計數器現在值 D。按復位鍵  之後，可以清除計數器途中的值。另外，用資料變更鍵  也可以進行數值編輯（當前值）。</p>	

### (7) 計數器類別

-  B01 縫製加數計數器  
每進行 1 形狀的縫製之後，現在值數位加 1。  
現在值和設定計數器
-  B02 縫製減數計數器  
每進行 1 形狀的縫製之後，現在值數字減 1。  
現在值到達 0 之後，顯示出減數計數器畫面。
-  B03 件數加數計數器

加算計數進行 1 個迴圈縫的各個現在值。現在值和設定值相等之後，顯示出加數計數器畫面。

 B04 件數減數計數器

減算計數進行 1 個迴圈縫的各個現在值。現在值到達 0 之後，顯示出減數計數器畫面。

 B05 底線加數計數器

每縫製 10 針，在現在值的基礎上進行加算。現在值和設定值相等之後，顯示計數器加數畫面。

 B06 底線減數計數器

每縫製 10 針，在現在值的基礎上進行減算。現在值等於 0 之後，顯示計數器加數畫面。

 B07 不使用計數器



### (8) 計數器加數的解除方法

縫製作業中如果到達加數條件之後，則顯示出加數畫面。按復位鍵  之後，複位元數目器，返回縫製模式。而且，開始再記數。





### 踏板急停功能

腳踏板分為三檔：1 檔壓腳下降；2 檔正常縫製；3 檔（腳跟向後反踩）為急停檔。

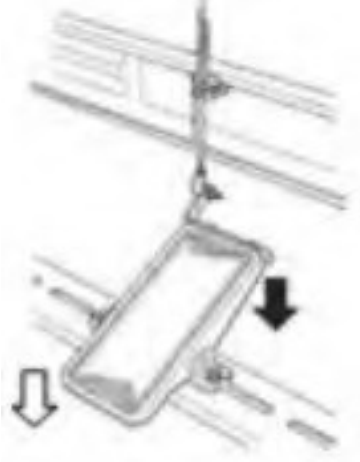
- 1) 按下準備鍵後向前  踩腳踏板，壓腳下降；
- 2) 再次向前  踩腳踏板便開始縫製；
- 3) 在縫製過程中，如果需要急停，您可以向後  踩一下腳踏板，機器進入急停，面板顯示“E-002”。



### (9) 面板急停



- 1) 用記憶體開關 U031 把重定鍵設定為 1 之後，復位鍵變成暫停鍵，縫製中可以用來停止縫紉機。
- 2) 用復位鍵  讓縫紉機停止，E-002 被顯示出來。按了復位鍵  之後，解除異常，前進後退送布畫面被顯示出來。



3) 解除後的操作有以下 3 種

1. 用開始開關重新開始縫製。

2. 按復位鍵 ，進行切線後，用資料變更鍵  調整位置，然後再用開始開關開始縫製。

3. 按復位鍵 ，進行切線後，再次按復位鍵  複歸原點。

4. 按復位鍵進行切線後，再次踩踏板可繼續進行縫製。

### 設置 P 花樣與 C 花樣

#### 使用圖案鍵進行縫製



可以把已經登記的圖案 (No.1~200) 登記到 P1~P99 上。變更擴大縮小率、最高轉速限制、線張力、縫製位置就可以登記，用圖案 No. 的滾動視窗選擇同樣可以登記圖案，可以一次地叫出 P1~P25。

\*選擇了 P6~P25 時，用下表所示的  鍵的組合 (同時按) 進行縫製。



P-No.	選擇鍵	P-No.	選擇鍵	P-No.	選擇鍵	P-No.	選擇鍵
P1	P1	P8	P1+P4	P15	P4+P5	P22	P2+P3+P4
P2	P2	P9	P1+P5	P16	P1+P2+P3	P23	P2+P3+P5
P3	P3	P10	P2+P3	P17	P1+P2+P4	P24	P2+P4+P5
P4	P4	P11	P2+P4	P18	P1+P2+P5	P25	P3+P4+P5
P5	P5	P12	P2+P5	P19	P1+P3+P4		
P6	P1+P2	P13	P3+P4	P20	P1+P3+P5		
P7	P1+P3	P14	P3+P5	P21	P1+P4+P5		

#### (1) 往圖案鍵上的登記



設定例：把圖案 No.3、X 擴大縮小 50%、最高速度限制 2,000sti/min、線張力 “50”、圖案位置右移 0.5mm、前移 1mm 的設定登記到 P2。



- 1) 打開 (ON) 電源，然後按模式鍵 **M**。(準備完了 LED 應該滅燈) 進入方式設定 (記憶體開關設定)。按項目選擇鍵 ，把「04 登記 P 花樣」設定為選擇狀態。按編輯按鍵 ，顯示圖案登記模式。





- 2) 按項目選擇鍵 ，把標準圖案設定為No.3。按數據變更鍵 ，把 P-No. 設定為 2。按了準備鍵之後，P2 被登記，模式畫面被顯示出來。按模式鍵 **M** 或者按返回鍵 。

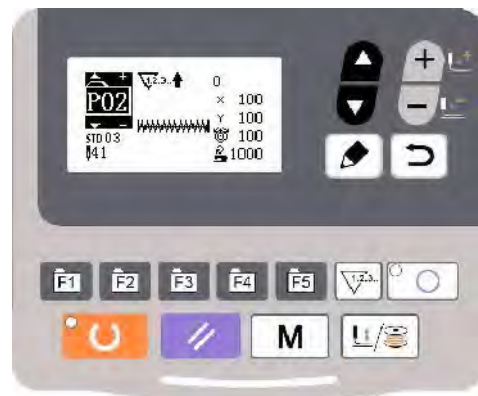

- 3) 按編輯按鍵 ，然後請用資料變更鍵  進行專案資料的編輯。

- 4) 分別進行設定，把 X 尺寸縮小率設定為「50 %」，把 Y 尺寸縮小率設定為「80 %」，把縫製速度設定為「2000」sti/min，把線張力設定為「50」。
- 5) 按了編輯按鍵  之後，「X 放大縮小率」顯示為 0.0。可以用 0.1mm 單位來設定 X 方向的移動量。用數據變更鍵  把數據變更為「0.5」。



- 6) 按了編輯按鍵  之後，「Y 放大縮小率」顯示為 0.0。可以用 0.1mm 單位來設定 Y 方向的移動量。用數據變更鍵  把數據變更為「-1.0」。

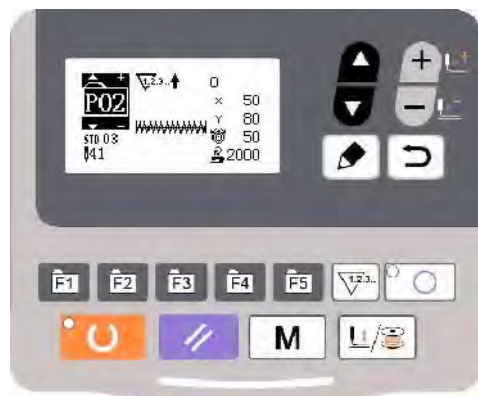

- 7) 按準備鍵  之後，設定結束。

- 8) 按模式鍵 **M**。結束圖案登記方式。

- 9) 按模式鍵 **M**。結束方式設定，返回通常方式。



## 使用組合功能（迴圈縫製）的縫製

本縫紉機可以順次地縫製複數的迴圈縫製圖案資料。

最多可以輸入 99個圖案，縫製具有多個不同的圖案的縫製物時可以使用。

另外，最多還可以登記 99個資料。需要時，請拷貝之後使用。

### (1) 迴圈資料的選擇

- 1) 設定為輸入模式  
在準備鍵 LED 指示燈熄滅輸入模式下，可以選擇連續縫製資料。縫製模式時，請按準備鍵  變換為輸入模式。僅資料模式時，可以選擇連續縫製資料。
- 2) 選擇迴圈縫製資料  
按項目選擇鍵  順序在已登記的圖案之間進行切換，顯示被登記的迴圈資料 No.、連續縫製資料 No.。這時，請選擇想縫製的迴圈資料 No.。





### 3) 進行縫製

在連續縫製資料被選擇的狀態下，按了準備鍵  之後，準備完了 LED 亮燈，變成可以縫製。

購買時僅登記了迴圈資料 No.1，沒有輸入縫製圖案，不能成為縫製狀態。因此，請參照下頁（2）迴圈資料的編輯方法進行輸入。



### (2) 迴圈縫資料的編輯方法

- 1) 設定為輸入模式  
在準備完了 LED 滅燈的輸入模式下，可以輸入連續縫製資料。縫製模式時，請按準備鍵  變換為輸入模式。
- 2) 把迴圈縫資料設定為編輯狀態  
按了編輯按鍵  之後，進入編輯狀態，當前選中編輯點的圖案 No. 變為反色顯示。此狀態可以編輯資料。



### 3) 選擇編輯點

按了項目選擇鍵  之後，當前選中編輯點順次切換，在移動到最後一個圖案之後，顯示出追加圖示。

在編輯點選擇中，按了編輯按鍵  之後，在選擇位置追加指示圖示  被顯示，此時可以插入圖案資料。

### 4) 變更選擇的編輯要點的資料

按數據變更鍵  之後，可以變更編輯要點的資料。

被登記的圖案 No.被顯示出來，可以進行選擇。



另外，按復位鍵後，可以刪除編輯點的圖案資料。

請反覆步驟 3、步驟 4 進行資料編輯。

### 5) 取消圖案資料的插入

按了返回鍵之後，取消圖案資料的插入，移動到輸入模式。

## (3) 縫製操作



- 1) 打開 (ON) 電源。
- 2) 用項目選擇鍵選擇循環圖表案，然後用資料變更鍵選擇循環圖表案No.。
- 3) 按準備鍵，準備鍵LED指示燈點亮之後，壓腳移動，然後上升。







### 複製/刪除P花樣和C花樣

可以將已經登記的 P花樣複製為新的 P花樣，C花樣也可以複製。也可以將已經存在的 P花樣或 C花樣刪除（但如果只剩下最後一個 C 花樣，這個 C 花樣是不可以刪除的）。



### 複製/刪除P花樣

- 1) 在縫製燈熄滅的狀態下，按模式鍵進入系統功能表，按專案選擇鍵選中“05複製/刪除P 花樣”，再按編輯按鍵進入該模式。









- 2) 用項目選擇鍵切換被複製（已經存在）的P花樣號，用變更數據鍵切換要新複製（尚未存在）的 P花樣號。確定好後，按準備鍵執行保存操作並返回。如果想要放棄修改，按返回鍵不保存返回。



3) 在使用變更資料鍵  切換要新複製的P花樣號時，可以選中刪除圖示 ，如果此時按準備鍵 ，將會刪除已經存在的P花樣。





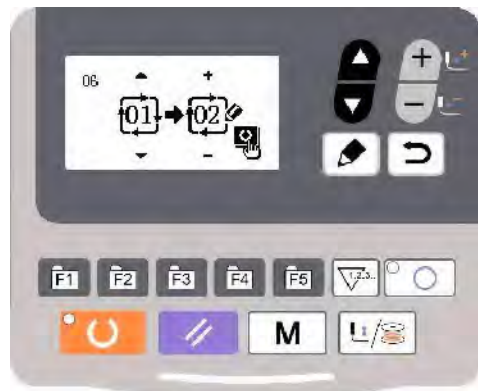

### 複製/刪除 C花樣

- 1) 在系統功能表中，按專案選擇鍵  選中“06 複製/刪除C花樣”，再按編輯按鍵  進入該模式。
- 2) 類似 P花樣的複製/刪除操作，可以使用變更資料鍵  切換新的C花樣號執行複製操作，選擇  表示刪除C花樣，使用項目選擇鍵  切換為  圖示時，表示登記一個新的空 C 花樣。



### 記憶體開關的啟動和變更

- 1) 設定輸入模式  
在準備鍵 LED 指示燈熄滅的輸入模式下，可以變更記憶體開關資料。縫製模式時，請按準備鍵  變換為輸入模式。
- 2) 進入記憶體開關資料編輯畫面  
按了模式鍵  之後，模式畫面（操作人員等級）被顯示出來。  
按項目選擇鍵 ，選擇「01系統U參數」。  
按了編輯按鍵  之後，變成存儲器開關資料畫面。



3) 選擇變更的記憶體開關資料

按項目選擇鍵，選擇想變更的資料項目。

4) 變更數據

用變更數據鍵，可以增減變更設定值。

5) 保存並退出

在執行完資料變更操作後，按返回鍵保存修改並退出該模式回到模式畫面，再按返回鍵回到縫製畫面。



### 用戶參數設置表

參數號	功能	調整範圍	初值	備註
U001	縫製的最高速度。 (可以以 100rpm 為單位設定)	400~3000	3000	
U002	第 1 針的縫製速度。(抓線) (可以以 100rpm 為單位設定)	400~1500	1500	
U003	第 2 針的縫製速度。(抓線) (可以以 100rpm 為單位設定)	400~3000	3000	
U004	第 3 針的縫製速度。(抓線) (可以以 100rpm 為單位設定)	400~3000	3000	
U005	第 4 針的縫製速度。(抓線) (可以以 100rpm 為單位設定)	400~3000	3000	
U006	第 5 針的縫製速度。(抓線) (可以以 100rpm 為單位設定)	400~3000	3000	
U007	第 1 針的線張力(抓線)	0~200	200	
U008	切線時的線張力	0~200	0	
U009	切線時的線張力變換同步時間	-6~4	0	
U010	第 1 針的縫製速度。(不抓線) (可以以 100rpm 為單位設定)	400~1500	400	
U011	第 2 針的縫製速度。(不抓線) (可以以 100rpm 為單位設定)	400~3000	900	
U012	第 3 針的縫製速度。(不抓線) (可以以 100rpm 為單位設定)	400~3000	3000	
U013	第 4 針的縫製速度。(不抓線) (可以以 100rpm 為單位設定)	400~3000	3000	
U014	第 5 針的縫製速度。(不抓線) (可以以 100rpm 為單位設定)	400~3000	3000	
U015	第 1 針的線張力(不抓線)	0~200	0	
U016	縫製開始的線張力(不抓線)變換 同步時間。	-5~2	0	
U025	壓腳分段開關	0：壓腳分段 1：禁止壓腳分段	1	

U026	2 級行程時壓腳分段高度調整	50~90	70	
U031	可以用操作鍵盤（清除鍵）停止縫紉機動作	0：無效 1：操作盤復位鍵 2：外接急停開關	0	
U032	可以禁止蜂鳴音響	0：不響蜂鳴音 1：操作盤操作音 2：操作盤操作音和報警提示音	2	
U033	設定抓線開放的針數	1~7 針	2	
U034	可以推遲抓線的同步時間	-20~0	0	
U035	可以禁止上線抓線控制	0：通常 1：禁止	1	
U036	選擇送布動作的同步時間 緊線不好時設定為 - 方向	-8~16	12	
U037	縫製結束後壓腳狀態選擇	0：先回起縫點再抬壓腳； 1：回起縫點同時抬壓腳； 2：踩踏板手動抬壓腳；	1	
U038	壓腳不上升時，只通過啟動開關可進行縫製	0：普通 1：禁止抬壓腳	0	
U039	縫製結束後是否檢索原點	0：不檢索原點 1：檢索原點	0	
U040	設定迴圈縫製時的原點檢索	0：不檢索原點 1：每 1 圖案結束	0	
U041	設定 P 花樣縫製時的原點檢索	0：不檢索原點 1：檢索原點	0	
U042	設定針杆停止位置	0：上位置 1：上死點	0	
U043	機頭 LED 照明燈亮度	0~10	5	值越大亮度越高 0 表示關閉
U046	可以禁止切線	0：通常 1：禁止切線	0	
U049	可以設定卷線速度	800~2000	1600	
U055	釘扣禁止起縫加固設置	0：起縫加固 1：起縫不加固	0	
U063	XY 縮放率設定方法	0：按百分比設定 1：按尺寸設定	0	
U135	起縫前壓腳動作順序	0：壓腳在起縫點待命 1：壓腳在原點待命	0	
U200	語言選擇	根據設置選擇語言	簡體中文	
U212	氣閥分離壓腳下降順序	0：同時下降 1：先下降左再下降右 2：先下降右再下降左	0	
U213	氣閥分離上升順序	0：同時上升 1：先上升左再上升右	0	

		2：先上升右再上升左		
U214	翻轉壓腳使能	0：禁止 1：使能	1	
U245	加油報警錯誤清除	按復位鍵清除	顯示機器累計運轉針數	

### 3 服務參數設置

服務參數有別於普通參數，一般禁止用戶自行更改，這些參數提供給專業技術人員，供其調試時使用。

#### 服務參數的開啟和變更

在準備鍵LED 指示燈熄滅的狀態下，長按模式鍵 **M** 持續按住3 秒，聽到蜂鳴器響聲後，就能對服務參數進行啟動與變更。

服務參數的修改與普通參數相同，具體操作方法可參考【2.7記憶體開關的啟動和變更】一節。

#### 服務參數清單

參數號	功能	調整範圍	初值	備註
K001	腳踏板類型	0：模擬單踏板 1：數字單踏板 2：雙踏板 3：雙踏板，但只運行踏板起 控制作用	0	
K002	中壓腳控制方式	0：無中壓腳控制 1：未使用 2：電磁鐵控制中壓腳 3：機械控制中壓腳	0	
K019	氣動外壓腳上升時間	0~90	30	
K021	標準踏板、踏腳開關位置	50~200	70	
K022	標準踏板、高低段行程開關位置	50~200	120	
K023	標準踏板、啟動開關位置	50~200	185	
K027	踩踏板時壓腳下降速度	100~4000pps	4000	
K028	踩踏板時壓腳上升速度	100~4000pps	1500	
K029	縫製結束時切線壓腳上升速度	100~4000pps	3000	
K043	切線時的機器旋轉數選擇	3~8	8	
K044	切線時在易於切線的方向選擇有 無送布的操作	0：無送布 1：有送布	0	
K045	切線時進行送布的針孔導向直徑 (可設定以0.2mm為單位)	16~40(1.6mm~4.0mm)	16	
K056	+X 方向(右側)的移動限定範圍	0~50mm	20	
K057	-X 方向(左側)的移動限定範圍	0~50mm	20	
K058	+Y 方向(後面)的移動限定範圍	0~30mm	15	
K059	-Y 方向(前面)的移動限定範圍	0~30mm	15	
K064	撥線方式選擇	0：電磁鐵撥線 1：電機撥線	1	
K066	壓腳聯動撥線操作脈衝數	30~60	45	
K074	壓腳控制模式切換	0：氣閥控制 1：電機控制	1	
K095	剪線角度	-10~10	0	
K097	暫停後的切線方式	0：自動切線 1：手動切線	1	

K102	X 步進電機全流參數	0~15	7	需重新上電生效
K104	Y 步進電機全流參數	0~15	11	需重新上電生效
K106	抓線步進電機全流參數	0~15	2	需重新上電生效
K108	壓腳步進電機全流參數	0~15	14	需重新上電生效
K109	X 步進電機半流參數	0~15	7	需重新上電生效
K110	Y 步進電機半流參數	0~15	6	需重新上電生效
K111	壓腳步進電機半流參數	0~15	5	需重新上電生效
K112	主軸停車補償	-10~10	0	
K120	加潤滑油報警針數	3000~12000	5000	單位：萬針
K121	計數器鎖定	0：可清零可加減； 1：可清零不可加減； 2：不可清零可加減； 3：不可清零不可加減	0	
K122	OC 長度微調	-128~128	0	
K123	OD 長度微調	-128~128	0	
K124	BD 長度微調	-512~512	0	
K125	OC 長度	1780~2380	2080	
K126	OD 長度	1440~2040	1740	
K127	BD 長度	430~630	530	
K128	步進驅動類型設定	0：DSP1 閉環，DSP2 閉環； 1：DSP1 開環，DSP2 閉環； 2：DSP1 閉環，DSP2 開環； 3：DSP1 開環，DSP2 開環；	0	需重新上電生效
K135	分線延時	-10~30	0	
K137	起針夾線器鬆開角度	-150~150	0	
K138	起針夾線器剪線後夾緊時間	-2~1	0	-2 表示關閉起針夾線器剪線後夾緊動作
K140	線張力控制方式	0：電子夾線 1：機械夾線	0	
K141	支線張力電磁鐵吸合力度微調	-20~20	0	
K142	支線張力電磁鐵保持力度微調	-40~40	0	
K150	機頭翻起安全開關可以無效	0：普通 1：機頭翻起安全形狀無效	0	

K160	禁止反踩踏板急停	0~1	0	0：允許反踩急停 1：禁止反踩急停
K172	斷線檢測針數設置	0~10	0	大於 0 表示斷線後過多少針急停 0 表示關閉斷線檢測
K174	剪刀位置感測器使能	0：禁用 1：開啟	1	
K227	主軸電機類型	0：0830-F11 1：0830-F01	0	需重新上電生效
K241	功能選擇	0：套結（加固） 5：花樣套結 7：釘扣	0	





注：以上參數只供維修人員使用，用戶不能輕易改動。

### 恢復出廠默認設置







當用戶無意中修改了某些出廠時設置好的參數或者電控系統出現故障時，可以嘗試使用“恢復出廠默認設置”功能，進行系統恢復。

注意：恢復出廠預設設置，使用者以前設定的資料參數將會被覆蓋，使用此功能時，請慎重考慮，如不清楚，應及時聯繫廠家技術人員，在其指導下進行操作。

具體操作步驟如下：

1. 在縫製燈熄滅的狀態下，按住模式鍵  持續3秒，面板蜂鳴器會鳴響一聲，然後按  鍵選中“13 恢復出廠設置”，然後按編輯鍵 ，進入恢復出廠設置功能表，再按專案選擇鍵  選擇要恢復的項目，確定後按準備鍵 ，確認執行恢復操作。面板會先提示“操作執行中，請勿關機！”  
表示正在執行恢復操作，此時不可以關閉電源。當經過一段時間後恢復完成，面板會提示“請關機！”資訊，關閉電源再打開電源後，就完成了恢復出廠設置的操作。
2. 注意：在確認恢復操作後，系統進行恢復過程中，面板會提示“操作執行中，請勿關機！”，如果斷電，恢復過程將被迫中斷，將不能完成恢復出廠默認設置，會導致操作失敗。





### 軟體版本顯示

在縫製燈  滅的狀態下，長按  鍵3秒，此時能聽到蜂鳴器響一聲，鬆開  鍵，然後按  鍵選中“08查詢軟體版本”。再按  鍵進入軟體版本查看介面。之後按  或  鍵選擇需要查看的版本。軟體版本按順序顯示如下：

主控：機型-MC-廠家代號-版本號  
 操作箱：機型-LKD2-廠家代號-版本號  
 步進 1：機型-MD1-廠家代號-版本號  
 步進 2：機型-MD2-廠家代號-版本號

### 查看運行總針數和清除加潤滑油報警資訊



當機器運行一段時間後，可能會出現“M-333 機器需要加潤滑油了”提示資訊，表示需要補充潤滑油。

在此種情況下，可以先按復位鍵清除報警資訊，然後按模式鍵進入系統功能表，選擇“01系統U參數”，按編輯按鍵進入U參數設置模式，再按專案選擇鍵選擇“U245清除加潤滑油總針數”，按復位鍵就可以清除，機器運行總針數，不再顯示該提示資訊了。

### 使用者密碼設置及系統 U/K 參數鎖定

系統提供了可供使用者自行設置的密碼管理機制，使用者輸入設定密碼後，可以解鎖一些高級功能，如設置系統參數加鎖保護，避免因為誤操作修改了關鍵參數而導致機器出現異常的情況。



#### 修改使用者密碼





如果需要使用使用者密碼，需要先進入密碼管理模式修改密碼，操作方法為：在縫製燈熄滅的狀態下，長按模式鍵持續按住3秒，聽到蜂鳴器響聲後，按項目選擇鍵選擇“14密碼設置”，然後按編輯按鍵進入密碼輸入介面。

<p>通過按項目選擇鍵可以向後移動、向前刪除輸入的密碼位元，按變更資料鍵設置當前選中位的密碼字元。允許輸入的密碼字元範圍是“0~9”，“A~Z”。當輸入完畢後，按編輯按鍵確認，如果密碼輸入正確，就會進入新密碼輸入介面，否則提示錯誤並返回系統功能表。</p> <p><b>注意：</b>出廠預設的密碼是都是固定的，有關這方面的詳細資訊請您與您的機械供應商或代理商聯繫。</p>	
<p>需要輸入第一行“新密碼”和第二行“確認輸入”的密碼完全一致時，最後按編輯按鍵確認才會修改成功，否則將提示“輸入不一致”的錯誤信息。如果想要放棄修改密碼操作而中途退出時，可以按返回鍵或模式鍵退出。</p> <p><b>注意：</b>在成功修改密碼後，請務必牢記密碼並避免密碼資訊洩露！</p>	

#### 設置系統 U/K 參數鎖

此功能可以讓使用者自行對需要保護的參數加鎖或解鎖，每一個系統 U 參數和 K 參數都可以獨立設置鎖定或解鎖狀態。這裡以系統 U 參數鎖舉例說明操作方法，K 參數方法與 U 參數類似。

在系統功能表中按專案選擇鍵選擇“15系統U參數鎖”，然後按編輯按鍵進入密碼輸入介面，輸入正確密碼並按編輯按鍵確認後即可進入系統U參數鎖設置介面。如果密碼輸入不正確，是不能進入該介面的。



在該介面下，用專案選擇鍵  選擇選擇要修改鎖定/解鎖狀態的系統 U 參數，用變更資料鍵  修改參數鎖定/解鎖狀態值。如果顯示為  表示對參數加鎖，如果顯示為  表示對參數解鎖。被加鎖的參數，在對應的參數修改介面中會顯示鎖定圖示，嘗試修改參數值時會進入輸入密碼的介面，只有輸入了正確的密碼後才可以暫時解開該參數的鎖定狀態，可以修改參數值。一旦從參數設置模式介面返回後，再次進入參數設置介面，這些被設置為鎖定的參數仍然會恢復鎖定狀態。





當設置完畢參數鎖以後，可以按返回鍵  或模式鍵  保存並退出。

## 4 釘扣功能

### 釘扣功能設定

<p>1、在縫製燈  滅的狀態下，長按  鍵3秒，此時能聽到蜂鳴器響一聲，鬆開  鍵，即開啟了服務參數變更；</p> <p>2、按  鍵，選擇“12系統K參數”，按  進入，再按  鍵，選擇K241 號參數；</p>	 <p>The image shows a control panel with a digital display. The display shows 'K241' and '7'. Below the display, there are several buttons: 'F1' through 'F5', a power button, a blue button with a pencil icon, an 'M' button, and a button with a printer icon. To the right of the display are four directional buttons: up, down, left, and right, along with a '+' and '-' button.</p>
--	---

3、按  鍵，將參數值變更為“7”，然後按  鍵確認修改。此時面板會先提示“操作執行中，請勿關機！”的資訊，一定不要關閉電源。經過一段時間後面板提示“請關機！”的資訊，就可以關閉電源了；

4、斷電並再次上電後，機器功能變更為釘扣功能。

**注意：**機器的釘扣功能需要釘扣所需的專用壓腳等輔助外設，有關這方面的詳細資訊請您與您的機械供應商或代理商聯繫。

## 5 通過U盤升級花樣

可支援 VDT花樣的單個導入(追加)：



- (01)導入花樣：導入(追加)花樣，如果導入的花樣號已經存在則進行覆蓋；
- (02)匯出花樣：匯出所有外置花樣到 USB 存放裝置；
- (03)刪除花樣：清除(格式化)面板外置花樣存儲區域；

### 花樣升級操作

電控可以使用 U 盤將 VDT 格式的花樣輸入到系統中，升級後的花樣編號為 101~200。也可以將電控中 101~200 號已經存在的花樣匯出到 U 盤中。

- 1) 使用花樣編輯軟體製作 VDT 格式的花樣檔，並命名為“XXX.VDT”(注：XXX必需為 101~200的花樣號碼，同時該號碼也是升級後的花樣號)。
- 2) 在 U盤根目錄下建立一個名為 DH\_PAT的資料夾，將步驟 1中製作好的花樣保存到 U盤中的這個 DH\_PAT目錄下，一次可以導入多個花樣檔。



- 3) 在準備鍵LED指示燈熄滅的狀態下，按模式鍵 **M** 進入系統功能表，按專案選擇鍵  選中“10花樣導入匯出”，再按編輯按鍵  進入該模式。

- 4) 按項目選擇鍵  選中“01導入花樣”，並將存入花樣的U盤插入到面板右側的USB介面上。

- 5) 按準備鍵 ，面板顯示“操作執行中，請勿關機！”，開始執行花樣導入操作。

注意：在此步驟操作之前，請確認已經先將 U盤插入面板 USB介面，如若未插入 U盤而執行該步驟操作，則無法進行升級操作，面板會提示“M-324U 盤未連接”錯誤。



- 6) 當升級完畢後，面板顯示“操作成功！”並自動回到導入花樣模式介面，表示花樣升級完成。

注意：如果電控中已經存在 101~200號升級的某些花樣，也可以通過在 U盤中存入命名編號與電控中已存在花樣不同的花樣檔，並按照上述操作進行花樣追加；如果 U盤中存入命名編號與電控中已存在花樣相同的花樣檔，則進行升級操作後，電控中那些編號相同的花樣將被替換。

另外，在第 4步中，除了將功能號改為 01進行花樣升級導入操作外，還可以將功能號改為 02 和03，分別進行花樣的匯出和刪除操作。改為 02時的功能是將面板中已導入的花樣備份操作，而改為 03時的功能是將所有 101~200號花樣全部刪除清空，當電控出現報“M-318外置花樣存儲空間已滿”或“M-319外置花樣存儲區資料格式異常”錯誤時，可以嘗試此刪除操作。

7) 打開花樣鎖：花樣升級完畢後，在縫製介面如果選擇花樣號時，如果不能選中新升級的 U 盤花樣，可能是因為沒有將花樣鎖打開，101~200 號花樣出廠默認時是鎖定不能選擇的，需要進行如下操作：

在準備鍵 LED 指示燈熄滅的狀態下，按模式鍵進





 入系統功能表，按專案選擇鍵  選中“03 普通花樣鎖”，再按編輯按鍵  進入該模式。

在該模式中，左半部分 A 顯示的是普通花樣號，

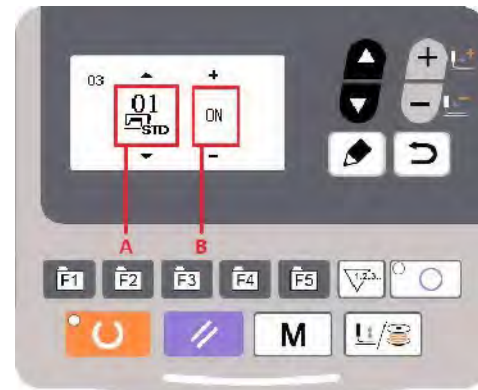
可以按項目選擇鍵  在 1~200 之間切換；右半部份 B 顯示的是花樣狀態，顯示為“ON”時花樣打開可以縫紉，顯示為“OFF”時花樣鎖定不能縫紉。

可以用資料變更鍵  修改花樣打開或鎖定的狀態。











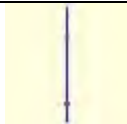
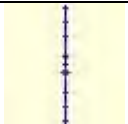

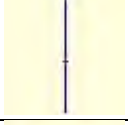



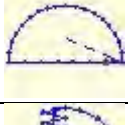
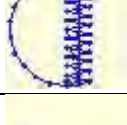
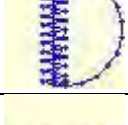

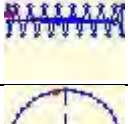
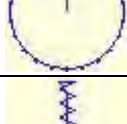
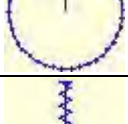
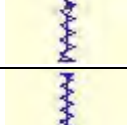
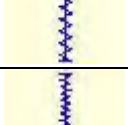

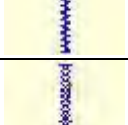
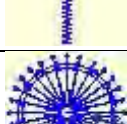
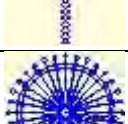

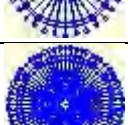

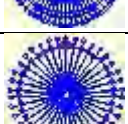

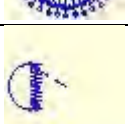

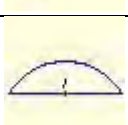
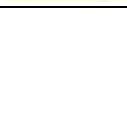
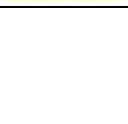



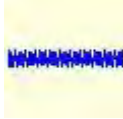



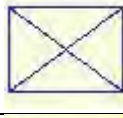

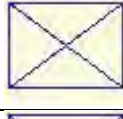
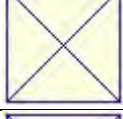
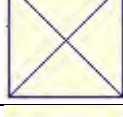
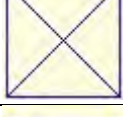
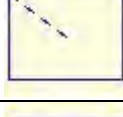
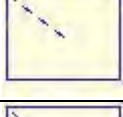
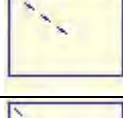
8) 用項目選擇鍵  和用數據變更鍵  將導入的花樣打開，按返回鍵  保存修改回到系統功能表，再按返回鍵  返回到正常縫製模式。



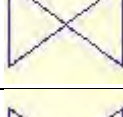
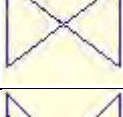
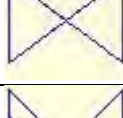

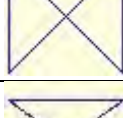
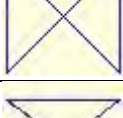

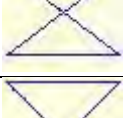
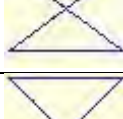
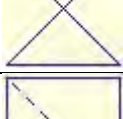
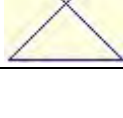
## 6 附錄 1

1900A套結機花樣一覽表

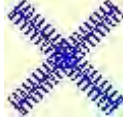

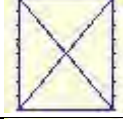
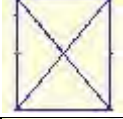
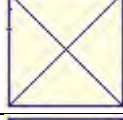
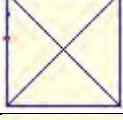
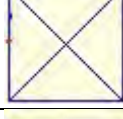
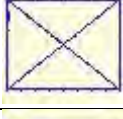



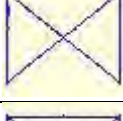
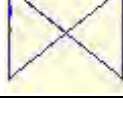
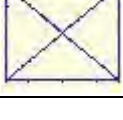

























NO	縫紉圖案	針數	長×寬 (mm)	NO	縫紉圖案	針數	長×寬 (mm)
1		41	16×2	2		41	10.1×2
3		41	16×2.4	4		41	24×3
5		27	10×2	6		27	16×2.4
7		35	10×2	8		35	16×2.4
9		55	24×3	10		63	24×3
11		20	6×2.4	12		27	6.1×2.4
13		35	6×2.4	14		14	8×2
15		20	8×2.2	16		27	8×2
17		20	10×0	18		27	10×0
19		27	25.2×0	20		35	24.8×0
21		40	25.2×0	22		43	35×0
23		27	4×20	24		35	4×20
25		41	4×20	26		55	4×20

27		17	0x20	28		20	0x10
29		20	0x20	30		27	0x20
31		51	10.1x7	32		62	12.1x7
33		23	10.2x6	34		30	12x6
35		47	7x10	36		47	7x10
37		89	24x3	38		27	8x2
39		25	11.8x12	40		45	12x12
41		28	2.4x20	42		38	2.4x25
43		38	2.4x25	44		57	2.4x30
45		75	2.4x30	46		41	2.4x30
47		89	8x8	48		98	8x8
49		147	8x8	50		163	8x8
51		110	7.9x7.9	52		120	7.9x7.9
53		130	7.9x7.9	54		51	12.4x10.2
55		50	12.4x10.2	56		52	21x6

57		57	21×6	58		99	19×3
59		115	40×5	60		115	40×5
61		308	6×25	62		257	6×20
63		108	40×30	64		80	40×30
65		64	40×30	66		96	30×30
67		76	30×30	68		60	30×30
69		52	40×30	70		40	40×30
71		32	40×30	72		44	30×30
73		36	30×30	74		28	30×30
75		60	40×30	76		48	40×30
77		36	40×30	78		56	30×30
79		44	30×30	80		36	30×30
81		67	40×30	82		51	40×30
83		39	40×30	84		55	30×30
85		35	30×30	86		42	30×30















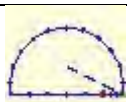
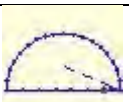

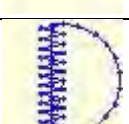

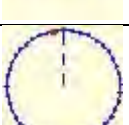
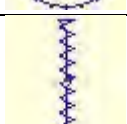
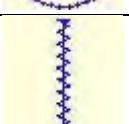
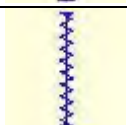
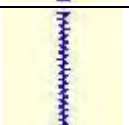
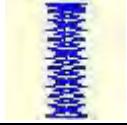

87		145	16.2×16.2	88		153	12×12.4
89		74	20×24	90		54	20×24
91		65	20×20	92		49	20×20
93		39	20×20	94		63	25×20
95		51	25×20	96		45	25×20
97		42	25×20	98		33	25×20
99		27	25×20	100		88	30×25

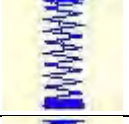

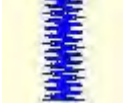



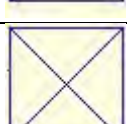
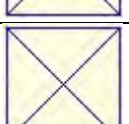













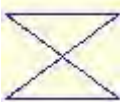

釘扣機花樣一覽表



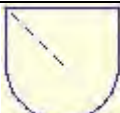

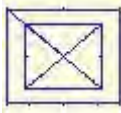
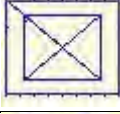
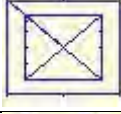
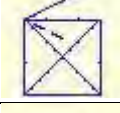

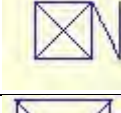
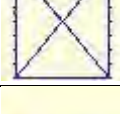
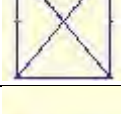



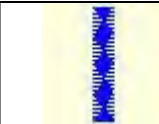

NO	縫紉圖案	縫線 (根)	標準縫 製長度 X(mm)	標準縫 製長度 Y(mm)	NO	縫紉圖案	縫線 (根)	標準縫 製長度 X(mm)	標準縫 製長度 Y(mm)
1 34		6-6	3.4	3.4	18 44		6	3.4	0
2 35		8-8			19 45		8		
3		10-10			20		10		
4		12-12			21		12		
5 36		6-6			22		16		
6 37		8-8			23 46		6	0	3.4
7		10-10			24		10		
8		12-12			25		12		
9 38		6-6			26 47		6-6		
10 39		8-8			27		10-10		
11		10-10			28 48		6-6		
12 40		6-6			29		10-10		
13 41		8-8			30 49		5-5-5	3.0	2.5
14		10-10			31		8-8-8		
15 42		6-6			32 50		5-5-5		
16 43		8-8			33		8-8-8		
17		10-10							

1906A套結花樣一覽表

NO.	縫紉圖案	針數	長×寬 (mm)	NO.	縫紉圖案	針數	長×寬 (mm)
1		41	16.1×2	2		41	10.2×2
3		41	16×2.4	4		41	24×3
5		27	10.1×2	6		27	16×2.4
7		35	10.1×2	8		35	16×2.4
9		55	24×3	10		63	24×3
11		20	6.1×2.4	12		27	6.2×2.4
13		35	6.1×2.4	14		14	8×2
15		20	8×2	16		27	8×2
17		20	10×0	18		27	10×0
19		27	25.2×0	20		35	24.8×0
21		40	25.2×0	22		43	35×0
23		27	4×20	24		35	4×20
25		41	4×20	26		55	4×20
27		17	0×20	28		20	0×10

29		20	0x20	30		27	0x20
31		51	10.1x7	32		62	12.1x7
33		23	10.2x6	34		30	12x6
35		47	7x10	36		47	7x10
37		89	24x3	38		27	8x2
39		25	11.8x12	40		45	12x12
41		28	2.4x20	42		38	2.4x25
43		38	2.4x25	44		57	2.4x30
45		141	10x30	46		122	10x30
47		97	10x30	48		109	10.1x30
49		122	10.1x30	50		265	10x30
51		108	40x30	52		80	40x30
53		64	40x30	54		96	30x30
55		76	30x30	56		60	30x30
57		52	40x30	58		40	40x30

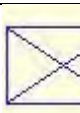
59		32	40x30	60		44	30x30
61		36	30x30	62		28	30x30
63		60	40x30	64		48	40x30
65		36	40x30	66		56	30x30
67		44	30x30	68		36	30x30
69		67	40x30	70		51	40x30
71		39	40x30	72		55	30x30
73		43	30x30	74		35	30x30
75		42	30x30	76		32	30.1x30
77		26	30x30	78		103	30x25
79		82	30x25	80		64	30x25
81		80	20x30	82		60	20x30
83		80	30x20	84		60	30x20
85		74	20x24	86		54	20x24
87		115	40x5	88		115	40x5

89		93	5×30	90		109	5×30
91		65	20×20	92		49	20×20
93		39	20×20	94		63	25×20
95		51	25×20	96		45	25×20
97		42	25×20	98		33	25×20
99		111	60×40	100		91	60×40

### 主控異常資訊一覽表

錯誤代碼	異常名稱	異常內容	原因及解除方法
E-001	腳踏板未在中央位置	在進入準備縫製狀態過程中腳踏板被踩下。	確認進入準備縫製介面時踏板沒有被踩下。
E-002	暫停	縫紉機運轉中按了復位元開關，暫停。	按重定開關切線後，再次開始或返回原點。
E-003	機頭翻倒異常	機頭翻倒檢測開關被設定為 ON。	在放倒機頭的狀態不能運轉。請返回到正常的位置。技術人員可直接用短路塊將機頭板上的 2P 藍色插頭短路。
E-004	電壓過低異常	電源電壓不足。	採樣 UZKIN 類比量過低，確認電源電壓及相關電路。
E-005	電壓過高異常	電源電壓超過規定值。	檢測到 AC_OVDT 信號為高，確認電源電壓及相關電路。
E-007	主軸驅動器不良	主軸驅動器檢測出異常。	關閉電源，稍待一些時間後再次打開電源。
E-008	24V 電源異常	24V 過流。	關閉電源，稍待一些時間後再次打開電源。
E-009	24V 電源異常	24V 電壓過低。	關閉電源，稍待一些時間後再次打開電源。
E-010	氣閥（風扇）故障	開機後系統檢測到氣閥或風扇電壓信號異常。	關機，檢查外設有無短路情況。
E-012	壓腳位置異常	壓腳不在正確位置。	關閉電源開關，確認機頭信號電路板上的 CZ025 是否鬆動脫落。若未鬆動，檢查該路光藕。
E-013	編碼器未接	不能檢測 ADTC 信號。	關閉電源開關，確認 X5 插頭是否插緊。

錯誤代碼	異常名稱	異常內容	原因及解除方法
E-014	電機運行異常	主軸電機在運行過程中到達 0° 時電氣角度範圍異常。	關機。查看電機編碼器信號是否正常。
E-015	超過縫製區域	超過縫製區域。	按重定開關，確認圖案和 X、Y 放大率。 觸發條件：軟體花樣計算報錯。
E-016	針杆上位置異常	針杆不在上位置。	主軸停車位置錯誤，可能是主軸驅動的原因，也可能是人為轉動所致。轉動手輪，把針杆返回到上位置。
E-018	切線切刀位置異常	切線刀不在正確位置。	關閉電源開關，確認機頭信號電路板上的 CZ024 是否鬆動脫落。若未鬆動，檢查該路光藕。
E-019	急停開關未在正常位置	啟動之前檢測到急停開關被按下。	自恢復錯誤。
E-020	步進軟體版本錯誤	步進板軟體版本錯誤。	更換套結機使用的步進板或更新步進辦程式。
E-022	機器老化停止	在老化模式下機器進入了停止狀態。	關機。
E-023	抓線位置異常	抓線裝置不在正確位置。	關閉電源開關，確認機頭信號電路板上的 CZ026 是否鬆動脫落。 若未鬆動，檢查該路光藕。
E-025	X 原點檢索異常	X 原點感測器不變化。	關閉電源開關，確認機頭信號電路板 CZ021、控制箱 X9 是否鬆動、脫落。
E-026	Y 原點檢索異常	Y 原點感測器不變化。	關閉電源開關，確認機頭信號電路板 CZ022、控制箱 X9 是否鬆動、脫落。
E-027	壓腳原點檢索異常	壓腳原點感測器不變化。	關閉電源開關，確認機頭信號電路板 CZ025、控制箱 X9 是否鬆動、脫落。
E-028	抓線原點檢索異常	抓線原點感測器不變化。	關閉電源開關，確認機頭信號電路板 CZ026、控制箱 X9 是否鬆動、脫落。
E-030	主電路板-步進電路板通信異常	主電路板與步進電路板不能通信或通訊錯誤。	關閉電源，稍待一些時間後再次打開電源。檢查通訊線纜及主機板與驅動板是否有故障。
E-031	步進驅動異常	步進驅動板過流。	關閉電源，稍待一些時間後再次打開電源。
E-034	主軸驅動器不良	主軸驅動器檢測出異常。	關閉電源，稍待一些時間後再次打開電源。

錯誤代碼	異常名稱	異常內容	原因及解除方法
E-035	主機板 IPM 暫態過流	主機板 IPM 驅動模組短時間內電流過大。	關閉電源，稍待一些時間後再次打開電源。更換主軸電機確認電機是否損壞；如果問題不能解決，請更換主機板。
E-036	主機板 IPM 多次過流	主機板 IPM 驅動模組在上電後累計多次出現過流。	關閉電源，稍待一些時間後再次打開電源。更換主軸電機確認電機是否損壞；如果問題不能解決，請更換主機板。
E-037	主軸過流	馬達停轉。	在機械不卡的情況下，檢查主軸編碼器是否連接良好。
E-038	機器鎖定	因為發生了某些故障，縫紉機主軸不能轉動。	發送主軸運轉命令後，主軸電機無反映。查看主軸電機驅動電路六路 PWM 波形是否正常，編碼器回饋信號是否正常，也可能是機械卡死所造成。
E-039	主軸超速	在機器運轉過程中檢測到主軸電機實際轉速超過限定最大值。	關閉電源，稍待一些時間後再次打開電源。
E-040	停車電流異常	主軸停車過程中出現過流。	關閉電源，稍待一些時間後再次打開電源。更換主軸電機確認電機是否損壞；如果問題不能解決，請更換主機板。
E-043	剪線電機原點檢索異常	剪線原點感測器不變化。	關閉電源開關，確認機頭信號電路板 CZ026、控制箱 X9 是否鬆動、脫落。
E-044	下位機機頭板參數異常	下位機從機頭板讀取參數異常。	確認機頭板是否完好，X9 線纜是否插好。可以通過按復位鍵使用 67 號參數嘗試對機頭板參數進行恢復操作。
E-056	步進閉環 DSP1(X25/X27) 通信錯誤	步進對接收到的指令進行校驗未通過。	查看 SPI 通信線纜連接是否正確、牢固。
E-057	步進閉環 DSP1 第一路(X27)過流	硬體檢測到有大電流出現。	首先檢查電機是否正常，可測量電阻、電感值是否在正常範圍內。如果電機正常，則需確認步進板硬體是否正常。
E-058	步進閉環 DSP1 第一路(X27)超差	檢測到的編碼器回饋位置與程式中的指令位置不符。	將步進電機改成開環模式運行，如果可以正常動作，則電機正常。如果電機不能正常動作，則需要排查步進板驅動部分及電機本體。做完上述工作後，排查編碼器部分，看編碼器線纜是否插錯，是否插牢，是否有編碼器信號線損壞以及步進板信號回饋部分及編碼器本體是否正常。
E-059	步進閉環 DSP1 第一路(X27)超速	通過編碼器回饋信號檢測到電機轉速異常時報此錯誤。	檢查方法同檢查超差錯誤。

錯誤代碼	異常名稱	異常內容	原因及解除方法
E-060	步進閉環 DSP1 第二路(X25)過流	硬體檢測到有大電流出現。	首先檢查電機是否正常，可測量電阻、電感值是否在正常範圍內。如果電機正常，則需確認步進板硬體是否正常。
E-061	步進閉環 DSP1 第二路(X25)超差	檢測到的編碼器回饋位置與程式中的指令位置不符。	將步進電機改成開環模式運行，如果可以正常動作，則電機正常。如果電機不能正常動作，則需要排查步進板驅動部分及電機本體。做完上述工作後，排查編碼器部分，看編碼器線纜是否插錯，是否插牢，是否有編碼器信號線損壞以及步進板信號回饋部分及編碼器本體是否正常。
E-062	步進閉環 DSP1 第二路(X25)超速	通過編碼器回饋信號檢測到電機轉速異常時報此錯誤。	檢查方法同檢查超差錯誤。
E-063	步進閉環 DSP2(X21/X23) 通信錯誤	步進對接收到的指令進行校驗未通過。	查看 SPI 通信線纜連接是否正確、牢固。
E-064	步進閉環 DSP2 第一路(X23)過流	硬體檢測到有大電流出現。	首先檢查電機是否正常，可測量電阻、電感值是否在正常範圍內。如果電機正常，則需確認步進板硬體是否正常。
E-065	步進閉環 DSP2 第一路(X23)超差	檢測到的編碼器回饋位置與程式中的指令位置不符。	將步進電機改成開環模式運行，如果可以正常動作，則電機正常。如果電機不能正常動作，則需要排查步進板驅動部分及電機本體。做完上述工作後，排查編碼器部分，看編碼器線纜是否插錯，是否插牢，是否有編碼器信號線損壞以及步進板信號回饋部分及編碼器本體是否正常。
E-066	步進閉環 DSP2 第一路(X23)超速	通過編碼器回饋信號檢測到電機轉速異常時報此錯誤。	檢查方法同檢查超差錯誤。
E-067	步進閉環 DSP2 第二路(X21)過流	硬體檢測到有大電流出現。	首先檢查電機是否正常，可測量電阻、電感值是否在正常範圍內。如果電機正常，則需確認步進板硬體是否正常。
E-068	步進閉環 DSP2 第二路(X21)超差	檢測到的編碼器回饋位置與程式中的指令位置不符。	將步進電機改成開環模式運行，如果可以正常動作，則電機正常。如果電機不能正常動作，則需要排查步進板驅動部分及電機本體。做完上述工作後，排查編碼器部分，看編碼器線纜是否插錯，是否插牢，是否有編碼器信號線損壞以及步進板信號回饋部分及編碼器本體是否正常。

錯誤代碼	異常名稱	異常內容	原因及解除方法
E-069	步進閉環 DSP2 第二路(X21)超速	通過編碼器回饋信號檢測到電機轉速異常時報此錯誤。	檢查方法同檢查超差錯誤。
E-070	步進板 90V 電源過流	步進板 90V 電源過流。	關閉電源，稍待一些時間後再次打開電源。

面板異常資訊一覽表

錯誤代碼	異常名稱	異常內容	原因及解除方法
M-300	存儲異常	面板定義的資料存在錯誤	內部錯誤，需要升級面板程式
M-301	記憶體異常	面板記憶體資料異常	內部錯誤，需要升級面板程式
M-302	機型異常	面板上電讀取機型參數值不在已定義的機型範圍以內。	按復位鍵後進入 K241 號參數，選擇已定義的機型後保存參數。
M-303	系統 UK 參數異常	面板讀取 EEPROM 中記憶體參數範圍異常	按重定鍵後進入系統功能表，進行恢復出廠設置操作。
M-304	機頭板參數異常	面板接收到下位機發送的機頭板參數範圍異常。	按重定鍵後進入系統功能表，進行恢復出廠設置操作。
M-305	普通花樣參數異常	面板使用花樣參數時發現花樣參數範圍異常。	按重定鍵後進入系統功能表，進行恢復出廠設置操作。
M-306	花樣不存在或未開啟	被準備的圖案 NO.沒有登記到 ROM 裡，或是被設定為不能讀出。圖案 NO.為 0。	按重定開關，確認圖案 NO.。確認使用花樣已經在普通花樣鎖打開。
M-307	花樣數據異常	面板讀取花樣縫紉資料時發現標誌資料格式異常。	選擇其他號碼的花樣。
M-308	縫紉數據過大	計算花樣資料時發現花樣資料過大超出正常範圍。	更換其他花樣縫紉。
M-309	花樣超出縫製範圍	計算花樣資料時發現花樣超出縫製區域。	按重定開關，確認圖案輪廓尺寸是否在 K056、K057、K058 和 K059 參數限定範圍以內。
M-310	針距超出正常範圍	計算花樣資料時發現花樣針距超出正常範圍。	按重定開關，確認圖案和 X、Y 放大率。
M-311	花樣資料傳輸異常	面板給主控制器發送花樣資料過程中出現錯誤。	檢查花樣是否正確，檢查面板與主控制器通信線纜是否連接正常。
M-312	普通花樣鎖載入異常	面板載入 EEPROM 中普通花樣鎖資料時出現錯誤。	按重定鍵後進入系統功能表，進行恢復出廠設置操作。
M-313	當前花樣參數異常	面板載入 EEPROM 中當前花樣參數資料時出現錯誤。	按重定鍵後進入系統功能表，進行恢復出廠設置操作。
M-314	參數設定超出正常範圍	設置參數值超出正常範圍。	按復位鍵後重新修改設置參數值。
M-315	縫紉計數器載入異常	面板載入 EEPROM 中縫紉計數器資料時出現錯誤。	按重定鍵後進入系統功能表，進行恢復出廠設置操作。

錯誤代碼	異常名稱	異常內容	原因及解除方法
M-316	縫紉計數器用盡	縫紉完成後計數器到達設置的限定值。	按復位鍵解除。
M-317	面板與主控通信異常	主電路板與操作面板不能通信或通訊錯誤。	關閉電源，稍待一些時間後再次打開電源。檢查通訊線纜及主機板與操作面板是否有故障。
M-318	外置花樣存儲空間已滿	在導入 USB 花樣時檢測到面板存儲外置花樣數據的記憶體空間已滿。	先將現有內置花樣匯出後，刪除花樣後再進行花樣導入操作。
M-319	外置花樣存儲區資料格式異常	操作頭讀取外置花樣數據格式資訊時發現標誌資料異常。	進入系統功能表的花樣導入匯出模式，執行刪除花樣操作。
M-320	導入花樣已存在	在導入 USB 花樣時檢測到面板中已經有相同號碼的外置花樣。	將 USB 存放裝置中要導入的花樣名更改為未使用的號碼再進行導入操作。
M-321	導入花樣未找到	在導入 USB 花樣時在 USB 存放裝置上沒有找到要導入花樣號的花樣文件。	選擇在 USB 存放裝置上已存在花樣號的花樣檔進行導入。
M-322	花樣刪除錯誤	在刪除面板外置花樣時檢測到要刪除花樣號的花樣資料不存在。	選擇已經存在花樣號的花樣資料進行刪除。
M-323	花樣讀取錯誤	面板在從外置花樣資料存儲區域讀取花樣資料時出現異常。	選擇其他號碼的花樣。
M-324	U 盤未連接	在進行花樣導入、匯出操作時面板檢測到讀寫 USB 存放裝置異常。	更換 USB 存放裝置進行操作。
M-325	導入花樣文件尺寸過大	在進行花樣導入操作時，面板檢測到導入的花樣超出了最大尺寸限制。	確認要導入的花樣檔尺寸都在合理範圍以內。
M-326	外置花樣不存在	縫紉準備時讀取外置花樣不存在。	選擇其他號碼的花樣。
M-327	要刪除的 P 花樣被 C 花樣引用	在刪除 P 花樣時發現該 P 花樣已經被加入到 C 花樣中。	先將該 P 花樣從 C 花樣中刪除，再執行刪除 P 花樣的操作。
M-328	U 盤中沒有花樣	在進行花樣導入操作時，面板檢測到 USB 存放裝置中沒有花樣。	確定已經將花樣檔命名正確並保存在 USB 存放裝置指定目錄中。

M-329	沒有登記 P 花樣	在進入 P 花樣複製/刪除或 C 花樣複製/刪除模式前發現沒有登記任何 P 花樣。	請先登記 P 花樣再進入這些模式。
<b>錯誤代碼</b>	<b>異常名稱</b>	<b>異常內容</b>	<b>原因及解除方法</b>
M-330	普通花樣全部被關閉	在進入 P 花樣登記模式前發現所有普通花樣都已經被關閉。	請先進入普通花樣鎖模式解鎖普通花樣在執行操作。
M-331	P 花樣已滿不能登記 P 花樣	在進入 P 花樣登記模式前發現所有 P 花樣都已經被登記。	請先刪除一部分 P 花樣後再登記新的 P 花樣。
M-332	不能刪除最後的 C 花樣	在刪除 C 花樣時發現當前刪除的是最後一個 C 花樣。	不允許刪除最後一個僅剩的 C 花樣。
M-333	機器需要加潤滑油了	機器運轉到了向指定位置補充潤滑油的時期，所以縫紉機停止了。	按復位鍵後，進入參數 U245，按復位鍵清零後，可以繼續使用。
M-999	未知錯誤	面板未定義的錯誤。	關機，更新操作頭程式。

## 7 附錄 2

### 操作箱安裝尺寸



# 電控箱安裝尺寸

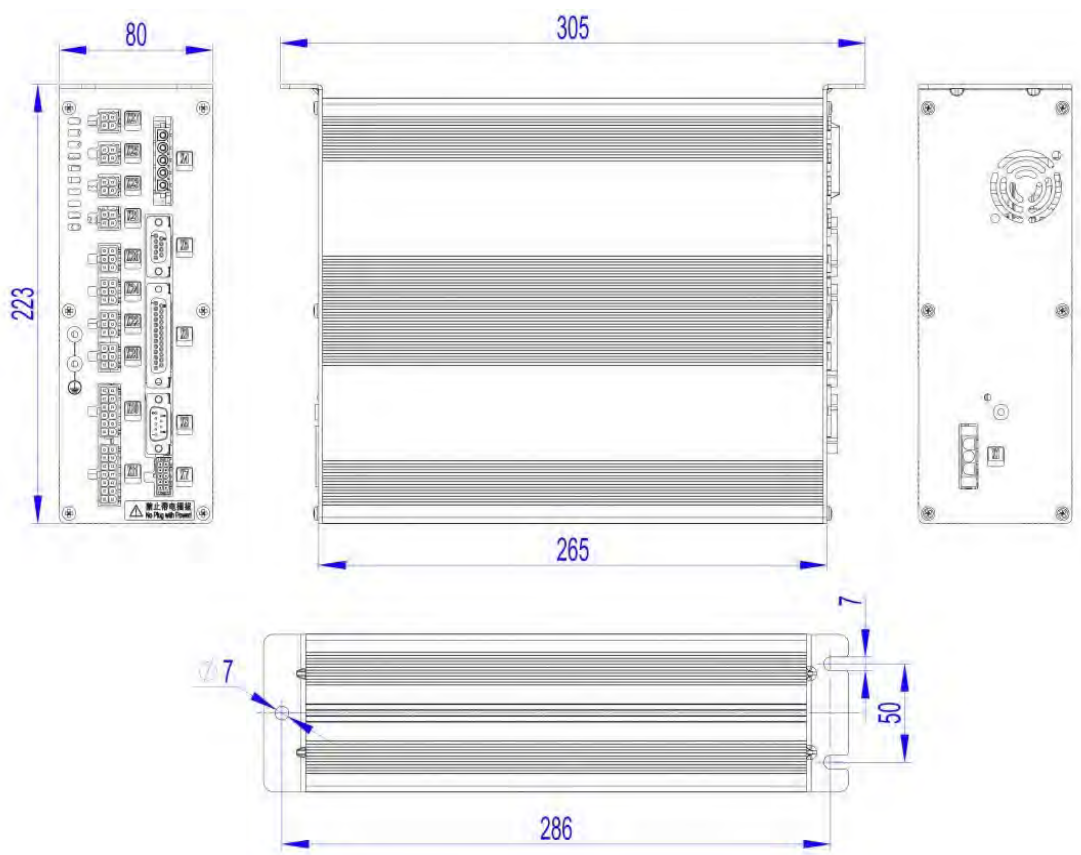

### 7.3 系統框圖

#### (1) MSC201-2K/A 系統框圖

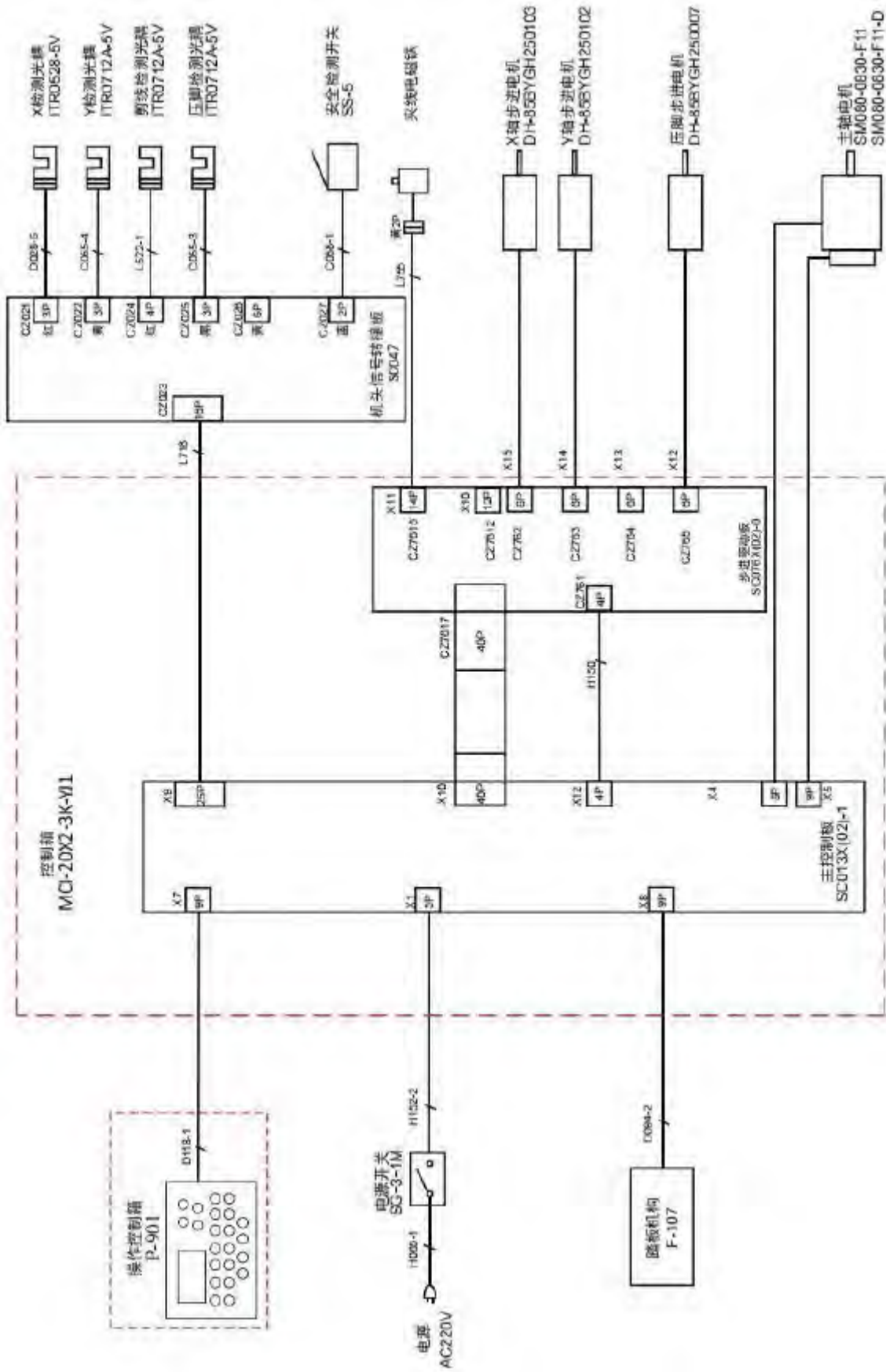



(3)TASC201-2K-A系統框圖

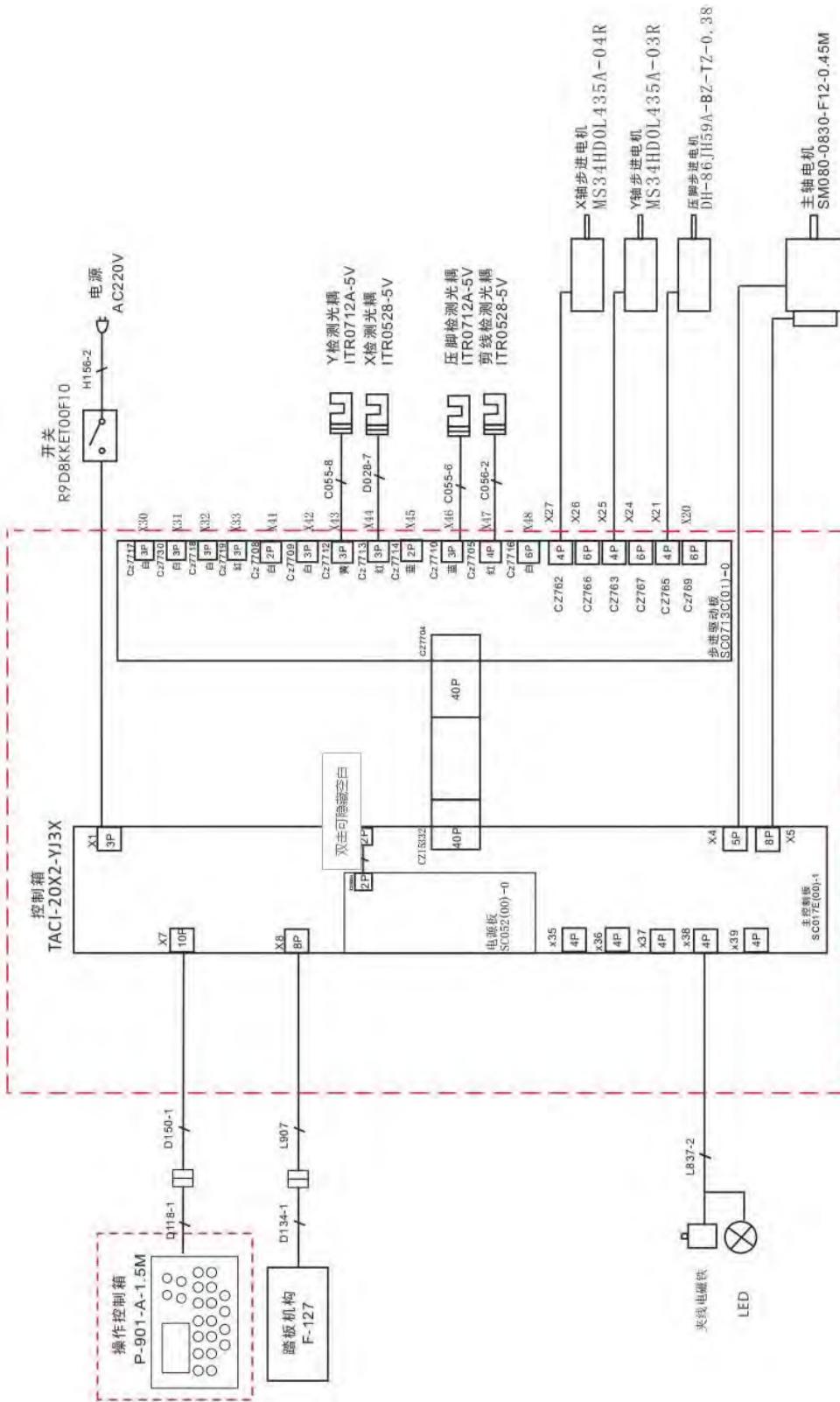

# 1 General Information

## Technical Parameters of 1900D

No.	TYPE ITEM	1900D
1	Purpose	Bartacking/Button Lockstitch
2	Sewing Area	X(lateral)direction40mm×Y(longitudinal)direction30mm
3	Max.SewingSpeed	3300rpm ( 3000rpmforMSC )
4	StitchLength	0.1mm – 10.0mm(adjustableby0.1mm)
5	ClothFeed	IntermittentFeed(2-axisdrivebypulsemotor)
6	NeedleBarStroke	41.2mm
7	Needle	DP×5#14(DP×5#11(F,M),(DP×17#21thickcloth))
8	TypeofLifting PresserFoot	Drivenbypulsemotor
9	HeightofPresser Foot	14mm(Standard),Max. 17mm
10	TotalNumber of StandardPatterns	100
11	WiperType	ToworktogetherwithPresserFootdrivenbyPulseMotor
12	ThreadCatching Device	Standard:0
13	NeedleThread Tension	ElectricalThreadTensionRelease
14	Shuttle	StandardSemi-rotaryHookorSemi-rotaryDoubleHook
15	LubricatingMethod	RotaryPart:Lubricatewithminimumamount
16	LubricatingOil (Liquid)	OrdinarySewingMachineLubricatingOil(Liquid)
17	Grease	OrdinarySewingMachineGrease
18	DataMemory	FlashMemory
19	ScalingFacility	20%~200%(by1%)inXdirectionandYdirectionrespectively
20	ScalingMethod	Byincreasing/decreasingthestitchlength
21	Max.SewingSpeed Limitation	400-3300rpm(by100rpm)
22	PatternSelection	SpecifyingPatternNo.Type(1-200)
23	BobbinThread Counter	Up/DownType(0 – 99999)
24	SewingMachine Motor	500WCompactACServomotor(DirectDrive)
25	Dimensions	305mm×223mm×80mm
26	Weight	10Kg
27	RatedPower	600W
28	Operation	0°C-45°C

	Temperature Range	
29	Operation Humidity Range	35%-85% ( NoDewCondensation )
30	Line Voltage	AC220V±10%;50-60Hz

Please reduce the max. sewing speed in accordance with these sewing conditions.

Effective standard for product: QCYXDK0004—2022 “Computerized Control System for Industrial Sewing Machine”

### Corresponding Machine Type

MSC1900D/MASC1900D electronic bar-tacking and button sewing machine

### Input Mode

Use keys to input.

### Display Method

Use black and white lattice LCD and LED to display all the information.

### Panel Layout

The quadrangle panel can be divided into two parts, the display part and the operation part. The display part consists of 1 lattice LCD and 2 LEDs and the operation part consists of 17 keys. Refer to the picture of the panel.

### Standardization

The function keys use standard images recognizable and popular within the industry. Image is an international language that can be understood by any nation.

### Operation Mode

Function keys include READY key, RESET key, MODE key, THREADING/WINDING key, SELECTION key, UP/DOWN key, EDIT key, RETURN key and other keys for special functions. See operation instruction for detailed operating methods.

## 2 Operation and Debugging

### Instructions of Operation Panel

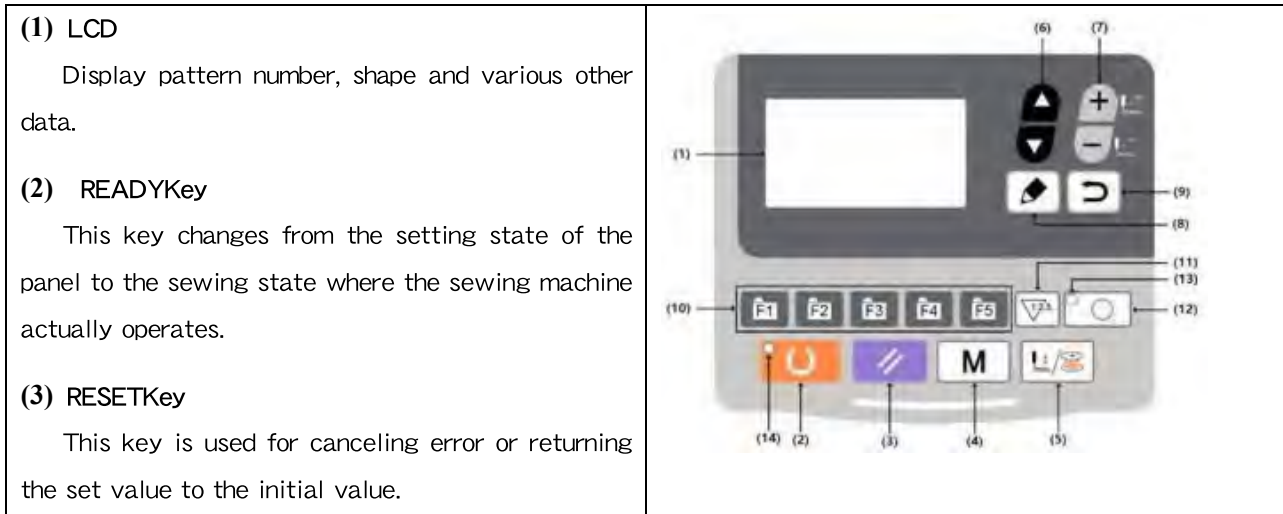

**(4) MODE Key**

This key initiates the setting of parameters or stored patterns.

**(5) PRESSER FOOT/WINDING Key**

This key is used to lift or lower the presser foot. When presser foot is up, move the needle bar back to origin; when the presser foot is down, move the needle bar to the right. Press this key when winding.

**(6) SELECTION Key**

This key is used to select among various pattern types, menu items or parameters.

**(7) DATA SETTING Key**

This key is used to modify the pattern number or parameter value. Under trial sewing mode, this key is used to move single needle and feed cloth.

**(8) EDIT Key**

This key is used to display editing interface, select item or display detailed information.

**(9) RETURN Key**

This key is used to return to the previous interface.

**(10) DIRECT PATTERN (P Pattern)**

Register P patterns. After registration, press the key to make immediate selection for sewing.

**(11) COUNTER Key**

Under sewing editing mode (unready for sewing), press it to enter counter setting mode.

**(12) SPECIAL FUNCTION Key**

This key is used to realize special functions according to setting.

**(13) SPECIAL FUNCTION LED**

LED lights up when entering special function.

**(14) SEWING LED**

Under sewing mode, LED lights up.

## Installing the Main Shaft Motor

Assemble the main motor to the main shaft through the coupling. And you need 4 screws to fix the coupling to the upper shaft and the main shaft. Fix the coupling with No.1 Screw and make sure that it is vertical towards the Flat Section, and then screw No.2 screw. Fix the coupling to the main shaft motor with No.3 screw, and make sure it is vertical to the flat section of the main shaft motor. Then screw the No.4 screw to finish the assembling task. The right diagram shows you the details:

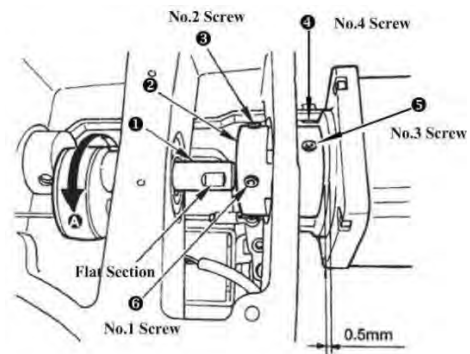

This right diagram shows you the directions of external cables of the main shaft motor (look from back, and the line is on your left-hand side):

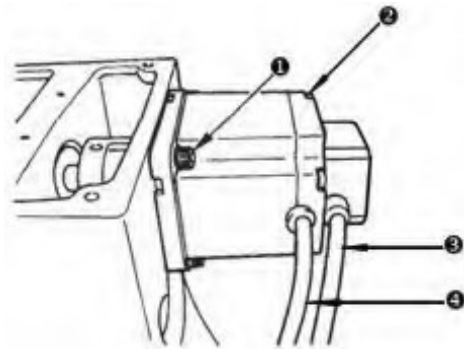

Screws for fixing the main shaft motor, totally 4;  
Screws for fixing the back cover of the motor, totally 4;  
main shaft motor encoder signal cable;  
power line for the main shaft motor.





## Text Mode

This mode is activated to conduct maintenance operation.

1) When the sewing LED is off, hold pressing

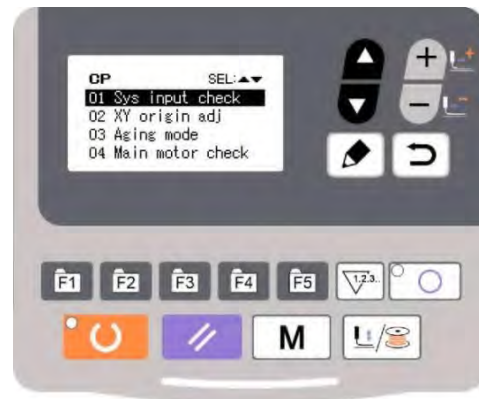

**M** key for 3 seconds, and you would hear the ring of the buzzer. Then select item "11 system test" by pressing  key and press  key to enter test mode.





2) Press  key to change the function item for test and press  key to enter the item for test. The functions represented by each number are as follows:

Function Test Item	Function	Description
01 System Input Test	Input signal test	LED light as the indicator to show the status of sensor input
02 XY Origin Adjustment	XY motor/origin sensor test	Display inching operation, origin searching operation and the status of X/Y origin sensor of X/Y motor
03 Aging Mode	Continuous running	Change to continuous running mode after setting the conditions of continuous running

04MainShaftTest	Mainmotorrotationnumber test	Setuptherotationnumber,startmachineanddisplay theactualrotationnumber.
06PresserFootMotor Test	Presser foot, thread-trimming motor/originsensortest	Displayinchingoperationofpresserfootand thread-trimmingmotor,originsearchingoperationand the status of presser foot origin/presser foot sensor.
08SystemOutput Test	Outputsignaltest	Drivethemovementofoutputsolenoid/airvalve.
09PanelTest	LEDandLCDtest	TestthestatusofpaneldisplayerandLED light.

During the function test, if user presses  key or  key, the test will be terminated and the system will return to the status of step 2); however, if the aging mode has been used once, the aging mode can't be released unless the power supply is shut off.

### 01System InputTest

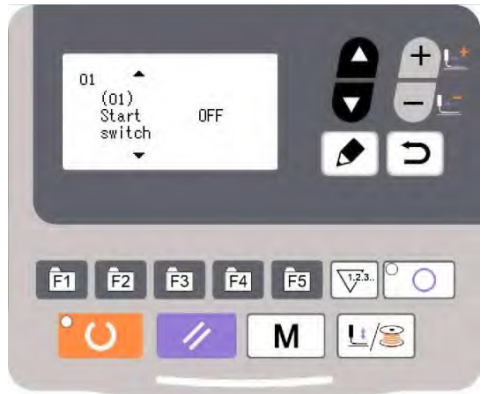
<p>1) Thisfunctionisusedtotesttheinputstatusof panel keys, pedal switch and various sensors.</p> <p>Select “01SystemInputTest” andpress  key to enter.</p> <p>2) Under this mode, press  key to change test itemandthestatusofthetestsignalisdisplayed at the right side of the screen.</p>	
--	---

### 02XYOriginAdjustment

Thisfunctionistodisplaytheinchingoperation,originsearchingoperationandthestatusofX/Yoriginsensor of X/Y motor.

1) XYMotorSingleStepRunningTest

If after machine start, user has never pressed  key to enter ready status but rather

directly pressed  key to enter system test mode, enter “02 XY Origin Adjustment” and





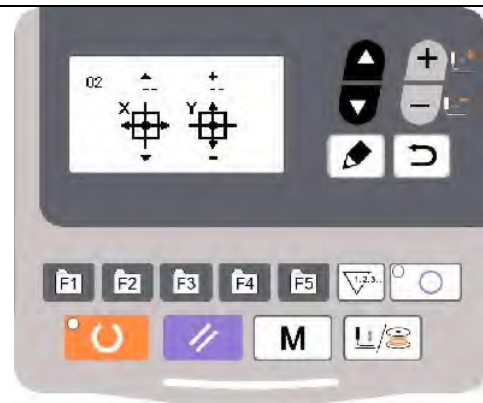

then user can directly press  key and  key to move XY motors step by step

respectively. If user has ever pressed  key to enter ready status after machine start, every time user enters “02 XY Origin Adjustment”

mode, user needs to press  key to search XY origin before moving motor step by step. Under this situation, this item indicates XY motor origin adjustment function.

During moving XY motors, if the signal of the origin sensor changes, the icon displayed on the

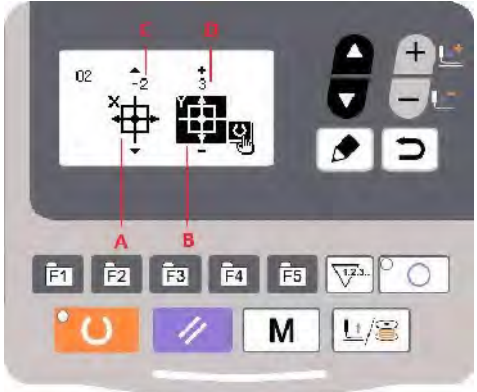

<p>screen will become shadowed.</p>	
<p>2) XYMotorOriginAdjustment</p> <p>First press  key to conduct XY origin search. On the screen will be displayed the origin sensor status A of X motor and the current adjustment value C, as well as the origin sensor status B of Y motor and the current adjustment value D.</p> <p>Press the  key and  key to move X/Y motors respectively step by step and the adjustment value will change simultaneously. Observe the center of the presser foot and the position of needle hole. When they overlap, press  key to save the adjustment value and return. If user doesn't want to save the adjustment value, press  key or  key to give up the saving.</p>	

### 03 Aging Mode

After selecting "03 aging mode", press  key to enter continuous running mode. After setting its conditions, activate the continuous running mode; turn off the power to release the continuous running mode.

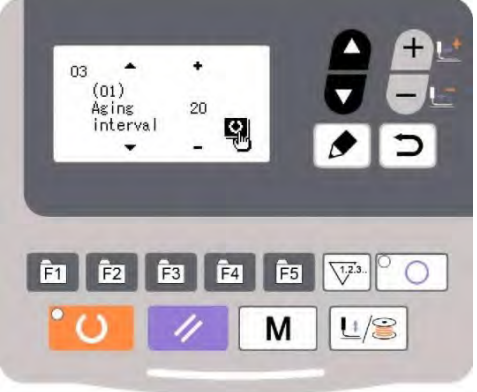
<p>1) IntervalTimeSetting</p> <p>When the screen displays "(01)aging interval", press  key to set the interval time between two operations. This setting range: 0~9900ms (by an increment of 100ms); default value: 2000ms.</p>	
--	--

### 2) OriginSearchatSewingEnd

Press  key to shift to "(02)origin search" to set the origin search at sewing end. OFF: invalid (default)  
ON: valid (origin search at each sewing end)

After setting, press  key to save and enter the main interface of normal sewing mode.



### 3) Continuous Operation

Under sewing mode of normal patterns, user can set pattern No., X/Y scale rate, max. rotation speed and other conditions before starting sewing. At sewing end, if the origin search is set to be valid in step 2, the system







will conduct the origin search of X/Y presser foot and thread-catching/trimming motors. After the set interval time, the system will automatically start sewing again. If user need stop continuous sewing, press  key at sewing end to pause and turn off the power to terminate the continuous sewing.

#### 04 Main Shaft Detection

Set the rotation speed of the machine, and then drive the main motor of the machine to display the actual rotation speed under the set rotation speed.



<p>1) Preparation</p> <p>Select "04 main shaft detection" and then press  key to enter. Each motor will automatically execute origin research. The screen will display the "target rotation speed", "actual rotation speed" and "main shaft angle" of the main shaft motor.</p>	
--	--

#### 2) Operation

Press  key to change the target rotation speed of the main shaft, and then press  key to operate the machine at the set rotation speed. If the set rotation speed need changing, user can continue pressing  key during the operation to set the rotation speed and then press  key again to operate the machine at the new set rotation speed. Press  key to stop the machine. After machine stops, press  key or  key to quit.





#### 06 Presser Foot Motor Detection

This function can be used to display the inching operation, origin search operation of the presser foot/thread-trimming motors and the status of presser foot origin sensor and thread-trimming sensor.

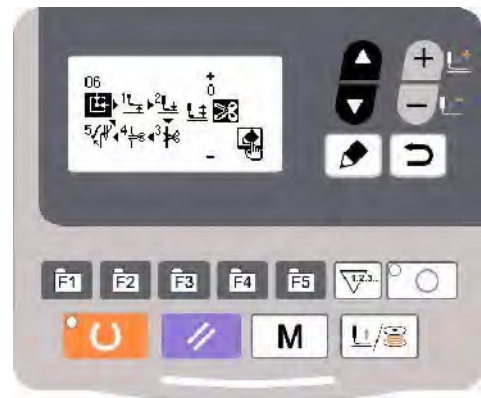
<p>1) Presser Foot Motor Running Test</p> <p>The operation is similar to [2.3.202 XY]. If the machine has entered sewing ready status after power on, user can just enter "06 presser foot motor test" and press  key to execute single step movement test of presser foot motor. At that time, the screen will display the signal status of the two sensors at the presser foot origin position and cutter position. Once origin search is made, user need step pedal to level 2 to execute origin search before removing the motor.</p>	
--	--

2) Simulation Operation Test of Presser Foot Motor  
 Under this mode, step the pedal to level 2 to execute origin search, and then press  key to make simulation operation of the motor at various work operation such as lifting up or lowering down.



3) Presser Foot Motor Origin Adjustment  
 Under this mode, step the pedal to level 2 to execute the origin search. Without pressing  key, the motor will remain at the origin position A. Press  key to change the origin adjustment value D, and at the same time presser foot origin sensor signal B and cutter position sensor signal D will change correspondingly.  
 After setting the value, press  key to save and return. User can also press  key or  key to quit saving and return.

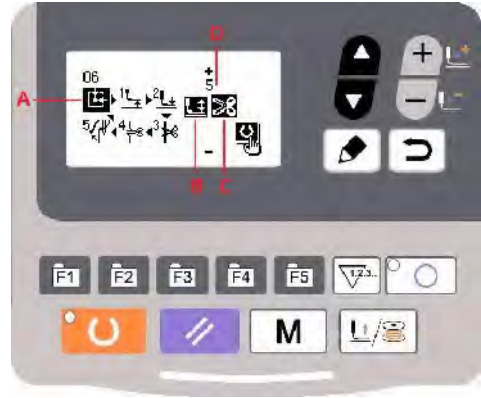

### 08 System Output Test



Under this mode, press  key to shift and select the device to be tested, and press  key to drive that device.

### 09 Panel Test

Under this test, press  key to light up all LED lights on the panel and the full screen of LCD, and press  key to return to normal display status.

## Basic Operations

### Pattern Number Setting

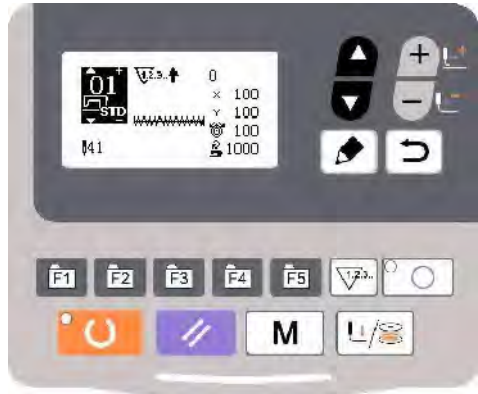





<p>Open powerswitch.</p> <p>On the left upper side of the screen will be displayed the pattern No., as well as pattern shape, X/Y scale rate, thread tension and sewing speed.</p> <p>Press  key to change pattern No. and press  key to shift pattern mode, that is, memory pattern, P pattern and C cyclic pattern.</p>	
---	--







### Item Data Setting

Press  key and the item data input interface will be displayed.

On the left side is the item to be edited and on the right side is the content of setting.

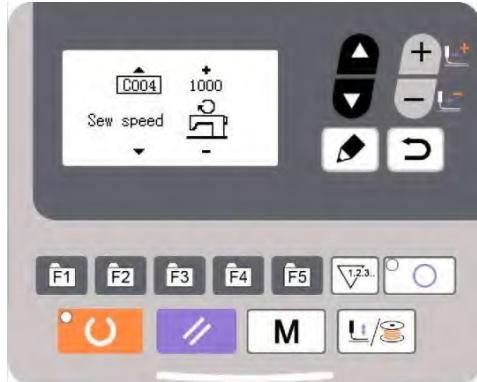
Press  key to select item, press  key to change the content and press  to save and return.

<p>(1) X Size Input</p> <p>Press  to display C001 X size.</p> <p>Press  key to display the intended value.</p> <p>X/Y size can be inputted by % or by actual size (set by parameter U063) and the default setting is % input.</p> <p>Note: if the set value is beyond the sewing range allowed by the presser foot, the needle may collide with the presser foot and thus cause needle breakage which is very dangerous.</p>	
<p>(2) Y Size Input</p> <p>Press  to display C002 Y size.</p> <p>Press  key to display the intended value.</p> <p>X/Y size can be inputted by % or by actual size (set by parameter U063) and the default setting is % input.</p> <p>Note: if the set value is beyond the sewing range allowed by the presser foot, the needle may collide with the presser foot and thus cause needle breakage which is very dangerous.</p>	

<p>(3) Sewing Speed Input</p> <p>Press  key to display C004 sewing speed. Press  key to display the intended value.</p> <p>The inputted value is limited by the max. sewing speed set by parameter U001.</p>	
<p>(4) Thread Tension Setting</p> <p>Press  key to display C003 thread tension.</p> <p>Press  key to display the intended value. (input range: 0~200)</p> <p>Press  to confirm and return to the input interface.</p>	

### (5) Setting Completion

Press  key.

Presser foot moves and lifts and sewing LED lights up to enter sewing status.

Note: press READY key and the presser foot will return to the sewing start. The presser foot will lower down before moving. Therefore, please watch your fingers.

\* Press  key to save the set value of pattern No., XY scalarate, etc.

\* Press  key again, and sewing LED will be off. At that time, user can change the setting of each item.







\* Please confirm the pattern No. first. Otherwise, press  key will initiate error M-306. At that time, user need reset the pattern No.

Note: if user turns off power before pressing  key, the set value of pattern No., XY scalarate, max. rotation speed and thread tension will not be saved.

#### Pattern Shape Confirmation

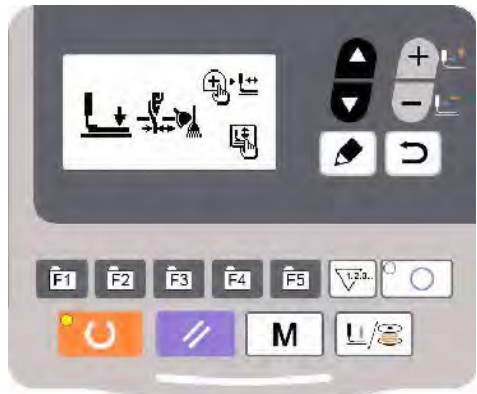
Warning!



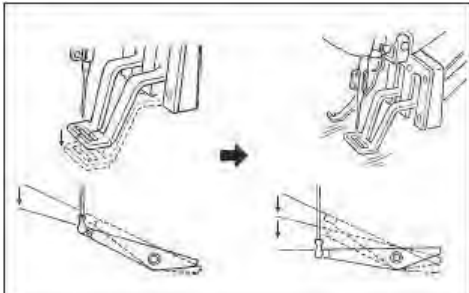

1. After selecting the pattern, user must confirm the pattern shape. If the pattern shape is away from the presser foot, the needle may collide with the presser foot and break.
2. When confirming the pattern shape, please note that if user press +/- keys when the needle bar is down, the needle bar will lift automatically before the presser foot moves.

<p>1) Press  key and sewing LED will light up.</p> <p>2) Press  key to display “presser foot lowering interface” .</p> <p>3) Press  key to display the shape confirmation interface.</p> <p>Under this mode, to step the pedal will not start sewing.</p>	
<p>4) Press  key to confirm the pattern is within the range of presser foot.</p> <p>5) Press  key to return to sewing start position and lift the presser foot.</p> <p>Press  key to display the sewing interface at the present position.</p> <p>At that time, to step the pedal will start sewing from the present position.</p>	









## Sewing

<p><b>Sewing:</b></p> <ol style="list-style-type: none"> <li>1. Put sewing material under presser foot.</li> <li>2. Step pedal to level 1 to lower the presser foot and release the pedal to lift the presser foot.</li> <li>3. Step pedal to level 2 to start sewing.</li> <li>4. At sewing end, presser foot will lift and return to sewing start.</li> </ol>	
---	--

## Change to Other Pattern







<p>Press  key and sewing LED is off.</p> <p>Press  key to set pattern No.</p> <p>XY scale rate, speed, etc. can be set in the same way as [2.4.1 item data setting].</p> <p>Press  key and sewing LED lights up to enter sewing status.</p> <p>Please confirm the pattern shape after pattern selection, in case the pattern is away from presser foot and needle will collide with presser foot and break during sewing.</p>	
--	--





## BobbinThreadWinding

<ol style="list-style-type: none"> <li>1) Press  key and sewing LED is off.</li> <li>2) Press  key to lower the presser foot.</li> <li>3) Press  key to display winding interface.</li> <li>4) Step the pedal to run the sewing machine.</li> <li>5) Step the pedal again or press  key to stop the sewing machine.</li> </ol>	
<ol style="list-style-type: none"> <li>6) Press  key and  key to finish the winding interface.</li> </ol> <p>Note: when just power on, the winding function is inactive. Please set pattern No. or make other operations first and then press  key to search origin before the winding operation.</p>	

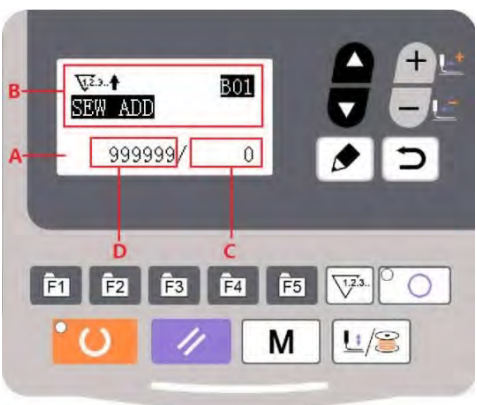
## Sewing with Counter

### (1) Counter Setting Method

<ol style="list-style-type: none"> <li>1) Enter counter setting interface Under input mode, when sewing LED is off, press  key to display the mode interface. Press  key to select "02 counter setting". Press  key to display counter interface A. Or, under input mode, when sewing LED is off, press  key to directly enter counter interface A.  When counter interface A is displayed, counter can be set under input mode. If the system is under sewing mode, press  key to turn off the sewing LED.</li> <li>2) Select counter type</li> </ol>	 
---	--

 Press  key to shadow the counter type icon  B. Press  key to select the proper counter type.	
--	--

### 3) Change counter value

Press  key to shadow the counter value C. Press  key to input the set value.

### 4) Change the present counter value

Press  key to shadow present counter value D. Press  key to clear the present counter value and press  key to edit the present value.

## (2) CounterType

### B01 Sewing Plus Counter

The present value will add 1 after sewing 1 shape. Present value and set value.

### B02 Sewing Minus Counter

The present value will deduce 1 after sewing 1 shape.

When present value reaches 0, minus counter interface will be displayed. B03

### B03 Piece Number Plus Counter

Calculate present value of 1 cyclic sewing by adding number. When present value equals with set value, counter interface will be displayed.

### B04 Piece Number Minus Counter

Calculate present value of 1 cyclic sewing by deducing number. When present value reaches 0, counter interface will be displayed.

### B05 Bobbin Thread Plus Counter

Add to the present value after every 10 stitches. When present value equals set value, counter interface will be displayed.

### B06 Bobbin Thread Minus Counter

Deduct the present value after every 10 stitches. When present value reaches 0, counter interface will be displayed.

### B07 Counter Nonuse

## (3) CounterRelease



When the counter value is exhausted, counter interface will be displayed. Press  key to reset the counter and then the counter will start counting again.



## Pause



### (1) Emergency Stop by Pedal

Pedal has three levels: level 1 to lower the presser foot, level 2 to start sewing and level 3 (to step backward with heel) for emergency stop.

- 1) Press the READY key and then step forward  the pedal to lower the presser foot;
- 2) Step forward  the pedal again to start sewing;
- 3) During sewing, user can step backward  the pedal to stop the machine emergently and the panel will display "E-002".



### (2) Emergency Stop by Panel

- 1) Use parameter U031 to set the RESET key as 1 and the RESET key will be changed into pause key to stop the machine during sewing.
- 2) Press  to stop the machine and "E-002" will be displayed. Press  key again to release the error and the interface to feed cloth forward/backward will be displayed.



3) Then, 3 operations are available:

1. Use starting switch to start sewing.

2. Press  key to trim thread and use  key to adjust position. Then use starting switch to start sewing.

3. Press  key to trim the thread and press  key again to return to origin.

4. After pressing RESET key to trim thread, user can step the pedal again to continue sewing.

### PPattern and CPattern Setting

#### Use Pattern Key to Sew









User can register patterns (No.1~200) to P1~P99. Patterns can be registered after changing scale rate, max. rotation speed, thread tension and sewing position. User can also use pattern No. rolling window to register pattern. P1~P25 can be displayed at the same time.









\*When selecting P6~P25, user can use the combination of  keys (press simultaneously) to sew.

P-No.	SelectionKey	P-No.	SelectionKey	P-No.	SelectionKey	P-No.	SelectionKey
P1	P1	P8	P1+P4	P15	P4+P5	P22	P2+P3+P4
P2	P2	P9	P1+P5	P16	P1+P2+P3	P23	P2+P3+P5
P3	P3	P10	P2+P3	P17	P1+P2+P4	P24	P2+P4+P5
P4	P4	P11	P2+P4	P18	P1+P2+P5	P25	P3+P4+P5
P5	P5	P12	P2+P5	P19	P1+P3+P4		
P6	P1+P2	P13	P3+P4	P20	P1+P3+P5		
P7	P1+P3	P14	P3+P5	P21	P1+P4+P5		

#### (1) Register to Pattern Key

Example: register pattern No.3 to P2, with X scale rate as 50%, max. speed of 2000 sti/min, thread tension as 50 and pattern position as 0.5mm to the right and 1mm forward.

<p>1) Turn on the power and then press  key. (Sewing LED is off.) Enter mode setting (memory switch setting). Press  key to select "04 register P pattern" and press  key to enter pattern register mode.</p>	
<p>2) Press  key to set the standard pattern as No.3. Press  to set P-No. as 2. Press READY key to register P2 and the mode interface will be displayed. Then press  key or  key.</p>	

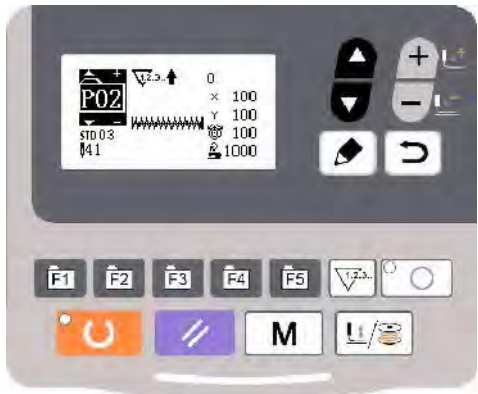
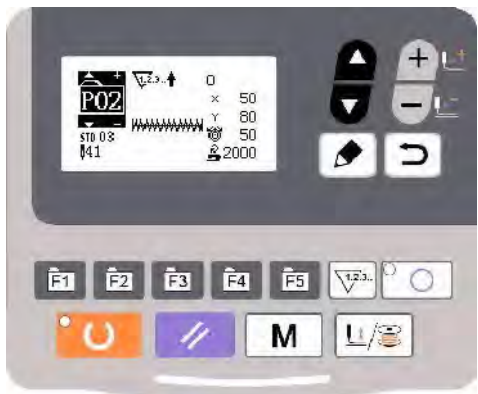

<p>3) Press  key and then press  key to edit item data.</p> <p>4) Set separately the X scale rate as 50%, Y scale rate as 80%, sewing speed as 2000 sti/min and thread tension as 50.</p> <p>5) Press  key and X scale rate will be displayed as 0.0. The increment of X direction movement can be set as 0.1mm. Press  key to change the data into 0.5.</p> <p>6) Press  key and X scale rate will be displayed as 0.0. The increment of X direction movement can be set as 0.1mm. Press  key to change the data into 1.0.</p> <p>7) Press  key to complete setting.</p> <p>8) Press  key to complete pattern registering method.</p> <p>9) Press  key to complete setting and return to normal mode.</p>	 
--	---

### Group Sewing (Cyclic Sewing)

This machine can be used to sew several patterns in order cyclically.

Up to 99 patterns can be inputted. In addition, 99 data of group sewing can be registered. If necessary, please make a copy for future use.

#### (1) Cyclic Data Selection

<p>1) Set as input mode</p> <p>Under input mode, when sewing LED is off, select cyclic sewing data. If the system is under sewing mode, press  key to change into input mode. The cyclic sewing data can only be selected under data mode.</p>	
---	--



2) Select cyclic sewing data

Press  key to shift among the registered cyclic sewing data No. and continuous sewing data No. At this time, user can select the intended cyclic sewing No.

### 3) Conduct sewing



After selecting the continuous sewing data, press  key and sewing LED lights up, ready for sewing. Only cyclic data No.1 is registered without sewing patterns and therefore cannot be used for sewing. Please follow the following editing method to input patterns.

## (2) Cyclic Sewing Data Editing Method

<p>1) Set as input mode Under input mode, when sewing LED is off, user can input continuous sewing data. If the machine is under sewing mode, press  key to change into input mode.</p> <p>2) Set cyclic sewing data as editing status Press  key to enter editing status and the selected pattern No. for editing will become shadowed. At that time, data can be edited.</p>	
--	--

### 3) Selected editing content

Press  key to change the editing content and when moved to the last pattern, user can add patterns.

After selecting the editing content, press  key to display the icon  which means pattern data can be inserted.

### 4) Changed data of editing content



Press  key to change data of the editing content. The registered pattern No. will be displayed for editing.

Press  key to delete the pattern data. User can repeat steps 3 and 4 to edit data.

### 5) Cancel pattern data input

Press  key to cancel pattern data input and return to input mode.













## (3) Sewing Operation

<p>1) Turn on the power.</p> <p>2) Press  key to select cyclic pattern and press  key to select the pattern No.</p> <p>3) Press  key and sewing LED lights up. Presser foot will move and then lift.</p>	
---	--







### Copy/Delete P Pattern and C Pattern

Registered P patterns can be copied into new P patterns, so are C patterns. Existing P patterns or C patterns can also be deleted (the last C pattern cannot be deleted).











### Copy/Delete P Pattern

<p>1) When sewing LED is off, press  key to enter system menu, press  key to select “05 copy/delete P pattern” and then press  key to enter this mode.</p>	
<p>2) Press  key to shift to the P pattern number (existing) to be copied, and press  key to shift to a new P pattern number (new). After confirmation, press  key to save and return. Press  key to quit saving and return.</p>	
<p>3) When pressing  to shift to new P pattern number, user can select icon , and if user presses  at that time, the existing P pattern will be deleted.</p>	

## Copy/Delete C Pattern

<p>1) Under the system menu, press  key to select “06 copy/delete C pattern” and press  key to enter this mode.</p> <p>2) Similar to the operation to copy/delete P pattern, press  key to shift new C pattern number to execute copying operation or press  key to delete C pattern.</p> <p>When press  key to shift to the icon , it means to register a new empty C pattern.</p>	
---	--

## Memory Switch Activation and Change

<p>1) Set input mode When sewing LED is off, memory switch data can be changed. Under sewing mode, press  key to shift to input mode.</p> <p>2) Enter data editing interface Press  key to display the mode interface (operator level). Press  key to select “01 U parameter” and press  key to enter memory switch data interface.</p>	
<p>3) Select data to be changed Press  key to select the data item to be changed.</p> <p>4) Change data Press  key to increase or decrease the set value.</p> <p>5) Save and quit After completing data change, press  key to save and quit, and return to mode interface. Press  key again to return to sewing interface.</p>	

## UserParameterSettingList

No.	Function	AdjustmentRang	Default Value	Remarks
U001	MaxSpeedofSewing ( Itcanbesetbyanincrementof 100rpm )	400~3000	3000	
U002	Sewingspeedof1 <sup>st</sup> Stitch (thread-catching) (Itcanbesetbyanincrementof 100rpm)	400~1500	1500	
U003	Sewingspeedof2 <sup>nd</sup> Stitch (thread-catching) (Itcanbesetbyanincrementof 100rpm)	400~3000	3000	
U004	Sewingspeedof3 <sup>rd</sup> Stitch (thread-catching) (Itcanbesetbyanincrementof 100rpm)	400~3000	3000	
U005	Sewingspeedof4 <sup>th</sup> Stitch (thread-catching) (Itcanbesetbyanincrementof 100rpm)	400~3000	3000	
U006	Sewingspeedof5 <sup>th</sup> Stitch (thread-catching) (Itcanbesetbyanincrementof 100rpm)	400~3000	3000	
U007	Threaddensionof1 <sup>st</sup> Stitch (thread-catching)	0~200	200	
U008	Threaddensionatthetimeof thread-trimming	0~200	0	
U009	Changeovertimeofthreaddension atthread-trimming	-6~4	0	
U010	Sewingspeedof1 <sup>st</sup> Stitch(no thread-catching) (Itcanbesetbyanincrementof 100rpm)	400~1500	400	
U011	Sewingspeedof2 <sup>nd</sup> Stitch(no thread-catching) (Itcanbesetbyanincrementof 100rpm)	400~3000	900	
U012	Sewingspeedof3 <sup>rd</sup> Stitch(no thread-catching) (Itcanbesetbyanincrementof 100rpm)	400~3000	3000	
U013	Sewingspeedof4 <sup>th</sup> Stitch(no thread-catching)	400~3000	3000	

	thread-catching) (Itcanbesetbyanincrementof 100rpm)			
U014	Sewingspeedof5 <sup>th</sup> Stitch(no thread-catching) (Itcanbesetbyanincrementof 100rpm)	400~3000	3000	
U015	Threadtensionof1 <sup>st</sup> Stitch(no thread-catching)	0~200	0	
U016	Changeover timing of thread tensionatthesewingstart(no thread-catching)	-5~2	0	
U025	PresserFootDivision	0:Divided 1:Notdivided	1	
U026	Adjustmentofpresserfootheight insectionlevel2	50~90	70	
U031	Usekeyboard(ClearKey)to stop sewing machine	0: invalid 1:RESETkey 2:Externalemergencystop	0	
U032	Buzzerforbidden	0:no voice 1: panel operation voice2:paneloperationvoice and alarmvoice	2	
U033	Setnumberofstitches that thread-catchingreleases	1~7stitches	2	
U034	Timedeferrableincatching thread	-20~0	0	
U035	Forbidthecontrolon catching upperthread	0:Normal 1:Forbidden	1	
U036	SelecttheFeedtime. When stitches are not well tightened,setthevaluein “ - ” direction.	-8~16	12	
U037	Presserfootstatusat sewingend	0:Backtosewingstartand then lift 1:Backtosewingstartand at the same time lift 2:liftthe presserfootmanually bysteppingthe pedal	1	
U038	Whenthepresserfoot doesn't lift, sewing can only be done by starting switch	0: Normal 1:Forbidden tolift presser foot	0	
U039	Searchoriginat sewing end	0:Notsearch origin 1:SearchOrigin	0	
U040	Searchoriginat cyclicsewing	0:NotSearch origin 1:Searchorigin afterthe finish	0	

		ofeachpattern		
U041	SearchoriginatsewingofPpattern	0:Notsearchorigin 1:SearchOrigin	0	
U042	Stoppositionofneedlebar	0:upperposition 1:highestposition	0	
U043	BrightnessofLEDspotlightatthe machine head	0~10	5	The larger value, the brighter;0 means off.
U046	Forbidthread-trimming	0: normal 1:forbidthread-trimming	0	
U049	Setwindingspeed	800~2000	1600	
U055	Forbidstartbartackingatbutton sewing	0:start bartacking 1:nostartbartacking	0	
U063	SettingmethodofX/Yscale rate	0:by percentage 1:by size	0	
U135	Presserfootmovementorder beforesewing	0:stand-byatthesewingstart 1:stand-by attheorigin	0	
U200	Language	Setlanguage	Simplified Chinese	
U212	Airvalveseparatepresserfoot lowering order	0: lower at the same time 1:lowerleftpresserfirstand thenrightpresser 2:lowerrightpresserfirstand then left presser	0	
U213	Airvalveseparatepresserlifting order	0:liftatthesametime 1:liftleftpresserfootfirstand then right presser foot 2:liftrightpresserfootfirst andthenleftpresserfoot	0	
U214	OverturnPresserFootAvailability	0:forbidden 1:available	1	
U245	Clearlubricatingalarmerror	PressRESETto clear	Display the accumulate dnumberof sewn stitches	

### 3 ServiceParameterSetting

Serviceparametersaredifferentfromnormalparametersandusuallyarenotallovedtochangebyusers. Theseparametersarefortechicianstodebugthemachine.

#### ServiceParameterActivationandChange

WhensewingLEDisoff,holdpressing **M** keyfor3secondsuntilthebuzzerringssoastoactivateand

changetheserviceparameter.

Theoperationofserviceparameterchangeisthesamewiththatofnormalparameter,pleasereferto[2.7 memory switch activation and change].

### ServiceParameterList

No.	Function	AdjustmentRange	Default Value	Remarks
K001	PedalType	0:AnalogSinglePedal 1:DigitalSinglePedal 2: Double Pedals 3:DoublePedals,butonly the operation pedal controls	0	
K002	IntermediatePresserFoot Control Method	0:nocontrol 1:not used 2:solenoidcontrol 3:mechanicalcontrol	0	
K019	Liftingtimeofpneumaticouter presserfoot	0~90	30	
K021	Positionsofstandardpedal& pedalswitch	50~200	70	
K022	Positionofstandardpedal& stroke switch of high/low section.	50~200	120	
K023	Positionofstandardpedal& startswitch	50~200	185	
K027	Droppingspeedofpresser foot atdepressingpedal	100~4000pps	4000	
K028	Liftingspeedofpresserfootat steppingpedal	100~4000pps	1500	
K029	Liftingspeedof thread-trimmingpresserfootat sewing end	100~4000pps	3000	
K043	Selectionofmachinerotating numberatthread-trimming	3~8	8	
K044	Selectiononwhethertofeed clothinthedirectionforeasy thread-trimming	0:NotFeed 1:Feed	0	
K045	Guidediameterofneedlehole for feeding cloth at thread-trimming(byan incrementof0.2mm)	16~40 ( 1.6mm~4.0mm )	16	
K056	Limitedrangeofmotionin+X direction(Right)	0~50mm	20	
K057	Limitedrangeofmotionin-X direction(Left)	0~50mm	20	

K058	Limitedrangeofmotionin+Y direction(Back)	0~30mm	15	
K059	Limitedrangeofmotionin-Y direction(Front)	0~30mm	15	
K064	Selectthreadwipingmethod	0: solenoid 1: motor	1	
K066	Impulsenumberforcoactions ofpresserfootand wiper	30~60	45	
K074	Presserfootcontrolmodeshift	0:airvalvecontrol 1:motorcontrol	1	
K095	Thread-trimmingangle	- 10~10	0	
K097	Thread-trimmingmethodat pause	0: automatic thread-trimming 1:manualthread-trimming	1	
K102	Xsteppingmotorfull-current parameter	0~15	7	Effectiveafter restart
K104	Ysteppingmotorfull-current parameter	0~15	11	Effectiveafter restart
K106	Thread-catchingstepping motorfull-currentparameter	0~15	2	Effectiveafter restart
K108	Pressersteppingmotor full-currentparameter	0~15	14	Effectiveafter restart
K109	Xsteppingmotorsemi-current parameter	0~15	7	Effectiveafter restart
K110	Ysteppingmotorsemi-current parameter	0~15	6	Effectiveafter restart
K111	Presserfootsteppingmotor semi-currentparameter	0~15	5	Effectiveafter restart
K112	Mainshaftstopcorrection	- 10~10	0	
K120	Stitchnumberforalarmtoadd lubricating oil	3000~12000	5000	Unit:ten thousand stitches
K121	CounterLock	0:ClearandPlus/Minus; 1: Clear Only; 2:Plus/MinusOnly; 3:NeitherClearnor Plus/Minus	0	
K122	OClengthadjustment	- 128~128	0	
K123	ODlengthadjustment	- 128~128	0	
K124	BDlengthadjustment	- 512~512	0	
K125	OClength	1780~2380	2080	
K126	ODlength	1440~2040	1740	
K127	BDlength	430~630	530	

K128	SteppingDriveType	0:DSP1CloseDSP2Close 1: DSP1 Open DSP2 Open 2:DSP1CloseDSP2 Open 3:DSP1OpenDSP2Open	0	Effectiveafter restart
K135	Thread-separatingdelay	- 10~30	0	
K137	Threadclampreleaseangle at sewingstart	- 150~150	0	
K138	Thread clamp holding time aftertrimmingatsewingstart	-2~1	0	-2 means threadholding action prohibited after thread-trimmi ngatsewing start
K140	ThreadTensionControl Method	0: electronic 1: mechanical	0	
K141	Suctionforceadjustmentof branchthreadtensionsolenoid	- 20~20	0	
K142	Holdingforceadjustmentof branchthreadtensionsolenoid	- 40~40	0	
K150	Invalidityofheadtiltsafety switch	0: Normal 1:The safety status of tilt head is invalid.	0	
K160	Prohibit stepping the pedal backwardforemergencystop	0~1	0	0:Allowed 1:Prohibited
K172	Setstitchnumberforthread breakage detection	0~10	0	Valuebigger than0means the stitch numberafter thread breakage before emergency stop 0 means thread breakage detectionis off.
K174	Sensoravailabilityatthecutter position	0: forbidden 1:inuse	1	
K227	MainShaftMotorType	0:0830-F11 1:0830-F01	0	Effectiveafter restart

K241	FunctionSelection	0:Bar-tacking 5:Patternbar-tacking 7:Buttonsewing	0	
------	-------------------	---	---	--





Note:theaboveparametersarefortheuseofrepairersonlyandusershouldnotchangethemwithout caution.

### RestoreDefaultSetting

If the user changes some parameters by mistake, which are properly set at delivery, the function of “recoveryto default setting” can be used to restore the system.







Atrecoveringthedefaultsettings,theentireparametersthataresetbyuserbeforewillbecovered. Therefore, please take caution in using this function. If necessary, please contact the technicians of the manufacturer, and operate the machine with the instruction from the professionals.

This specific operation procedure is as follows:

When the sewing LED is off, hold pressing  key for 3 seconds until the panel buzzer rings. Press  key to select “13 recovery to default setting”, and then press  key to enter the menu for restoring default setting. Press  key again to select the item to be restored and then press  key to execute the recovery operation. The panel will hint “executing, please do not turn off the machine”, which means the recovery operation is undergoing and the power supply shall not be shut down. When the operation is completed, the panel will hint “please turn off the machine” and then you can shut down the machine and restart it to restore the default setting.

Note: During the restoring process, if the power supply is shut down by accident, the restoring process has to be aborted and you failed to restore the default setting. The software will return to the former state before restoring.

### SoftwareVersionDisplay

When sewing LED  is off, hold pressing  key for 3 seconds until the buzzer sings. Release  key and then press  key to select “08 inquires software version”. Press  key to enter the software version inquiry interface, where user can press  key or  key to select the version to be inquired. The software version will be displayed in the following order:

Main control: machine type-MC-manufacturer code-version number

Operation panel: machine type-LKD2-manufacturer code-version number



Stepping 1: machine type- MD1-manufacturer code-version number

Stepping 2: machine type- MD2-manufacturer code-version number

### CheckTotalNumberofStitchesandClearLubricatingAlarm

After the machine runs for a period of time, the system may hint “M-333 machine needs lubricating”, which means lubricating is needed. Under this situation, press  key first to clear the lubricating alarm, and then

press  to enter system menu. Select “01 system U parameter” and press  key to enter U parameter

setting mode. Then press  key to select “U245 clear stitch number for lubricating” and press  to clear the total number of stitches, to stop displaying the same message.









### Password Setting and U/K Parameter Lock

The system provides users with password management function for them to set password by themselves. After inputting the set password, user can unlock certain advanced functions. User can lock system parameters to prevent change of key parameters by mistake so as not to cause problems.

#### Change Password



If user need change password, first enter password management mode and then change the password by the following method: when sewing LED is off, hold pressing  key for 3 seconds until the buzzer rings, press





 key to select “14 password setting” and press  key to enter password input interface.

<p>Press  key to move backward or forward to delete the password position to be inputted. Press  key to input the password character for the selected position. The available password characters are “0~9”, “A~Z”. After completing input, press  to confirm and enter the new password input interface. Otherwise, the system will report error and return to the system menu.</p> <p><b>Note: the default password is fixed; for more information, please contact your machine manufacturer or its agents.</b></p>	
<p>User need input the new password in the first line and re-input the same password to confirm it. Then press  to confirm the password change. Otherwise, the system will hint “wrong password”. If user will give up the password change operation, press  key or  key to quit.</p> <p><b>Note: after successful change of password, please remember the password and keep it secret!</b></p>	

#### Set U/K Parameter Lock

This function allows user to lock or unlock parameters that need protecting. Every U parameter and K parameter can be set to be locked or unlocked. The setting method is the same for U parameter and K parameter, and here take U parameter lock for example.



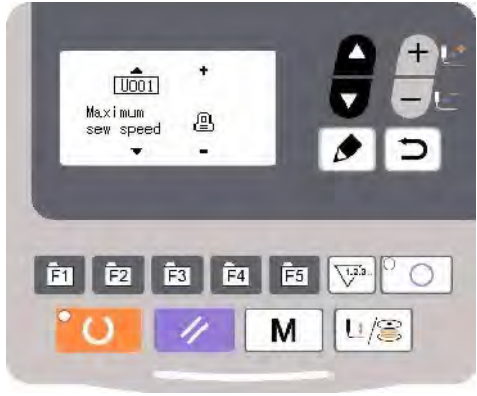



Under the system menu, press  key to select “15 U parameter lock” and press  key to enter password input interface. Input the right password and press  key to enter U parameter lock setting interface. The password has to be correct, otherwise user cannot enter this interface.



<p>Under this interface, press  key to select the U parameter that needs to change its locked/unlocked status, and press  to change the locked/unlocked status. The symbol  means locked and  means unlocked. When parameter is locked, user needs to input password to change its set value. When user quits the parameter setting interface and enters it again, the locked parameters will remain locked.</p>	
--	--

After completing the parameter lock setting, press  key or  key to save and quit.

## 4 Button Sewing Function

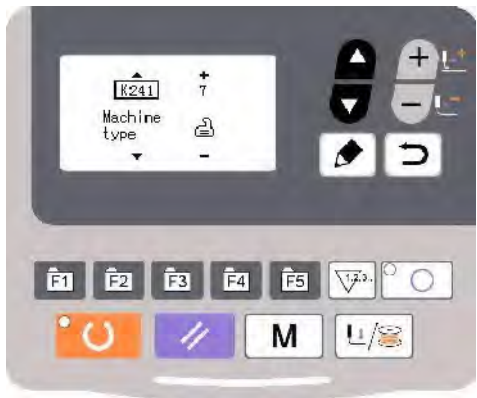
### Button Sewing Function Setting

<p>1、 When sewing LED  is off, hold pressing  key for 3 seconds until the buzzer rings, and release  key to activate service parameter medication;</p> <p>2、 Press  key to select “12 system K parameter”, press  key to enter and then press  key to select parameter K241;</p>	
--	--

3、 Press  key to change the parameter value into “7” and press  key to confirm the change. At this time, the panel will hint “operation executing, please do not turn off the machine”, and user must not cut off the power supply. When the panel hint “please turn off the machine” after a while, user can cut off the power supply.

4、 Then power the machine again and the function changes into button sewing.

Note: the button sewing function of the machine requires special presser foot and other auxiliary external devices. For more information, please contact your machine manufacturer or its agents.

## 5 UpdatePatternData by USB Disk

Support import (addition) of single VDT pattern:

(01) Import pattern: import (add) pattern, and cover the pattern of the same number with imported pattern;

(2) Export pattern: export all external patterns to USB storage device;



(3) Delete pattern: clear (format) the panel's storage area for external patterns;

### Pattern Data Update

User can import VDT format patterns to the control system via U disk, with the updated pattern number from 101 to 200. User can also export existing patterns numbered 101~200 that are stored in the control system to U disk.

- 1) Use pattern-editing software to make pattern file in VDT format and name it by "XXX.VDT". (Note: XXX shall be a number between 101~200 which at the same time is the updated pattern number.)
- 2) Create a new file folder named DH under the root directory of U disk, and save the pattern made in the previous step under the directory of DH (many patterns at one time).



3) When the sewing LED is off, press  key to enter system menu. Press  key to select "10 pattern

import/export" and then press  key to enter this mode.

4) Press  key to select "01 import pattern" and insert the U disk containing patterns to the USB interface at the right side of the panel.

5) Press  key, and when the panel hints "operation executing, please do not turn off the machine", the patterns are starting to be imported.

Note: before this operation, please confirm the U disk has been connected to the USB interface; if not, this update operation cannot be done and the panel will hint "M-324 U disk not found".

6) After the update, the panel will display "Operation succeeded!" and the system will automatically return to the interface for importing patterns.

Note: if there are already patterns numbered 101~200 in the panel, patterns named with different numbers can be added to the system via U disk following the above operations; if the pattern numbers in the U disk are the same with those in the panel, the patterns with the same number in the panel will be replaced.

In addition, apart from the pattern update import operation under function number "01", user can also change the function number to "02" and "03" to export and delete patterns respectively. To change function number to "02" means to back up imported patterns, while to change function number to "03" means to delete all patterns numbered 101~200, which may be done when external pattern storage area is full or the data format of the external pattern storage area is abnormal.

7) Open pattern lock: after update, if the patterns updated via U disk cannot be selected on the sewing interface, the possible reason is that the pattern lock is unopened, for the default setting of patterns number 101~200 is locked and unable to be selected. User need make the following operation:

When sewing LED is off, press **M** to enter

system menu, press  key to select “03 normal pattern lock” and press  key to enter.

Under this mode, the left part A displays the

normal pattern number, and user can press  key to change from 1~200; the right part B display the pattern status, “ON” for open and “OFF” for



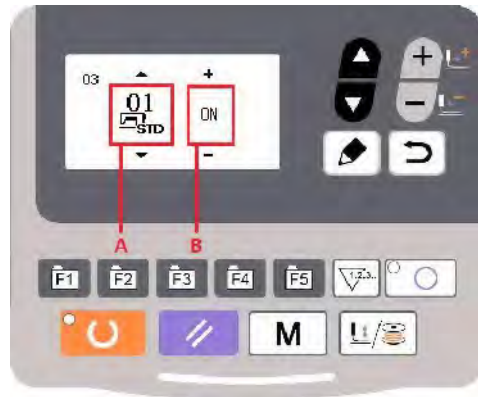







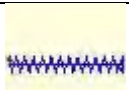

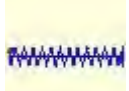

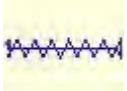

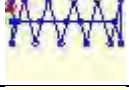

lock. User can press  to open or lock the pattern.



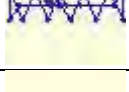

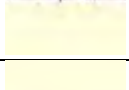
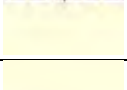
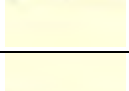
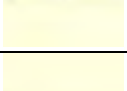
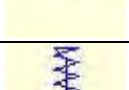

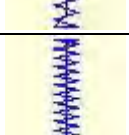
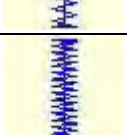



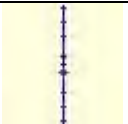
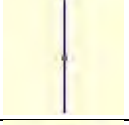
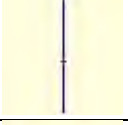

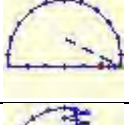
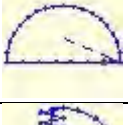

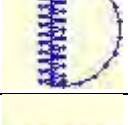
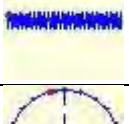

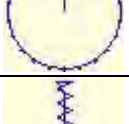

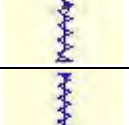
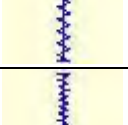
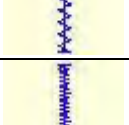
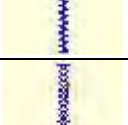
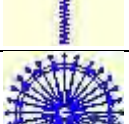
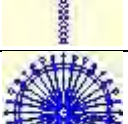
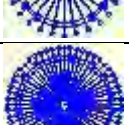
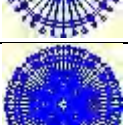
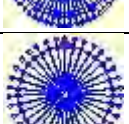
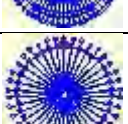



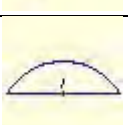
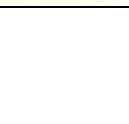
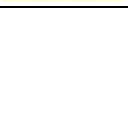

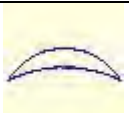



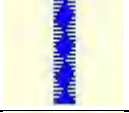



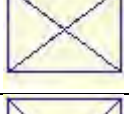
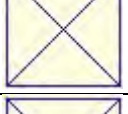
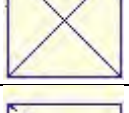
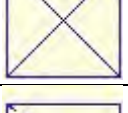

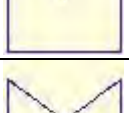

8) Use  key and  key to open the pattern, press  key to save and return to the system menu, and then press  key again to return to the normal sewing mode.

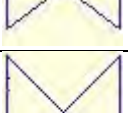

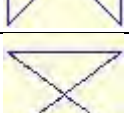

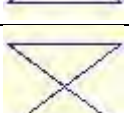
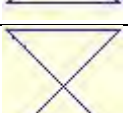

## 6 Appendix 1

List of Patterns in 1900A Controller



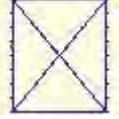
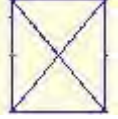
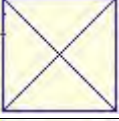
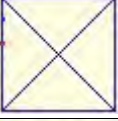
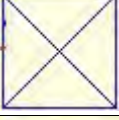

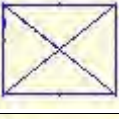
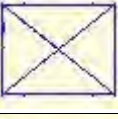
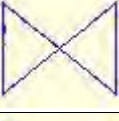
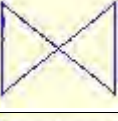

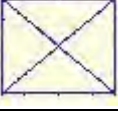



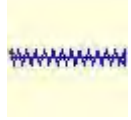

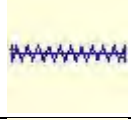
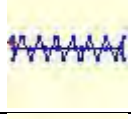
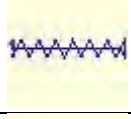
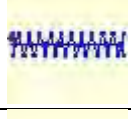
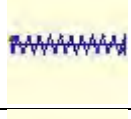
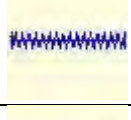
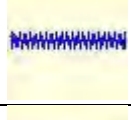
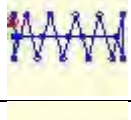
NO	Patterns	Stitch Number	Length×Width (mm)	NO.	Pattern	Stitch Number	Length×Width (mm)
1		41	16.1×2	2		41	10.2×2
3		41	16×2.4	4		41	24×3
5		27	10.1×2	6		27	16×2.4
7		35	10.1×2	8		35	16×2.4
9		55	24×3	10		63	24×3
11		20	6.1×2.4	12		27	6.2×2.4
13		35	6.1×2.4	14		14	8×2
15		20	8×2	16		27	8×2
17		20	10×0	18		27	10×0
19		27	25.2×0	20		35	24.8×0
21		40	25.2×0	22		43	35×0
23		27	4×20	24		35	4×20
25		41	4×20	26		55	4×20



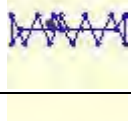
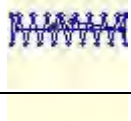
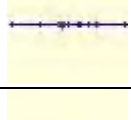
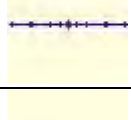
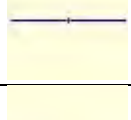
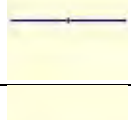
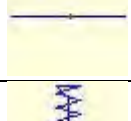
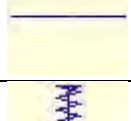
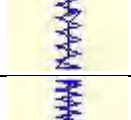
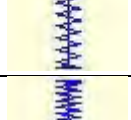

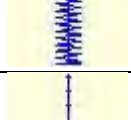

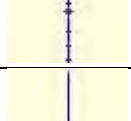





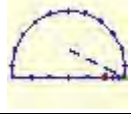





27		17	0x20	28		20	0x10
29		20	0x20	30		27	0x20
31		51	10.1x7	32		62	12.1x7
33		23	10.2x6	34		30	12x6
35		47	7x10	36		47	7x10
37		89	24x3	38		27	8x2
39		25	11.8x12	40		45	12x12
41		28	2.4x20	42		38	2.4x25
43		38	2.4x25	44		57	2.4x30
45		75	2.4x30	46		41	2.4x30
47		89	8x8	48		98	8x8
49		147	8x8	50		163	8x8
51		110	7.9x7.9	52		120	7.9x7.9
53		130	7.9x7.9	54		51	12.4x10.2
55		50	12.4x10.2	56		52	21x6

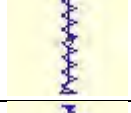
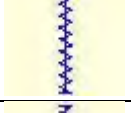
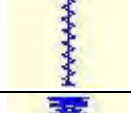
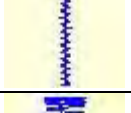
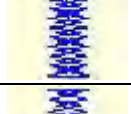
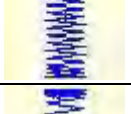

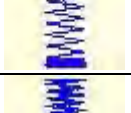
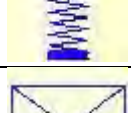
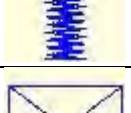

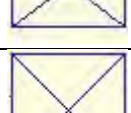
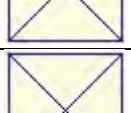
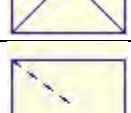
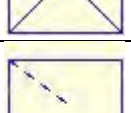





57		57	21×6	58		102	19×3
59		115	40×5	60		115	40×5
61		93	5×30	62		109	5×30
63		108	40×30	64		80	40×30
65		64	40×30	66		96	30×30
67		76	30×30	68		60	30×30
69		52	40×30	70		40	40×30
71		32	40×30	72		44	30×30
73		36	30×30	74		28	30×30
75		60	40×30	76		48	40×30
77		36	40×30	78		56	30×30
79		44	30×30	80		36	30×30
81		67	40×30	82		51	40×30
83		39	40×30	84		55	30×30
85		35	30×30	86		42	30×30

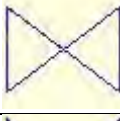
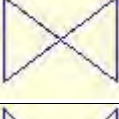
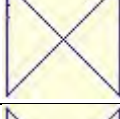
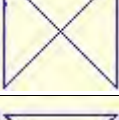
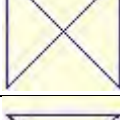
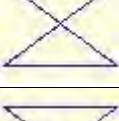
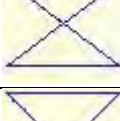
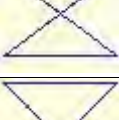

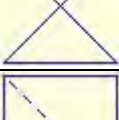
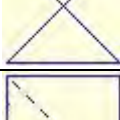
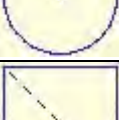
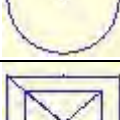
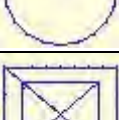
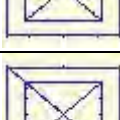
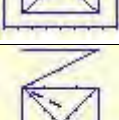
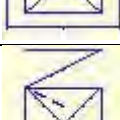
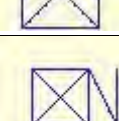
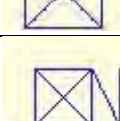
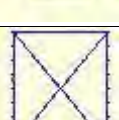
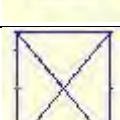

87		32	30.1×30	88		26	30×30
89		74	20×24	90		54	20×24
91		65	20×20	92		49	20×20
93		39	20×20	94		63	25×20
95		51	25×20	96		45	25×20
97		42	25×20	98		33	25×20
99		27	25×20	100		88	30×25



1		41	16.1×2	2		41	10.2×2
3		41	16×2.4	4		41	24×3
5		27	10.1×2	6		27	16×2.4
7		35	10.1×2	8		35	16×2.4
9		55	24×3	10		63	24×3
11		20	6.1×2.4	12		27	6.2×2.4
13		35	6.1×2.4	14		14	8×2
15		20	8×2	16		27	8×2
17		20	10×0	18		27	10×0
19		27	25.2×0	20		35	24.8×0
21		40	25.2×0	22		43	35×0
23		27	4×20	24		35	4×20
25		41	4×20	26		55	4×20
27		17	0×20	28		20	0×10
29		20	0×20	30		27	0×20

31		51	10.1×7	32		62	12.1×7
33		23	10.2×6	34		30	12×6
35		47	7×10	36		47	7×10
37		89	24×3	38		27	8×2
39		25	11.8×12	40		45	12×12
41		28	2.4×20	42		38	2.4×25
43		38	2.4×25	44		57	2.4×30
45		141	10×30	46		122	10×30
47		97	10×30	48		109	10.1×30
49		122	10.1×30	50		265	10×30
51		108	40×30	52		80	40×30
53		64	40×30	54		96	30×30
55		76	30×30	56		60	30×30
57		52	40×30	58		40	40×30
59		32	40×30	60		44	30×30

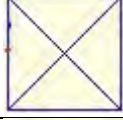
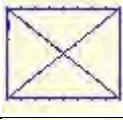
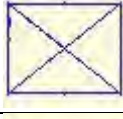
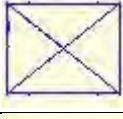
61		36	30x30	62		28	30x30
63		60	40x30	64		48	40x30
65		36	40x30	66		56	30x30
67		44	30x30	68		36	30x30
69		67	40x30	70		51	40x30
71		39	40x30	72		55	30x30
73		43	30x30	74		35	30x30
75		42	30x30	76		32	30.1x30
77		26	30x30	78		103	30x25
79		82	30x25	80		64	30x25
81		80	20x30	82		60	20x30
83		80	30x20	84		60	30x20
85		74	20x24	86		54	20x24
87		115	40x5	88		115	40x5
89		93	5x30	90		109	5x30

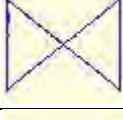
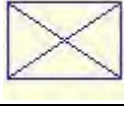
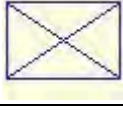
91		65	20x20		92		49	20x20
93		39	20x20		94		63	25x20
95		51	25x20		96		45	25x20
97		42	25x20		98		33	25x20
99		111	60x40		100		91	60x40

### MainControlErrorList

Code	Name	Content	Solution
E-001	Pedal not in the middle position	Pedal is stepped down when entering the ready sewing status	Make sure the pedal is not stepped down when entering the ready sewing status
E-002	Pause	RESET key is pressed while sewing machine is running. The machine pauses.	Restart or return-to-origin after pressing RESET key for thread-trimming.
E-003	Head Tilt Error	Head tilt detection switch is set as ON.	The sewing machine cannot be operated with the head tilted. Return the sewing machine head to its proper position. Technicians can use short circuit board to short circuit the 2P blue plug on the headboard.
E-004	Low Voltage Error	The voltage of power is too low.	Sampling UZKIN analog quantity is too low. Confirm the voltage of power and related circuit.
E-005	Overvoltage Error	The voltage of power is over the specified value.	The detected signal of AC_OVDT is high. Confirm the voltage of power and related circuit.
E-007	Main shaft driver abnormal	The error is detected in main shaft driver.	Turn off the power and re-power the machine after a while.
E-008	24V power supply error	24V over-current	Turn off the power supply and then turn it on again after a while.
E-009	24V power supply error	24V voltage is too low	Turn off the power supply and then turn it on again after a while.
E-010	Air valve (fan) problem	After start, the system detects an abnormal signal about the voltage of the air	Shutdown the machine to check if there is any short circuit

Code	Name	Content	Solution
		valve or fan.	
E-012	Presser Foot Position Error	Presser foot is not at proper position.	Turn off the power and check connection of the CZ025 at the head signal circuit board. If the connection is ok, check the optocoupler.
E-013	Encoder Disconnection	The system can't detect ADTC signal.	Turn off the power, and confirm whether plug X5 is connected properly.
E-014	Motor Running Abnormal	When the main shaft motor is running, the range of the electrical angle is abnormal at 0°	Shutdown the machine to check the motor encoder.
E-015	Beyond Sewing Area	This sewing area is beyond the limit.	Press RESET switch to confirm the pattern and its X/Y scale rate. Triggering condition: pattern computation error.
E-016	Needle Bar Up Position Error	The needle bar is not at UP position.	The main shaft stop position error may be caused by main shaft drive, or may be caused by human error. Turn the hand wheel to return the needle bar to its UP position.
E-018	Cutter Position Error	The cutter is not at the right position.	Turn off the power and check the connection of the CZ024 at the head signal circuit board. If the connection is ok, check the optocoupler.
E-019	Emergency Stop Switch Not at Normal Position	Before start, the emergency stop switch is found pressed down	Manually solve the problem
E-020	Stepping Software Version Error	The software version for the stepping board is false.	Change the stepping board or update the stepping board program.
E-022	Machine Stop Due to Aging	After entering aging mode, the machine stops.	Shutdown the machine
E-023	Thread-catching Position Error	The thread-catching device is at wrong position.	Turn off the power and check the connection of the CZ026 at the head signal circuit board. If the connection is ok, check the optocoupler.
E-025	X Origin Search Error	X origin sensor doesn't change.	Turn off power and check the connections of CZ021 on head signal circuit board and X9 on control box.
E-026	Y Origin Search Error	Y origin sensor doesn't change.	Turn off power and check the connections of CZ022 on head signal circuit board and X9 on control box.

Code	Name	Content	Solution
E-027	Presser Origin Search Error	Presser origin sensor doesn't change.	Turn off power and check the connections of CZ025 on head signal circuit board and X9 on control box.
E-028	Thread-catching Origin Search Error	Thread-catching origin sensor doesn't change.	Turn off power and check the connections of CZ026 on head signal circuit board and X9 on control box.
E-030	Communication Error between Main-board and Stepping Board	Communication between Main-board and Stepping Board is down.	Turn off the power and re-power the machine after a while. Check the connections of the communication cable, main board and drive board.
E-031	Stepping driver Error	Over-current occurs to stepping drive board.	Turn off the power and re-power the machine after a while.
E-034	Main shaft driver abnormal	The error is detected in main shaft driver.	Turn off the power and re-power the machine after a while.
E-035	Main Board IPMSudden Over-current	The current for the main board IPM drive module is too much within a short period of time	Turn off the power and re-power the machine after a while. Change the main shaft motor to check if the motor is damaged; if problem remains, change the main board.
E-036	Main Board IPM Multiple Over-current	Over-current happens repeatedly to the main board IPM drive module after power on	Turn off the power and re-power the machine after a while. Change the main shaft motor to check if the motor is damaged; if problem remains, change the main board.
E-037	Main Shaft Over-current	Motor stops.	If there is no mechanic problem, check the connection of the main shaft encoder
E-038	Machine Lock Error	The main-shaft of sewing machine can't rotate due to some problem.	After user sending order to rotate the main shaft, the main shaft motor doesn't respond. Check the PWM curve of the main shaft motor, the signal of the encoder and whether there is mechanic problem.
E-039	Main Shaft Over-speed	The system detects the actual speed of the main shaft motor exceeding the speed limit	Turn off the power and re-power the machine after a while.
E-040	Current Abnormal When Stop	Over-current occurs during the stop process of the main shaft	Turn off the power and re-power the machine after a while. Change the main shaft motor to check if the motor is damaged; if problem remains, change the main board.
E-043	Thread-trimming Motor Origin Search Error	Thread-trimming origin sensor doesn't change.	Turn off power and check the connections of CZ026 on head signal circuit board and X9 on control box.

Code	Name	Content	Solution
E-044	Machine HeadBoard Parameter Abnormal with Lower Computer	The lower computer read abnormal parameter from the machine head board.	Check the machine head board and the connection of X9 cable. Press RESET key to use parameter No.67 to restore the parameters of the machine head board.
E-056	Stepping Close Loop DSP1(X25/X27) Communication Error	The verification of the received order at stepping board is failed	Check the connection of SPI communication cable
E-057	Stepping Close Loop DSP1 1 <sup>st</sup> Route(X27) Over-Current	Large current is detected by hardware	At first, please check motor. Then check the resistance and sensor value. If the motor is ok, user should check the hardware on stepping board
E-058	Stepping Close Loop DSP1 1 <sup>st</sup> Route (X27) Position Error	The detected encoder response position is not consistent with the position set in the order.	Change the stepping motor to open loop mode and run it. If the motor can work normally, the motor is ok. If the motor can't work normally, user should check the driving part on the stepping board and the motor itself. After the above operations, user should check the encoder. Make sure the connection and the condition of the encoder cable is ok. And make sure the signal response part on the stepping board and the encoder itself is ok.
E-059	Stepping Close Loop DSP1 1 <sup>st</sup> Route (X27) Over-speed	The system will give this warning when it detects the abnormal motor speed via the encoder response signal.	The checking method is the same with that for Position Error
E-060	Stepping Close Loop DSP1 2 <sup>nd</sup> Route (X25) Over-Current	Large current is detected by hardware	At first, please check motor. Then check the resistance and sensor value. If the motor is ok, user should check the hardware on stepping board

Code	Name	Content	Solution
E-061	Stepping CloseLoop DSP1 2 <sup>nd</sup> Route (X25) PositionError	The detected encoder response position is not consistentwiththeposition set in the order.	Change the stepping motor to open loop mode and run it. If the motor can work normally, the motor is ok. If the motor can't work normally, user should check the driving part on the stepping board and the motor itself. After the above operations, user should check the encoder. Make sure the connection and the conditionoftheencodercableisok.Andmake sure the signal response part on the stepping boardandtheencoderitselfisok.
E-062	Stepping CloseLoop DSP1 2 <sup>nd</sup> Route (X25)Over- speed	The system will give this warningwhenitdetectsthe abnormal motor speed via the encoder response signal.	Thecheckingmethodisthesamewiththatfor Position Error
E-063	Stepping Close Loop DSP2(X21/X 23) Communicati onError	The verification of the receivedorderatstepping board is failed	ChecktheconnectionofSPIcommunication cable
E-064	Stepping CloseLoop DSP1 1 <sup>st</sup> Route (X23) Over-Current	Largecurrentisdetected by hardware	At first, please check motor. Then check the resistanceandsensorvalue.Ifthemotorisok, user should check the hardware on stepping board
E-065	Stepping CloseLoop DSP2 1 <sup>st</sup> Route (X23) PositionError	The detected encoder response position is not consistentwiththeposition set in the order.	Change the stepping motor to open loop mode and run it. If the motor can work normally, the motor is ok. If the motor can't work normally, user should check the driving part on the stepping board and the motor itself. After the above operations, user should check the encoder. Make sure the connection and the conditionoftheencodercableisok.Andmake sure the signal response part on the stepping boardandtheencoderitselfisok.
E-066	Stepping CloseLoop DSP2 1 <sup>st</sup> Route(X23) Over- speed	The system will give this warningwhenitdetectsthe abnormal motor speed via the encoder response signal.	Thecheckingmethodisthesamewiththatfor Position Error
Code	Name	Content	Solution

E-067	Stepping CloseLoop DSP2 2 <sup>nd</sup> Route (X21)Over-cu rrent	Largecurrentisdetected by hardware	At first, please check motor. Then check the resistanceandsensorvalue.Ifthemotorisok, user should check the hardware on stepping board
E-068	Stepping CloseLoop DSP2 2 <sup>nd</sup> Route (X21) PositionError	The detected encoder response position is not consistentwiththeposition set in the order.	Change the stepping motor to open loop mode and run it. If the motor can work normally, the motor is ok. If the motor can' t work normally, user should check the driving part on the stepping board and the motor itself. After the above operations, user should check the encoder. Make sure the connection and the conditionoftheencodercableisok.Andmake sure the signal response part on the stepping boardandtheencoderitselfisok.
E-069	Stepping CloseLoop DSP2 2 <sup>nd</sup> Route (X21) Over-speed	The system will give this warningwhenitdetectsthe abnormal motor speed via the encoder response signal.	Thecheckingmethodisthesamewiththatfor Position Error
E-070	Stepping Board 90V PowerSupply Error	Steppingboard90Vis over-current	Turnoffthepowersupplyandthenturniton again after a while.

## OperationPanelErrorList

Code	Name	Content	Solution
M-300	Memory Abnormal	There exists error with the data defined by the operation panel.	Internal error: user need update the panel program.
M-301	Memory Abnormal	Panel memory data abnormal	Internal error: user need update the panel program.
M-302	Machine Type Parameter Error	The machine type data read by the operation panel is not within the set range.	Press RESET key to automatically enter parameter No.241 to select and save the defined machine type.
M-303	UK Parameter Abnormal	Abnormal range of the parameter read by the panel from EEPROM	Press RESET key to enter the system menu and recover the default setting.
M-304	Head Board Parameter Abnormal	Abnormal range of parameters received by panel from down computer	Press RESET key to enter the system menu and recover the default setting.
M-305	Normal Pattern Parameter Abnormal	When using pattern parameter, the panel detects abnormal parameter range.	Press RESET key to enter the system menu and recover the default setting.
M-306	Pattern Not Found or Locked	The prepared pattern No. hasn't been registered to ROM or set as not to be read. The pattern No. is displayed as 0.	Press RESET key, confirm the pattern No. and make sure the pattern is unlocked.
M-307	Pattern Data Abnormal	When the panel reads the sewing data of the pattern, the data format is found to be abnormal.	Select other patterns.
M-308	Sewing Data Too Large	When being computed, the size of the pattern data is found to be too large and beyond normal range.	Select other patterns for sewing.
M-309	Pattern beyond Sewing Range	When being computed, the pattern is found to be beyond sewing range.	Press RESET key, confirm the size of the pattern is within the set range of parameters K056, K057, K058 and K059.
M-310	Stitch Length beyond Normal Range	When being computed, the stitch length is found to be beyond normal range.	Press RESET key, confirm the pattern and X/Y scaling up rate.
M-311	Pattern Data Communication Abnormal	Error occurs when the panel sends pattern data to the main control.	Check the pattern and the cable connection between the panel and the main control.

Code	Name	Content	Solution
M-312	Normal PatternLock Abnormal	The panel can't read the normal pattern lock data from EEPROM.	Press RESET key to enter the system menu and recover the default setting.
M-313	Present Pattern Parameter Abnormal	The panel can't read the pattern parameter data from EEPROM.	Press RESET key to enter the system menu and recover the default setting.
M-314	Parameter Setting beyond Normal Range	The set value of the parameter exceeds normal range.	Press RESET key and change the set value.
M-315	Counter Abnormal	The panel can't read the counter data from EEPROM.	Press RESET key to enter the system menu and recover the default setting.
M-316	Counter Exhausted	The counter has reached the upper limit after the sewing.	Press RESET key.
M-317	Communication Error between Main Board and the Panel	There is no communication or communication error between main board and the panel.	Turn off the power and power the machine after a while. Check the communication cable, the main board and the panel.
M-318	The Storage Space for External Patterns Full	When patterns are imported to the control panel via USB, the storage space for such patterns is found full.	First export the internal patterns before deleting them, and then import patterns again.
M-319	External Patterns Format Abnormal	Pattern data is found abnormal when its format data is read by the control panel.	Enter the parameter import/export mode of the system and delete such patterns.
M-320	Imported Pattern Already Exist	When importing pattern from USB storage device, pattern with the same number is found to exist already in the panel.	Change the number of the pattern in the USB storage device to be imported.
M-321	Imported Pattern Not Found	When importing pattern from USB storage device, the pattern to be imported is not found.	Select existing patterns in the USB storage device.
M-322	Pattern Deletion Error	When deleting external pattern, it is found to not exist.	Select existing pattern for deletion.

Code	Name	Content	Solution
M-323	PatternRead Error	There is problem with reading pattern data from external pattern storage area.	Please select other patterns.
M-324	USB Device Not Connected	When importing or exporting patterns, the panel detects abnormal USB storage device.	Change another USB storage device
M-325	The Size of Imported Pattern Too Large	When importing patterns, the panel detects that the imported pattern is too beyond the size limitation.	Make sure the imported pattern is within the size range.
M-326	External Pattern Not Found	Under sewing ready status, the external pattern to be read is not found.	Please select other patterns.
M-327	P Pattern to Be Deleted is Cited by C Pattern	When being deleted, the P pattern is found to have been added to certain C pattern.	First delete the P pattern from the C pattern and then delete the P pattern.
M-328	USB Patterns Not Found	The pattern number to be imported can't be found after USB connection	Make sure the pattern is correctly named and saved under the designated directory of the USB storage device.
M-329	No Registered P Pattern	Before entering the P pattern or C pattern copy/deletion mode, no P pattern has been registered.	Please register P patterns before entering those modes.
M-330	All Normal Patterns Shut Down	Before entering P pattern registration mode, all normal patterns are found to have been shut down.	Please unlock normal patterns.
M-331	No More Registration of P Patterns	Before entering P pattern registration mode, it is found that all P patterns have been registered.	Please delete some P patterns before registering new ones.
M-332	No Deletion of the Last C Pattern	The C pattern to be deleted happens to be the last one.	The deletion of the remaining last C pattern is prohibited.
M-333	Alarm to Lubricate the Machine	It is time to add lubricating oil to certain parts of the machine, so the machine stops working.	Restart the machine, enter parameter No.245 and press RESET key, and then power on again
M-999	Undefined Error	Undefined error of the operation panel	Shutdown the machine and update the control panel program.

## 7 Appendix2

### InstallationSizeofOperationPanel



# InstallationSizeofControlBox

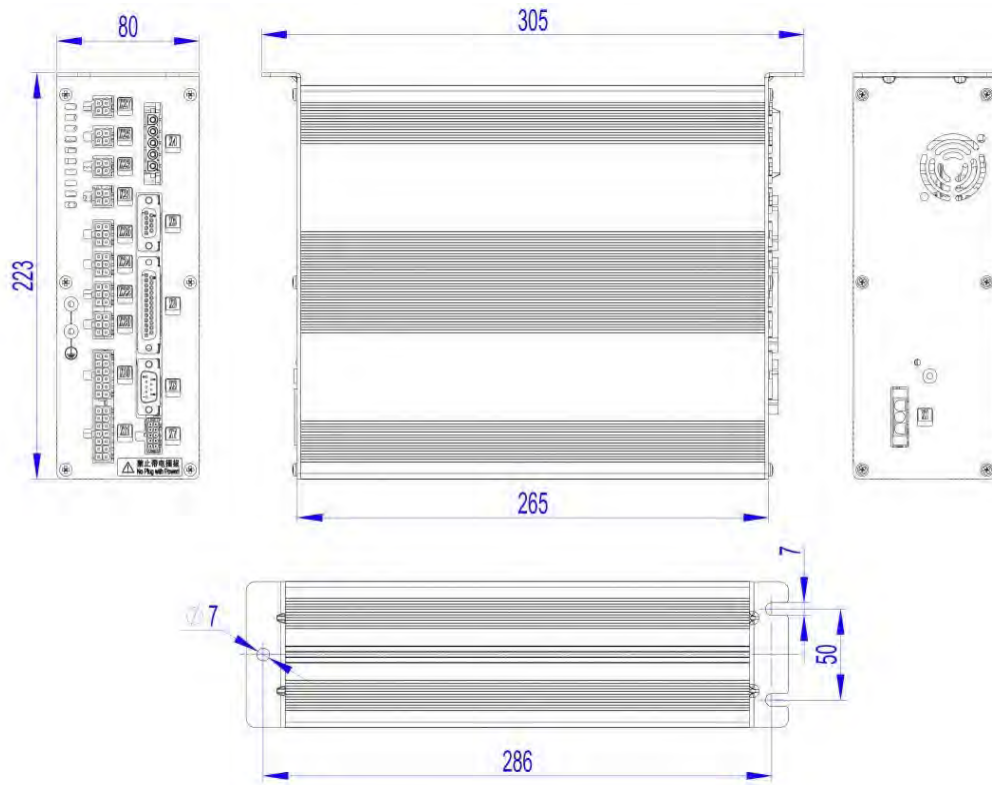

# SystemDiagram

## (1) MSC201-2K/ASystemDiagram

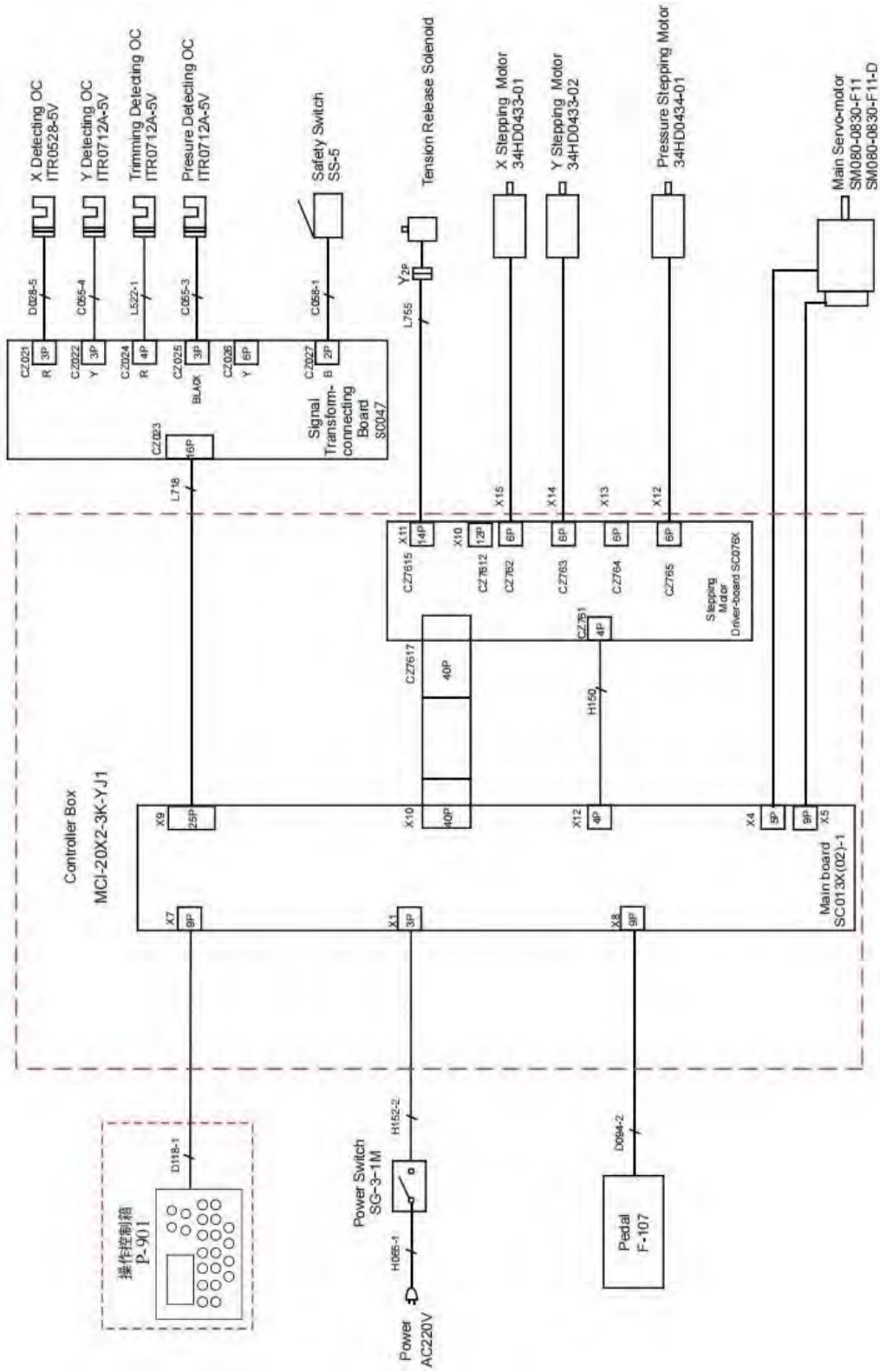







高林股份有限公司  
KAULIN MFG. CO., LTD.

由於對產品的改良及更新，本產品使用說明書中與零件圖之產品及外觀的修改恕不事先通知！  
The specification and/or appearances of the equipment described in this instruction book & parts list are subject to change because of modification which will without previous notice.  
CQL-23X02.FEB.2024