

# SIRUBA

使用說明書與零件圖

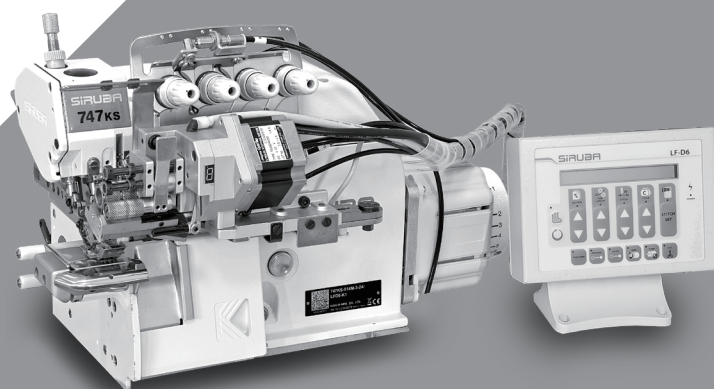

INSTRUCTION BOOK & PARTS LIST

■ 700KS-LFD6-K1







CE

## 危險水準的說明 Explanation of Dangerous Level

 <b>危險</b> Dangerous	<p>如果忽視此標記而運行了錯誤的機械操作，保養時肯定會引起當事者或第三者人員重傷或死亡。</p> <p>Don't ignore the warning sign and don't proceed incorrect operation. Or it will cause the person or the third party seriously injured or dead during maintenance.</p>
 <b>注意</b> Caution	<p>如果忽視此標記而運行了錯誤的機械操作，保養時有可能會引起當事者或第三者人員受傷及造成設備損壞。</p> <p>Ignoring this warning sign and proceed incorrect operation will cause the person involved or the third party wounded and equipment damaged during maintenance.</p>

## 警告圖案表示及表示標誌的說明 Explanation of Warning Signs and Labels

<b>警告圖案表示</b> Warning Sign		<b>運動部位，謹防工傷事故</b> Moving part, beware of industrial accident
		<b>高壓部位，謹防觸電事故</b> High voltage, beware of electric shock
		<b>高溫部位，謹防燙傷事故</b> High temperature, beware of burns
<b>指示標誌</b> Instruction Label		<b>禁止</b> Prohibited
		<b>地線的接線表示</b> Indication of ground wiring

索引	INDEX	頁 /PAGE
一般安全事項說明	GENERAL SAFETY INSTRUCTIONS	1
重要安全事項說明	IMPORTANT SAFETY INSTRUCTION	3
特別事項	WARNING	7
規格	SPECIFICATIONS	7
馬達及配件安裝配置	MOTOR CONTROL SYSTEM AND DEVICES INSTALLATION INSTRUCTION	8
提示代碼和錯誤代碼	TIP CODE LIST AND ERROR CODE LIST	9
組合圖	COMBINATION	11
接線圖	POWER WIRING DIAGRAM	12
接管圖	WIRING DIAGRAM	13
D6 裝置的調整	D6 DEVICE ADJUSTMENTS	14
控制盒面板說明	THE ILLUSTRATION OF THE CONTROL PANEL	17
參數說明	THE ILLUSTRATION OF THE PARAMETERS	19
使用說明	OPERATION GUIDE	22
故障排除	TROUBLESHOOTING	26
簡易維修	SIMPLE REPAIR	31
桌板圖	TABLE CUT-OUT	32
零件圖	PARTS LIST	33

## 一般安全事項說明

## GENERAL SAFETY INSTRUCTIONS

### 警告！

當使用這台機器，基本安全預防應恆被遵守，以減輕火災、電擊、或是個人傷害的風險。包含以下注意事項。  
在操作這台機器之前，請閱讀所有說明並且緊記於心。

- 1. 保持工作場所清潔**  
雜亂的環境與椅子會招引危害。
- 2. 考量工作場所環境**  
勿暴露電源於雨水之中、勿在溼氣重的地方或潮濕的場所使用機械器具。保持工作場所良好整齊。當有引發火災或爆炸危險時，勿使用電源工具。
- 3. 免於電擊危害**  
避免身體接觸地線或是接地表面。(即：管線，發熱物體，以及冷凍庫)
- 4. 勿使孩童接近**  
不要讓訪客接觸工具或是延伸管線。
- 5. 適當的穿著**  
不要穿著寬鬆衣物或是穿戴珠寶，這可能被活動零件拉扯而導致危險。穿戴護髮套可包住長髮。
- 6. 不要任意拉扯電線**  
絕不要用電源端拉扯機器，或是從插座猛拉電線來拔掉電線。使電線遠離熱源、油類或是尖銳邊緣。
- 7. 謹慎保養機器**  
遵從指示來添加潤滑油或是更換附件。定期檢測工具用線，如果有所損害，請使用合格的維修器具來修復。

### Warning!

When using this machine, basic safety Precautions should always be followed to reduce the risk of fire, electric shock and personal injury, including the followings. Read all these instructions before operating this product and save these instructions.

- 1. Keep work area clean**  
Cluttered areas and benches invite injuries.
- 2. Consider work area environment**  
Do not expose power to rain. Do not use machine tools in damp or wet locations. Keep work area well lit.  
Do not use power tools where there is risk to cause any fire or explosion.
- 3. Guard against electric shock**  
Avoid body contact with earthed or grounded surfaces (e.g. Pipes, radiators, ranges refrigerators.)
- 4. Keep children away**  
Do not let visitors touch the tool or extension code.
- 5. Dress properly**  
Do not wear loose clothing or jewelry, they can be caught in moving parts. Wear protecting hair covering to contain long hair.
- 6. Do not abuse the cord**  
Never carry the machine by cord or yank it to disconnect it from the socket. Keep the cord away from heat, oil, and sharp edges..
- 7. Maintain machine with care**  
Follow instructions for lubrication and changing accessories. Inspect tool cord periodically. If damaged, have it repaired by an authorized service facility.

## 8. 中斷機器電源

當不使用機器時、維修前、以及更換配件時。

## 9. 避免誤啟動

不要以手指置於啟動開關上之後，搬運一個已插入電源的工具。確定在插電之前，電源開關是關閉的。

## 10. 檢查損害零件

在進一步使用器具之前，應該小心檢查並確認損傷的零件或是穿戴保護器具來確認零件會正確運轉並且呈現應有功能。

## 11. 警告

除了在這本使用說明手冊中建議的功能之外，任何附件或是配件的使用，都可能會導致個人傷害的危險。

## 12. 由合格人員來修理工具

所以修理工作應由合格的人員使用原始個別零件來作修理。

### 連接電源的特別警示！

1. 只可與有 "CE" 認證的按壓啟動裝置連接這台機器。
2. 遵守此使用說明手冊來安裝控制裝置。
3. 在操作過程中，永遠保持機器適當的接地。
4. 在調整、更換零件、或是維修保養之前，必須確定將插頭由插座拔出，以預防任何機器意料之外的啟動而造成危害。

## 8. Disconnect machine

When not in use, before servicing and when changing accessories.

## 9. Avoid unintentional starting

Do not carry a plug-in tool with a finger on the switch. Ensure the power switch is off when plugging in.

## 10. Check damaged parts

Before further use of the tool, a guard or other part that is damaged should be carefully checked to determine that it will operate properly and perform its intended function.

## 11. Warning

The use of any accessory or attachment, other than those recommended in this instruction manual, may present a risk of personal injury.

## 12. Have your tool repaired by a qualified person







Repairs should only be carried out by qualified persons using original spare parts.

### SPECIAL WARNING FOR ELECTRIC CONNECTION!

1. Incorporate this machine only with "CE" certificate hold-to-run control device.
2. Follow the instruction manual device to install control device.
3. Always earth machine appropriately during operation.
4. Before adjustment, parts change or servicing must be sure to pull out the plug from socket to prevent the hazard of unintentionally start of machine.

## 重要安全事項說明



恭喜您購買本機器，為了使這台機器能獲得最佳功能以及安全的操作，務必請正確的使用這台機器，使用前請仔細閱讀使用說明書，希望您能長期使用它。請記得將此說明書放在容易取得的地方。

-  1. 當您使用機器時，除了以下事項外，請注意其他基本安全措施。
-  2. 使用機器前，除了本使用說明書外，請詳細閱讀其他相關說明書。此外，請妥善保存此說明書，以便需要時可以隨時取閱。
-  3. 先確認機器是符合貴國安全規定及標準後，再使用機器。
-  4. 當機器完成操作時，所有安全配備必須安裝就緒，在缺少所述安全配備下操作是不被允許的，以免導致人員受傷。
-  5. 此機器應由受過適當訓練之操作員操作。
-  6. 為了安全，我們建議您配戴安全眼鏡。
-  7. 以下情形，請先關閉電源或拔掉插頭：
  - (1) 穿針線、導線片、天平等以及更換梭子時。
  - (2) 更換針、壓具、針板、送具、頂針片、車布導板，以及其他附屬配件時。
  - (3) 維修工作時。
  - (4) 離開工作場所或工作場所無人看顧時。

## IMPORTANT SAFETY INSTRUCTION

For operating safely and getting the best functions of this machine, you must operate it correctly. Please read and follow the instructions of this manual, and keep it at hand for future references. We are confident that you will enjoy this machine as much as we enjoy manufacturing it.

-  1. Instead of the following instructions, when you use this machine, please pay attention to the basic safety measures.
-  2. Before using this machine, please read this manual and all related instructions. In addition, please keep this manual for future needs.
-  3. Before using this machine, please ascertain that it conforms with safety standards and regulations of your country.
-  4. When the machine is ready for operation, all the safety equipments must be ready. Operate this machine without the specified safety devices is not allowed.
-  5. This machine must be operated by a properly trained operator.
-  6. For your own safety, we suggest you wearing goggles.
-  7. Please turn off the power switch or disconnect it for any one of the circumstances of the followings:
  - (1) When threading needle(s), adjusting thread Take-up(s), thread guide(s), and/or replacing bobbin(s).
  - (2) When replacing needles, presser feet, needle plates, feed dogs, needle guards, cloth guides and other parts or accessories.
  - (3) When repairing.
  - (4) When the operator leaves the working place or leaves the machine unattended.

 8. 假如不慎讓機器及配件使用之油或油脂，接觸到眼睛、皮膚或誤食時，請立刻以水清洗接觸部位及就診。  



 9. 請勿擅自碰觸運轉中之零件及配件及注意機器電源是否已開啟，以免導致人員受傷。

 10. 維修、修改及調整等工作，須由受過適當訓練的技師或熟手為之。維修時只許使用指定之零件。

 11. 一般維修及檢查工作必須由受過適當訓練的人員為之。

 12. 電子零件維修及保養工作必須由資深的電子技師為之，或由非常熟練的人員檢查及指導，當發現零件損壞時，請立刻停止機器運轉。

 13. 在做裝有氣動式零件（例如氣缸）機器的維修及保養工作前，機器連接空壓機及高壓空氣必須予以關閉及卸除，機器中殘存高壓氣體必須予以消除，此外調整及性能檢查只能由受過適當訓練的技師或熟手為之。

 14. 機器使用一段時間，必須定期清理。

 8. If grease, oil, or any fluid contacts your skin or eyes by any chance, please wash the contacted area completely with clean water and consult a doctor. Or, swallow any fluid mistakenly, consult a doctor immediately.

 9. Do not touch any functioning parts and devices. Always attend to whether power switch is on or off before operating in order to prevent anyone from getting hurts.

 10. Qualified technicians are required for adjustment, modification, and repair. Only use assigned parts for replacement.

 11. Routine maintenance and service must be performed by well trained persons, or qualified technicians.

 12. Maintain and check the electronic parts must be done by qualified electrician or well-trained persons. If any electronic part damaged or malfunctioned, stop the machine immediately.

 13. The air house has to be detached from the machine and the compressor or air supply has to be cut off before repairing and servicing the machine equipped with pneumatic parts such as an air cylinder. Qualified technicians or well-trained persons are required for adjustment and repairs.

 14. To ensure the best performance, periodically clean the machine is necessary.

 15. 為使機器能正常操作以及減少噪音，機台務必平放地上，機器避免在強烈噪音的環境下操作。

 16. 選用適當的電源插頭，並由電子技師將其安裝在機器上，且插頭必須插在接地線之插座上。

 17. 機器只允許被使用於指定用途上，其他用途是不允許的。

 18. 修改或變更機器必須依照安全規定及標準，同時採取有效的安全措施或變更機器所引起損壞之責。

 19. 警告提示以兩種符號標示：

(1) 對操作員或服務人員之傷害危險，也為了避免觸電之危險，請勿打開馬達電器箱之外蓋，也不要觸摸電器箱裡面之零件。

 (2) 必須特別注意事項  
a. 絕對不可在移動外蓋，手指保護蓋或安全配件後，進行機器操作，以免導致人員受傷。

b. 為了避免被機器纏住，當機器運轉中，您的手、頭髮及衣服，需遠離手輪；此外這些部位周圍不可放置任何物品，以免導致人員受傷。

 15. In order to operate properly and to reduce the noise, please place the machine flat and level on the ground. Avoid operating the sewing machine at a noisy surrounding.

 16. Select a proper power plug and install it by an electrician. Please connect the power plug to a grounded receptacle.

 17. This machine can only be used for the designed purpose. Other uses of this machine are not allowed.

 18. Any modification or conversion made on this machine must be conformed with the safety standards and regulations. Precaution is necessary. No responsibility will our company take for damages caused by any modification or conversion of this machine without permission.

 19. Two safety warning signs are applied as warning signs:

(1) For the safety of operators and service persons, please don't open the cover of any electronic control boxes of motor or other devices and don't touch any components inside to avoid electrical shock hazards.

 (2) Always keep in mind:  
a. Please never operate this machine without outer cover, finger guard or any safety device to avoid physical injury.

b. Please keep your hair, fingers and clothes away from the hand wheel while the machine is in operation, as well as never put anything near these parts, to prevent the risk of injuries by tangled into them.



c. 當您打開電源開關後或機器已在運轉中，絕不可將您的手放在針的下方或針線控線桿外蓋中，以免導致人員受傷。



d. 當機器運轉中，梭頭高速轉動，為了避免對手可能引起之傷害，必須確定您的手保持遠離梭頭附近。此外，當更換梭子時，確定電源開關已關閉，以免導致人員受傷。



e. 當放置或抬起機器時，小心勿將手置於機器中，以免導致人員受傷。



f. 為了避免機器突然啟動而引起可能意外，當機頭傾斜時，請關掉機器電源，以免導致人員受傷。



g. 如果您的機器是配置伺服馬達，機器於靜止狀態時，馬達是不會產生噪音的，為了避免機器突然啟動而引起可能意外，故請關掉機器電源。



h. 為了避免觸電之危險，請絕不要在移開電源接地線後操作機器。



i. 為了避免觸電或電子零件損壞而引起之可能意外，請先切斷電源，再插上或拔掉插頭。



c. Please never put your fingers under the needle(s) or in the thread take-up cover to prevent physical injuries when you turn on the power switch or operate the machine.



d. While the machine is in operation, the hook rotates at a high speed. Please keep your hands away from the area of hook to prevent any potential injury to your hands. In addition, please make sure to turn off the power of the machine while changing bobbins.



e. Be careful and do not place your fingers inside the machine when placing or lifting the machine head to avoid possible physical injuries.



f. Please turn off the power before tilting the machine head to avoid possible accidents due to abrupt start of this machine.



g. For machine equipped servo motors, the motors do not produce noise while the machines are at rest. Therefore, please turn off the power of this accidents due to abrupt start of the machine.



h. Never operate the sewing machine after the ground wire is removed to avoid electrical shock hazards.



i. Please turn the power switch off before connecting or disconnecting the power plug to prevent possible accidents due to electric shock or damaged electronic components.

## 特別事項

為了避免機器故障及損壞，請先確定以下事項：

-  1. 當您安裝好機器後，做第一次機器操作前，請徹底清潔機器。
-  2. 清除運送途中累積之灰塵及溢出之油脂。
-  3. 確定電壓及馬達相數（單相或三相）安裝正確。
-  4. 確定電源插頭正確地接上電源。
-  5. 當使用電壓與標示電壓不同時，請勿使用機器。
-  6. 確定機器轉動方向是否正確。









**警告：**

在操作或調整本書中所提到之各步驟前，請先將電源關掉，以免因為機器突然啟動造成之意外。

## WARNING

Please confirm the followings to avoid malfunction or damage to this machine.

-  1. After installing the machine, and before the first operation, please clean it completely.
-  2. Clean all dust and overflowed oil during transportation.
-  3. Confirm that the voltage and the phase (single or 3 phase) of motor are set correctly.
-  4. Confirm that the power plug is correctly connected to the power supply.
-  5. Never use the machine when the local voltage type is different from the marked voltage on the nametag attached on the machine.
-  6. Confirm that the rotating direction of the machine pulley is correct.



**Warning:**

Before doing any operation or any adjustment described later in this manual, please turn the power off to prevent accidents caused by abrupt start of the sewing machine.

## 規格

## SPECIFICATIONS

數據的紀錄 Data record	2KBits
外型尺寸 External dimension	外觀 Appearance 長 Length 275 X 寬 Width 70 X 高 Height 250
電氣箱重量 Electrical box weight	4.9 公斤 / Kg
額定消耗電力 Rated power consumption	85W
使用溫度範圍 Temperature range	5°C ~ 55°C
使用濕度範圍 Humidity range	35% ~ 85% ( 無結露 / Non-condensing )
電源電壓 Power voltage	單相 Singlephase 220 VAC ±20% 50 / 60Hz

## 馬達及配件安裝配置

## MOTOR CONTROL SYSTEM AND DEVICES INSTALLATION INSTRUCTION

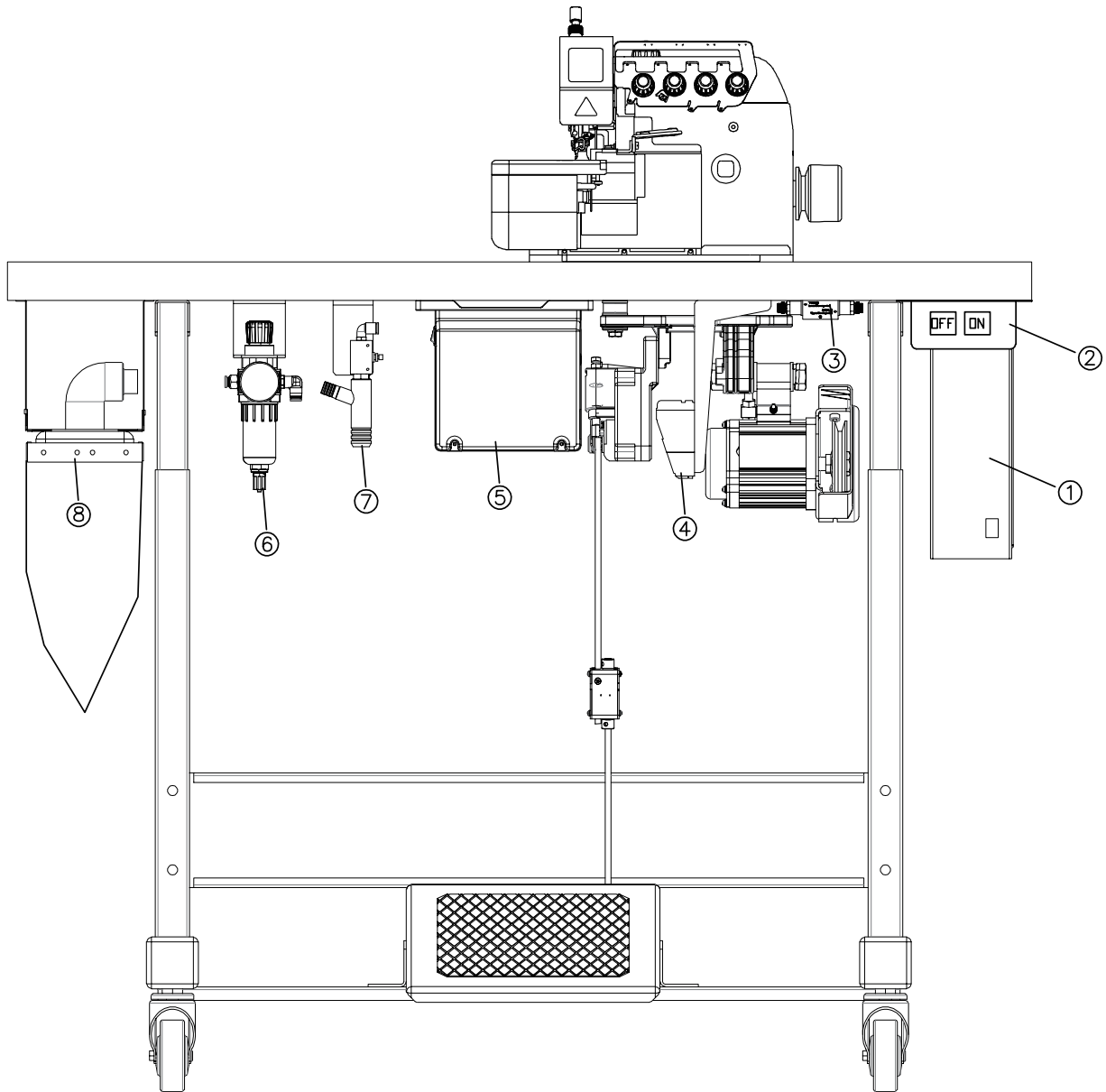

1. LF-D6 控制箱 (LF-D6 Control Box)
2. 開關 (Switch)
3. 上下吹控制閥 (Top & Under Blow Control Valve)
4. 膝動切帶開關 (Tape Cutting Switch)
5. 控制箱 (Control Box)
6. UT54K 氣壓錶 (UT54K Adjusting Filter)
7. 吸線頭調整閥 (Thread Suction Adjusting Valve)
8. 吸風集塵組 (Air Suction Dot Collectors)

## 提示代碼和錯誤代碼

## TIP CODE LIST AND ERROR CODE LIST

1. 單相電源線的接法：  
綠 / 黃色電線為接地線，一定要做好系統的  
接地工程，請洽合格的電氣工程人員予以施  
工。

1. Single phase connection:  
Green/yellow wire is the ground wire.

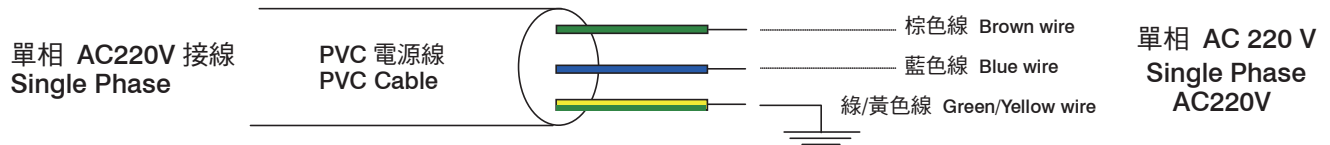

綠 / 黃色電線為接地線，一定  
要做好系統的接地工程。



Green / Yellow wire must do  
the grounding.

2. 當電源系統配置為三相四線式 380V 時，欲  
使用單相 220 V 供應本電機的接線方式。

2. How to connect a 1  $\Phi$  / 220 V power from a  
3  $\Phi$  / 380 V power source.



注意：  
如果此配置系統沒有【中性(點)  
線】時，則單相 220V 的伺服馬  
達不適合在此場所使用，請向  
原供應商改訂購本廠牌之三相  
380V 的伺服馬達機型。



Caution：  
If the power source does not  
have the neutral point, then this  
1  $\Phi$  / 220 V servo motor is not  
suitable for this connection.  
Please ask supplier to offer our  
3  $\Phi$  / 380 V servo motor.

注意：必須要有中性(點)線的配置

Caution: Must have a Neutral point

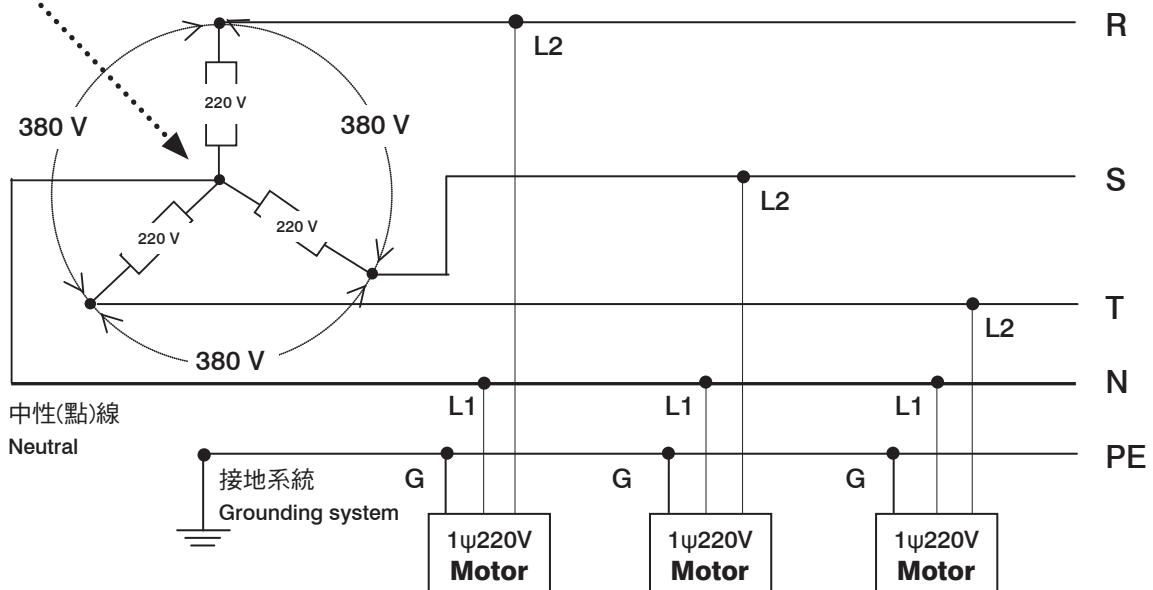

3. 當單相 220 V 伺服馬達欲使用在三相 220V 的電壓時，須注意配置使用上的負載平衡：連接相當多數量縫紉機配置使用時，需考慮三相中 R、S、T 各相的平衡，如下圖示：

3. The load balance when use a 1  $\Phi$  / 220 V motor used on a 3  $\Phi$  / 220 V power source. See the following figure for the load balance.

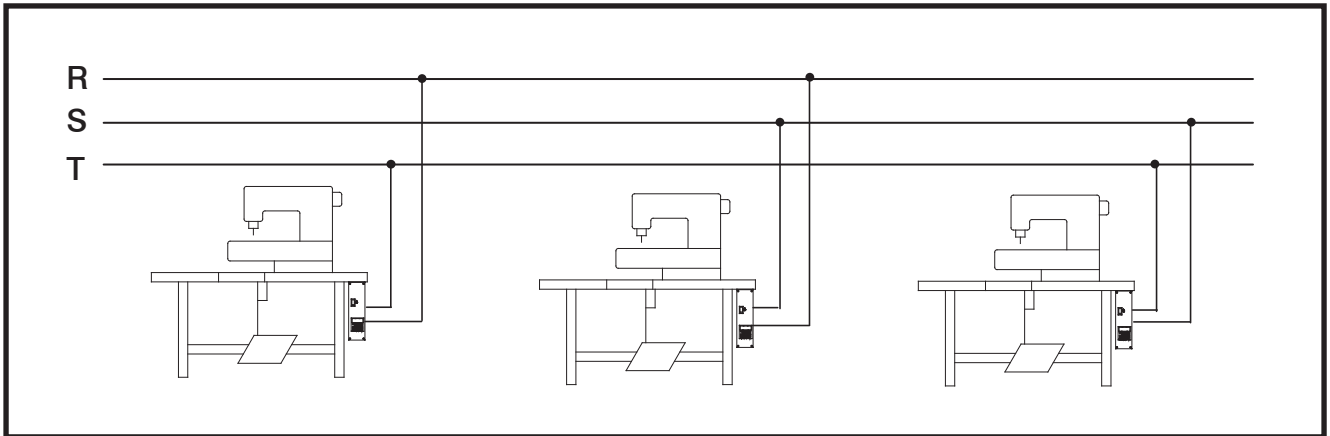

組合圖

COMBINATION

控制組 (1)  
Contrl Box(1)

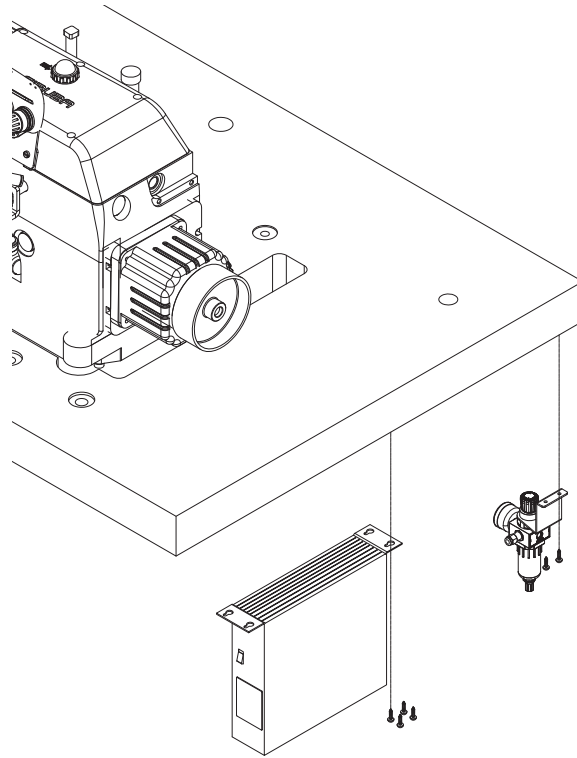

控制組 (3)  
Contrl Box(3)

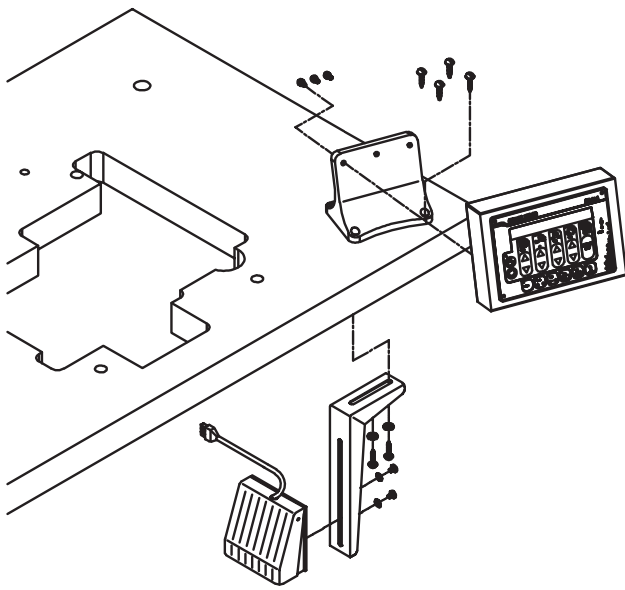

踏板開關  
Pedal Switch

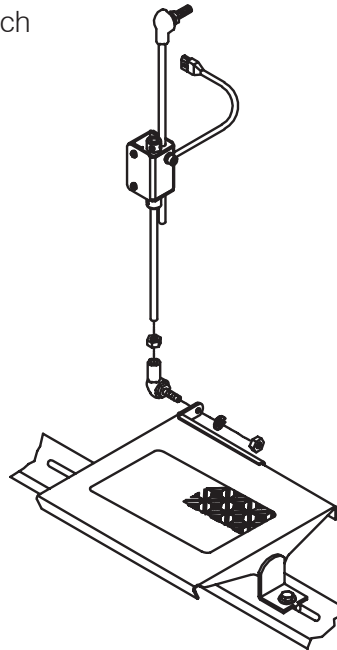

接線圖

POWER WIRING DIAGRAM

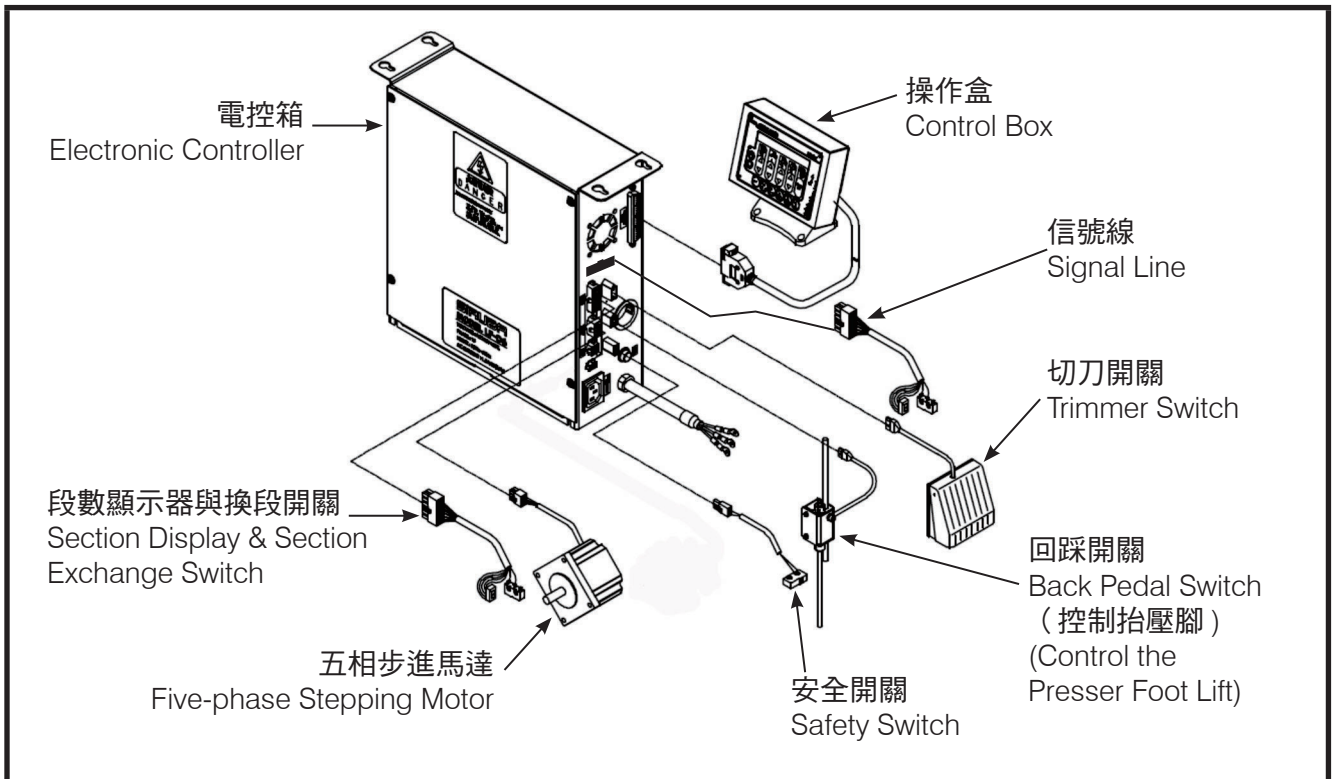

五連裝電磁閥：  
Five-even installed

- solenoid valve
- A. 控制壓腳動作  
Control the presser foot
- B. 控制切刀動作  
Control the trimmer
- C. 送帶吹風動作  
Sending the tape and blowing
- D. 鬆線功能  
The thread pull-off function
- E. 吸風集塵功能  
The suction function

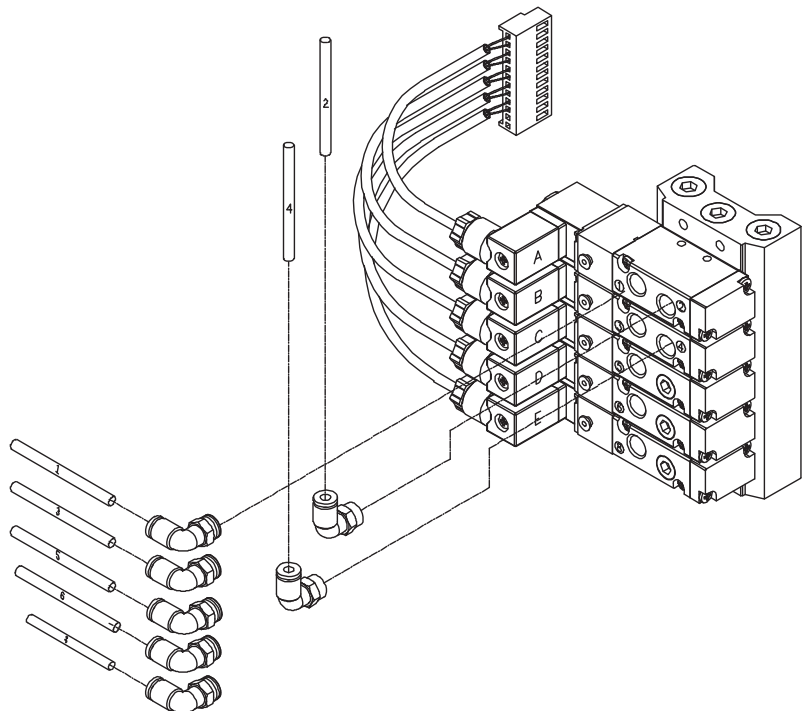

## 接管圖

## WIRING DIAGRAM

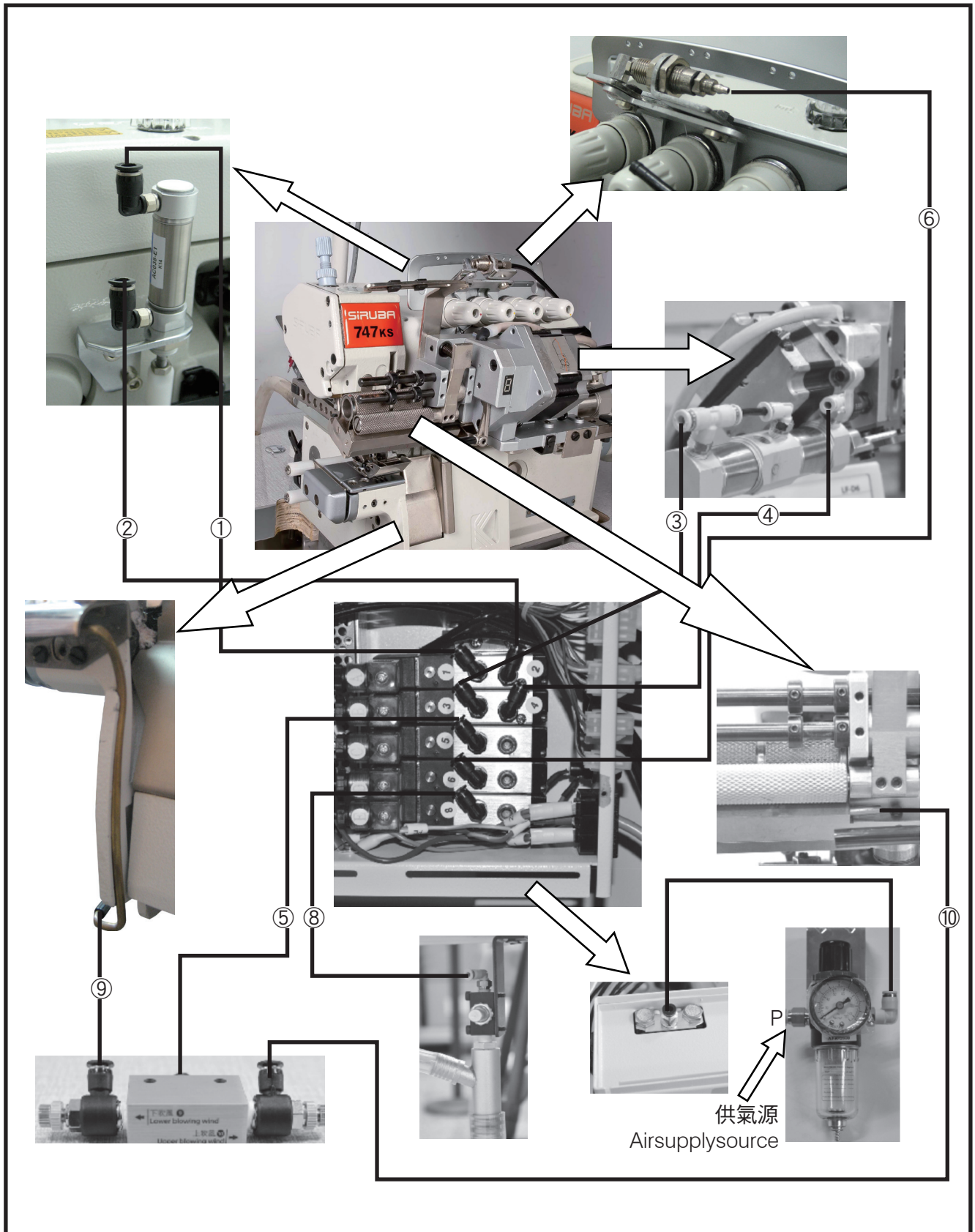

## D6 裝置的調整

### 警告

進行調整作業時，請關閉電源開關，請專業技術人員操作。

另外，進行作業時，注意避免裁料刀具割傷手指。

### 1. 高度調整

押具保持抬起狀態時，鬆動螺絲 SM532 可上下調整，使押具與 D6 裝置切刀面的間隙 1.0~2.0mm。

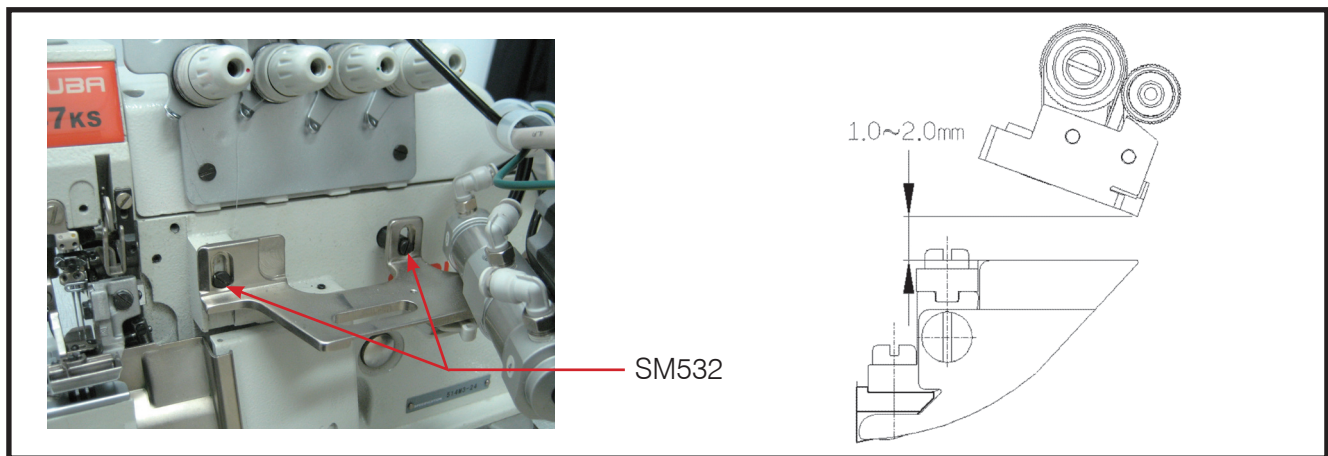

### 2. 調整送料滾軸的左右方向

- (1) 鬆動螺絲 SM441 和內六角螺絲 SM514。
- (2) 保持彈簧板 FD621 不移動，左右調整內六角螺絲 SM514 始送料滾軸與布料行進方向呈直角狀態。
- (3) 鎖緊內六角螺絲 SM514 和螺絲 SM441。

### 2. Adjust the left and right direction of the feed roller

- (1) loose screw SM441 and hexagon socket head cap screw SM514. (FIG.6)
- (2) keep spring plate FD621 fixed, adjust the hex socket head cap screw SM514 in left or right direction to make feed roller and fabric forward motion as right angles.
- (3) fasten hexagon socket head cap screw SM514 and screw SM441.

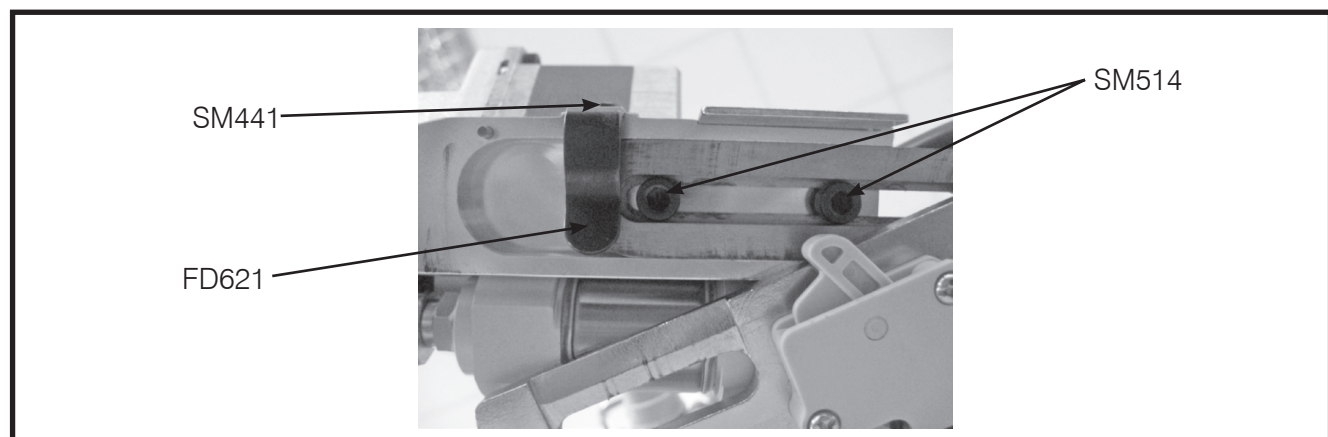

### 3. 調節裁料刀具的咬合度及間隙

鬆開螺帽，旋轉氣缸心軸，向 A 方向旋轉，運動刀具 FD112C 和固定刀具 FD616 的咬合度變大，向 B 方向旋轉，則咬合度變小。

請將咬合度調節至 1.0 ~ 2.0mm。(工廠出貨狀態下的咬合度)

根據縫制條件要求，旋轉螺絲 SK462 調節運動刀具和固定刀具的咬合間隙。(建議薄料時將間隙調大，厚料時將間隙調小)

### 3. The occlusion and the gap of adjusting the cutter tool.

Loose the nut and turn the air cylinder shaft. Turn toward the direction A. The occlusion degree of the movable knife FD112C and the fixed knife FD616 would be larger. Turn toward the direction B, the occlusion degree would be smaller.

Please adjust the occlusion to 1.0~2.0mm. (The occlusion when manufactured.)

According to the sewing requirements, turn the screw SK462 to adjust the occlusion gap of the movable knife and the fixed knife. (Suggest enlarging the gap when sewing the light material; narrow the gap when sewing the heavy material.)

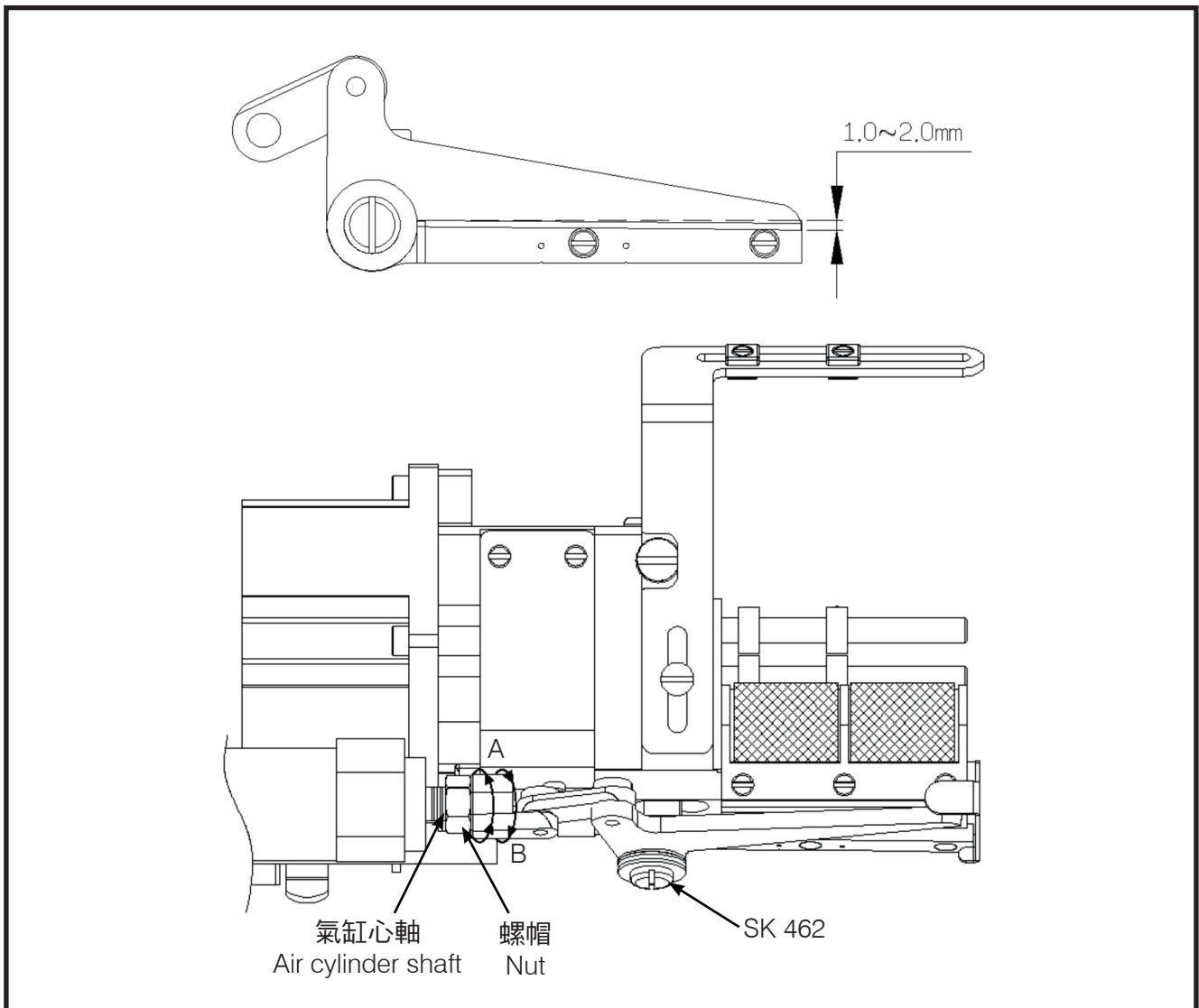

## 4. 吹氣孔位置調整

調整送帶滾輪的左右方向 (方法見前述及圖六), 使紅線對準鬆緊帶中央 (送帶用吹氣孔在紅線的下方) (如圖 A)。須注意, 長輪有兩條紅線, 使用 1 英寸以下鬆緊帶時, 使右邊紅線對準鬆緊帶中央 (如圖 B); 使用 1 英寸以上鬆緊帶時, 使左邊紅線對準鬆緊帶中央即可。(如圖 C)

## 4. Adjust the position of blowing hole.

Adjust the feeding roller for aligning the red line to the center of the elastic belt. (The blowing hole of the feeding tape is under the red line.) (As the diagram A) Be aware that there are two red lines. For using the elastic belt less than 1 inch, have it align to the right red line (As the diagram B); for using the elastic belt over 1 inch, have it align to the left red line. (As the diagram C)

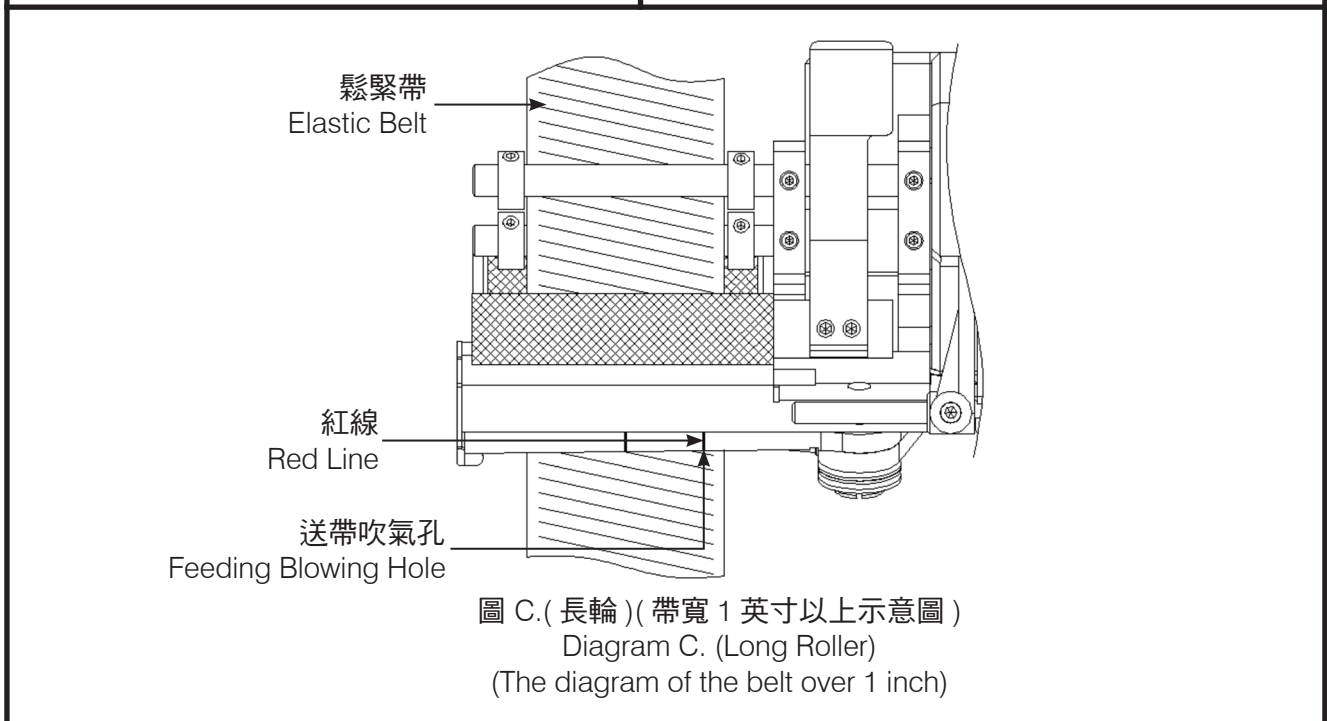
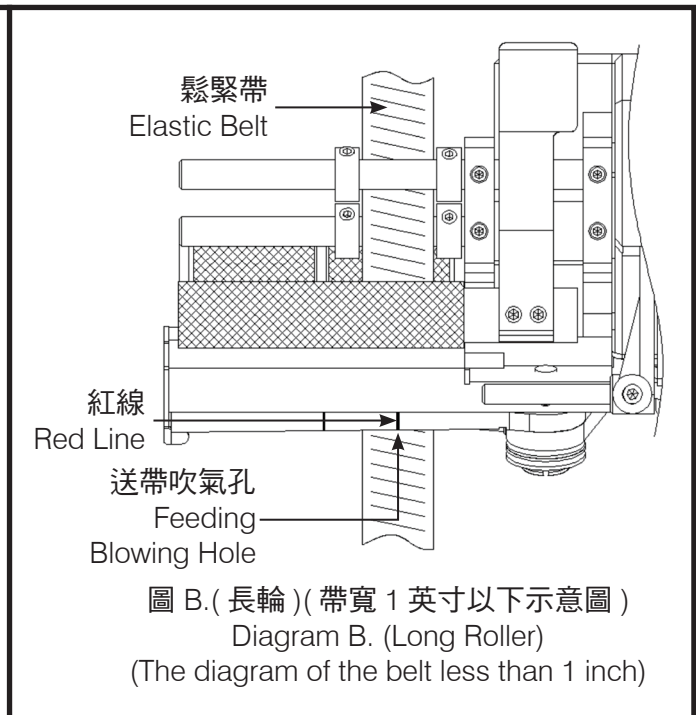
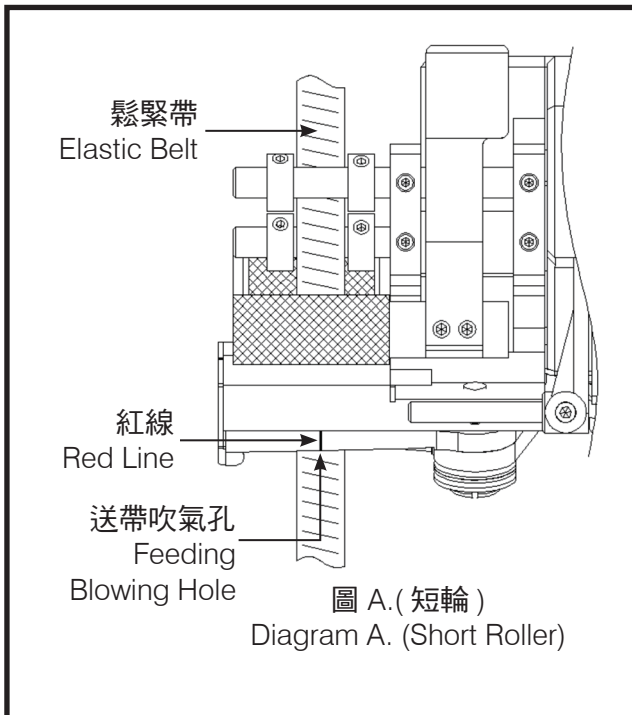

## 控制盒面板說明

## THE ILLUSTRATION OF THE CONTROL PANEL

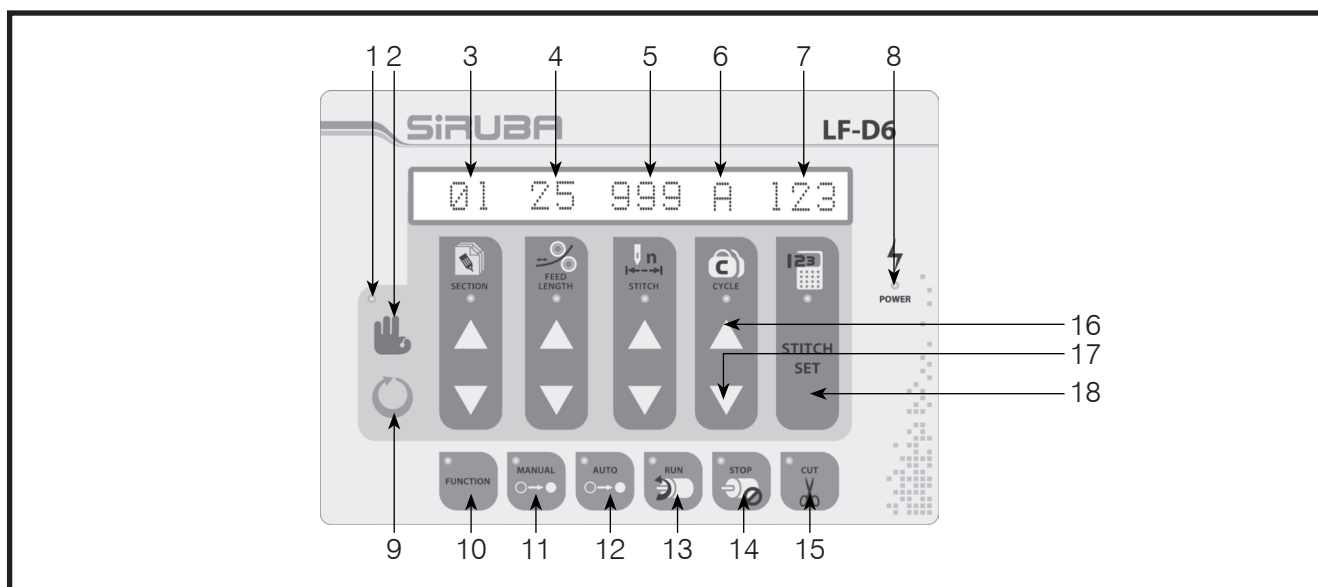

1. 車縫模式指示燈：指示燈 ON 表示車縫模式；指示燈 OFF 表示設定模式。

2. 準備鍵：可用於轉換車縫模式或設定模式。

3. 工程段數：可設定 1~18 工程段數。

4. 送料長度：設定每針送料長度，設定 5~65。  
(5 表示 0.5mm；65 表示 6.5mm)

5. 針數設定：設定每一段工程的所需的針數，設定值 0~999 針。

6. 循環設定：可儲存 10 組循環縫製設定 (A~J)。

7. 針數計數：計數已車縫完成的針數值。

8. 電源指示燈：顯示綠色指示燈表示可正常車縫；顯示橘色燈表示有故障需排除；指示燈 OFF 時，請確認電源開關是否開啟。

9. 取消鍵：可設定循環結束；可取消循環結束；可載入原設定值。

1. Sewing mode indicator light: When the indicator light is ON, it indicates the sewing mode; when the indicator light is OFF, it indicates the setting mode.

2. Preparation key: It is used to switch between the sewing mode and the setting mode.

3. Section: Set sections 1~18.

4. Feeding length: Set the feeding length for each stitch. The setting values are 5~65. (5 indicates 0.5mm; 65 indicates 6.5mm)

5. Stitch setting: Set the number of stitches that is required for each section. The setting values are 0~999 stitches.

6. Circulation setting: It can memorize 10 sets of setting values of circulatory Sewing (A~J).

7. Stitch count: It counts the number of stitches that is completed.

8. Power light: When the light is green, it indicates the normal sewing. When the light is orange, it indicates that there is a glitch which has to be eliminated. When the light is OFF, check if the switch is turned on.

9. Cancel key: It can end the circulation setting; it can end the circulation cancelling; it can load the original setting value.

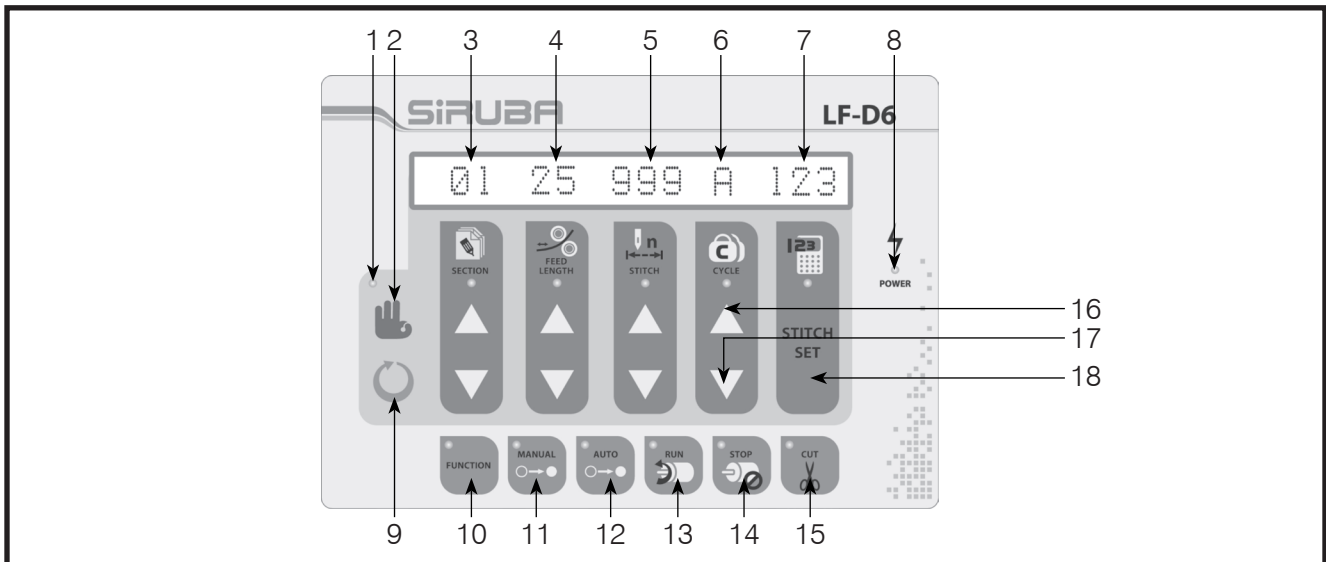

10. 功能鍵：按此按鍵可進入系統參數設定功能。
11. 手動鍵：用手動方式觸動開關，以進入下一段車縫工程
12. 自動鍵：當車縫針數計數到達設定值時，系統自動進入下一段車縫工程。
13. 馬達轉動鍵：按此按鍵時馬達會轉動，可用於送入或退出鬆緊帶。  
P.S.: 參數 9 設定值為 0：馬達轉動時，可退出鬆緊帶。參數 9 設定值為 1：馬達轉動時，可送入鬆緊帶。
14. 馬達停止鍵：按此按鍵系統會進入馬達停止轉動模式。  
P.S.: 在馬達停止轉動模式，按功能鍵可進入測量縫紉機轉速功能。
15. 切刀鍵：按此鍵可在車縫段數間，執行或取消切刀動作。
16. 增加鍵：增加設定數值。
17. 減少鍵：減少設定數值。
18. 載入針數鍵：可在車縫設定模式，將計數器所顯示的車縫針數，載入到該車縫段的針數設定值，原有的針數設定值將會被刪除。

10. Function key: Press this key to enter the parameter setting function.
11. Manual key: Turn on the switch manually to enter the next section.
12. Automation key: When the number of stitches is completed, the system enters the next section automatically.
13. Motor operating key: Press this key to start the motor, and the elastic tape can be fed or withdrawn.  
P.S.: parameter 9, setting value 0: When the motor operates, the elastic tape is withdrawn.  
parameter 9, setting value 1: When the motor operates, the elastic tape is fed.
14. Motor stopping key: Press this key to Stop the motor.  
P.S.: When the motor stops operating, press this key to enter the function of measuring the rotational speed of the sewing machine.
15. Trimmer key: Press this key to execute or cancel the thread cutting during the sections.
16. Increase key: Increase the setting value.
17. Decrease key: Decrease the setting value.
18. Stitch loading key: In the sewing setting mode, the number of stitches shown on the counter can be loaded to the stitch setting value of the section, and the original stitch setting Value is cancelled.

## 參數說明

## THE ILLUSTRATION OF THE PARAMETERS

- 視窗顯示 /The panel shows : **1 INS L 50**  
送帶長度設定，設定值 0 ~ 200。  
0：表示送帶 0mm；  
200：表示送帶 200mm。
- 視窗顯示 /The panel shows : **2 INS Sp 50**  
步進馬達送帶速度設定，設定值 1 ~ 99。  
1：表示送帶速度最慢；  
99：表示送帶速度最快。
- 視窗顯示 /The panel shows : **3 Back L 15**  
起縫時鬆緊帶拉回長度設定，設定值 0 ~ 60。  
0：表示拉回 0mm；  
60：表示拉回 60mm。
- 視窗顯示 /The panel shows : **4 CUT Ti 150**  
切刀動作延遲時間，設定值 0 ~ 800。  
0：表示延遲 0 mS；  
800：表示延遲 800 mS。
- 視窗顯示 /The panel shows : **5 CUT St 10**  
切刀動作完成後，車縫剩餘鬆緊帶所需的針數。設定值 0 ~ 99。  
0：表示所需針數 0 針；  
99：表示所需針數 99 針。  
P.S. :  
1. 參數 12 設定值為 1 時，所需針數車縫完成後，會自動啟動鬆線與吸風集塵功能。  
2. 參數 12 設定值為 0 時，所需針數車縫完成後，只會自動啟動吸風集塵功能。
- 視窗顯示 /The panel shows : **6 Foot Up 0**  
縫製功能完成後，壓腳是否自動提升。設定值 0 ~ 1。  
0：表示關閉此功能；  
1：表示開啟此功能。
- 視窗顯示 /The panel shows : **7 OFF St 10**  
車縫開始時自動啟動吸風集塵功能，可設定幾針後關閉。設定值 0 ~ 99。
- Set the length of the tape which is fed. The setting values are 0~200.  
0 indicates the length is 0mm;  
200 indicates the length is 200mm.
- Set the speed at which the step motor feeds the tape. The setting values are 1~99.  
1 indicates the speed is the lowest;  
99 indicates the speed is the highest.
- Set the length of the tape which is pulled back at the start of sewing. The setting values are 0~60.  
0 indicates the length is 0mm;  
60 indicates the length is 60mm.
- Set the time for which the trimmer delays cutting the thread. The setting values are 0~800.  
0 indicates the time is 0 ms;  
800 indicates the time is 800 ms.
- The accomplishment of the trimmer, the needle numbers which need to sewing the rest elastic belt. The setting value is 0 ~ 99.  
0: It indicates that the needful needle numbers is 0.  
99: It indicates that the needful needle numbers is 99.  
P.S.:  
1. If the setting value of the parameter 12 is 1, after the accomplishment of the sewing, it performs the function of loosening wires and the suction automatically.  
2. If the setting value of the parameter 12 is 0, after the accomplishment of the sewing, it only performs the function of the suction automatically.
- Set whether the presser foot is raised automatically after the function of sewing is completed. The setting values are 0~1.  
0 indicates the function is off;  
1 indicates the function is on.
- Set the number of stitches after which the function of gathering the lint through suction starting at the beginning of sewing ends. The setting values are 0~99.  
0 indicates the number of stitches is 0;  
99 indicates the number of stitches is 99.

- 視窗顯示 /The panel shows : **8 ET-H Ti 5**  
車縫結束，壓腳停止踩踏後，可設定延遲關閉吸風集塵的時間。設定值 0 ~ 30。  
0：表示延遲 0 秒關閉；  
30：表示延遲 3.0 秒關閉。

- 視窗顯示 /The panel shows : **9 CCW-CW 1**  
按馬達轉動鍵時，步進馬達轉動方向。設定值 0 ~ 1。  
0：表示步進馬達退帶；  
1：表示步進馬達送帶。

- 視窗顯示 /The panel shows : **10 AIR - 1**  
切刀動作後，回踩踏板會執行送帶動作。送帶完成後，回踩踏板是否執行上 / 下吹風動作。設定值 0 ~ 1。  
0：表示送帶後，回踩踏板不執行上 / 下吹風  
1：表示送帶後，回踩踏板執行上 / 下吹風

- 視窗顯示 /The panel shows : **11 CUT CT 15**  
設定切刀閉合的時間。設定值 5 ~ 50。  
5：表示切刀閉合時間為 50ms；  
50：表示切刀閉合時間為 500ms。

- 視窗顯示 /The panel shows : **12 TR ACT 1**  
設定車縫結束是否啟動鬆線功能。設定值 0~1。  
0：表示車縫結束不啟動鬆線功能；  
1：表示車縫結束啟動鬆線功能。

- 視窗顯示 /The panel shows : **13 INS DT 25**  
設定延遲啟動送帶功能的時間。設定值 5 ~ 80。  
5：表示當車縫結束後偵測到回踩踏板動作時，延遲 50ms 才啟動送帶功能。  
80：表示當車縫結束後偵測到回踩踏板動作時，延遲 800ms 才啟動送帶功能。

PS：當車頭伺服馬達設定車縫停止針棒停在下停針位置，此時回踩踏板，伺服馬達會運轉到上停針位置的設定狀態，為避免伺服馬達運轉帶動檢知器而被系統誤判，並中斷送帶動作造成送帶長度不準確，建議此參數調整成 25 以上。

- Set the time for which the function of gathering the lint through suction delays ending after the sewing is completed and the pedal is not stepped on. The setting values are 0~30.  
0 indicates the time is 0 second;  
30 indicates the time is 3.0 seconds.
  - Set the rotation direction of the step motor after the motor operating key is pressed. The setting values are 0~1.  
0 indicates that the step motor withdraws the tape;  
1 indicates that the step motor feeds the tape.
  - After the trimmer is done with its task, the back pedal will feed the tape. After feeding the tape, should the back pedal execute the top / bottom blow device. The setting value 0 & 1:  
0: It indicates that after feeding tape, the back pedal would not execute the top / bottom blow device.  
1: It indicates that after feeding tape, the back pedal would execute the top / bottom blow device.
  - Set the timing of the trimmer closure. The setting value is 5 ~ 50.  
5: It indicates that the timing of the trimmer closure is 50ms;  
50: It indicates that the timing of the trimmer closure is 500ms.
  - Set to check if the function of loosening wire is turned on after the accomplishment of sewing. The setting value is 0 ~ 1.  
0: It indicates that the function is not turned on after the sewing.  
1: It indicates that the function is turned on after the sewing.
  - Set the time of delaying the feeding function start. The setting value is 5~80.  
5: indicates When the completion of sewing and the backward tread action is detected, the feeding function will start after delaying 50ms.  
80: indicates When the completion of sewing and the backward tread action is detected, the feeding function will start after delaying 800ms.
- PS: When the machine servo motor is set to drop the needle at the position of bottom stop needle as the sewing stops, tread the pedal at the moment, and the servo motor will rotate to let the needle drop at the setting state of top stop needle position. In order to avoid the system error because the servo motor's

rotation drives the detector as well as stops the feeding and causes the incorrect feeding length. It is suggested to set the parameter over 25.

- 視窗顯示 /The panel shows : **14 GAT ST 0**  
設定吸風集塵功能。設定值 0 ~ 3。  
0：表示每一個循環縫，只有第一段會執行吸風集塵動作。  
1：表示每一個循環縫，每一段都會執行吸風集塵動作。  
2：表示每一個循環縫，每一段都會固定針數執行吸風集塵動作。  
3：表示只要馬達轉動都會執行吸風集塵動作。  
P.S：執行吸風動作的固定針數由參數 7 設定。

- 視窗顯示 /The panel shows : **15 Back S 0**  
設定起縫鬆緊帶開始執行回拉的針數。設定值 0 ~ 99。  
0：表示起縫立即執行鬆緊帶回拉長度設定。  
99：表示起縫 99 針後才執行鬆緊帶回拉長度設定。

- 在參數設定功能中，長按功能鍵，即可進入參數 A 修改設定畫面。
- 視窗顯示 /The panel shows:  
參數 A：送帶補償功能設定。設定值 0 ~ 9 當車縫速度快慢造成送帶長度有誤差時，可以調整參數 A 進行補償。

- Set the suction function. The setting values are 0~3.  
0：indicates that the suction is performed at the first section for each circulatory sewing.  
1：indicates that the suction is performed at every section for each circulatory sewing.  
2：indicates that the suction is performed with designated number of stitches at every section for each circulatory sewing.  
3：indicates that the suction is performed as long as motor rotates.  
P.S.Set the number of stitches through parameter 7.
- Set the number of stitches for pulling back the tape after sewing starts. The setting values are 0 ~99.  
0：indicates that the tape is pulled back immediately after sewing starts.  
99：indicates that the tape is pulled back after the 99th stitches of sewing is performed.
- In the parameter setting function, enter the setting adjustment of parameter A by keeping pressing the function key.
- Parameter A: Set the feeding tape compensation. When the tape feeding is uneven caused by different sewing speed, it can be compensated by adjusting parameter A.

Setting Value \ Speed(RPM)	3000	4000	5000	6000
0	0%	0%	0%	0%(Note1)
1	0%	0%	0%	0%(Note2)
2	0%	0%	1%	1%
3	0%	1%	1%	1%
* 4	0%	1%	1%	2%
5	0%	1%	2%	2%
6	1%	2%	3%	4%
7	1%	3%	5%	7%(Note3)
8	1%	4%	7%	10%
9	1%	4%	8%	11%

Note1: “0%” 表示送帶長度無補償  
Note2: “1%” 表示送帶長度增加 1%  
Note3: “7%” 表示送帶長度增加 7%

Note1: “0%” represents no compensation to the length of the feeding tape.  
Note2: “1%” represents compensation 1% to the length of the feeding tape.  
Note3: “7%” represents compensation 7% to the length of the feeding tape.

## 使用說明

## OPERATION GUIDE

1. 設定模式與車縫模式切換：

1. The switch between the setting mode  
And the sewing mode:

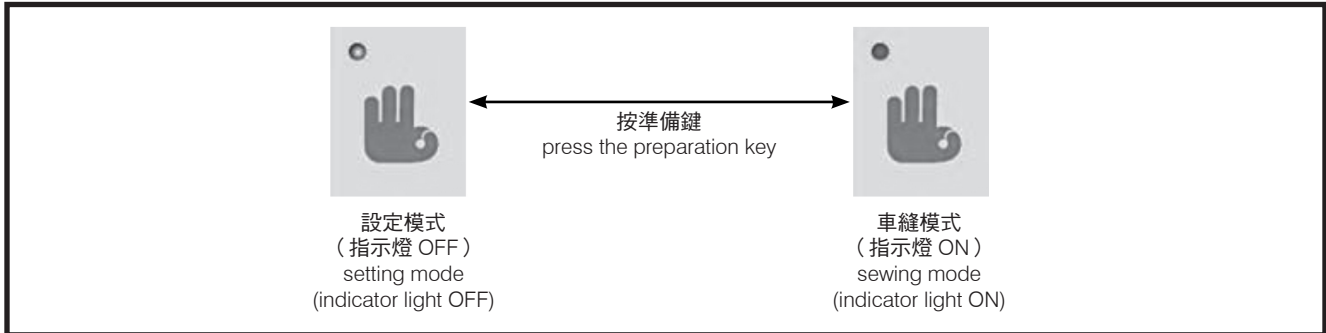

2. 設定段數結束或取消段數結束：

2. End the section setting or end the  
Section canceling:

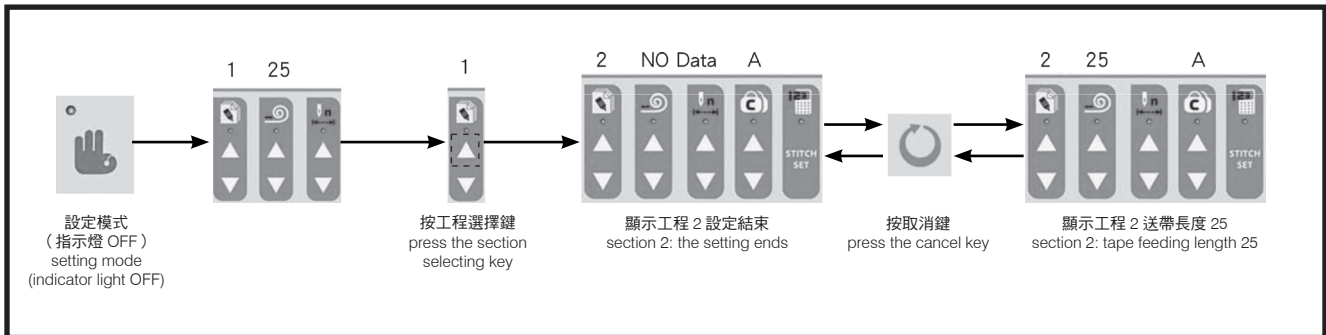

3. 單一個段數設定 (手動換段)：

3. Set the single section (manual switch):

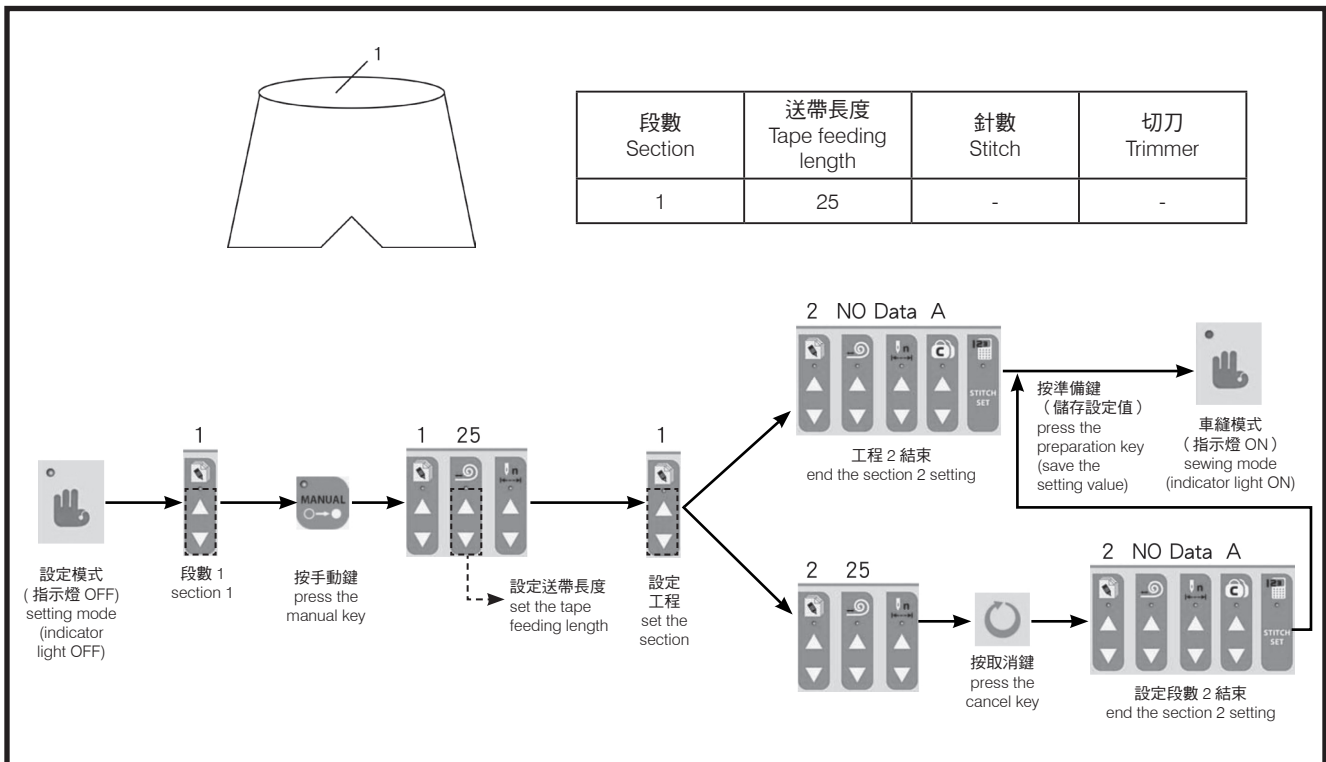

## 4. 單一個段數設定 (自動換段)

## 4. Set the single section (automatic switch)

段數 Section	送帶長度 Tape feeding length	針數 Stitch	切刀 Trimmer
1	25	100	-

設定模式 (指示燈 OFF) setting mode (indicator light OFF) → 工程 2 section 2 → 按自動鍵 press the automation key → 設定送帶長度 set the tape feeding length → 設定針數 set the number of stitches → 設定工程 set the section → 工程 2 結束 end the section 2 setting → 按準備鍵 (儲存設定值) press the preparation key (save the setting value) → 車縫模式 (指示燈 ON) sewing mode (indicator light ON) OR 按取消鍵 press the cancel key → 設定段數 2 結束 end the section 2 setting

P.S.: 車縫到設定針數時，會自動執行切刀動作，並自動將車縫針數歸零。

P.S: When the number of stitches is completed, the trimmer automatically cut the thread, and the number of Stitches automatically returns to zero.

## 5. 第一、二段設定自動換段；第三段設定手動換段

## 5. Automatically switch to the first and the second sections; manually switch to the Third section

段數 Section	送帶長度 Tape feeding length	針數 Stitch	切刀 Trimmer
1	25	100	-
2	35	100	-
3	40	-	-

設定模式 (指示燈 OFF) setting mode (indicator light OFF) → 工程 1 section 1 → 按自動鍵 press the automation key → 設定送帶長度 set the tape feeding length → 設定針數 set the number of stitches → 工程 2 section 2 → 按自動鍵 press the automation key → 設定送帶長度 set the tape feeding length → 設定針數 set the number of stitches → 工程 3 section 3 → 按手動鍵 press the manual key → 設定送帶長度 set the tape feeding length → 設定 4 section 4 → 工程 4 結束 end the section 4 setting → 按準備鍵 (儲存設定值) press the preparation key (save the setting value) → 車縫模式 (指示燈 ON) sewing mode (indicator light ON) OR 按取消鍵 press the cancel key → 設定段數 4 結束 end the section 4 setting

6. a. 一件衣物有兩處需縫製鬆緊帶，這兩處鬆緊帶均有兩個段數設定。
- b. 第一處鬆緊帶車縫採用自動切刀方式，第二處鬆緊帶車縫採用用手動切刀方式；  
（段數 1、2、3：自動換段車縫模式；段數 4：手動換段車縫模式）。

6. a. The elastic tapes have to be sewed on the two parts of the clothing, and There are two kinds of section settings for both parts.
- b. The automatic trimming is adopted for the first elastic part, and the manual trimming is adopted for the second elastic part. (section 1, 2, 3: automatic section switch; section 4: Manual section switch)

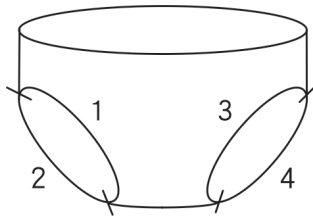

段數 Section	送帶長度 Tape feeding length	針數 Stitch	切刀 Trimmer
1	25	120	-
2	20	100	Auto
3	25	120	-
4	20	-	-

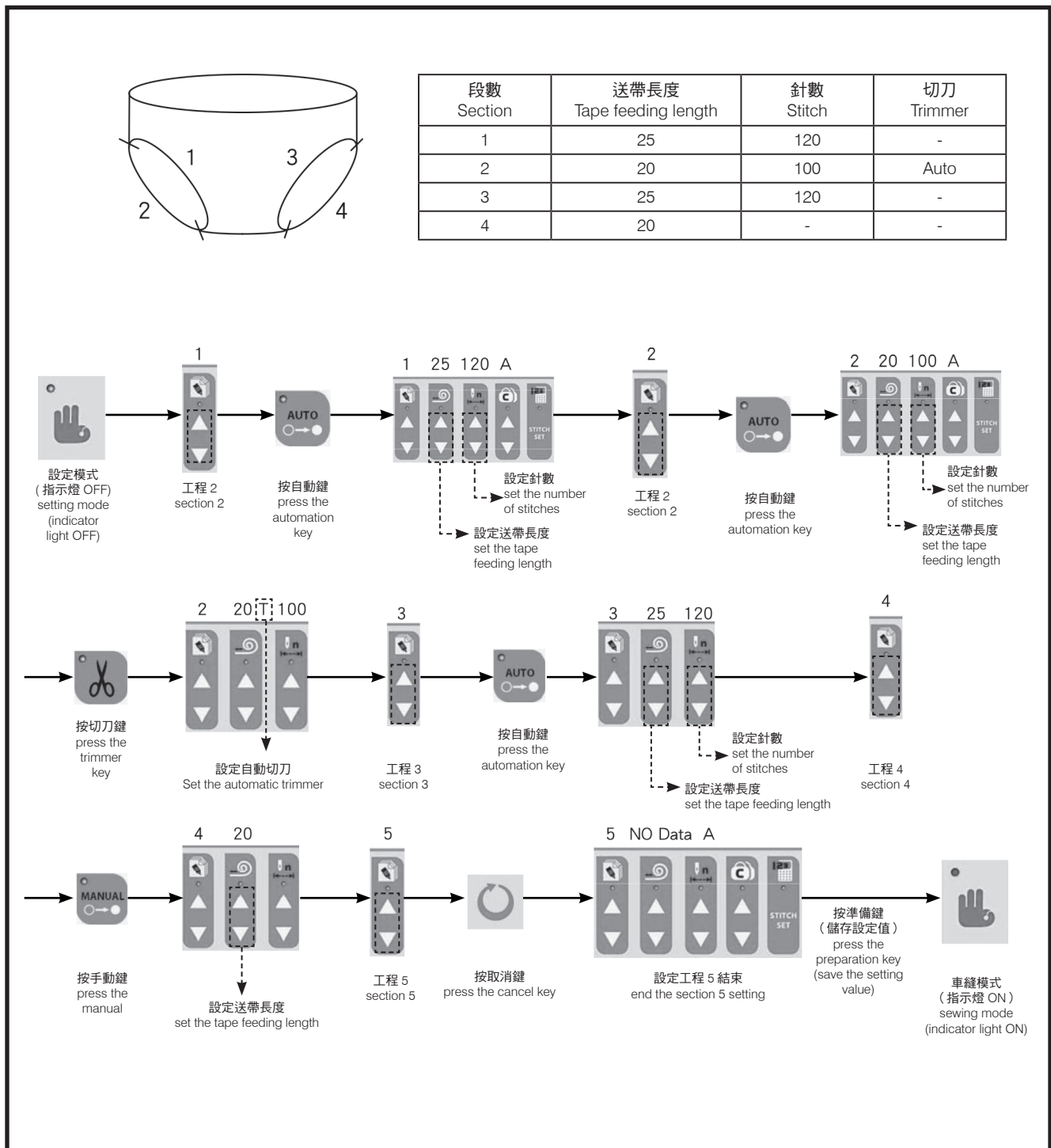

c. 縫紉機啟動車縫時，鬆緊帶自動拉回 30mm。

c. When the machine starts sewing, 30 millimeters of elastic tape is pulled back.

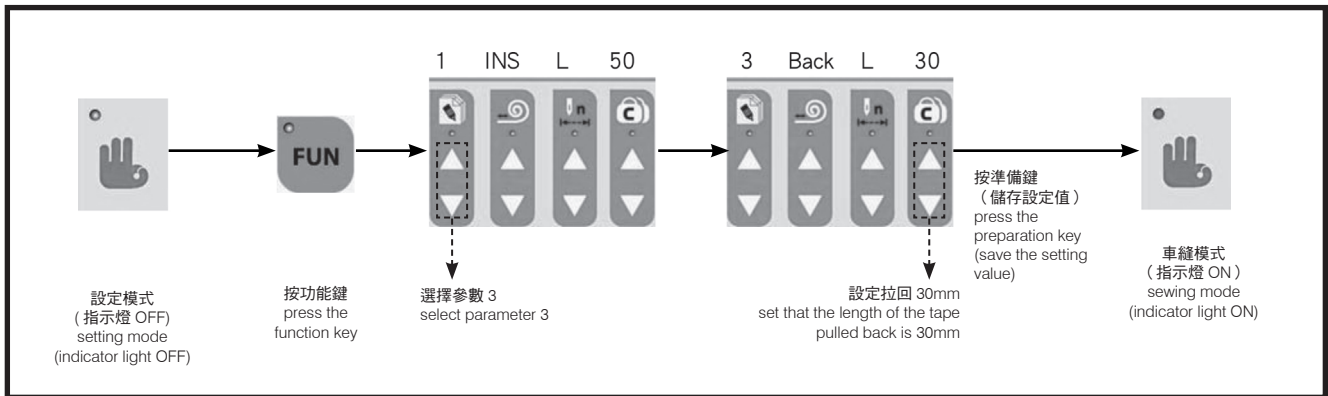

d. 切刀動作完成後再車縫 20 針，啟動吸風集塵與鬆線功能。

d. After the completion of the trimmer, do 20 stitches; then, start the functions of the suction and loosing thread.

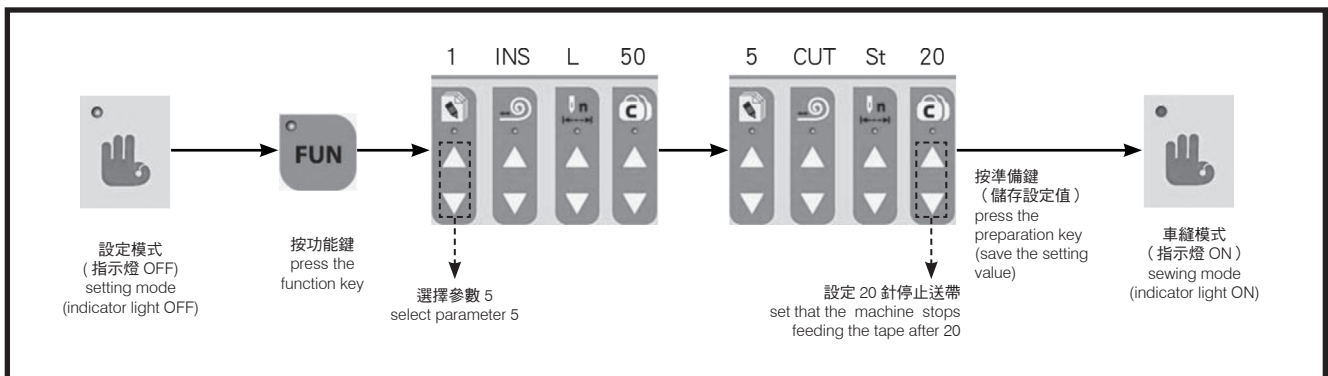

e. 踏板回踩自動執行抬壓腳，並送入鬆緊帶 40mm。

e. The pedal is lowered to automatically raise the presser foot, and 40 millimeters of elastic tape is fed.

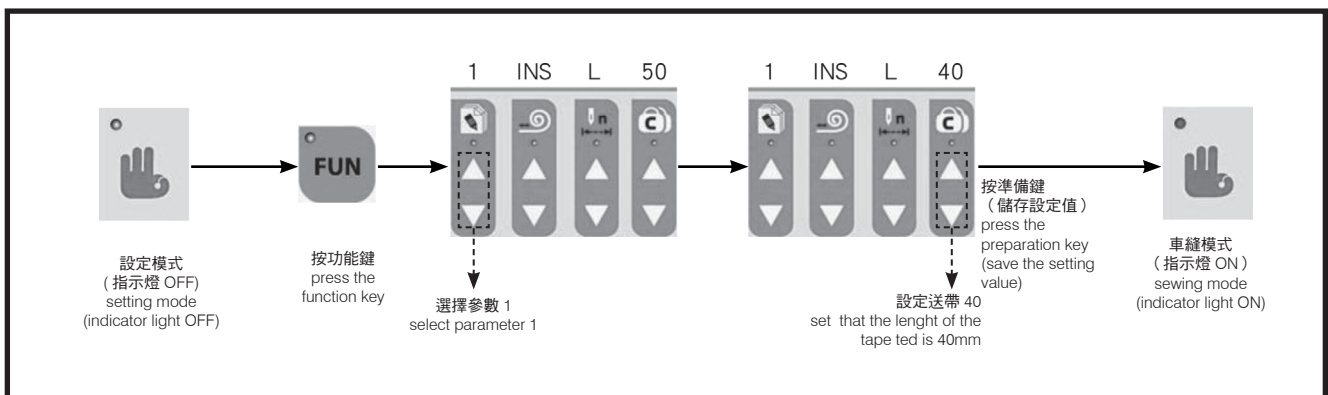

## 故障排除

## TROUBLESHOOTING

### • 電控箱零件配置

• The parts' position in the electronic control box

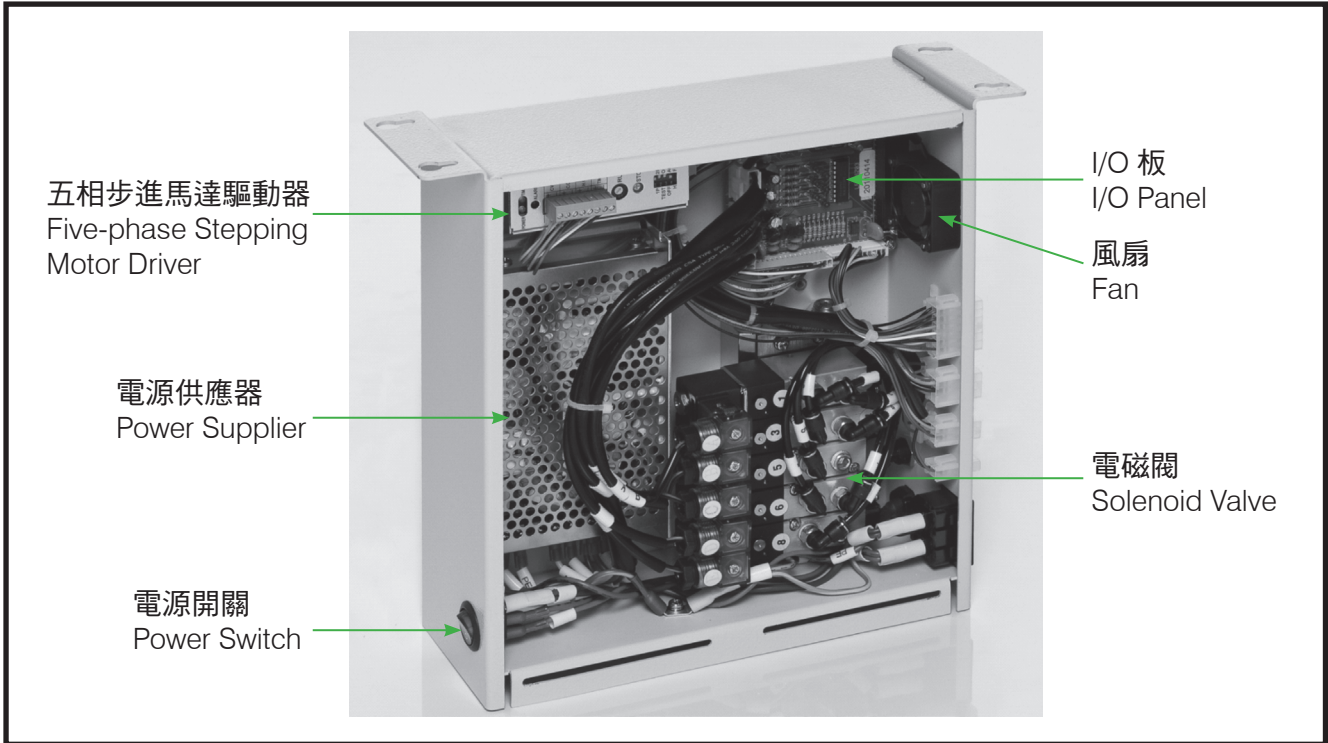

### • 操作板配置

• Operation Board Position

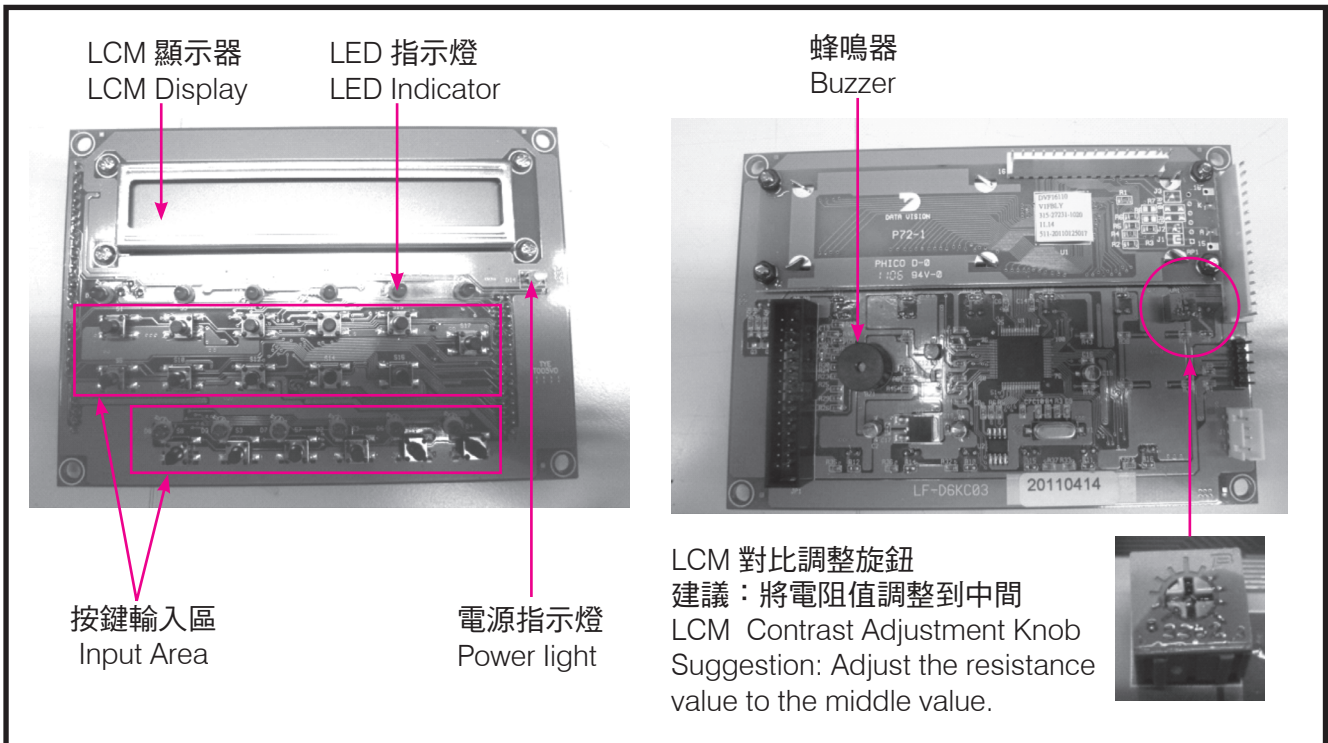



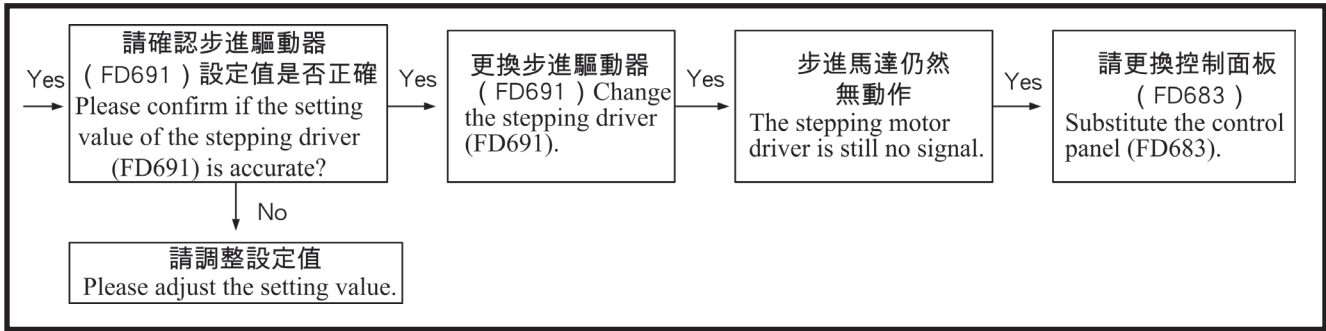

3. 步進驅動器設定

3.The setting value of the stepping motor driver

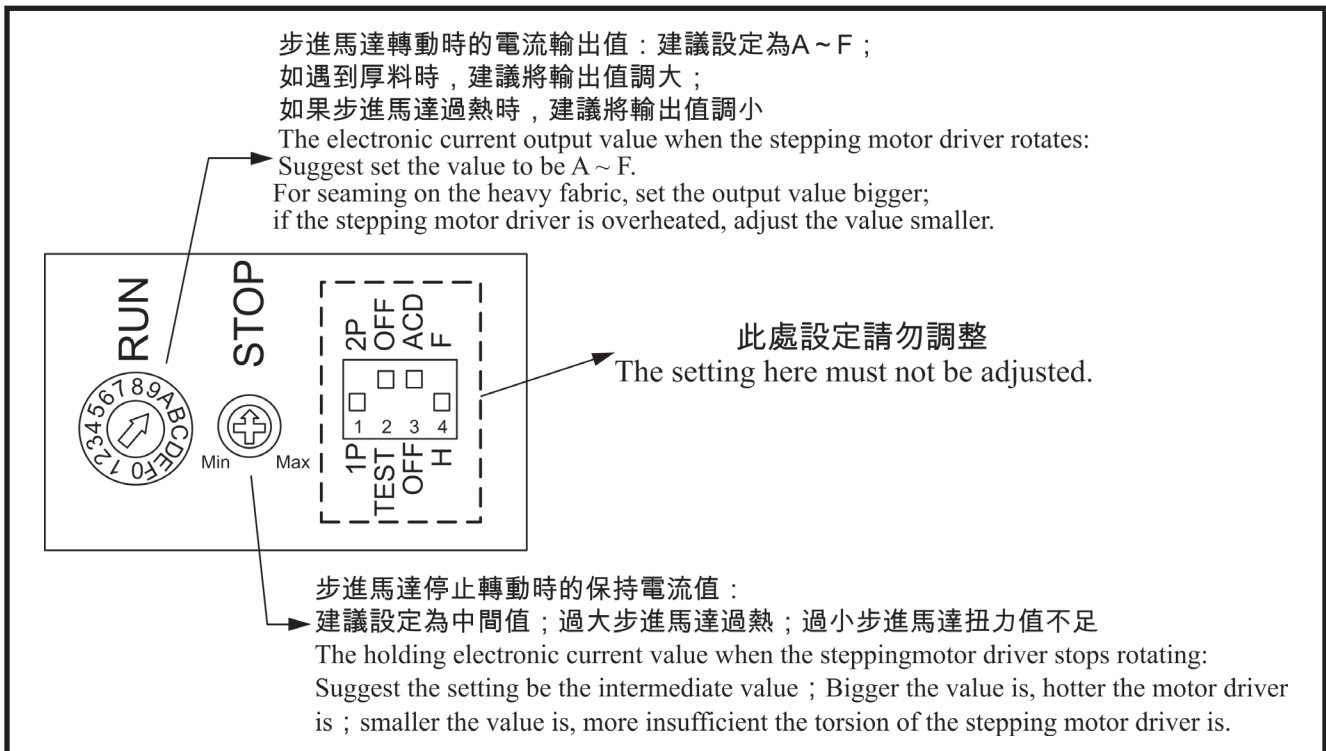

4. 畫面顯示 E01  
表示安全開關被觸動，無法回復。

4.The panel displays E01  
It indicates that the safety lock switch is touched and cannot be reverted.

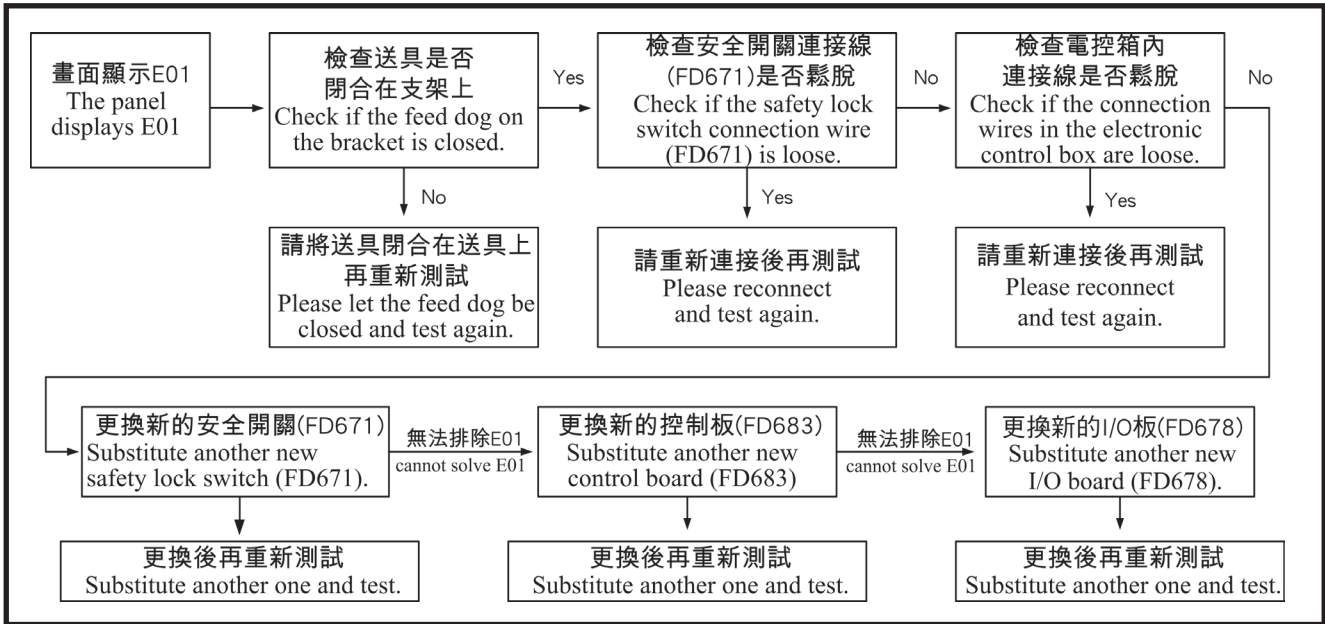

5. 畫面顯示 E02  
表示控制面板上的 EEPROM 異常，無法正  
常動作。

5.The panel displays E02  
It indicates that EEPROM on the control  
panel is abnormal,  
and cannot work regularly.

排除方式：更換新的控制板 (FD683)

Solution: Substitute another new control  
panel (FD683).

6. 畫面顯示 E  
表示圈數檢知器異常，無法正常動作

6.The panel displays E03  
It indicates that the coil detector is abnormal  
and cannot work regularly.

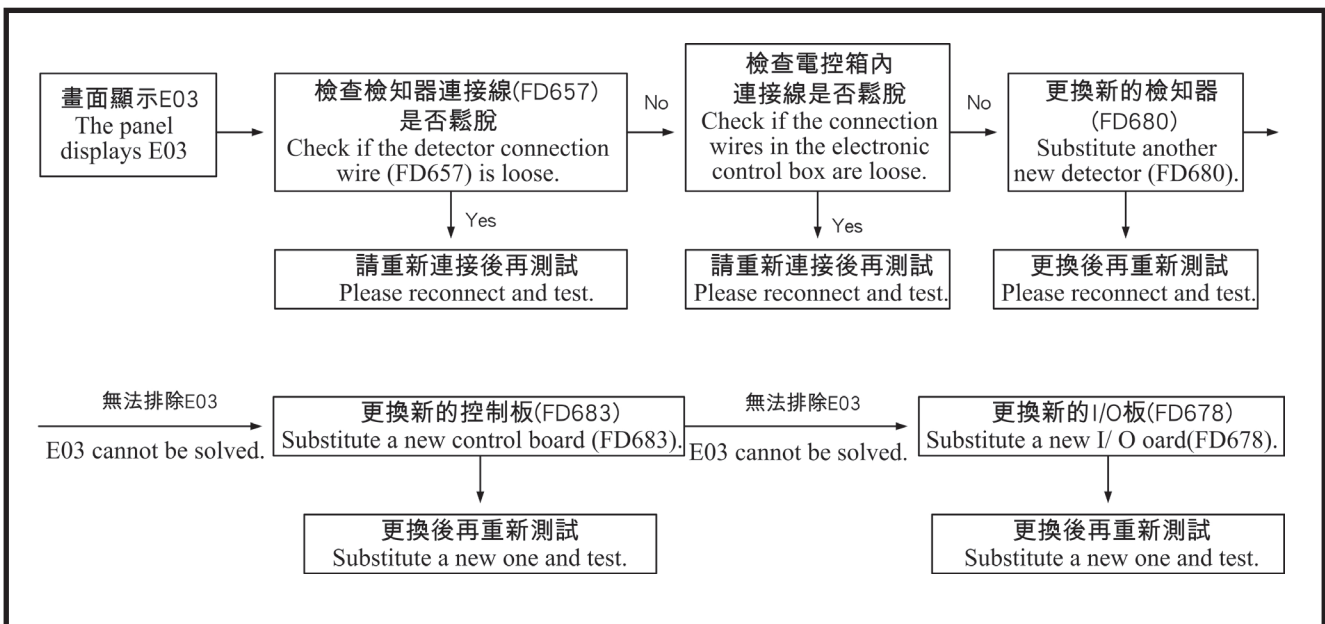

7. 畫面顯示 E04  
表示圈數檢知器異常，無法正常動作

7. The panel displays E04  
It indicates that the coil detector is abnormal and cannot work regularly.

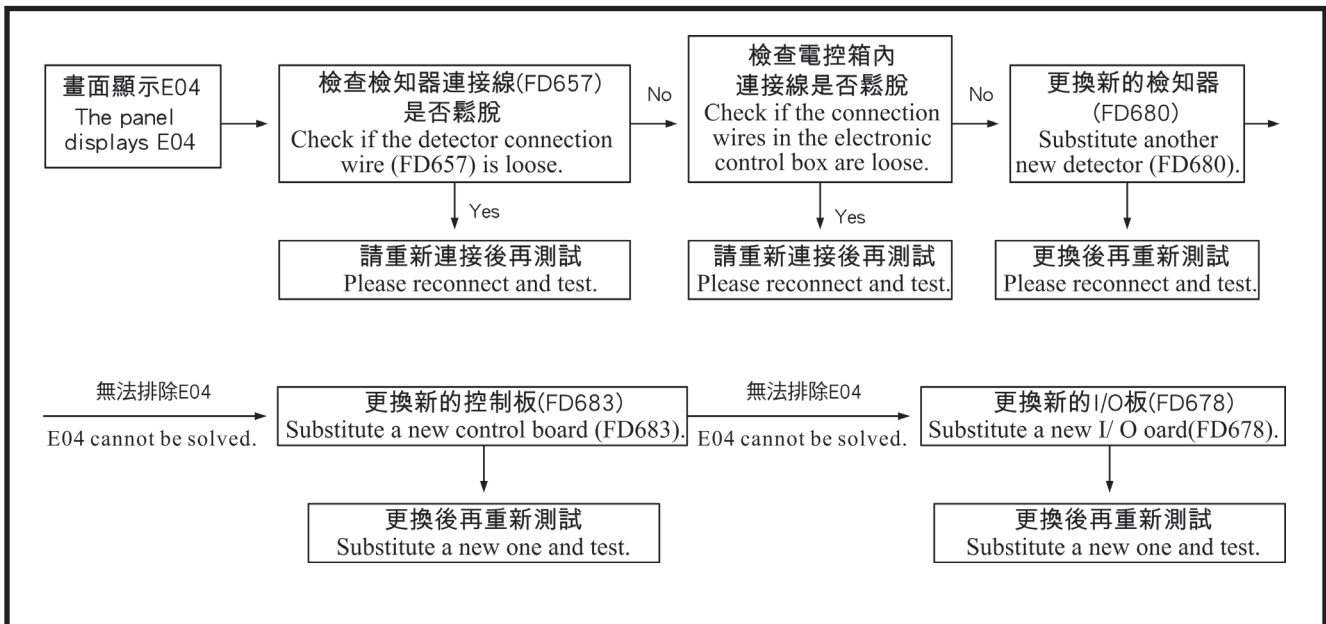

## 簡易維修

## SIMPLE REPAIR

- 五相步進馬達檢測

- Examine the 5-phase stepping motor

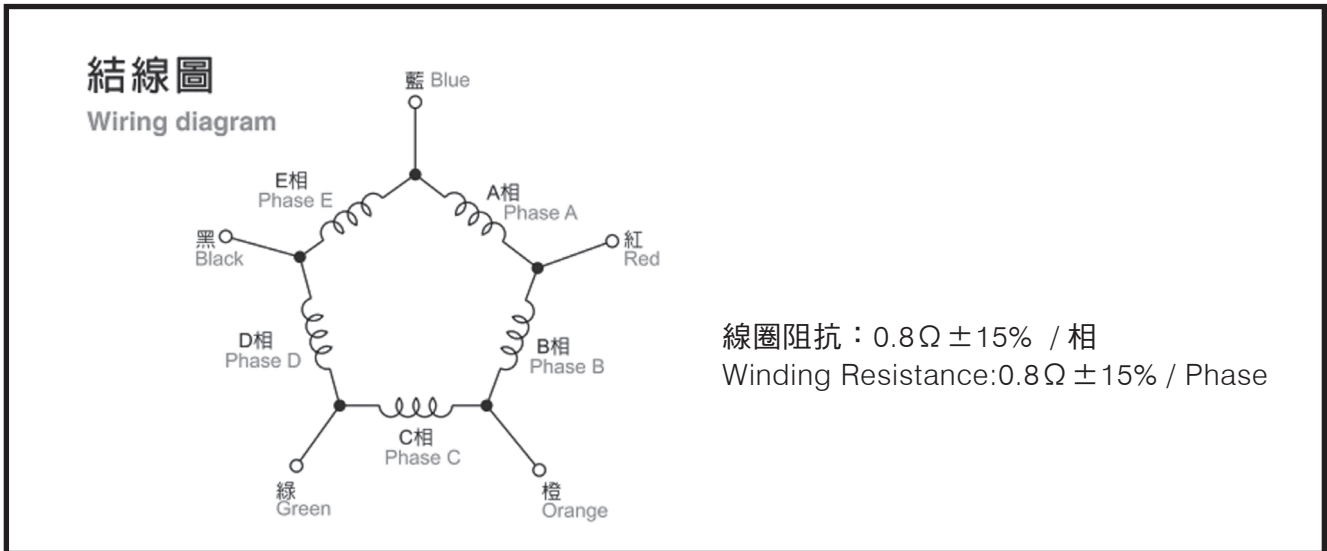

**A：控制系統輸出功能檢測**  
先按住 **STITCH SET** ” 載入針數鍵 ” 然後開機，即可進入系統輸出功能檢測。  
檢測內容：LED 燈號、步進馬達正反轉、LCM 顯示面板、段數顯示器、蜂鳴器、電磁閥組。

**A：Examine the output function in control system**  
Enter the output function in system to examine by keeping pressing the **STITCH SET** “stitch loading key” and then start the machine.  
Examination: LED light, stepping motor driver reversible rotation, LCM display panel, section display, buzzer, and solenoid comb.

**B：控制器輸入功能檢測**  
先按住 **✂** ” 切刀鍵 ” 然後開機，即可進入系統輸入功能檢測。  
檢測內容：人機操作盒所有按鍵。(1) 安全開關、(2) 切刀開關、(3) 換段開關、(4) 回踩開關

**B：Enter the input function in system to examine by keeping pressing **✂** “trimmer key” and then start the machine.**  
Examination: All the keys on the machine box, (1)safety lock switch, (2)trimmer switch, (3)section exchange switch, and (4)back pedal switch.

畫面顯示：**1:0 2:0 3:0 4:1**

The panel shows: **1:0 2:0 3:0 4:1**

**C：控制系統回復出廠設定值**  
先按住 **○** ” 取消鍵 ” 然後開機，即可回復出廠設定值。  
PS：原先的循環縫設定都會被清除。

**C：Revert the control system to the pre-Revert to the pre-programmed value by keeping pressing “cancel key” **○** and then start the machine.**  
P.S.: The initial circulation sewing setting would be eliminated.

<b>SIRUBA</b> TABLE CUT - OUT	Series	Item Code	Subclass Remark	Mounting
	700KS/T	700KS-T5	UNIT: mm TOLERANCE: ±2 WEIGHT: 11.6 kg ±5% For:LFD M/C 需配SM899-A	Non-submerged
				Date
				2014/10/17

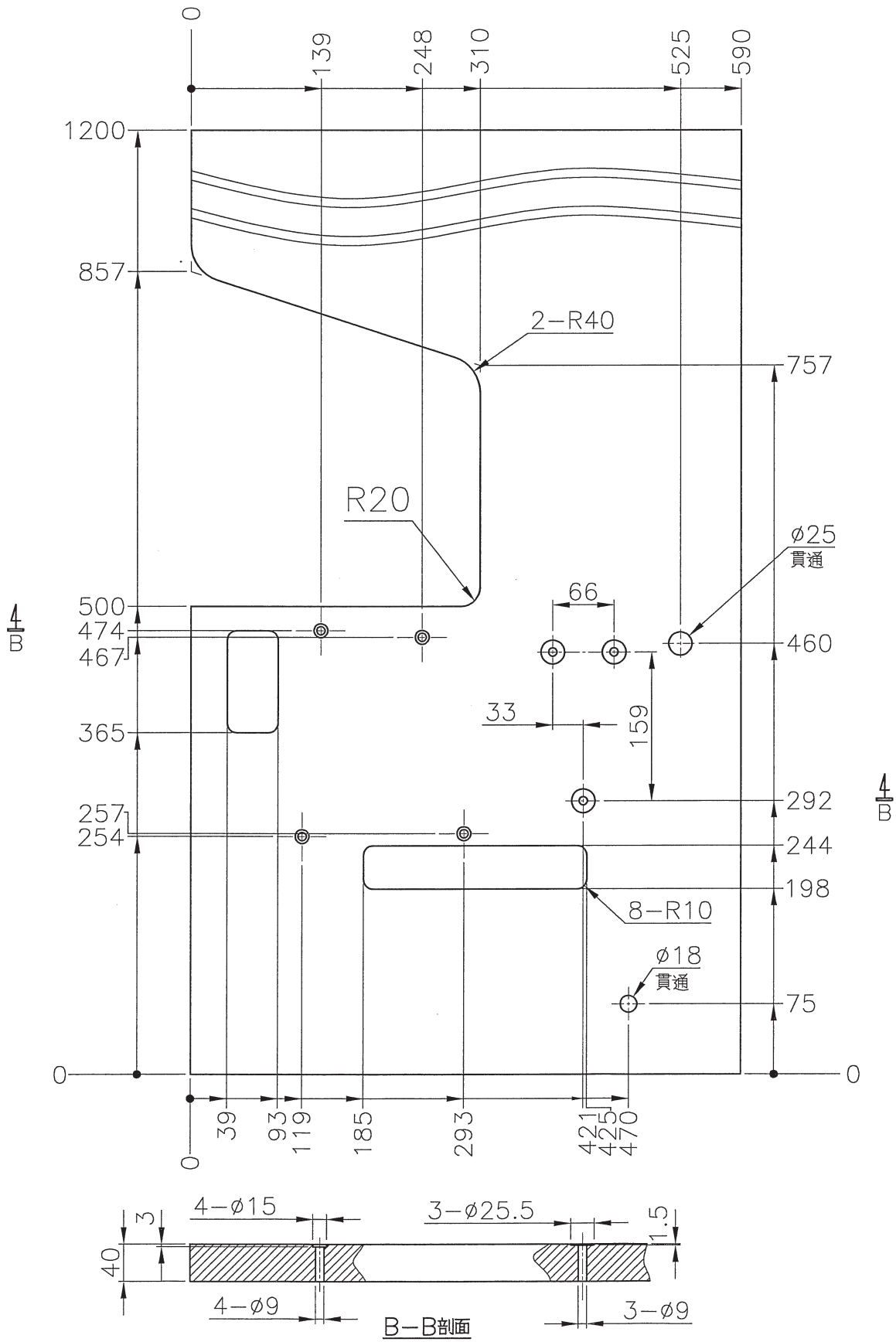

<b>SIRUBA</b> PARTS LIST	Series	Parts Group	Subclass / Remark	Page
	<b>700KS</b>	<b>LFD6-K1</b>	<b>For Short Wheel Cut Limit 20mm</b>	1/12
				Date
				2018/12/13

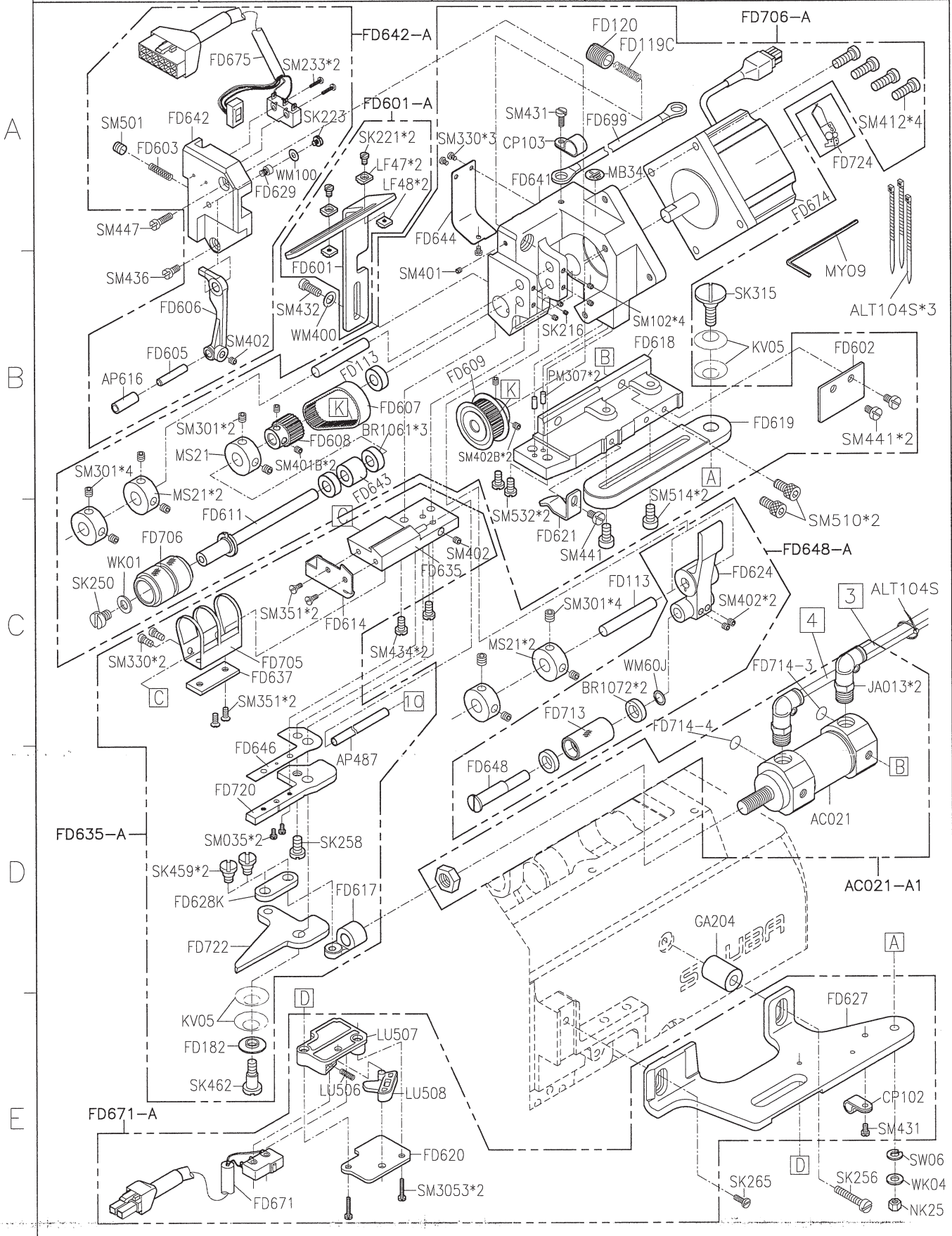

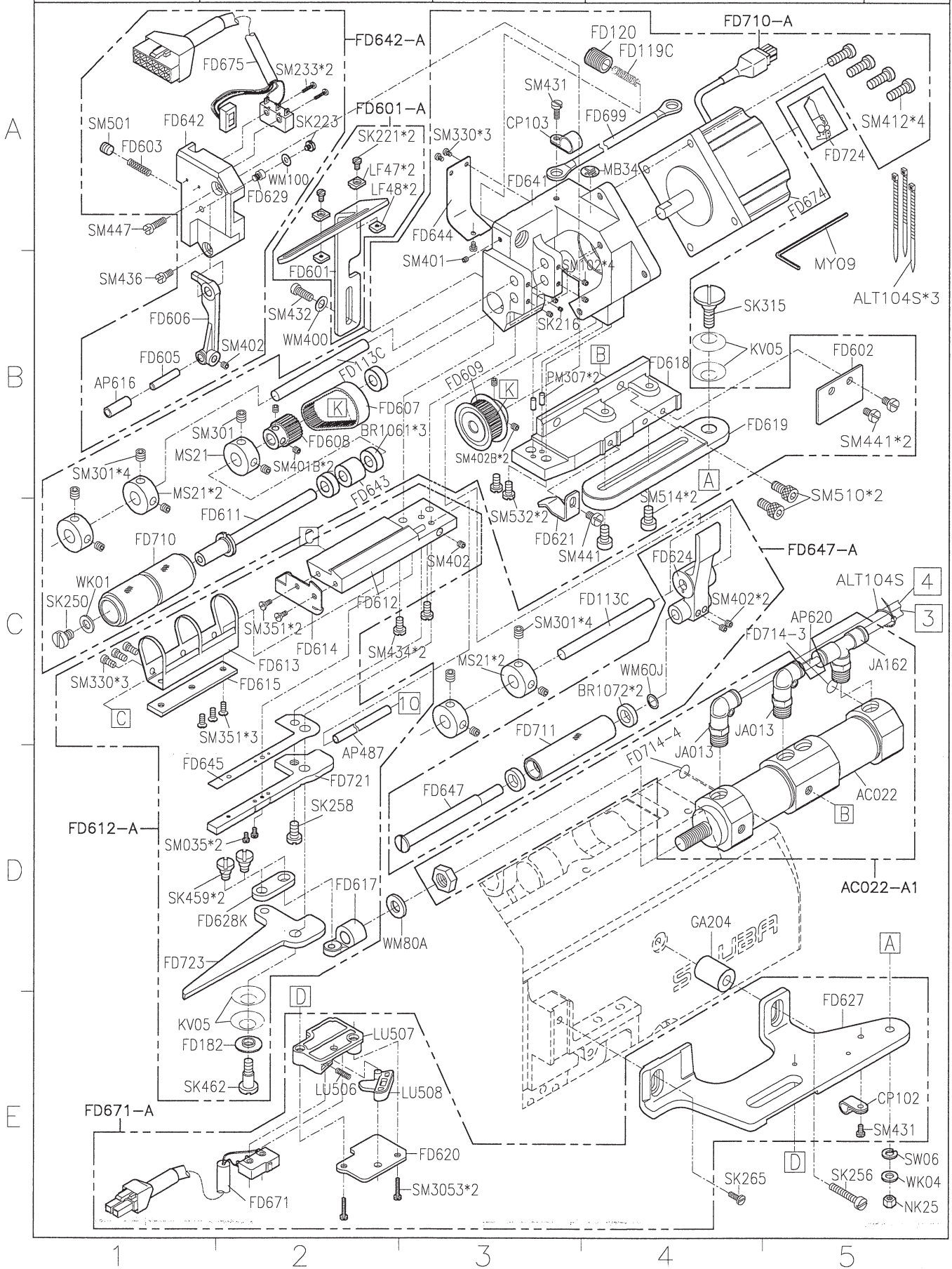

SIRUBA PARTS LIST	Series	Parts Group	Subclass / Remark	Page
	700KS	LFD6-K1		3/12
		LFD6A-K1		Date
				2019/04/23

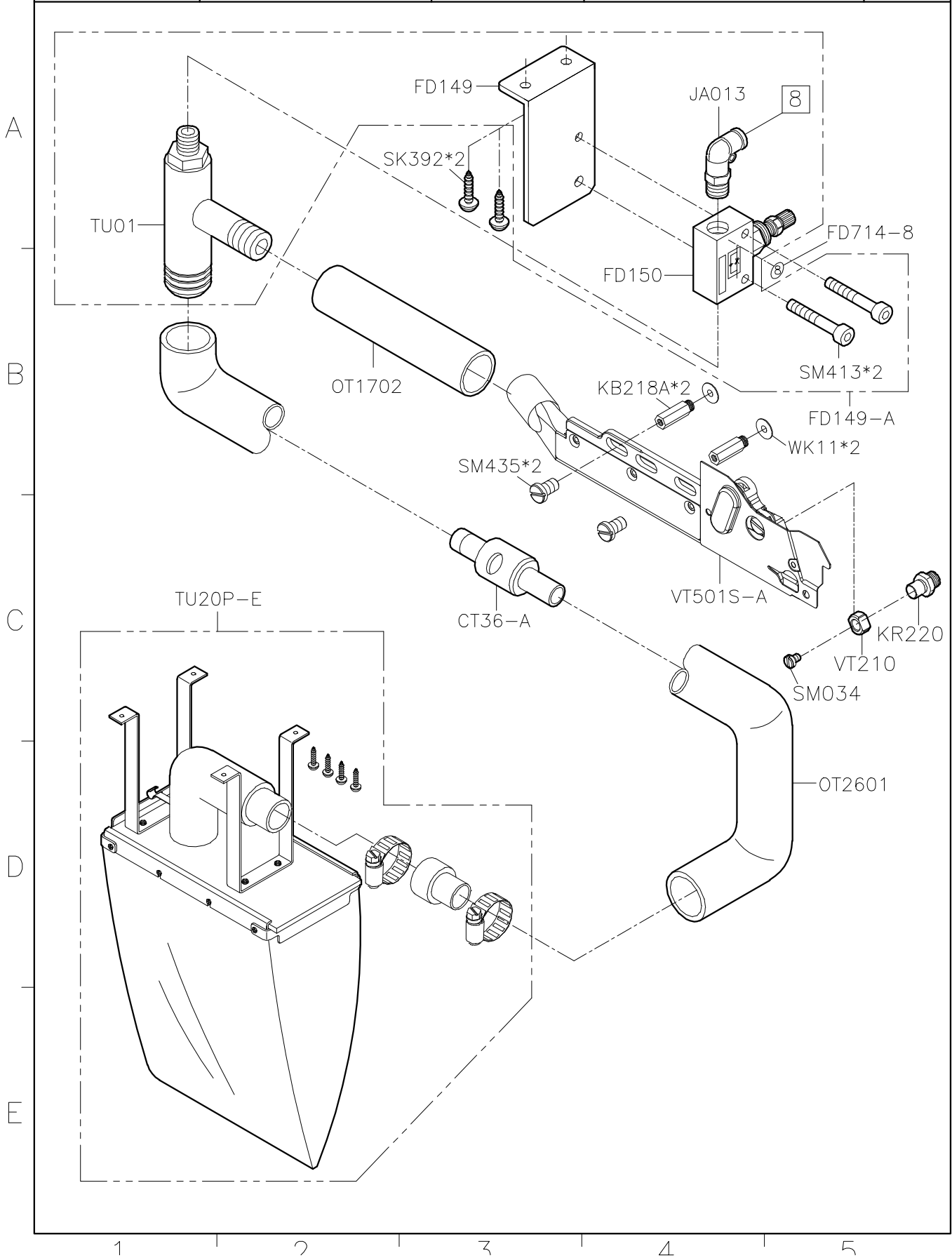

SIRUBA PARTS LIST	Series	Parts Group	Subclass / Remark	Page
	700KS	LFD6-K1 LFD6A-K1	With Thread Release Device 含鬆線裝置 (3線)	4/12
				Date
				2018/3/19

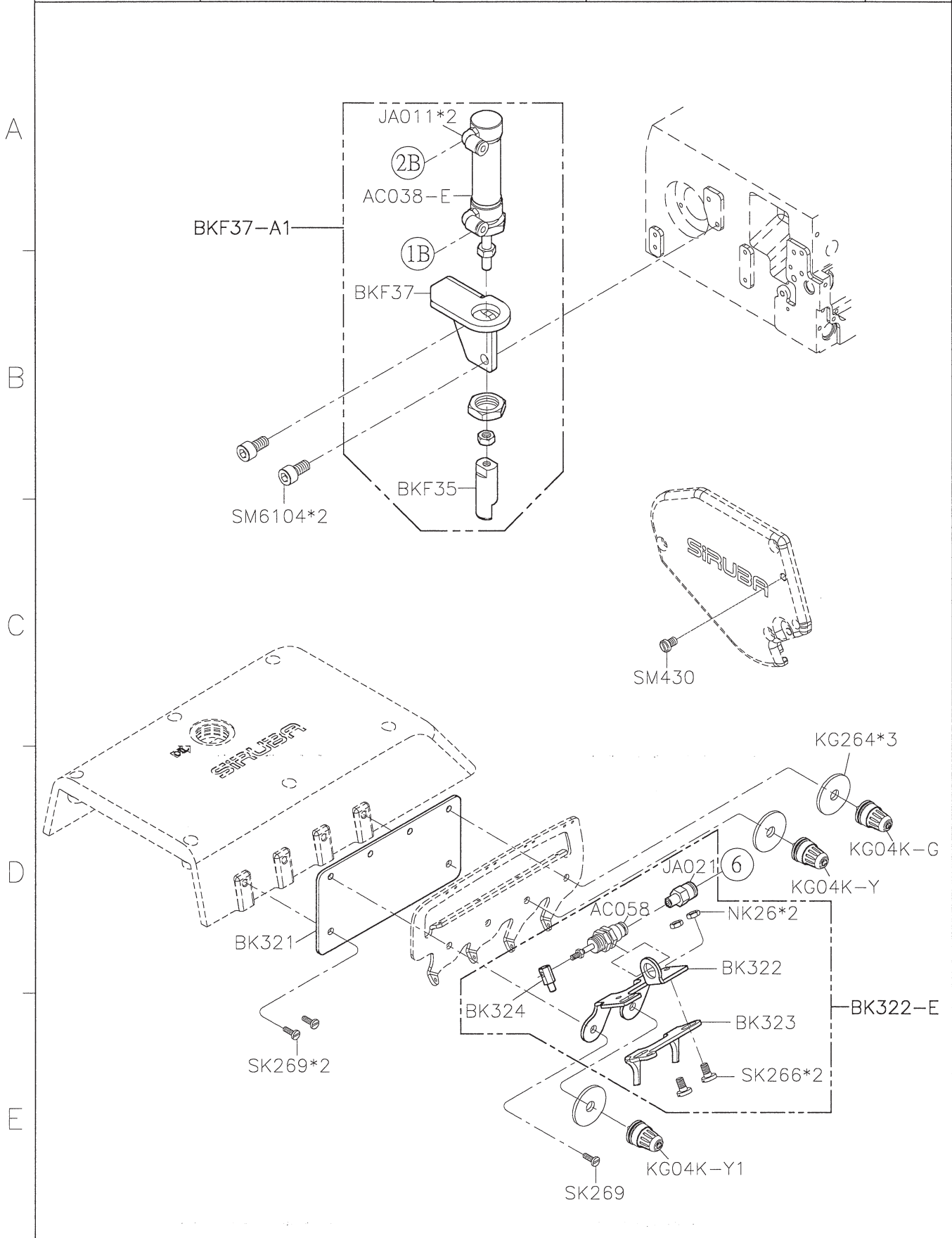

1 2 3 4 5

<b>SIRUBA</b> PARTS LIST	Series	Parts Group	Subclass / Remark	Page
	<b>700KS</b>	<b>LFD6-K1</b> <b>LFD6A-K1</b>	With Thread Release Device 含鬆線裝置 (4線)	5/12
				Date
				2018/3/19

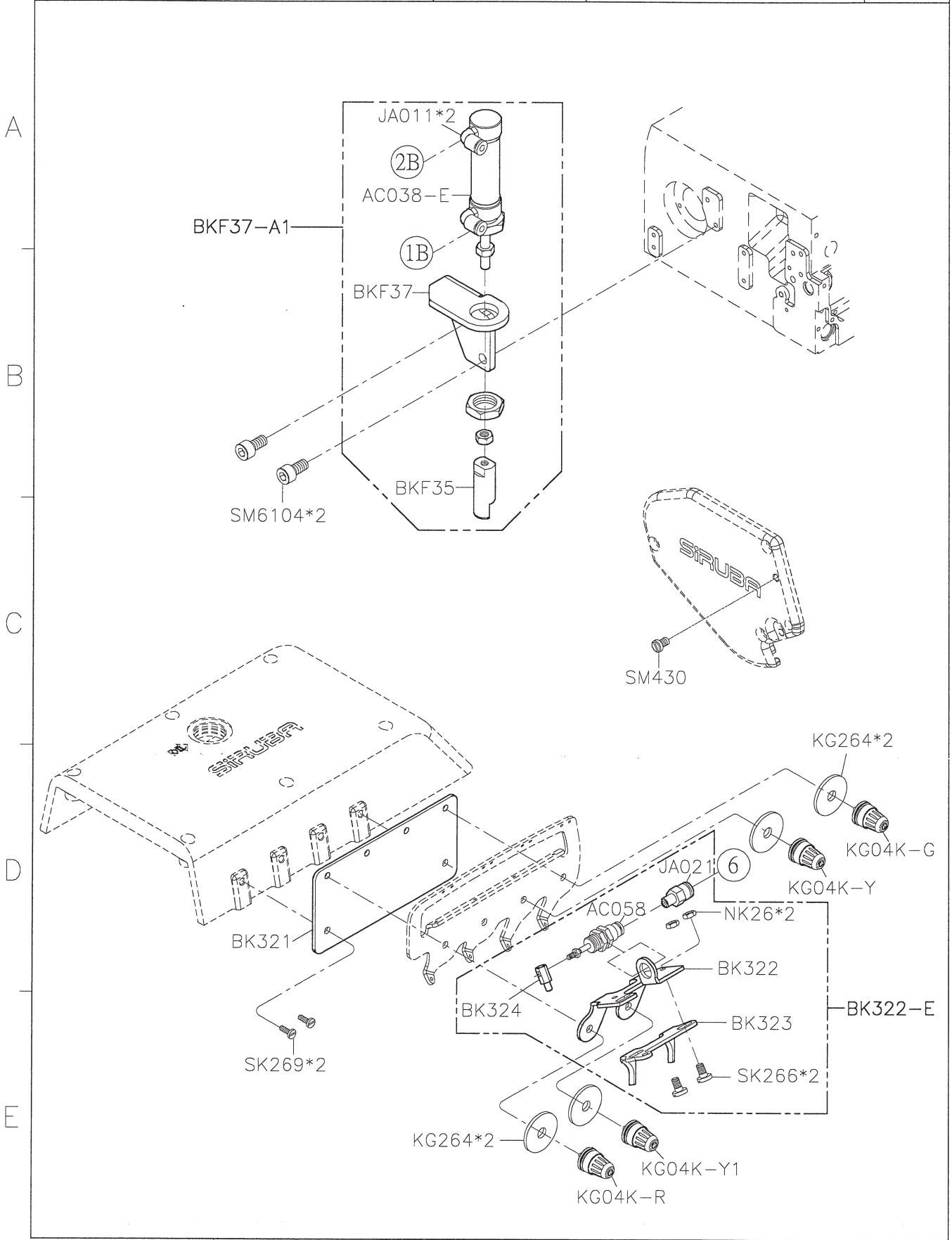



<b>SIRUBA</b> PARTS LIST	Series	Parts Group	Subclass / Remark	Page
	<b>700KS</b>	<b>LFD6-K1</b> <b>LFD6A-K1</b>		7/12
				Date
				2018/3/19

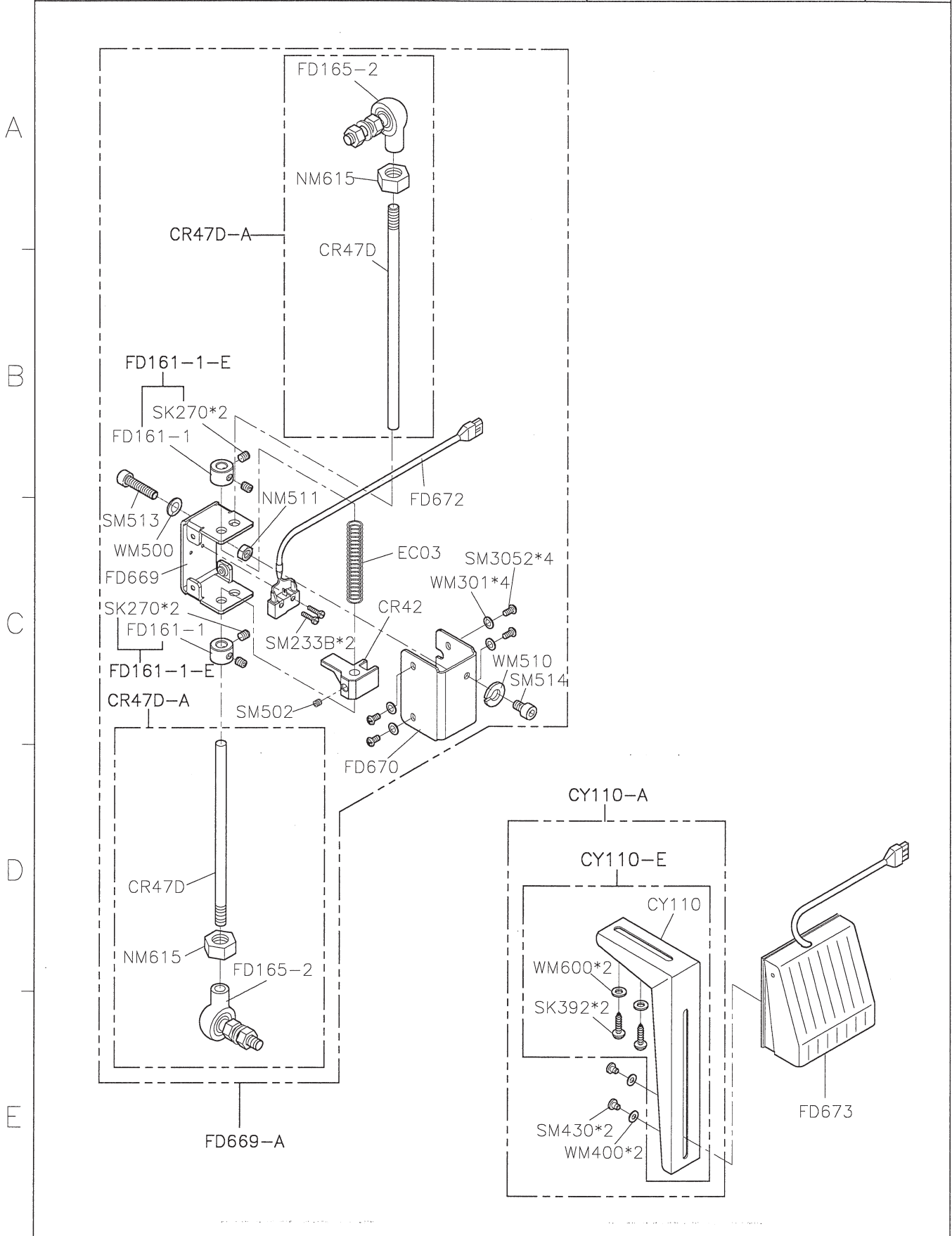

<b>SIRUBA</b> PARTS LIST	Series	Parts Group	Subclass / Remark	Page
	<b>700KS</b>	<b>LFD6-K1</b> <b>LFD6A-K1</b>	@With Thread Release Device @含鬆線裝置	8/12
				Date
				2018/3/19

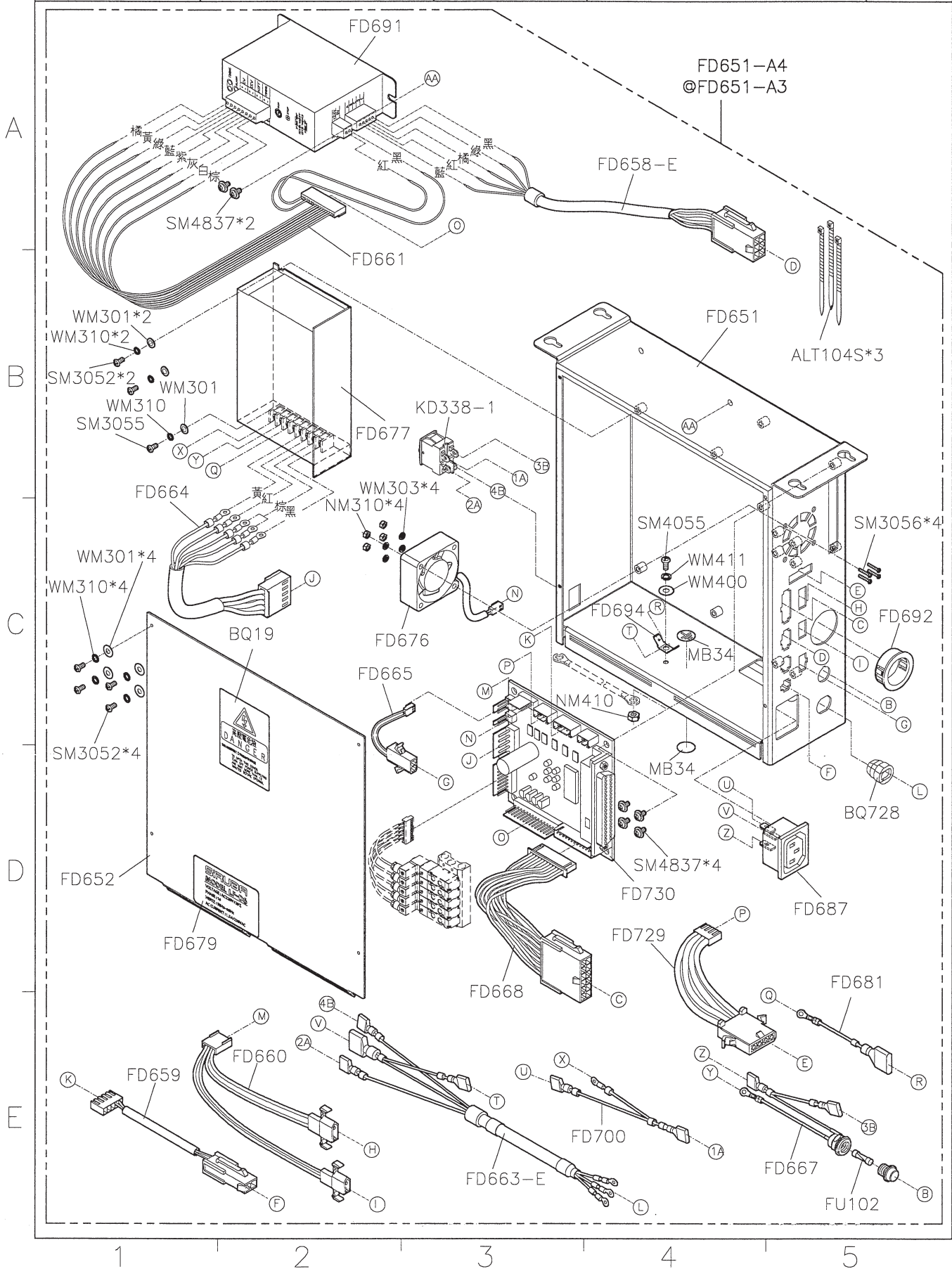

SIRUBA PARTS LIST	Series	Parts Group	Subclass / Remark	Page
	700KS	LFD6-K1 LFD6A-K1	@With Thread Release Device @含鬆線裝置	9/12 Date 2018/3/19

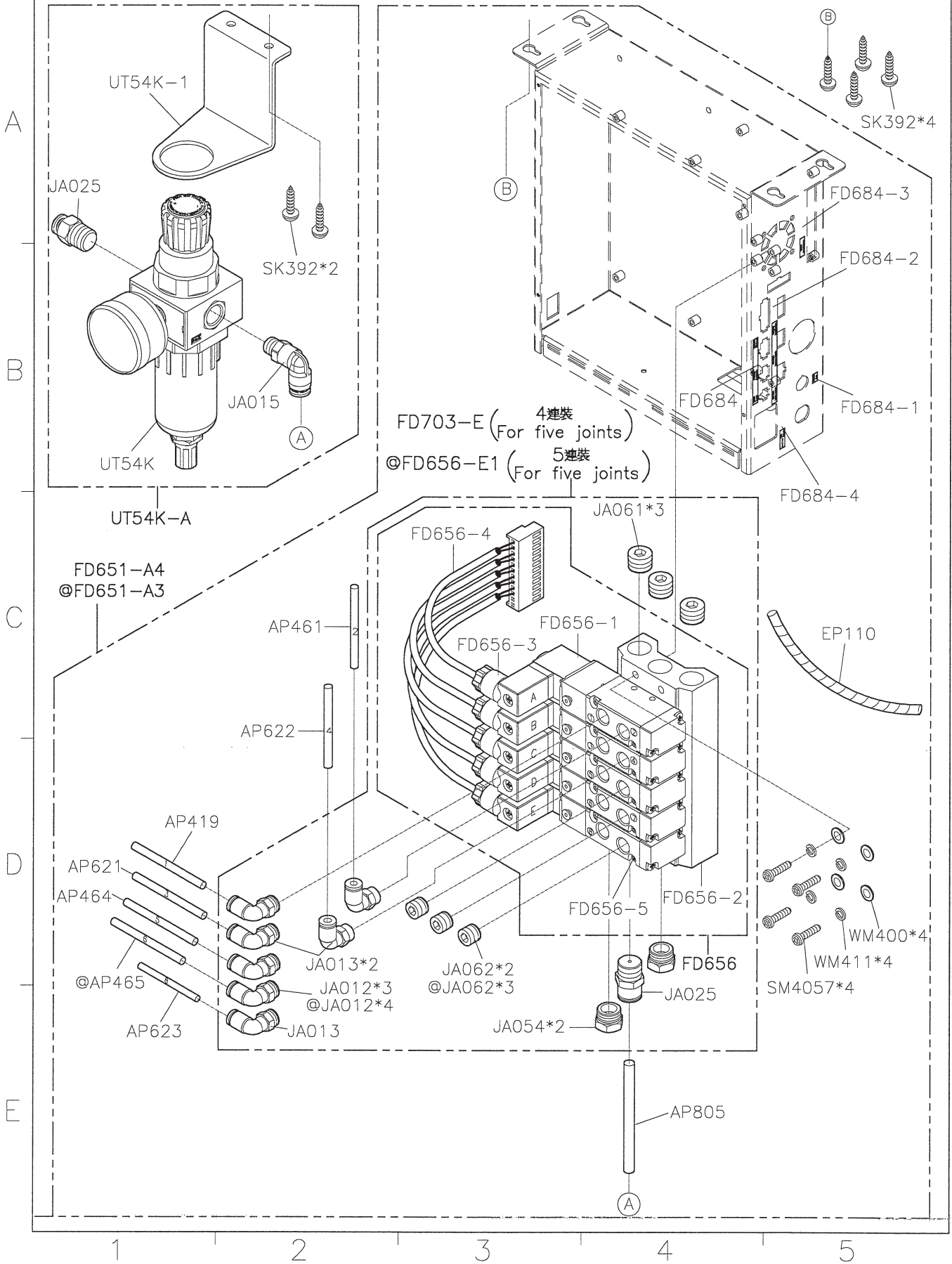

<b>SIRUBA</b> PARTS LIST	Series	Parts Group	Subclass / Remark	Page
	<b>700KS</b>	<b>LFD6-K1</b> <b>LFD6A-K1</b>		10/12
				Date
				2018/3/19

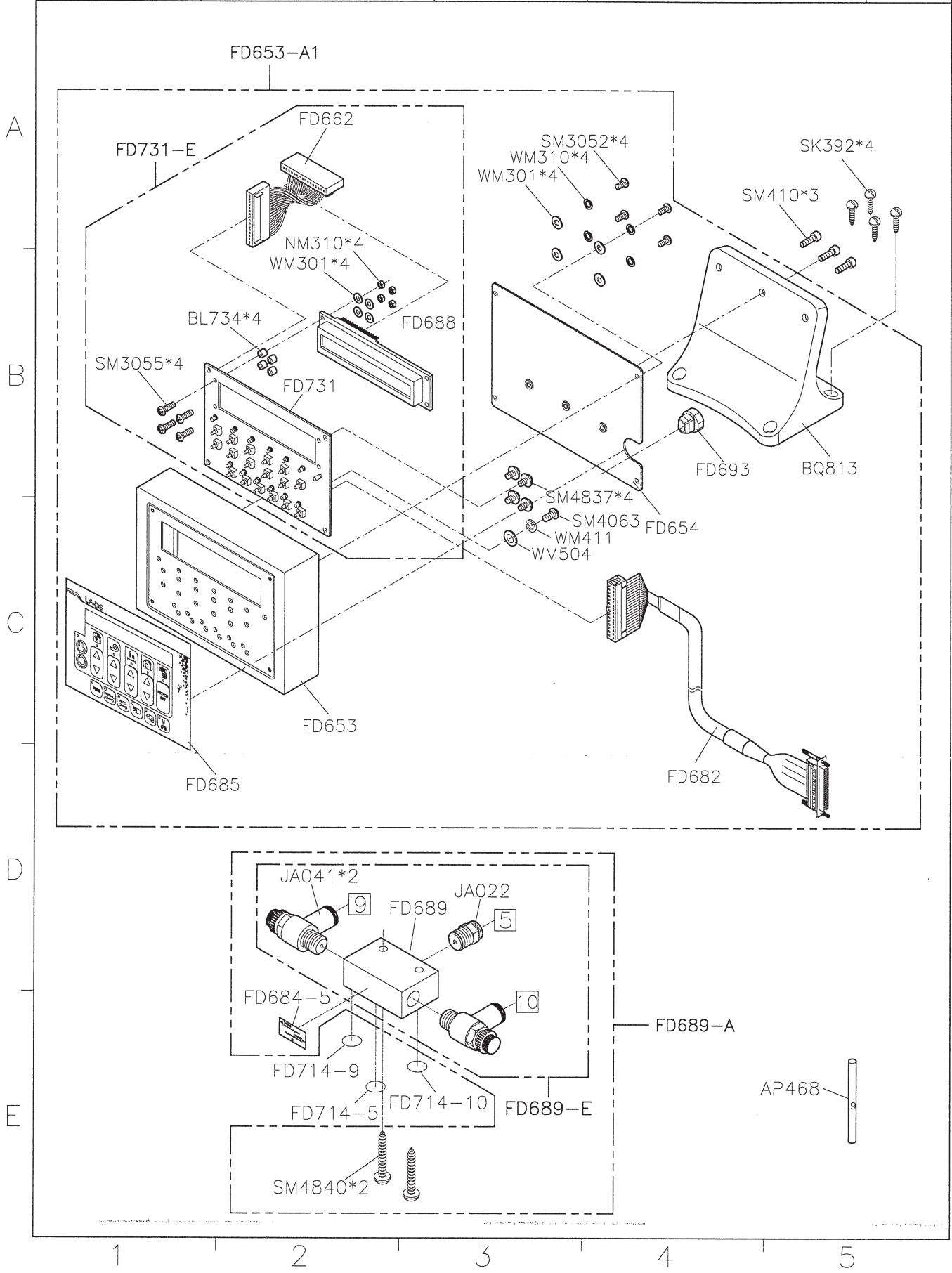

<b>SIRUBA</b> PARTS LIST	Series	Parts Group	Subclass / Remark	Page
	<b>700KS</b>	<b>LFD6-K1</b> <b>LFD6A-K1</b>	@With Thread Release Device @含鬆線裝置	11/12
				Date
				2018/3/19

FD690-A4  
 @FD690-A3

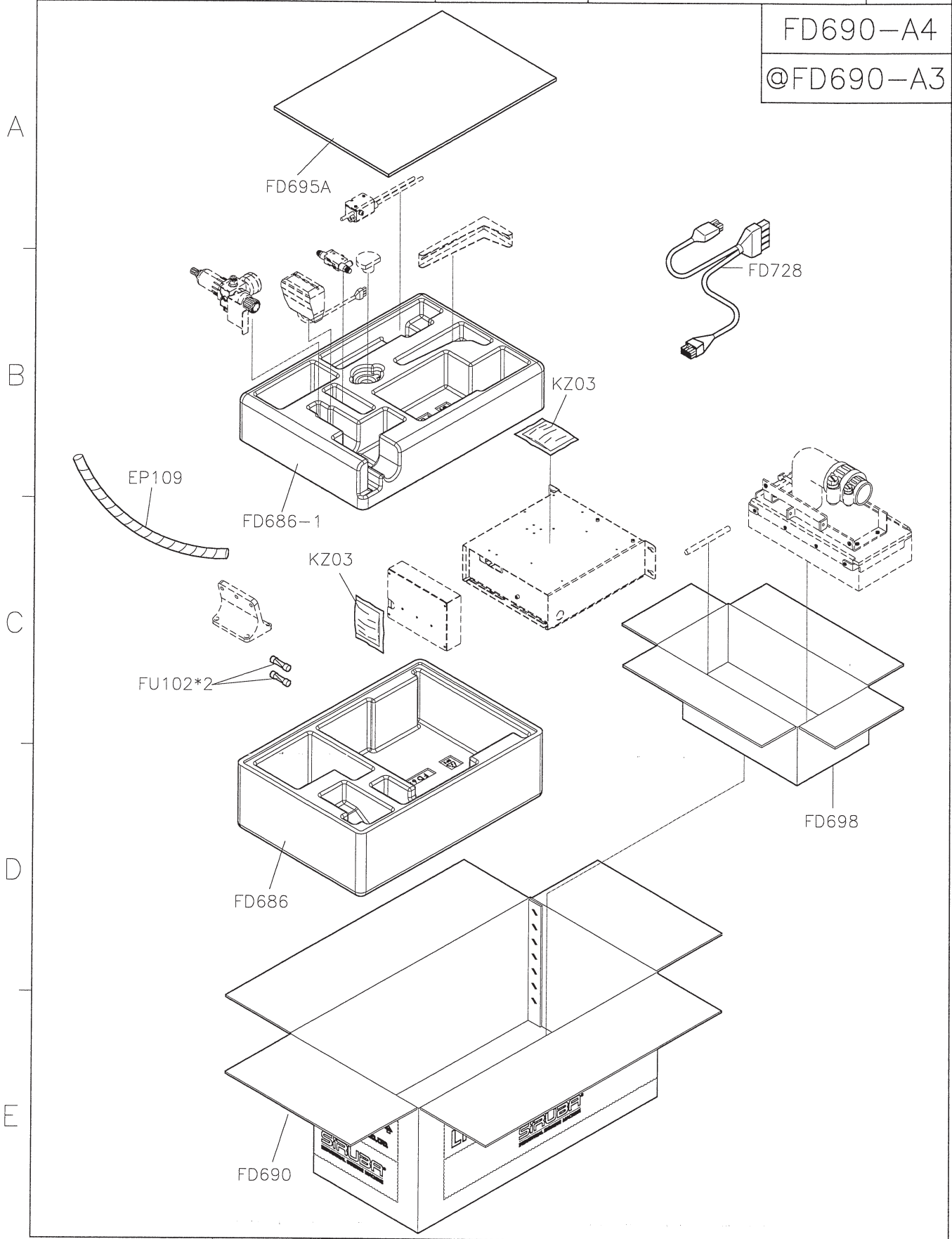



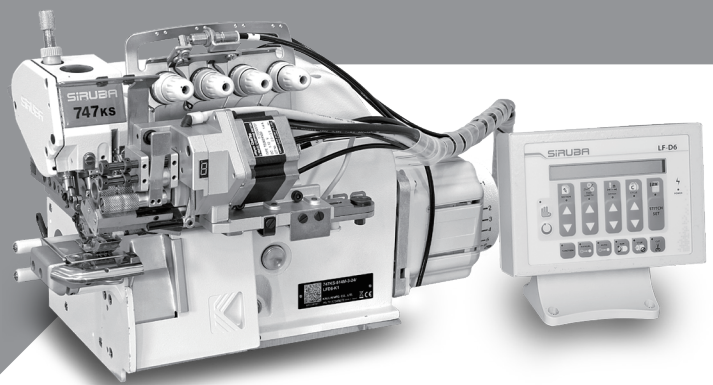

高林股份有限公司  
KAULIN MFG. CO., LTD.

由於對產品的改良及更新，本產品使用說明書中與零件圖之產品及外觀的修改恕不事先通知！  
The specification and/or appearances of the equipment described in this instruction book & parts list are subject to change because of modification which will without previous notice.  
KZ508S-3.MAR.2021