

# SIRUBA

使用說明書與零件圖

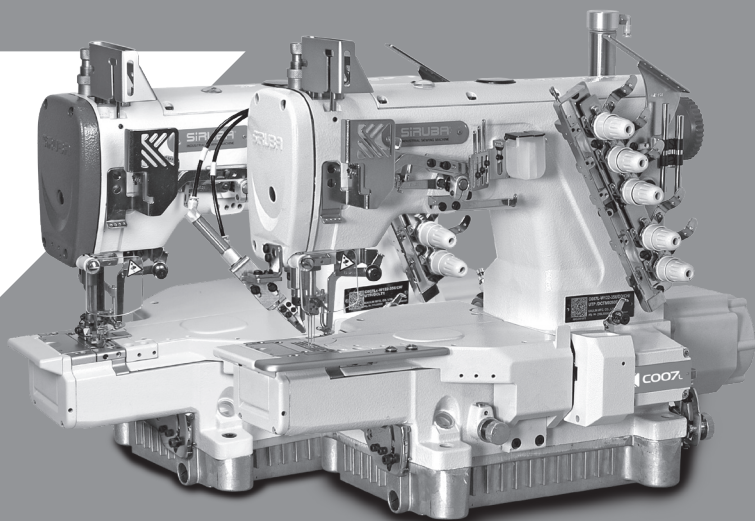

INSTRUCTIONS BOOK & PARTS LIST

■ C007L/C007LX



CE

## 危險水準的說明 Explanation of Dangerous Level

 危險 Dangerous	<p>如果忽視此標記而運行了錯誤的機械操作，保養時肯定會引起當事者或第三者人員重傷或死亡。</p> <p>Don't ignore the warning sign and don't proceed incorrect operation. Or it will cause the person or the third party seriously injured or dead during maintenance.</p>
 注意 Caution	<p>如果忽視此標記而運行了錯誤的機械操作，保養時有可能會引起當事者或第三者人員受傷及造成設備損壞。</p> <p>Ignoring this warning sign and proceed incorrect operation will cause the person involved or the third party wounded and equipment damaged during maintenance.</p>

## 警告圖案表示及表示標誌的說明 Explanation of Warning Signs and Labels

警告圖案表示 Warning Sign		運動部位，謹防工傷事故 Moving part, beware of industrial accident
		高壓部位，謹防觸電事故 High voltage, beware of electric shock
		高溫部位，謹防燙傷事故 High temperature, beware of burns
指示標幟 Instruction Label		禁止 Prohibited
		地線的接線表示 Indication of ground wiring

索引	INDEX	頁 /PAGE
一般安全事項說明	GENERAL SAFETY INSTRUCTIONS	1
重要安全事項說明	IMPORTANT SAFETY INSTRUCTIONS	3
特別事項	WARNING	7
警告標籤	WARNING TAG	8
護針安全圖說	SAFETY ILLUSTRATION OF NEEDLE GUARD	9
搬運縫紉機	MOVING THE SEWING MACHINE	9
關於縫紉機的安裝位置	THE INSTALLATION POSITION OF THE SEWING MACHINE	10
規格	SPECIFICATIONS	10
安全開關及其功能	SAFETY SWITCH AND ITS FUNCTION	11
C007L/C007LX 一般車 定位器之安裝與調整	C007L/C007LX INSTALLATION AND ADJUSTMENT OF SYNCHRONIZER	12
操作步驟	OPERATION PROCESS	13
各部件名稱	NAMES OF MAJOR PARTS	15
機種說明	THE DESCRIPTION OF THE MODEL	16
關於本機的 重要安全注意事項	IMPORTANT SAFETY INSTRUCTIONS OF THIS MACHINE	20
C007L/C007LX 直驅車 馬達安裝方式	C007L/C007LX INSTALL THE MOTOR	21
穿線方法	THREADING	22
拉線鬆緊度調整	ADJUST THREAD TENSION	22
針線挑線桿之調整	ADJUSTING NEEDLE THREAD TAKE-UP	23
壓具之調整	ADJUSTING PRESSER FOOT	24
差動比調整 1:0.6 ~ 1:1.1	ADJUSTING DIFFERENTIAL RATIO 1:0.6 ~ 1:1.1	24

差動比調整 1:0.9 ~ 1:1.4	ADJUSTING DIFFERENTIAL RATIO 1:0.9 ~ 1:1.4	25
差動送布牙的調節	ADJUSTING MOVEMENT OF DIFFERENTIAL FEED DOG	26
縫目長度之調整	ADJUSTING STITCH LENGTH	27
壓具壓力強度之調整	ADJUSTING PRESSURE OF THE PRESSER FOOT	28
操作環境照明	LIGHTENING OF THE OPERATION ENVIRONMENT	28
保養	MAINTENANCE	29
潤滑	LUBRICATION	30
針與線之冷卻與潤滑	LUBRICATE AND THE COOLING OF NEEDLE AND THREAD	31
潤滑油之更換	CHANGE THE LUBRICATION OIL	31
濾油器之更換	CHANGE THE OIL FILTER	32
針之更換	REPLACE THE NEEDLE	32
結束密縫調整	ADJUSTING END INTENSIVE SEWING	33
故障檢修	TROUBLESHOOTING	34
桌板圖	TABLE CUT-OUT	42
零件圖	PARTS LIST	45
報廢流程	DEMOLITION PROCEDURE	69

MODEL		C007L/C007LX Series	
Net Weight(Kg)	45	Noise Level, dB(A)	82dB(A)/4500rpm
Dimension	Length	Width	Height
	46 cm	25 cm	40 cm

## 一般安全事項說明

## GENERAL SAFETY INSTRUCTIONS

### 警告！

當使用這台機器，基本安全預防應恆被遵守，以減輕火災、電擊、或是個人傷害的風險。包含以下注意事項。  
在操作這台機器之前，請閱讀所有說明並且緊記於心。

1. 保持工作場所清潔  
雜亂的環境與椅子會招引危害。
2. 考量工作場所環境  
勿暴露電源於雨水之中、勿在溼氣重的地方或潮濕的場所使用機械器具。保持工作場所良好整齊。當有引發火災或爆炸危險時，勿使用電源工具。
3. 免於電擊危害  
避免身體接觸地線或是接地表面。(即：管線，發熱物體，以及冷凍庫)
4. 勿使孩童接近  
不要讓訪客接觸工具或是延伸管線。
5. 適當的穿著  
不要穿著寬鬆衣物或是穿戴珠寶，這可能被活動零件拉扯而導致危險。穿戴護髮套可包住長髮。
6. 不要任意拉扯電線  
絕不要用電源端拉扯機器，或是從插座猛拉電線來拔掉電線。使電線遠離熱源、油類或是尖銳邊緣。
7. 謹慎保養機器  
遵從指示來添加潤滑油或是更換附件。定期檢測工具用線，如果有所損害，請使用合格的維修器具來修復。

### Warning!

When using this machine, basic safety Precautions should always be followed to reduce the risk of fire, electric shock and personal injury, including the followings. Read all these instructions before operating this product and save these instructions.

1. Keep work area clean  
Cluttered areas and benches invite injuries.
2. Consider work area environment  
Do not expose power to rain. Do not use machine tools in damp or wet locations. Keep work area well lit.  
Do not use power tools where there is risk to cause any fire or explosion.
3. Guard against electric shock  
Avoid body contact with earthed or grounded surfaces (e.g. Pipes, radiators, ranges refrigerators.)
4. Keep children away  
Do not let visitors touch the tool or extension code.
5. Dress properly  
Do not wear loose clothing or jewelry, they can be caught in moving parts. Wear protecting hair covering to contain long hair.
6. Do not abuse the cord  
Never carry the machine by cord or yank it to disconnect it from the socket. Keep the cord away from heat, oil, and sharp edges..
7. Maintain machine with care  
Follow instructions for lubrication and changing accessories. Inspect tool cord periodically. If damaged, have it repaired by an authorized service facility.

## 8. 中斷機器電源

當不使用機器時、維修前、以及更換配件時。

## 9. 避免誤啟動

不要以手指置於啟動開關上之後，搬運一個已插入電源的工具。確定在插電之前，電源開關是關閉的。

## 10. 檢查損害零件

在進一步使用器具之前，應該小心檢查並確認損傷的零件或是穿戴保護器具來確認零件會正確運轉並且呈現應有功能。

## 11. 警告

除了在這本使用說明手冊中建議的功能之外，任何附件或是配件的使用，都可能會導致個人傷害的危險。

## 12. 由合格人員來修理工具

所以修理工作應由合格的人員使用原始個別零件來作修理。

## 連接電源的特別警示！

1. 只可與有 "CE" 認證的按壓啟動裝置連接這台機器。
2. 遵守此使用說明手冊來安裝控制裝置。
3. 在操作過程中，永遠保持機器適當的接地。
4. 在調整、更換零件、或是維修保養之前，必須確定將插頭由插座拔出，以預防任何機器意料之外的啟動而造成危害。

## 8. Disconnect machine

When not in use, before servicing and when changing accessories.

## 9. Avoid unintentional starting

Do not carry a plug-in tool with a finger on the switch. Ensure the power switch is off when plugging in.

## 10. Check damaged parts

Before further use of the tool, a guard or other part that is damaged should be carefully checked to determine that it will operate properly and perform its intended function.

## 11. Warning

The use of any accessory or attachment, other than those recommended in this instruction manual, may present a risk of personal injury.

## 12. Have your tool repaired by a

qualified person







Repairs should only be carried out by qualified persons using original spare parts.

## SPECIAL WARNING FOR ELECTRIC CONNECTION!

1. Incorporate this machine only with "CE" certificate hold-to-run control device.
2. Follow the instruction manual device to install control device.
3. Always earth machine appropriately during operation.
4. Before adjustment, parts change or servicing must be sure to pull out the plug from socket to prevent the hazard of unintentionally start of machine.





## 重要安全事項說明



恭喜您購買本機器，為了使這台機器能獲得最佳功能以及安全的操作，務必請正確的使用這台機器，使用前請仔細閱讀使用說明書，希望您能長期使用它。請記得將此說明書放在容易取得的地方。

-  1. 當您使用機器時，除了以下事項外，請注意其他基本安全措施。
-  2. 使用機器前，除了本使用說明書外，請詳細閱讀其他相關說明書。此外，請妥善保存此說明書，以便需要時可以隨時取閱。
-  3. 先確認機器是符合貴國安全規定及標準後，再使用機器。
-  4. 當機器完成操作時，所有安全配備必須安裝就緒，在缺少所述安全配備下操作是不被允許的，以免導致人員受傷。
-  5. 此機器應由受過適當訓練之操作員操作。
-  6. 為了安全，我們建議您配戴安全眼鏡。
-  7. 以下情形，請先關閉電源或拔掉插頭：
  - (1) 穿針線、導線片、天平等以及更換梭子時。
  - (2) 更換針、壓具、針板、送具、頂針片、車布導板，以及其他附屬配件時。
  - (3) 維修工作時。
  - (4) 離開工作場所或工作場所無人看顧時。

## IMPORTANT SAFETY INSTRUCTIONS

For operating safely and getting the best functions of this machine, you must operate it correctly. Please read and follow the instructions of this manual, and keep it at hand for future references. We are confident that you will enjoy this machine as much as we enjoy manufacturing it.

-  1. Instead of the following instructions, when you use this machine, please pay attention to the basic safety measures.
-  2. Before using this machine, please read this manual and all related instructions. In addition, please keep this manual for future needs.
-  3. Before using this machine, please ascertain that it conforms with safety standards and regulations of your country.
-  4. When the machine is ready for operation, all the safety equipments must be ready. Operate this machine without the specified safety devices is not allowed.
-  5. This machine must be operated by a properly trained operator.
-  6. For your own safety, we suggest you wearing goggles.
-  7. Please turn off the power switch or disconnect it for any one of the circumstances of the followings:
  - (1) When threading needle(s), adjusting thread Take-up(s), thread guide(s), and/or replacing bobbin(s).
  - (2) When replacing needles, presser feet, needle plates, feed dogs, needle guards, cloth guides and other parts or accessories.
  - (3) When repairing.
  - (4) When the operator leaves the working place or leaves the machine unattended.

 8. 假如不慎讓機器及配件使用之油或油脂，接觸到眼睛、皮膚或誤食時，請立刻以水清洗接觸部位及就診。  



 9. 請勿擅自碰觸運轉中之零件及配件及注意機器電源是否已開啟，以免導致人員受傷。

 10. 維修、修改及調整等工作，須由受過適當訓練的技師或熟手為之。維修時只許使用指定之零件。

 11. 一般維修及檢查工作必須由受過適當訓練的人員為之。

 12. 電子零件維修及保養工作必須由資深的電子技師為之，或由非常熟練的人員檢查及指導，當發現零件損壞時，請立刻停止機器運轉。

 13. 在做裝有氣動式零件（例如氣缸）機器的維修及保養工作前，機器連接空壓機及高壓空氣必須予以關閉及卸除，機器中殘存高壓氣體必須予以消除，此外調整及性能檢查只能由受過適當訓練的技師或熟手為之。

 14. 機器使用一段時間，必須定期清理。

 8. If grease, oil, or any fluid contacts your skin or eyes by any chance, please wash the contacted area completely with clean water and consult a doctor. Or, swallow any fluid mistakenly, consult a doctor immediately.

 9. Do not touch any functioning parts and devices. Always attend to whether power switch is on or off before operating in order to prevent anyone from getting hurts.

 10. Qualified technicians are required for adjustment, modification, and repair. Only use assigned parts for replacement.

 11. Routine maintenance and service must be performed by well trained persons, or qualified technicians.

 12. Maintain and check the electronic parts must be done by qualified electrician or well-trained persons. If any electronic part damaged or malfunctioned, stop the machine immediately.

 13. The air house has to be detached from the machine and the compressor or air supply has to be cut off before repairing and servicing the machine equipped with pneumatic parts such as an air cylinder. Qualified technicians or well-trained persons are required for adjustment and repairs.

 14. To ensure the best performance, periodically clean the machine is necessary.

 15. 為使機器能正常操作以及減少噪音，機台務必平放地上，機器避免在強烈噪音的環境下操作。

 16. 選用適當的電源插頭，並由電子技師將其安裝在機器上，且插頭必須插在接地線之插座上。

 17. 機器只允許被使用於指定用途上，其他用途是不允許的。

 18. 修改或變更機器必須依照安全規定及標準，同時採取有效的安全措施或變更機器所引起損壞之責。

 19. 警告提示以兩種符號標示：

(1) 對操作員或服務人員之傷害危險，也為了避免觸電之危險，請勿打開馬達電器箱之外蓋，也不要觸摸電器箱裡面之零件。

 (2) 必須特別注意事項  
a. 絕對不可在移動外蓋，手指保護蓋或安全配件後，進行機器操作，以免導致人員受傷。

b. 為了避免被機器纏住，當機器運轉中，您的手、頭髮及衣服，需遠離手輪；此外這些部位周圍不可放置任何物品，以免導致人員受傷。

 15. In order to operate properly and to reduce the noise, please place the machine flat and level on the ground. Avoid operating the sewing machine at a noisy surrounding.

 16. Select a proper power plug and install it by an electrician. Please connect the power plug to a grounded receptacle.

 17. This machine can only be used for the designed purpose. Other uses of this machine are not allowed.

 18. Any modification or conversion made on this machine must be conformed with the safety standards and regulations. Precaution is necessary. No responsibility will our company take for damages caused by any modification or conversion of this machine without permission.

 19. Two safety warning signs are applied as warning signs:

(1) For the safety of operators and service persons, please don't open the cover of any electronic control boxes of motor or other devices and don't touch any components inside to avoid electrical shock hazards.

 (2) Always keep in mind:  
a. Please never operate this machine without outer cover, finger guard or any safety device to avoid physical injury.

b. Please keep your hair, fingers and clothes away from the hand wheel while the machine is in operation, as well as never put anything near these parts, to prevent the risk of injuries by tangled into them.

 c. 當您打開電源開關後或機器已在運轉中，絕不可將您的手放在針的下方或針線控線桿外蓋中，以免導致人員受傷。

 d. 當機器運轉中，梭頭高速轉動，為了避免對手可能引起之傷害，必須確定您的手保持遠離梭頭附近。此外，當更換梭子時，確定電源開關已關閉，以免導致人員受傷。

 e. 當放置或抬起機器時，小心勿將手置於機器中，以免導致人員受傷。

 f. 為了避免機器突然啟動而引起可能意外，當機頭傾斜時，請關掉機器電源，以免導致人員受傷。

 g. 如果您的機器是配置伺服馬達，機器於靜止狀態時，馬達是不會產生噪音的，為了避免機器突然啟動而引起可能意外，故請關掉機器電源。

 h. 為了避免觸電之危險，請絕不要在移開電源接地線後操作機器。

 i. 為了避免觸電或電子零件損壞而引起之可能意外，請先切斷電源，再插上或拔掉插頭。

 c. Please never put your fingers under the needle(s) or in the thread take-up cover to prevent physical injuries when you turn on the power switch or operate the machine.

 d. While the machine is in operation, the hook rotates at a high speed. Please keep your hands away from the area of hook to prevent any potential injury to your hands. In addition, please make sure to turn off the power of the machine while changing bobbins.

 e. Be careful and do not place your fingers inside the machine when placing or lifting the machine head to avoid possible physical injuries.

 f. Please turn off the power before tilting the machine head to avoid possible accidents due to abrupt start of this machine.

 g. For machine equipped servo motors, the motors do not produce noise while the machines are at rest. Therefore, please turn off the power of this accidents due to abrupt start of the machine.

 h. Never operate the sewing machine after the ground wire is removed to avoid electrical shock hazards.

 i. Please turn the power switch off before connecting or disconnecting the power plug to prevent possible accidents due to electric shock or damaged electronic components.

## 特別事項

## WARNING

為了避免機器故障及損壞，請先確定以下事項：



1. 當您安裝好機器後，做第一次機器操作前，請徹底清潔機器。



2. 清除運送途中累積之灰塵及溢出之油脂。



3. 確定電壓及馬達相數（單相或三相）安裝正確。



4. 確定電源插頭正確地接上電源。



5. 當使用電壓與標示電壓不同時，請勿使用機器。



6. 確定機器轉動方向是否正確。



警告：

在操作或調整本書中所提到之各步驟前，請先將電源關掉，以免因為機器突然啟動造成之意外。

Please confirm the followings to avoid malfunction or damage to this machine.



1. After installing the machine, and before the first operation, please clean it completely.



2. Clean all dust and overflowed oil during transportation.



3. Confirm that the voltage and the phase (single or 3 phase) of motor are set correctly.



4. Confirm that the power plug is correctly connected to the power supply.



5. Never use the machine when the local voltage type is different from the marked voltage on the nametag attached on the machine.



6. Confirm that the rotating direction of the machine pulley is correct.



Warning:

Before doing any operation or any adjustment described later in this manual, please turn the power off to prevent accidents caused by abrupt start of the sewing machine.

## 警告標籤

## WARNING TAG

- 縫紉機上有下列警告標籤。(圖 1、2)
- 當使用縫紉機時，請遵守標籤上的說明，如果標籤脫落或模糊不清，請和購買商店聯繫。

- The following warning tags will be attached on the sewing machine. (Fig.1, Fig. 2)
- When using the sewing machine, please follow the instructions of the tags. Please contact the dealer if any of the tags is fallen off or fuzzy.



圖 1/Fig.1



圖 2/Fig.2

### ② 必須接地

接駁地線不牢固，是造成觸電或錯誤動作的原因。

### ② must have ground wire.

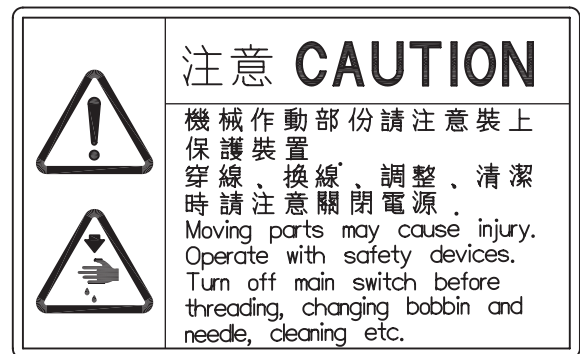
A loosen or a did not connect well ground wire is the reason causing electronic shock or malfunction.

### ③ 表示轉動方向

安全保護裝置(圖3)

- (A) 護指器
- (B) 護目鏡

### ③ 表示轉動方向

Safety Protection Device (Fig. 3)

- (A) Finger protector
- (B) Goggle



圖 3/Fig.3

## 護針安全圖說

## SAFETY ILLUSTRATION OF NEEDLE GUARD

本縫紉機之壓具防護裝置如圖 4 所示，為保護操作者之操作安全，嚴禁將此裝置拆卸。

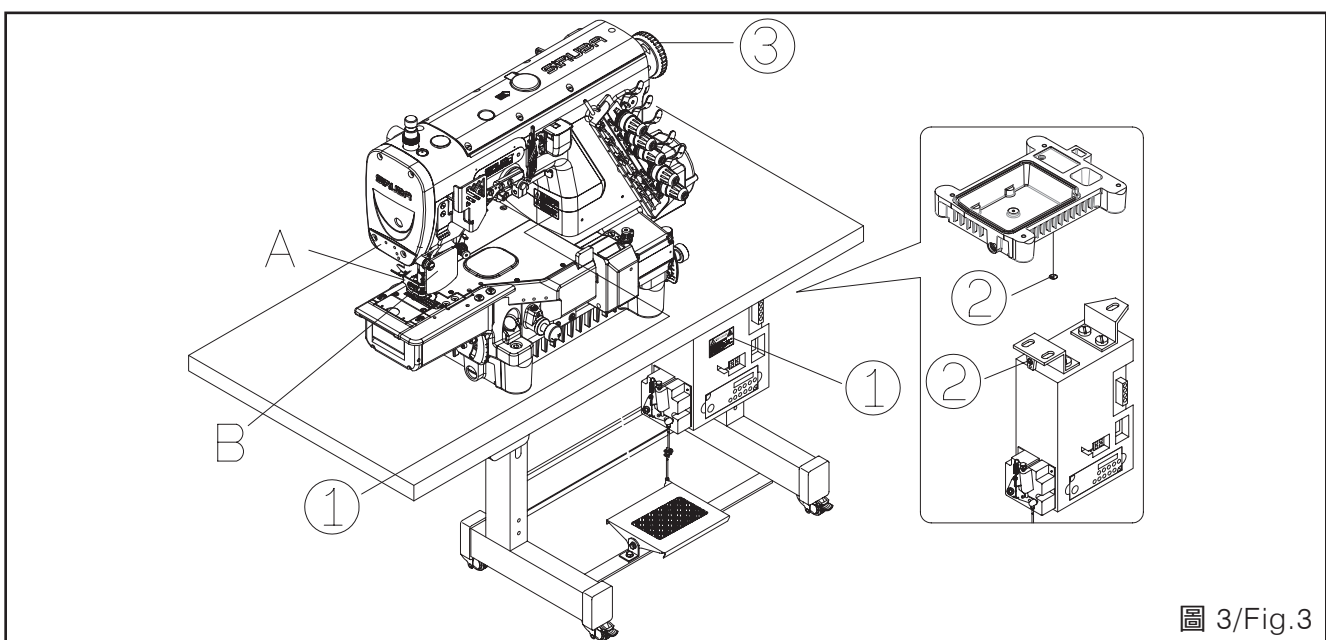
The presser foot protection device is shown as figure 4. For safety of all operators, this device is restricted to disassemble.



圖 4/Fig.4

## 搬運縫紉機

## MOVING THE SEWING MACHINE

1. 請由兩人用手托住機殼本體進行搬運。
2. 用手扶住馬達蓋。
3. 搬運時，請穿著安全鞋。(圖 5)

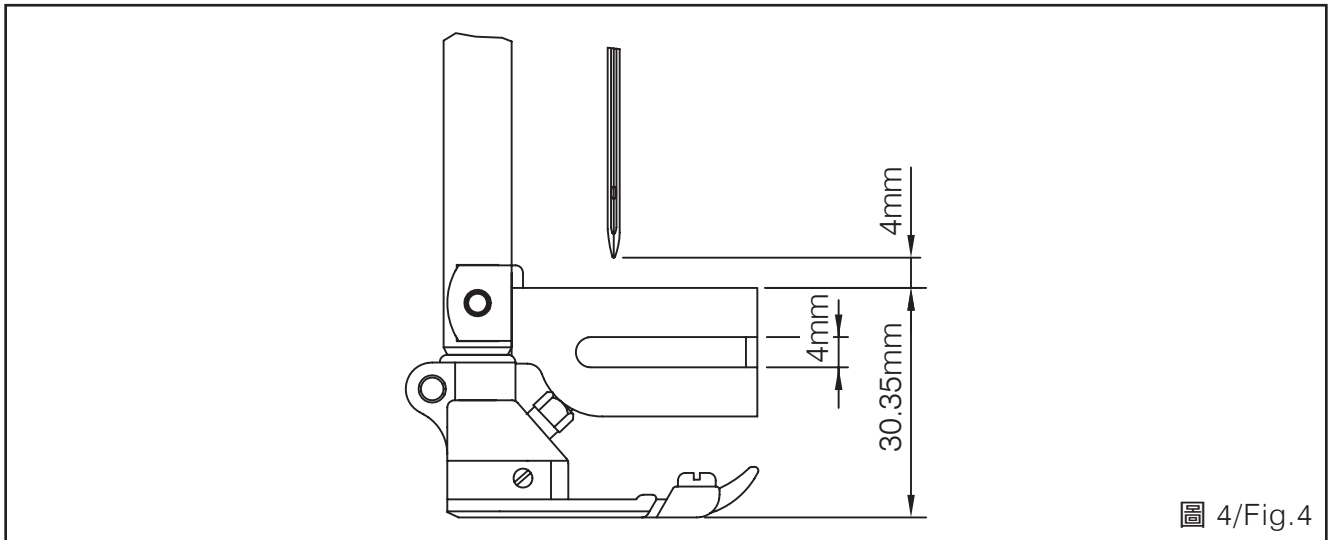
1. The machine should be carried by two people as shown in the figure.
2. Hold the motor cover firmly.
3. Please wear a pair of skidproof shoes while moving the sewing machine. (Fig.5)



圖 5/Fig.5

## 關於縫紉機的安裝位置

## THE INSTALLATION POSITION OF THE SEWING MACHINE

1. 勿將縫紉機置於設備附近，如電視機、收音機或無線電話等，否則這些設備可能被縫紉機的電子干擾所影響。(圖 6)
2. 應將縫紉機直接插入 AC 電源插座，如果使用延長線，可能會造成操作故障。

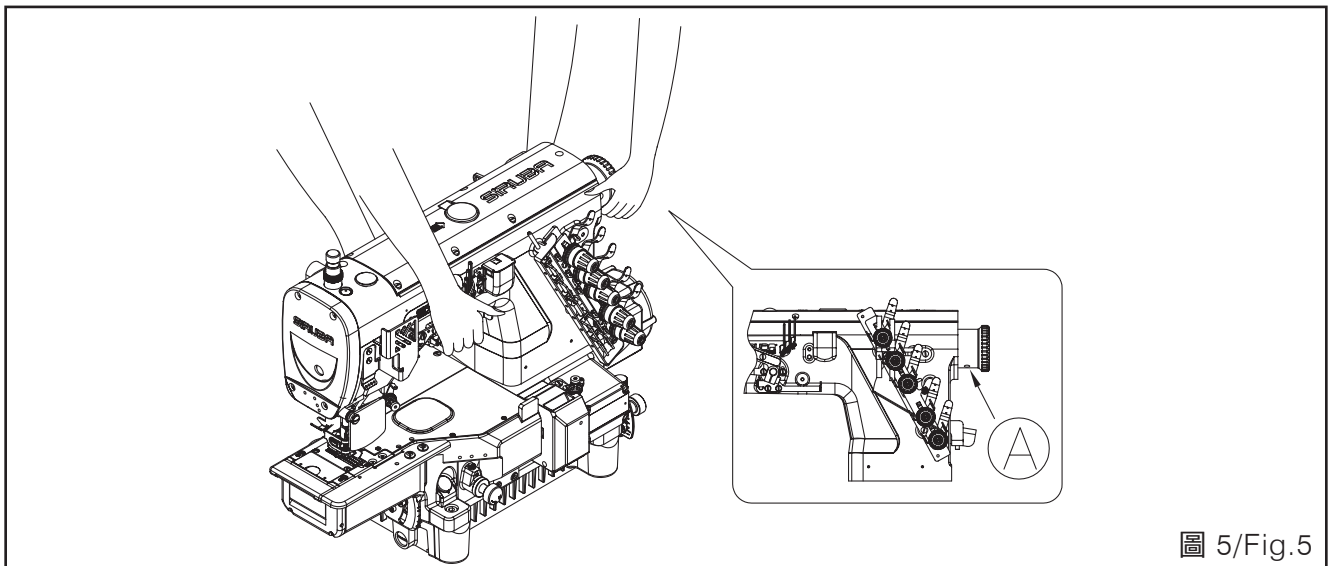
1. Please do not install the sewing machine near the equipments, such as Television, Radio, or wireless Telephone. Or these equipments will experience electronic interference. (Fig.6)
2. The wire should insert to the AC power socket directly. If using the extension wire, this might cause malfunction.



圖 6/ Fig.6

## 規格

## SPECIFICATIONS

1. C007L / C007LX 使用馬達：
    - (1) SIRUBA T41xxx (定位馬達)
    - (2) SIRUBA DCTxxx (伺服馬達)
  2. 使用馬力：1HP (定位馬達) 或 600W (伺服馬達)
  3. 皮帶輪尺寸：直徑 90mm-110mm (出廠設定值為 90mm)
  4. 空壓式：有效空氣壓 3.5kg/cm<sup>2</sup>
  5. 電磁閥電壓 24V 直流
  6. 旋轉式電磁鐵電壓 30V 直流
- 註：
- (1) 馬達使用之電壓、頻率、相數，於訂貨時規定之。
  - (2) 馬達之功能調整請參閱馬達使用說明書。

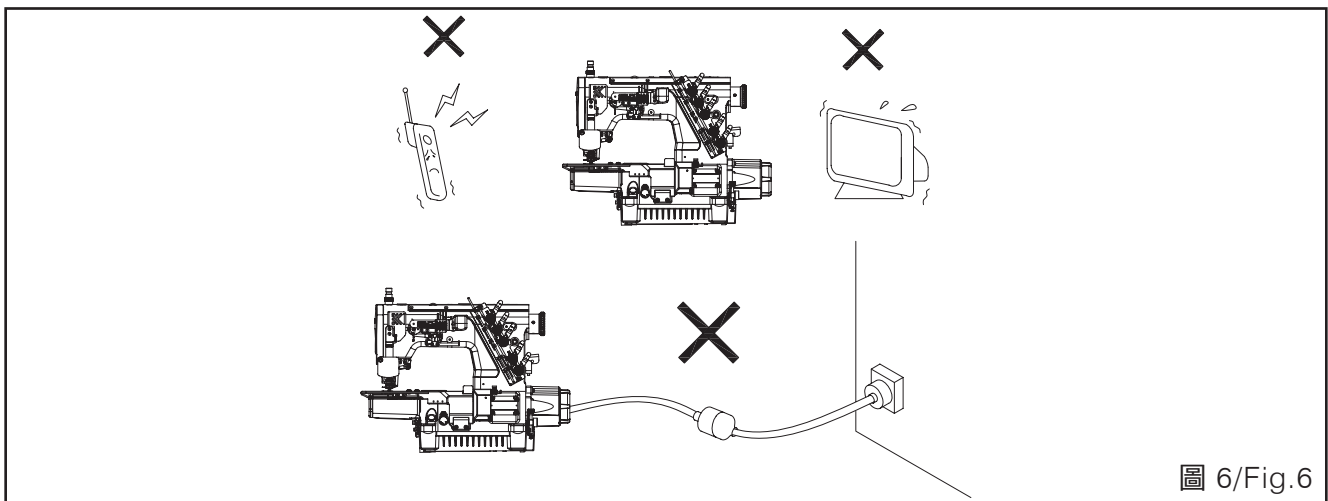
1. C007L / C007LX Motor types：
    - (1) SIRUBA T41xxx (position motor)
    - (2) SIRUBA DCTxxx (servo motor)
  2. Horse power：1HP for position motor/ 600W for servo motor.
  3. Size of motor pulley：90mm-110mm in diameter (standard is 90mm)
  4. Air pressure type：Minimum required pressure is 3.5kg/cm<sup>2</sup>.
  5. The voltage of the solenoid is DC 24V.
  6. The voltage of the rotary electromagnet is DC 30V.
- Note：
- (1) Motor voltage, hertz and phases have to be specified clearly while ordering.
  - (2) All details regarding to the motor adjustment, please refer to the motor operation manual.

## 安全開關及其功能

## SAFETY SWITCH AND ITS FUNCTION

### 1. 氣動式

- 電磁閥(左側)1：為控制壓具抬放動作之驅動。
- 電磁閥(中間)2：為控制針線及下勾針線切刀機構之驅動。
- 電磁閥(右側)3：為控制上裝飾切線切刀機構或空壓吹線吹管之驅動。(以上請參考零件圖)

### 2. 電動式

- 電磁鐵(UT534K)：為控制針線及下勾針線切刀機構驅動。(如零件圖所示)
- 電磁鐵(UT218J)：為控制上裝飾線夾線機構之驅動。(如零件圖所示)
- 電磁鐵(UT776)：為控制上裝飾線切線機構之驅動。(如零件圖所示)

### 3. 安全開關為感測針線及下勾針線切線機構，於切線後是否回歸原點，切線機構如未在原點時，馬達將無法運轉(圖7)。

#### 注意：

- (1)在連接電磁閥線路時，請確記先關掉電源開關，若電源開關未關閉時，請注意勿使紅色及黑色兩線因互相接觸造成短路以致損壞內部電路(如零件圖所示)。
- (2)與馬達控制箱連接之插頭，應充分插入，使接觸良好；避免鬆動而產生動作不良或無動作。

### 1. Pneumatic

- Solenoid valve (left side)1: is used to control the presser foot lift and lower movement.
- Solenoid valve (middle)2: is used to control the operation of the lower trimmer. (Including needle thread and lower looper thread.)
- Solenoid valve (right side)3: is used to control the operation of the spreader's thread trimmer or to drive the air blower. (Please refer to the parts list for above information.)

### 2. Electric

- Electromagnet (UT534K): is to control the operation of threads (upper and lower) and the mechanism of thread trimming (as shown in the parts list).
- Electromagnet (UT218J): is used to control the operation of the top cover thread pulling system (as shown in the parts list).
- Electromagnet (UT776): is used to control the operation of top cover thread trimmer (as shown in the parts list).

### 3. The major function of the safety switch is to check and confirm the thread trimmer of needle's and lower looper's returning to the origin. If the trimmer is not located on the origin, the motor will not function at all. (Fig.7)

#### Note:

- (1) Please be sure to turn off the power switch before connecting the wires on the solenoid valve. If the power switch is not turned off, please notice that the red and black wires do not contact. Otherwise, the contact will cause short circuit and damage the internal circuit (as shown in the parts list).
- (2) The plug connecting with the motor controlling box should be plugged fully so that it contacts well. This will prevent the malfunction resulting from the loose plug.



圖 7/ Fig.7

### C007L/C007LX 一般車 定位器之安裝與調整

1. 將隱藏式定位器①壓入車頭長溝②後，再以螺絲③鎖緊。(圖 8)
2. 在連接各部接線或接頭時應注意先關閉電源開關。
3. 確認針棒在上定位時，車頭上之記號①應與手輪②上所標示的刻劃③上方一小刻劃對齊。(圖 9)

### C007L/C007LX INSTALLATION AND ADJUSTMENT OF SYNCHRONIZER

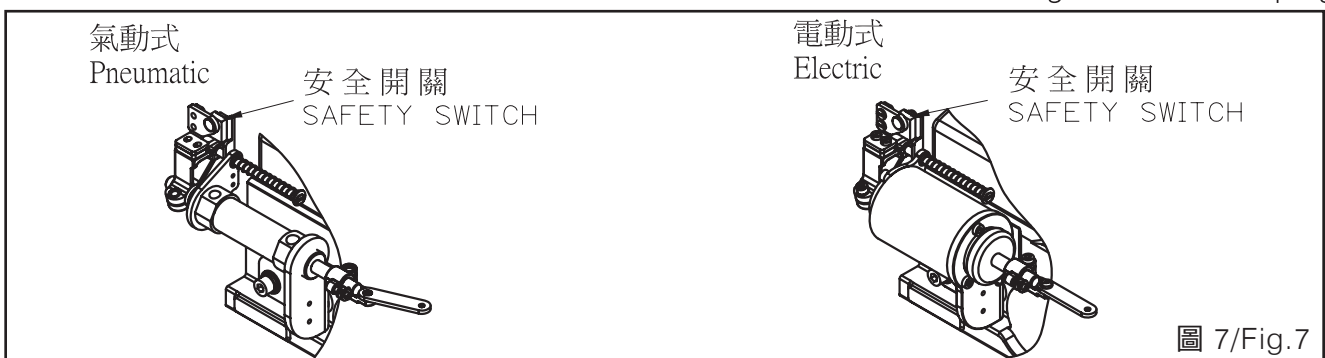
1. Press the hidden synchronizer ① into the long channel of the machine head ②, and then tighten the screw ③. (Fig. 8)
2. Before connecting each wires or plugs, please check that all the electric switches are turned off.
3. Ensure needle bar is at the highest position, and the symbol on machine head should be aligned with one upper scale at the hand pulley. (Fig. 9)



圖 8/ Fig. 8



圖 9/ Fig. 9

## 操作步驟

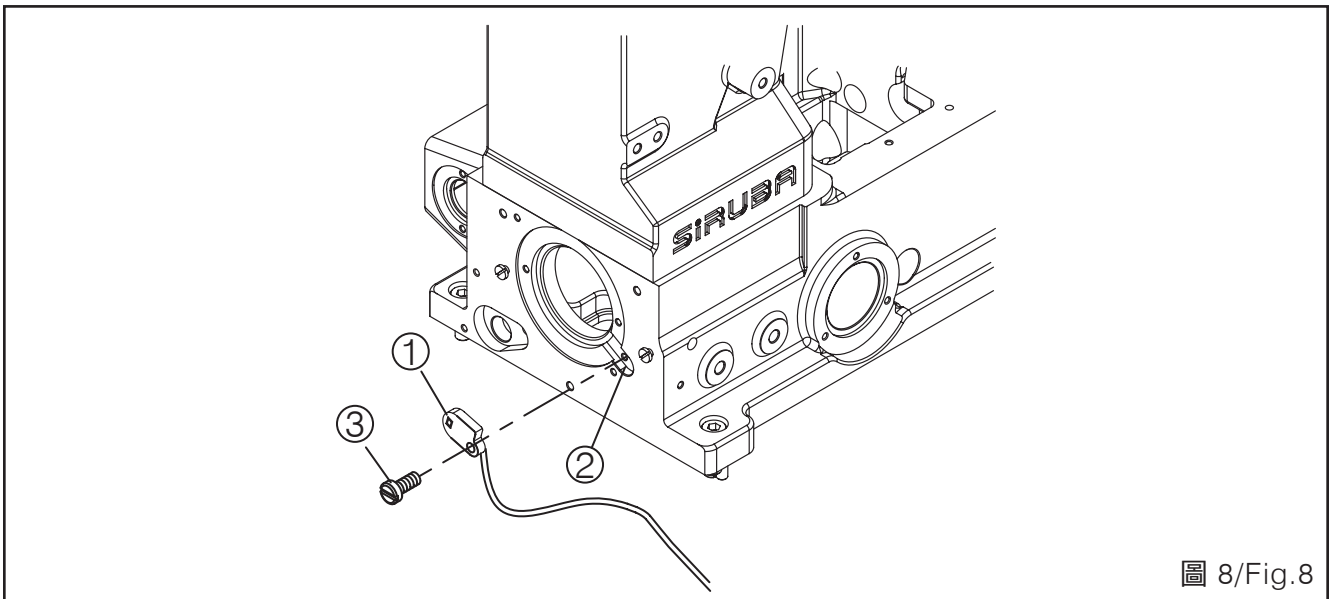
## OPERATION PROCESS

1. 當腳往前踩下腳踏板，機器開始運轉和車縫。(圖 10)-1
2. 當腳踏板置於(圖 10)-2 位置時，機器停止運轉且針棒落於最低位置。
3. 當後踩踏板(圖 10)-4 時，針棒轉至最高點停住，各切線機構開始操作。
  - (1) 針線及下勾針線切線機構將針線及下勾針線拉至上刀切斷，切斷之勾針線由夾線機構夾持。
  - (2) UTP-L 及 UTR-L 時，上飾線機構將上飾線切斷並將線頭拉至彈片處夾持。
  - (3) UTQ-L 時，針線以空氣壓力將針線吹至壓具上方。
  - (4) UTS-L 時，針線拉線機構將針線拉至彈片夾持。
  - (5) 壓具提升。
4. 移開車縫布料進行下一次縫紉。
5. 將腳踏板放回至(圖 10)-2 位置壓具即放下。
6. 將腳踏板置於(圖 10)-3 或(圖 10)-4 位置可使壓具提升。

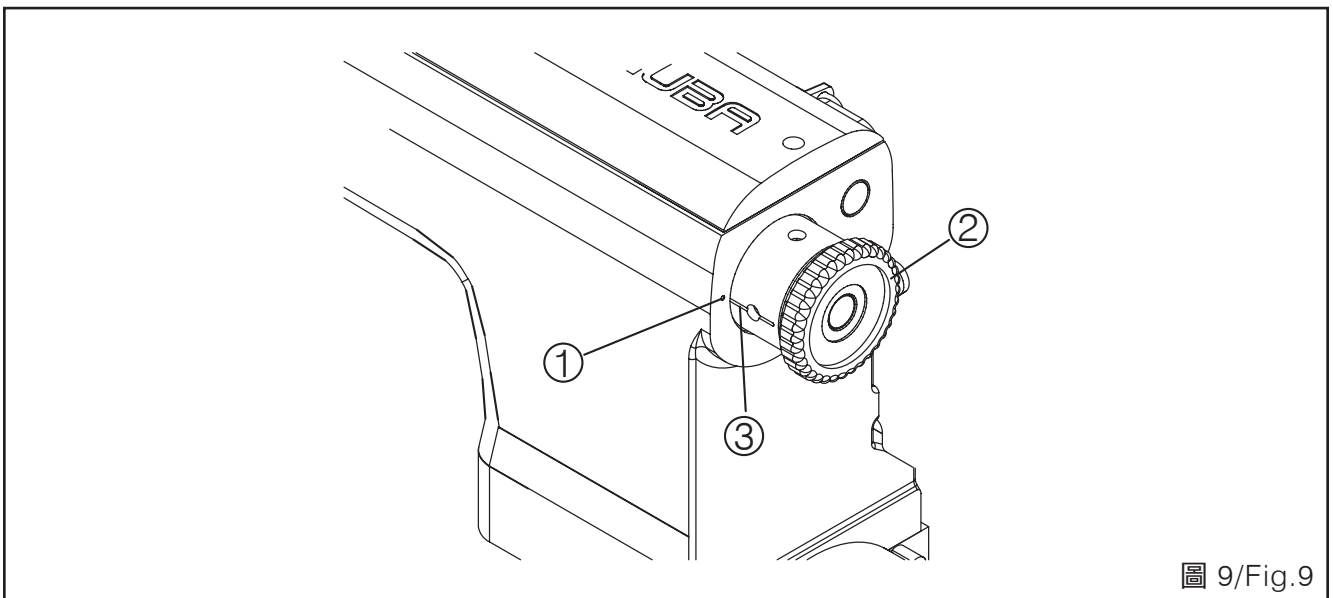
注意：

- (1) 在無空壓源之狀態時，請勿將下切刀置於左側切線之位置，以免誤動機器電源開關，將下切刀碰壞。

1. Thread on the pedal to start the machine and sewing. (Fig.10-1)
2. When the pedal stop horizontally (Fig. 10-2), the machine stops running and the needle bar will stop at the lower dead point.
3. When threading the pedal backward and holding (Fig.10-4), the needle bar moves up and stops at the upper dead point, and all trimming system start working.
  - (1) When the mechanism of the thread and lower thread trimmer pull the thread and the lower thread to top trimmer to trim, the trimmed thread will be held by the clamping mechanism.
  - (2) When under UTP-L and UTR-L, top cover thread trimming mechanism trims and clamps the top cover thread.
  - (3) When under UTQ-L, needle's thread will be blown to the upside of the presser foot by air pressure.
  - (4) When under UTS-L, needle's thread will be pulled and clamped by needle's thread pulling mechanism.
  - (5) Presser foot lifter.
4. Remove the material away for the next sewing.
5. Keep the pedal in horizontal position as shown as (Fig. 10-2), the presser foot will put down.
6. Thread the pedal at the backward position of (Fig. 10-3) or (Fig. 10-4) so that the presser foot may lift.

Note:

- (1) Do not put the lower trimmer to the left thread trimming location when there is no air pressure source in order to prevent damaging the lower trimmer from turning the power switch on.

- (2) 電磁式 (UTR-L 、 UTS-L) 在無通電之狀態時，請勿將下切刀置於左側切線之位置，以免誤動機器電源開關，將下切刀碰撞。
- (3) 壓具下方未放置車縫布料時，請勿操作自動切線機構。

- (2) Do not put the lower trimmer to the left thread trimming location when the electromagnet types (UTR-L , UTS-L) are disconnected lest the power switch should be turned on and the lower trimmer should be damaged.
- (3) When there is no fabric under the presser foot, do not operate the auto trimming system.

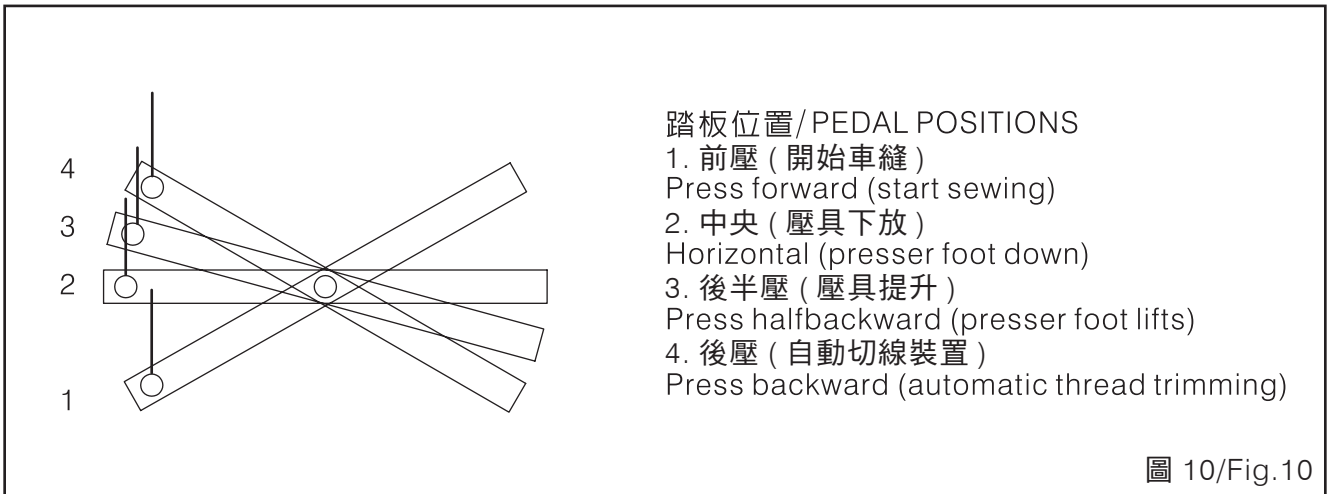

## 各部件名稱

## NAMES OF MAJOR PARTS

- |             |                                  |
|-------------|----------------------------------|
| (1) 過線盒     | (1) Thread Guide Box             |
| (2) 導線片     | (2) Thread Guide                 |
| (3) 壓具      | (3) Presser Foot                 |
| (4) 控制箱     | (4) Control Box                  |
| (5) 油鏡      | (5) Oil Windows                  |
| (6) 拉線鬆緊調整組 | (6) Thread Tension Adjusting Set |
| (7) 手輪      | (7) Pulley                       |
| (8) 線架      | (8) Thread Stand                 |
| (9) 壓具調整螺絲  | (9) Presser Foot Adjusting Screw |
| (10) 護指器    | (10) Finger Guard                |



圖 11/ Fig.11

## 機種說明

## THE DESCRIPTION OF THE MODEL

種類及規格說明

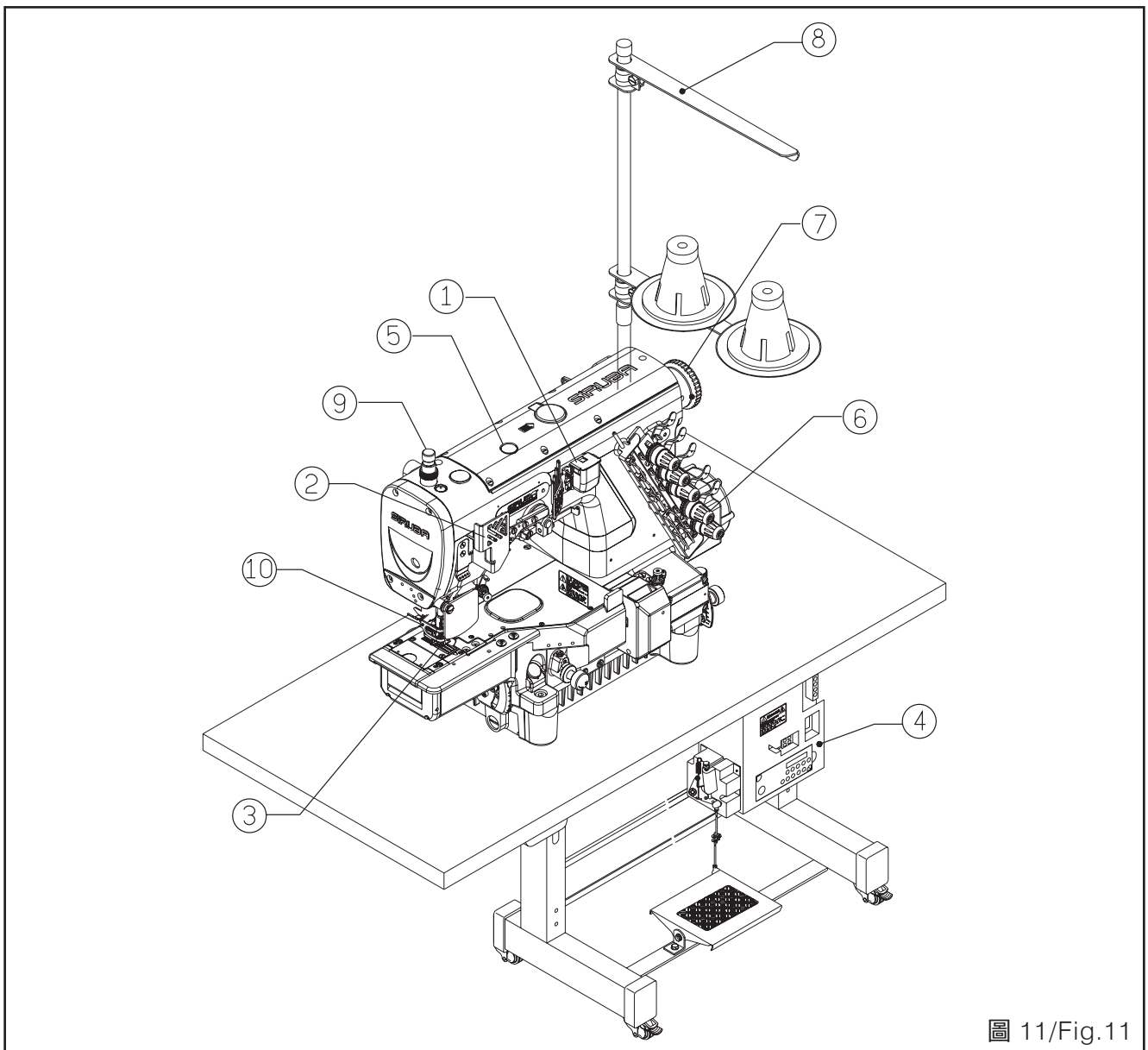
1. 型號及分類表示

Specifications of machine category

1. Description of the machine name

C 0 0 7 L X - W 1 2 2 - 2 4 0 / C H  
 |        | |        |    √ |        |    √        |    √  
 ①        ② ③        ④ ⑤ ⑥        ⑦ ⑧        ⑨

①表示機種別：  
C = 筒式三針車。

②表示車台外觀改良之區分編碼，由 K 然後 L，以英文字母排列，如 C007L。

③表示微油車。

④ W 有上叉縫 (圖 12)。  
U 無上叉縫 (圖 13)。

① represents the type of the machine:  
C = Three needles cylinder bed  
chainstitch machine

② represents the improved machine  
appearances that are arranged from  
letter K. Ex: C007L.

③ represents Semi-Dry.

④ W = have upper cross stitchery (Fig.12)  
U = Without upper cross stitchery (Fig.13)



圖 12/ Fig.12



圖 13/ Fig.13

⑤ 車縫形式：

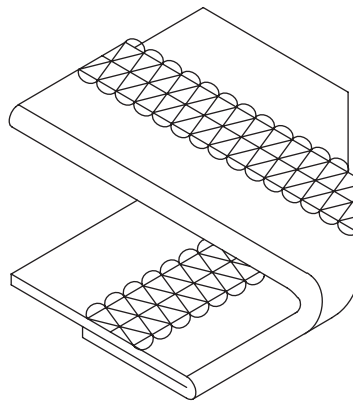
- 12= 一般車縫
- 13= 拷下襞
- 15= 三角褲、緊身褲、內褲等棉織物  
伸縮帶上帶縫

16= 一般厚布料之車縫

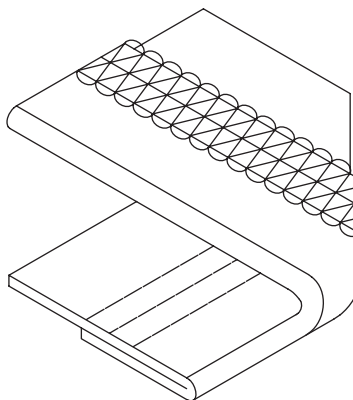
- 22= 附車縫包條作業
- 32= 包飾縫作業
- 51= 上送式鬆緊帶上帶車縫

- 52= 上花邊鬆緊帶
- 53= 環型平織鬆緊帶上帶車縫

54= 下送式鬆緊帶上帶車縫

- 61= 單面飾縫褲耳
- 71= 雙鍊縫
- 72= 褲帶縫作業
- 81= 拷下擺附左切刀
- 82= 鬆緊帶上帶邊縫附左切刀

92= 三針車四針車縫

⑥ 表示針板舌片之形狀(針板舌的功能：

打網)(圖9)

- 1 為薄布用
- 2 為中厚布用
- 3 為厚布用

⑤ is stitching type:

- 12= general seaming
- 13= bottom hemming
- 15= elastic tape feeding for cotton fabric  
such as underwear, and tights pants

16= general seaming for normal thick  
materials

- 22= tape binding
- 32= seam covering (decorative stitching)
- 51= elastic tape feeding, upper feeding  
type

- 52= elastic or lace seaming
- 53= elastic tape feed seaming in hooped  
type lockstitch

54= elastic tape feeding, lower feeding  
type

- 61= belt loop seaming
- 71= double chain stitch
- 72= pocket lining seaming
- 81= bottom hemming with left trimmer
- 82= elastic tape feeding with left trimmer
- 92= four needles chain seaming

⑥ means the shape of the needle plate  
tongue, which its function is to knot.  
(Fig. 9)

- 1 = for thick/heavy materials
- 2 = for midium- thick materials
- 3 = for thin/light materials



圖 14/Fig.14

⑦表示縫針線數(圖 15)  
2為2針車  
3為3針車  
4為4針車

⑦ is the number of stitches. (Fig.15)  
2= 2 needles sewing machine  
3= 3 needles sewing machine  
4= 4 needles sewing machine

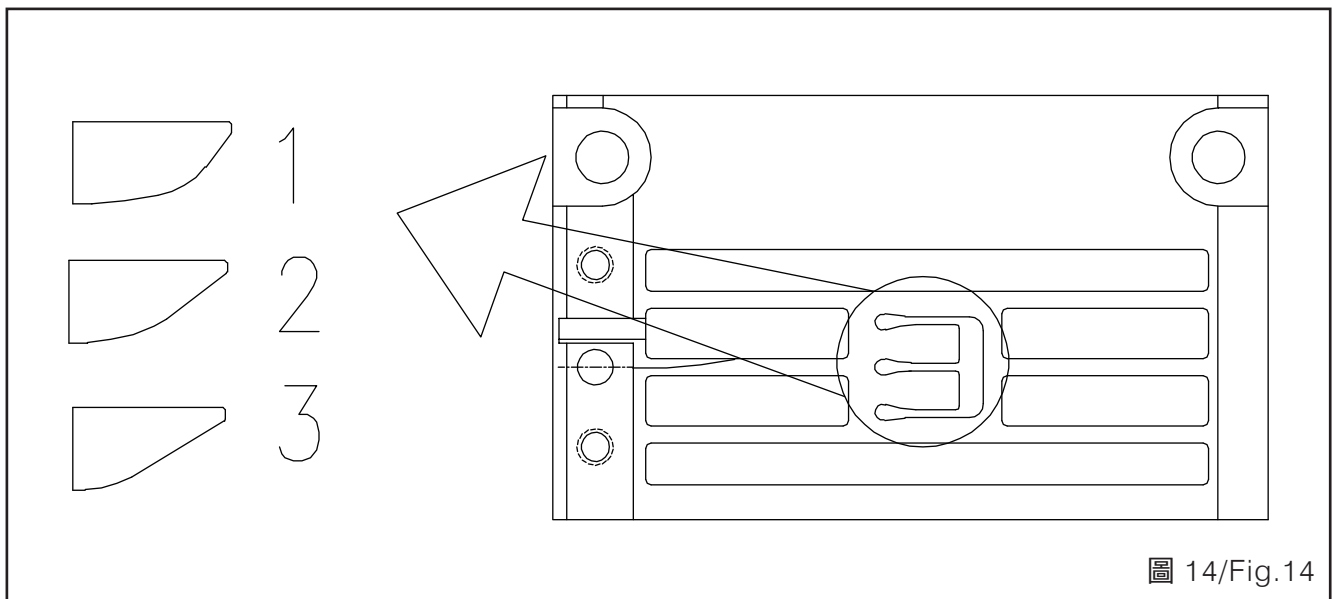

圖 15/ Fig.15

⑧針寬(左右縫線針之距離)(圖 16)

3.2mm , 4.0mm  
4.8mm , 5.6mm  
6.4mm

⑧ means the needle width (the distance between the left and the right stitch. (Fig.16)

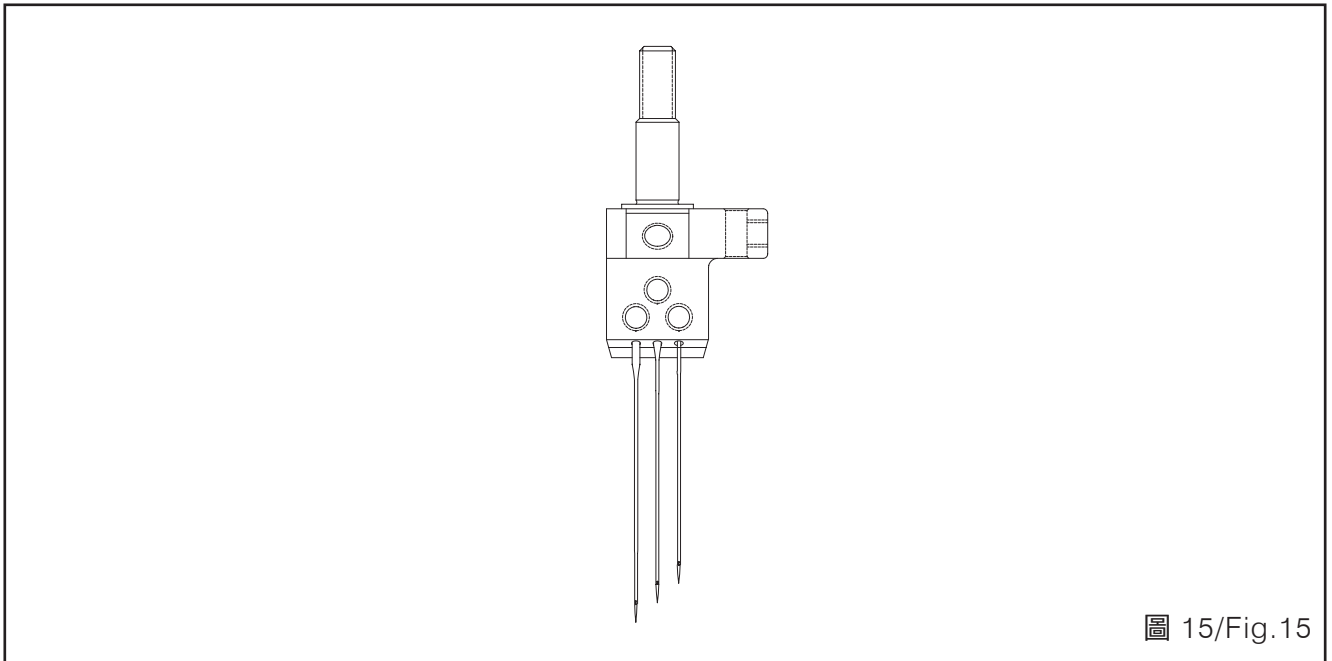
3.2mm , 4.0mm  
4.8mm , 5.6mm  
6.4mm



圖 16/ Fig.16

⑨輔助機型：如CH、CQ、CZ...等等

⑨ is supportive models, such as CH, CQ, CZ, etc.

## 2. 用途項目 (表一)

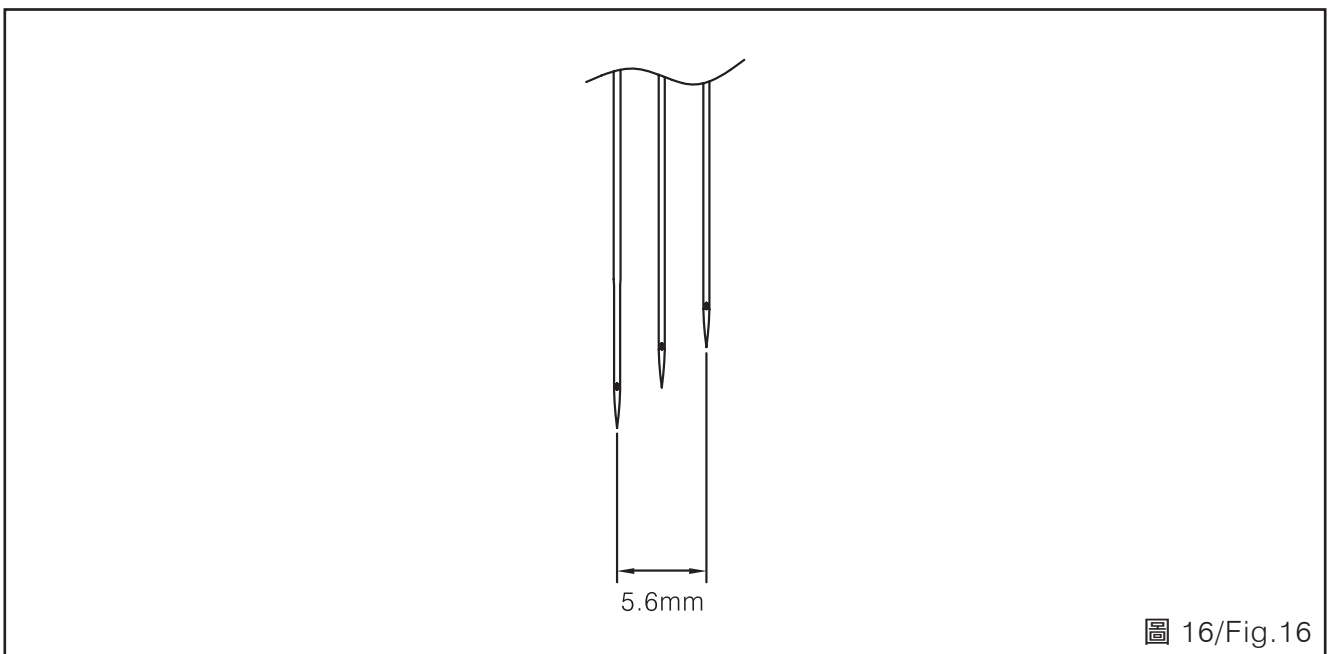
## 2.Purpose (Table 1)

編號 Code	用途 Application	車縫最高轉速 R.P.M Highest sewing rotational speed		縫距 (mm) Max. Stitch length
		C007L	C007LX	
L	用於薄布料 For light-weight materials	6000	4500	1.4~3.6
M	用於中厚布料 For medium-weight materials	6000	4500	1.4~3.6
H	用於厚布料 For heavy-weight materials	5000	4000	1.4~3.6

表 1/Table 1

## 3. 規格

## 3.Specification

機型別 Model	C007L/C007LX		
規格 Specification			
車縫布料 Sewing materials	薄布料 Light material	中厚布料 Medium weight material	厚布料 Heavy weight material
車縫最高轉速 (R.P.M) Max. sewing rotational speed	6000/4500	6000/4500	5000/4000
噪音 Noise	82dB/4500R.P.M		
最大縫距 Max. Stitch Length	3.6mm		
針棒行程 Needle bar stroke	31mm	33mm	35mm
使用針 Needle DB×1-DP×5	SCHMETZ UY128GAS#70 ORGAN UY128GAS #10		
壓具壓力 Presser foot pressure	4-5 KGF	5-7 KGF	
壓具提升量 Presser foot height	6mm		
壓具 Presser foot	可調整性壓具 Adjustable presser foot		
送料具高度 Feed dog height	0.8mm	1mm	1.2mm
重量 Weight	機頭 Head: 45kg 控制箱 Control box: 3kg		
機頭空間尺寸 Machine head	長 Long 550mm× 高 Height 400mm		
桌板尺寸 Table specification	605mm×1200mm		605mm×1070mm
加油方式 Lubrication	完全自動加油 Automatic lubrication system		
潤滑油 Oil	提供之專用油 SIRUBA sewing machine oil		
機頭驅動 Machine head driving	直接驅動裝置 Directly driving device.		
馬達 Motor	最大輸出 600W Max. Output 600W		
控制電路 Control circuit	單相 Single-phase 220V±15%		
使用電路 Power	單相 Single-phase 220V±15%		
電磁線圈驅動電源 Solenoid driving power	氣動：24V 電動：30V		

表 2/Table 2

## 關於本機的重要安全注意事項

## IMPORTANT SAFETY INSTRUCTIONS OF THIS MACHINE

### 1. 搬運作業

(1) 使用上下二片式的保麗龍將機器包裝防護。

(2) 放入紙箱內。

(3) 用手推車或二人用雙手抬動搬運。

### 2. 儲存作業

(1) 機器不使用時，應用防塵套將其罩上。

(2) 避免儲存於高於 45°C 以上的高溫。

### 3. 作業中

機器不要在高於 40°C 以上的溫度工作。

### 4. 警告

請注意以下警示建議事項。

(1) 工作區域是危險的。

(2) 當機器還在運作的時候，絕對不要去碰觸針。

(3) 當在送布料的時候要多加小心。

(4) 不要把手指放在針與傳送布料的轉具之間。

在貼有警告標示之處請注意。

(1) 機械動作部分，請注意裝上保護裝置。

(2) 穿線、換線、調整、清潔時，請注意關閉電源。

### 1. Transportation

(1) The machine packed with two piece - up and lower - covers that made of expanded Polystyrene to protect it.

(2) Put the machine into a carton.

(3) Use a cart or by two men's hands to move it.

### 2. Storage

(1) The machine must use duster cover to cover it when it did not work.

(2) Do not storage the machine over 45 °C .

### 3. Working

The machine doesn't work over 40 °C .

### 4. Warning

Pay attention to the following warning advices:

(1) Working area is dangerous.

(2) Never touch the needle if the machine is still running.

(3) Be careful if you infeed fabric.

(4) Do not insert your finger between needle and roller for transportation on fabric.

Pay attention to the warning sticker.

(1) Movable parts must be enclosed with guard when you operate.

(2) Turn off the power during adjusting, threading, bobbin-changing and needle-cleaning.

## C007L/C007LX 直驅車 馬達安裝方式

## C007L/C007LX INSTALL THE MOTOR

### 安裝步驟：

1. 首先將連軸器 (A) 依順時針方向的第一顆螺絲 (1)，固鎖於大心軸 (B) 上之長槽孔 (3)，接著再鎖緊螺絲 (2)。
2. 將橡膠緩衝墊 (C)，以單面有 2 凸台記號 (4) 那端，對準連軸器 (A) 上之圓槽 (5) 後壓緊。
3. 將馬達 (D) 上之內槽扣孔與橡膠緩衝墊 (C) 上之凸台 (7) 互相扣接壓緊結合。
4. 將馬達 (D) 以螺絲 (8) 與墊片 (9) 鎖固於機體上。

### 注意事項：

若馬達與連軸器未依上述位置正確組裝，將會導致針棒停針的位置點不對；馬達組裝正確情形下，當針棒置於上死點時，針棒的左針與針板面距離約 7.8mm。

### INSTALLATION PROCEDURE:

1. Attach coupling (A) to lower main shaft (B) by fitting the first setscrew (1) to the long groove (3) of shaft, then tighten it and the other setscrew (2).
2. Attach rubber cushion (C) with the side of two projections (4) to coupling (A) by fitting projections to notches (5).
3. Attach motor (D) to rubber cushion (C) by fitting the inside projections to notches (7) on rubber cushion.
4. Use screws (8) and washers (9) to tighten motor (D) on machine body.

### CAUTION:

Check to be sure that the “motor and coupling are installed correctly” as so to prevent needle bar from stopping on wrong position. If motor is installed correctly, the distance between the left needle on needle bar and needle plate will be 7.8mm when needle bar is in its highest dead point.



圖 19/ Fig.19

## 穿線方法

請確實按照圖示各種不同縫合情況穿線，錯誤之穿線將引起斷線、跳針及車縫不平坦等現象，請參照穿線圖。

- \* 薄布料請參考 (圖 20)
- \* 中厚布料請參考 (圖 21)

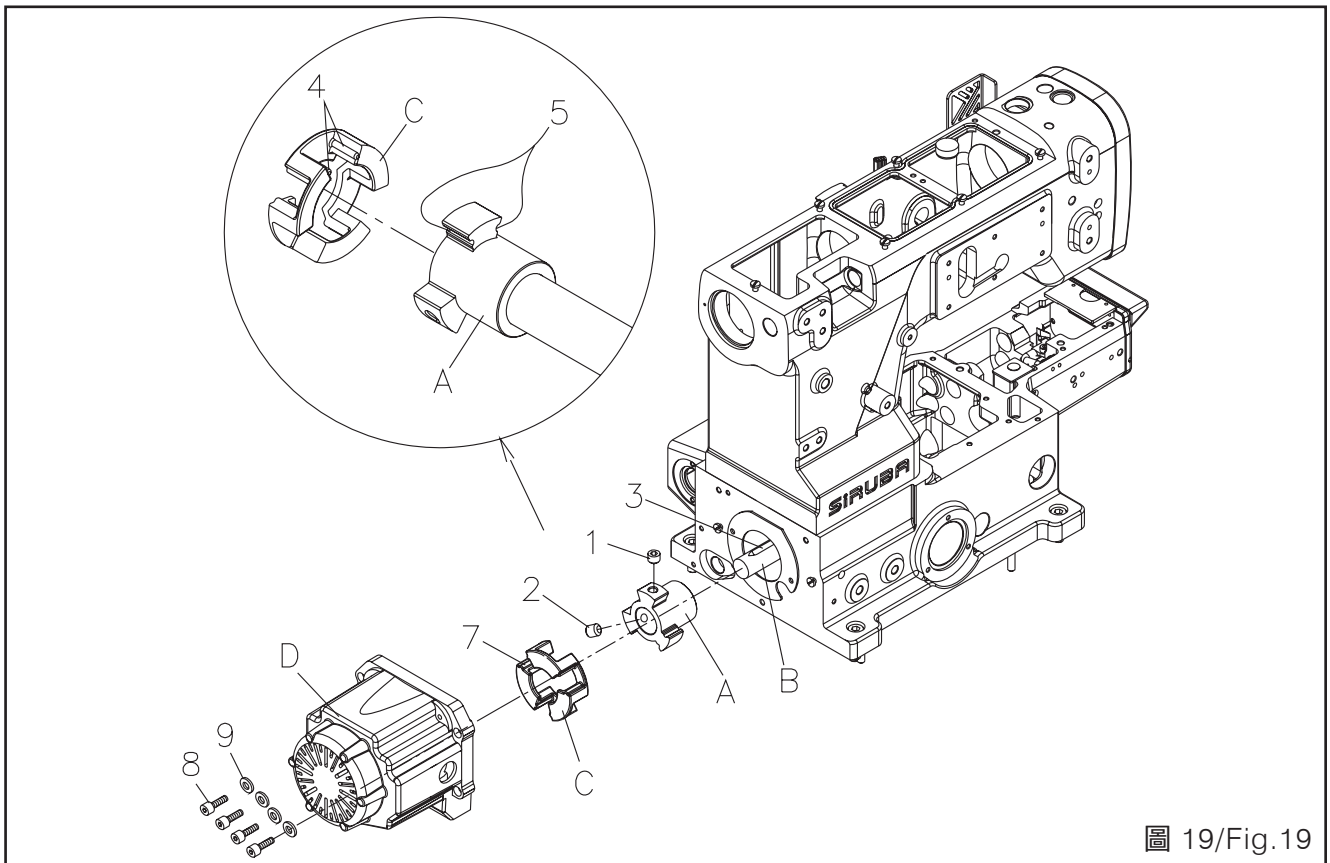

圖 20/21

## THREADING

Please thread truly by different seam types. The fault threading will cause broken lines, skipping stitch, puckering defects. Please refer to threading instructions.

- \*Fine fabrics are followed to Fig.20
- \*Medium and heavy fabrics are followed to Fig.21.

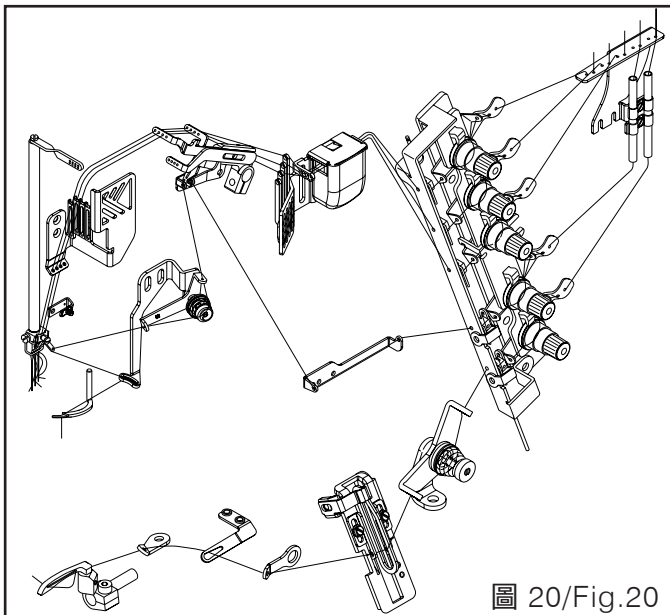

圖 21/20

## 拉線鬆緊度調整

拉線強弱必須根據：

1. 車縫布料種類
2. 材質厚薄
3. 線
4. 縫距

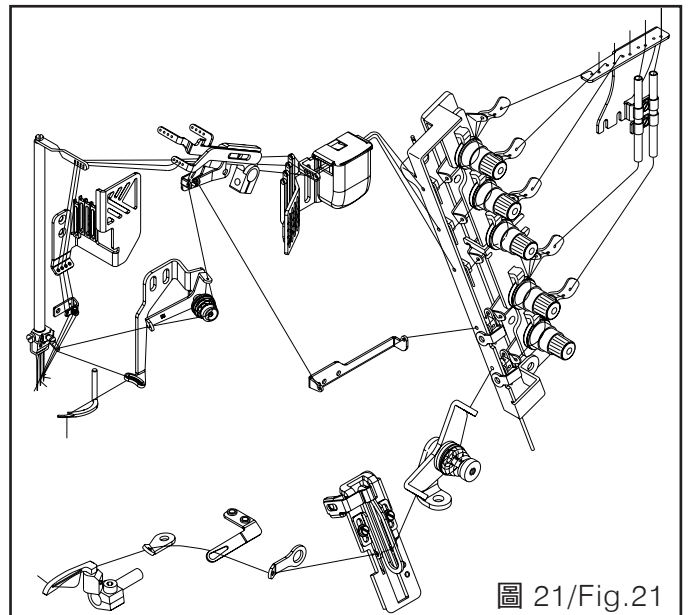
等不同而做調整，將控制鈕順時鐘方向旋轉時，線越緊，反之則越鬆。(圖 20、21)

## ADJUST THREAD TENSION

The tension of the thread should be adjusted according to :

- 1.The fabric material type
- 2.The thickness of the sewed fabric
- 3.The thread;
- 4.The stitch length.

Turn the tension button clockwise, and thread becomes tighter. If you turn it counter-clockwise, it becomes looser.(Fig .20.21)

## 針線挑線桿之調整

## ADJUSTING NEEDLE THREAD TAKE-UP

1. 轉動手輪使針棒位於最低位置時，針線控桿搖臂①的上邊必須成水平，必要時放鬆螺絲④調整之。（圖 22）

1. When turning the pulley and make the needle bar in the lowest position, the top edge of the needle thread take-up ① should remain horizontal. To adjust the position of the take-up if necessary, loosen the screw ④ (Fig.22)

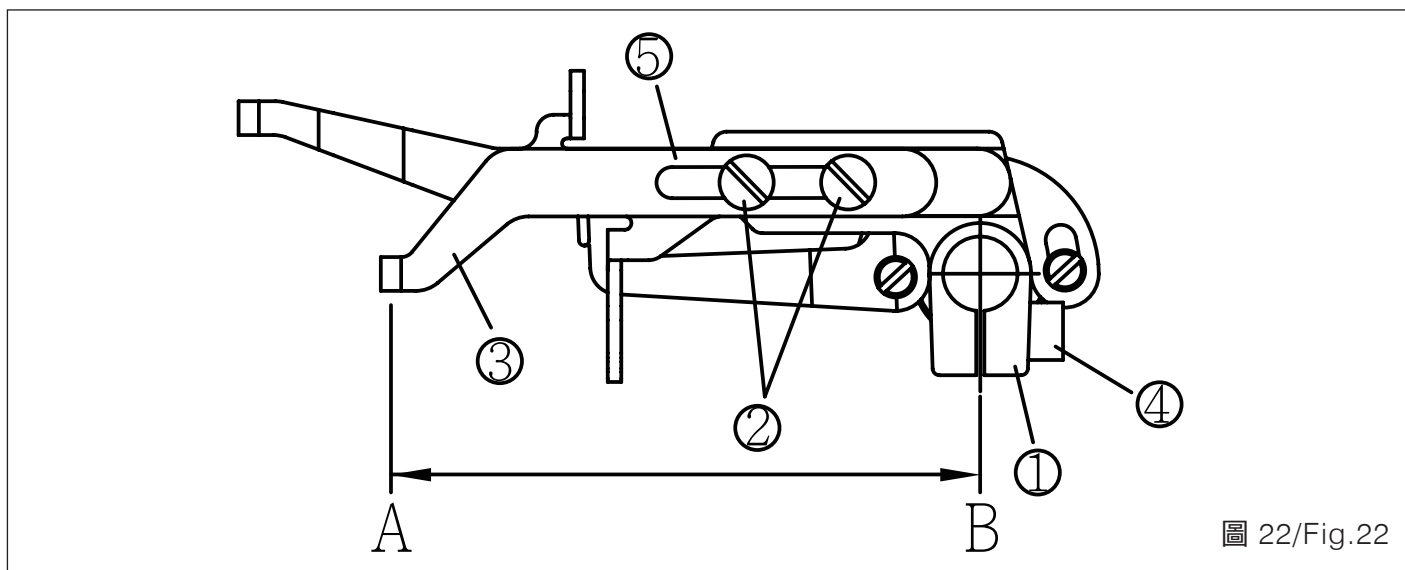

2. 將螺絲②鬆開，調整 A ， B 兩點的距離約 75 mm 再鎖緊。

2. Loosen screw ② to adjust the length between point A and B to be about 75 mm, then fasten it tightly.

註：

欲將針線調鬆時，將挑線桿③向左方向移動。  
欲將針線調緊時，將挑線桿③向右方向移動。

Note:

To loosen the needle thread, turn the needle thread take up ③ toward the left. To tighten the needle thread, turn the needle thread take up ③ toward the right.

3. 上叉挑線桿⑤不要調動。

3. Do not move the spreader thread take-up ⑤ when making above adjustments.

## 壓具之調整

鬆開螺絲①，左右搖擺，調整壓具②，使針尖端剛好位於如圖示之中心點，調整後，再鎖緊螺絲①。（圖 23）

## ADJUSTING PRESSER FOOT

Loosen screw ① and adjust presser foot ② left and right to a proper position to let the needle may get into the center of presser foot's eyelet. After adjusting, tighten screw ① . (Fig.23)

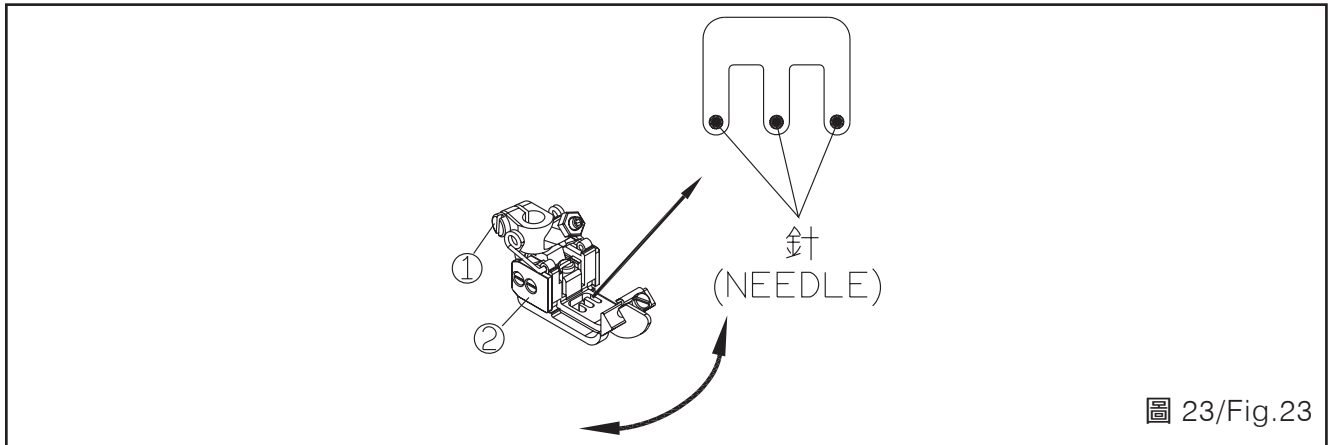

## 差動比調整 1 : 0.6 ~ 1 : 1.1

差動比 = 後送齒送具行程 : 前送齒送具行程

1. 本機之差動比可從 1:0.6 調整至 1:1.1。

註：

若需調整至 1:1.1 以上，請見下頁說明。

2. 用手調整旋轉旋鈕 ② 即可調整前送齒送具行程，調整範圍 1:0.6~1:1.1mm。(圖 24)
3. 用手調整旋轉旋鈕 ②，可立即由刻度版 ③ 內之指針對應右側刻痕及數字觀看得知目前的前送齒送具行程。
4. 伸縮布料車縫時，將旋鈕 ② 以順時針方向旋轉。
5. 皺縮布料車縫時，將旋鈕 ② 以逆時針方向旋轉。

## ADJUSTING DIFFERENTIAL RATIO 1 : 0.6 ~ 1 : 1.1

The differential ratio = rear feed dog stroke : front feed dog stroke

1. The differential ratio can be adjusted from 1:0.6 TO 1:1.1.

Note:

If the adjustment range of differential ratio greater than 1:1.1mm is needed, please go on to next page for further details.

2. Adjust the rotary knob ② by hand to adjust the front feed dog stroke. The adjustable range is 1:0.6~1:1.1mm. (Fig. 24)
3. After manual adjusting the rotary knob ②, the feed dog stroke can be known by the indicated number on the scale plate ③.
4. Turn the knob ② clockwise when sewing the elastic fabric.
5. Turning the knob ② counterclockwise when sewing the shrink fabric.



圖 24/ Fig.24

## 差動比調整 1 : 0.9 ~ 1 : 1.4

## ADJUSTING DIFFERENTIAL RATIO 1 : 0.9 ~ 1 : 1.4

1. 本機之差動比可從 1:0.9 調整至 1:1.4。  
(圖 25)
2. 鬆開側蓋①的三顆螺絲並取下側蓋。  
(圖 26)
3. 鬆開差動連桿②上之螺絲③。(圖 27)
4. 校正差動連桿②中之上螺絲③的位置，螺絲須對齊至孔④之處，並鎖緊螺絲。  
(圖 27)

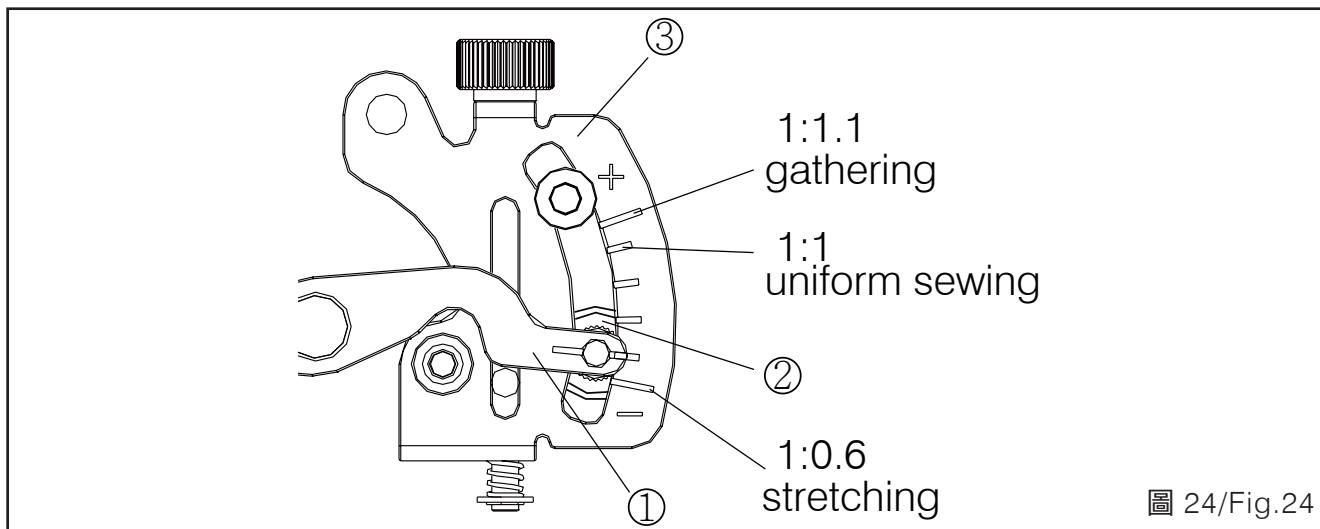
注意：

若差動比要調整至 1:1.4~1:1.8，縫距必須在 2.5mm 以下，超過範圍將會造成機器損壞。

- 1.The differential ratio can be adjusted from 1:0.9 To 1:1.4.(Fig.25)
- 2.Remove the side cover ① (three pcs. of screws).(Fig.26)
- 3.Remove the screw ③ of the differential feed bar connection ② .(Fig.27)
- 4.Fix the differential feed bar connection ② in the hole ④ with the screw ③ .(Fig.27)

Precaution:

If the differential ratio has the range set from 1:1.4 to 1:1.8, the stitch length must be under 2.5mm. Otherwise, it can result in damage to the machine.



圖 25/ Fig.25



圖 26/ Fig.26

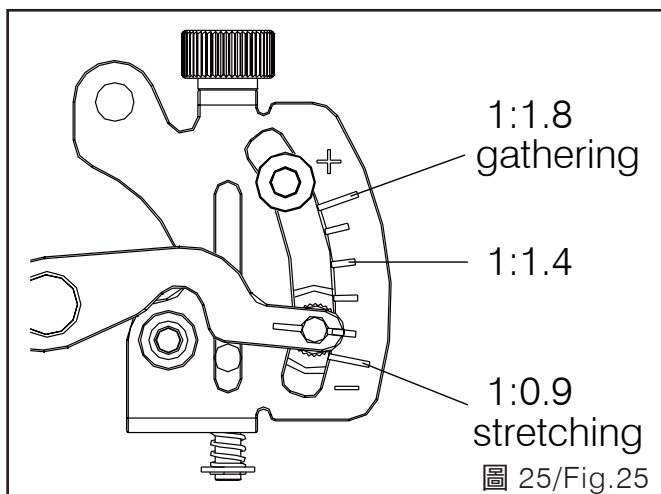

圖 27/Fig.27

### 差動送布牙的調節

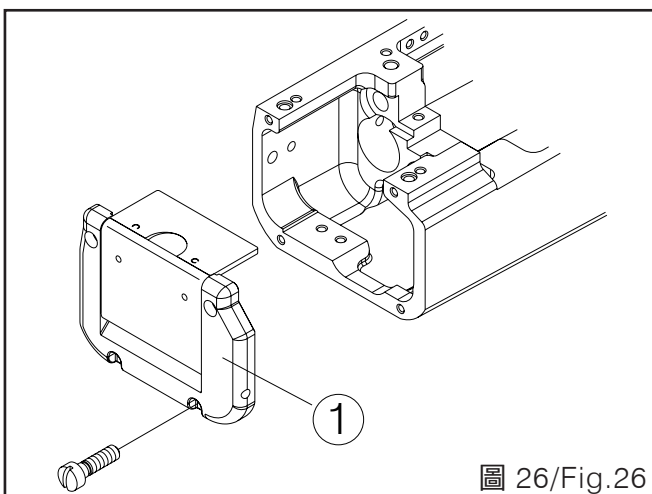
### ADJUSTING MOVEMENT OF DIFFERENTIAL FEED DOG

產品出廠時，差動比預設的可調節範圍為 1:0.7 到 1:1.4。

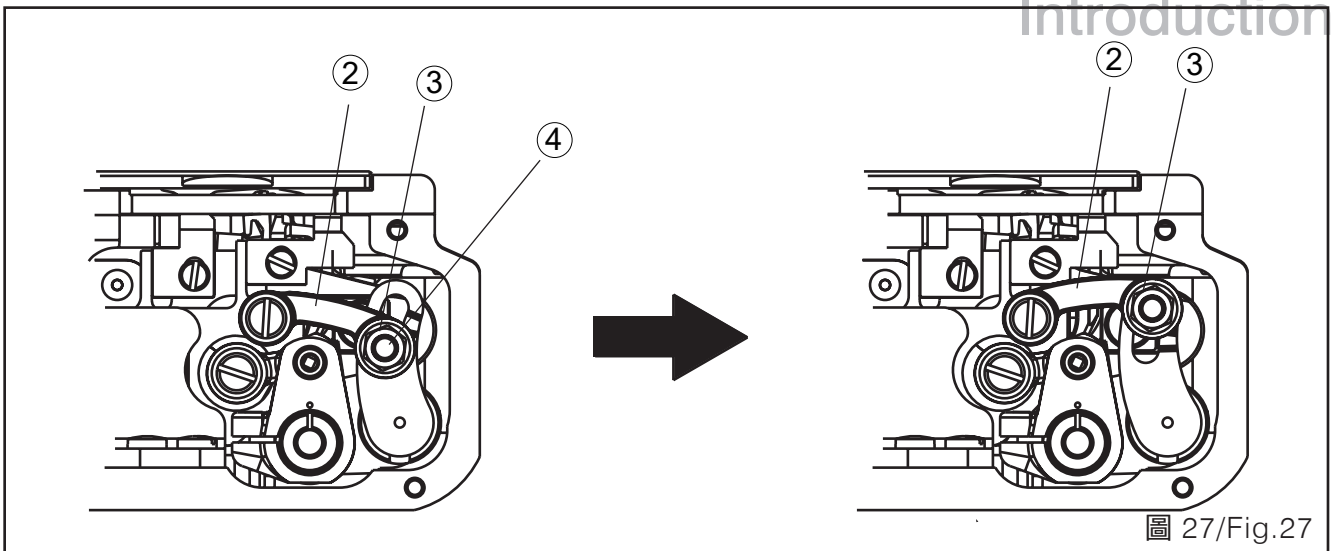
The differential ratio has been set from 1:0.7 to 1:1.4 at shipment.

將差動調節桿①對準差動送布刻度盤上的刻度線②時，差動送布牙與主送布牙的動作會一致（差動比 1:1），讓縫製動作同步。（圖 28）

When aligned the differential feed lever (right) ① with the line ② of the differential feed graduations, the movement of the differential feed dog is the same as that of the main feed dog (differential ratio 1:1), resulting in uniform sewing. (Fig. 28)

- (1) 鬆開固定螺帽③。
- (2) 旋轉調整螺絲④來調整差動送布牙的動作。  
縮短時請順時針旋轉。  
伸長時請逆時針旋轉。
- (3) 穩固地鎖緊固定螺帽③。

- (1) Loosen the lock nut ③.
- (2) Turn the adjusting screw ④ to adjust the movement of the differential feed dog.  
To increase the movement for gathering, turn it clockwise.  
To decrease the movement for stretching, turn it counterclockwise.
- (3) Tighten the lock nut ③ securely.



圖 28/Fig.28

## 縫目長度的調節

## ADJUSTING STITCH LENGTH

縫目長度的可調節範圍為 1.4 到 3.6mm。表四有分別顯示每一英寸 (25.4mm) 與每 30mm 時可包含的針數。

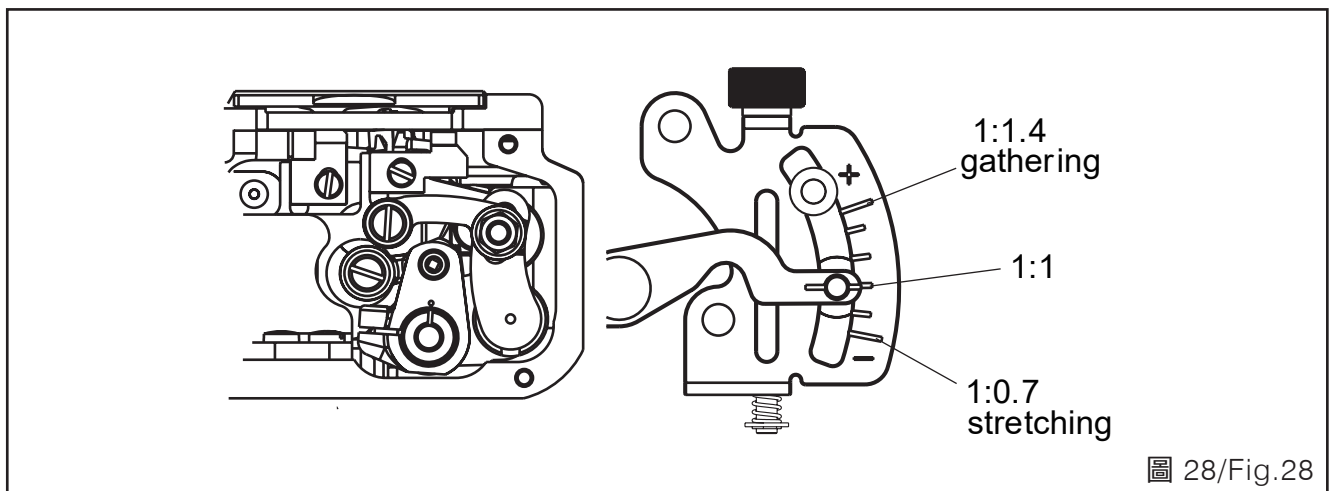
Stitch length is adjustable from 1.4 to 3.6 mm. Table 4 shows the number of the stitches per inch (25.4 mm) and 30 mm converted to the stitch length.

主送布桿擋片⑤在產品出廠時已被螺絲⑥固定，最大只能調節到 3.6mm。(圖 30)

The main feed lever stopper⑤ has been adjusted so as to stop at maximum 3.6 mm with the screw⑥ at shipment.(Fig.30)

調節步驟:(圖 29)

Adjusting procedure:(Fig.29)

1. 鬆開固定螺帽①。
2. 將主送布桿④對齊主送布刻度盤③上需求的位置。轉動調節螺絲②進行調節。

- 1.Loosen the lock nut①.
- 2.Align the end of the main feed lever④ with the required position on the main feed graduations③. Turn the main feed bar adjusting screw② to adjust it.

(1) 讓縫目長度變小請順時針旋轉。

(1)To make the stitch length smaller, turn it clockwise.

(2) 讓縫目長度變大請逆時針旋轉。

(2)To make the stitch length larger, turn it counterclockwise.

stitch length (mm)	number of stitch (per 1 inch)	number of stitch (per 30 mm)
1.4	18	21
2.0	13	15
3.0	8.5	10
3.6	7	8

表 4/Table 4

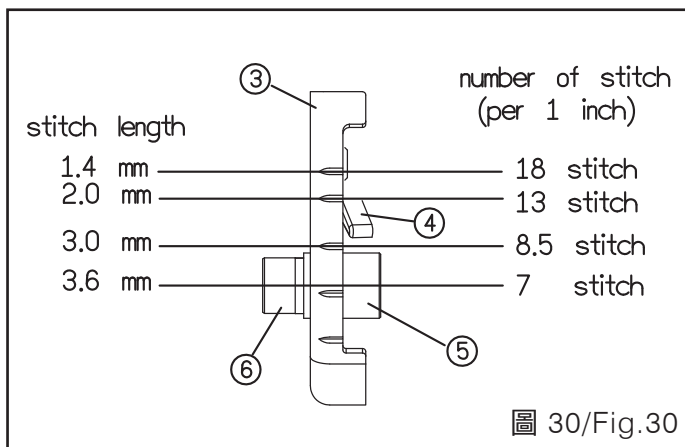
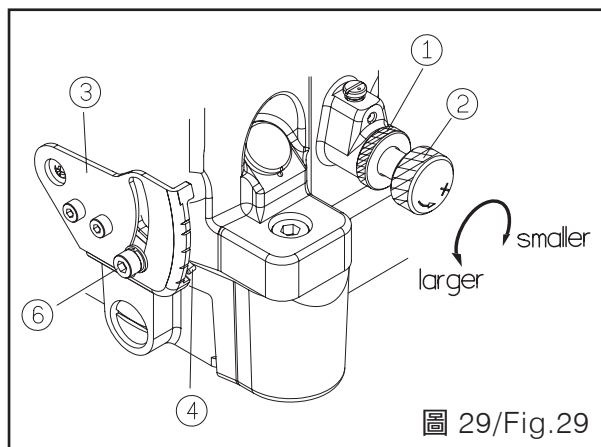

壓具壓力強度之調整

ADJUSTING PRESSURE OF THE PRESSER FOOT

在布料推送順暢且縫合完美之情況下，壓具壓力盡量輕些。（圖 31）

Pressure of the presser foot should be as light as possible, so that cloth can be feed and sewed smoothly. (Fig.31)



圖 31/Fig.31

操作環境照明

LIGHTENING OF THE OPERATION ENVIRONMENT

工業用縫紉品或是縫紉系統必須在該縫紉區域未啓動照明裝置前，禁止插電或通電；照明裝置的最大輸入功率應該能夠輕易辨識，當照明裝置設置或移動的時候，警示標誌也應該設置在照明裝置插座上或是附近。警示標示型式如圖 32 所示。

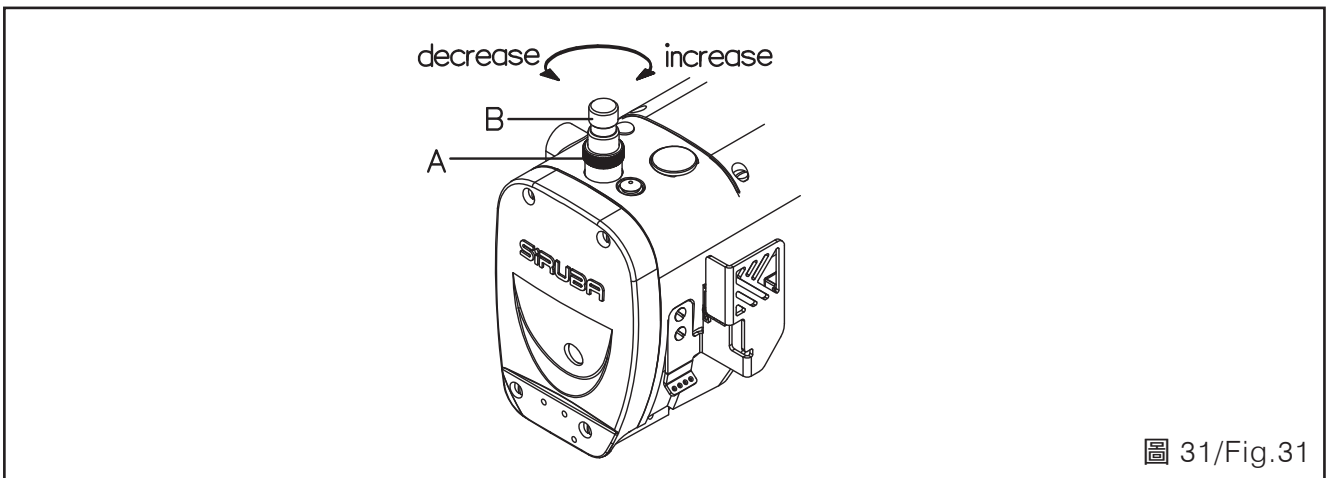
An industrial sewing unit or sewing system must always be unplugged from the local lighting of the sewing area before relamping, the marking of maximum rated input of a lamp shall be easily discernible while the lamp is being installed on or near the lamp socket as shown on Fig.32



圖 32/Fig.32

## 保養

## MAINTENANCE

### 《清潔送料具保養方式》

1. 抬起押具
2. 將兩個螺絲①拆下，然後拆下針板②。

### 《Maintain the feed dog》

1. Raise the presser foot.
2. Remove two screws①, and then remove the needle plate②.



圖 33/ Fig.33

3. 以軟毛刷清除送布牙③上的布屑。  
(圖 33)

3. Use a soft brush to clean dust and lints on the feed dog teeth③. (Fig.33)

4. 清潔後將針板②裝上。

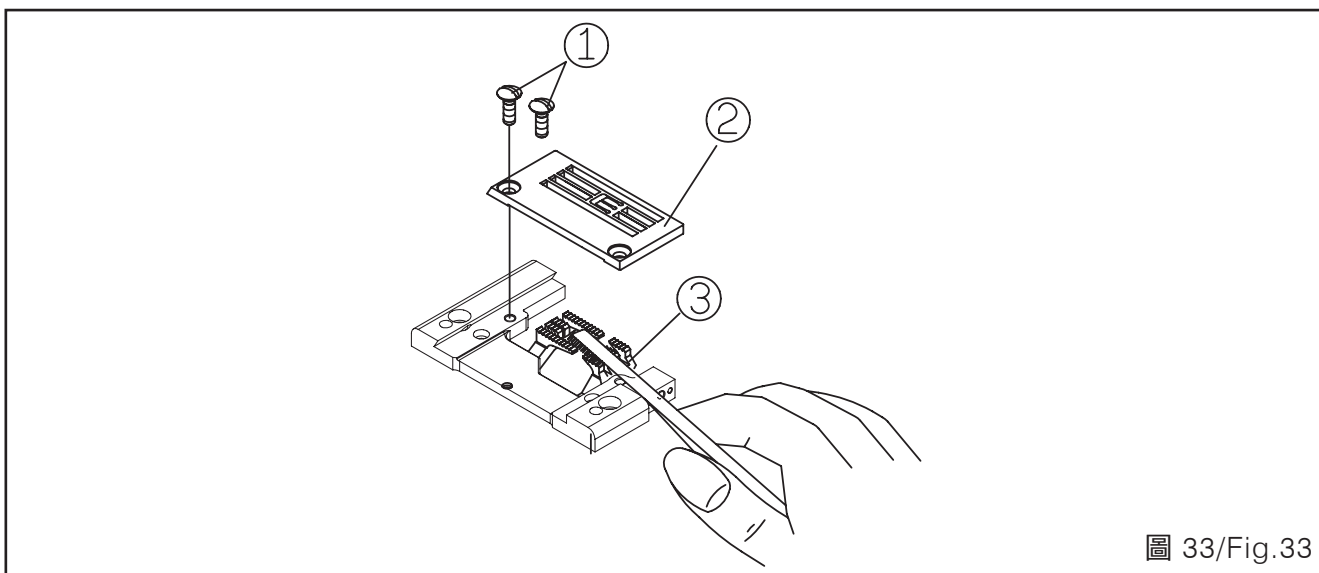
4. Install the needle plate② after doing the above cleaning.

### 《加油孔潤滑的保養》例：CRL

1. 將布屑和灰塵清掃乾淨；
2. 每週定期在加油孔的位置加注潤滑油，需加注潤滑油的位置如下圖：

### 《Maintenance of lubrication in the fueling holes》

1. Cleanse the fiber and dirt.
2. Weekly add the lubrication in the fueling holes.

The positions needed to be added lubrication as below :

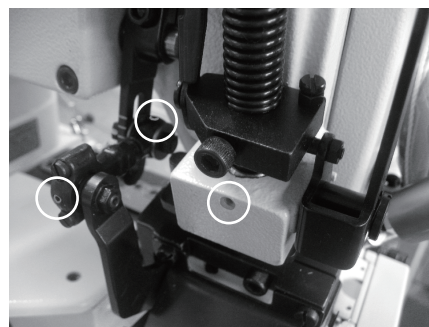
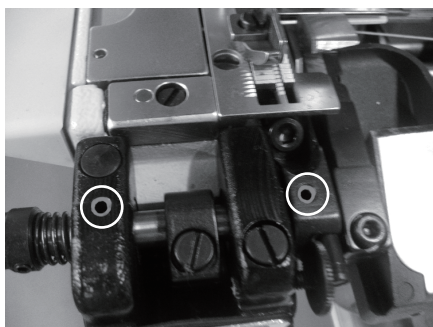
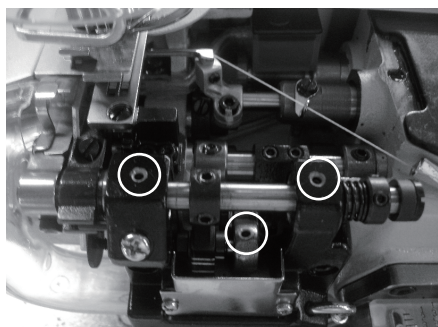

保養循環 Maintenance Cycle	保養項目 Maintenance Items
每天 Daily	1. 清潔送料具上之棉絮。 1. Clean the lint on the feed dog.
	2. 檢查油盤是否有足夠之液態油。(油量在油鏡之上、下兩紅漆記號間) 2. Check if there has enough liquid oil inside the oil pan. (The amount should be between the red up and down paint mark of the oil level gauge.)
	3. 保持機器及操作台清潔。 3. Keep the machine and the operation table clean.
每週 Weekly	1. 保持電源外觀乾淨。 1. Keep the power cords looking clean and neat.
	2. 保持操作面板乾淨。 2. Keep the operational panel clean.
	3. 檢查電源零件是否鬆脫或在正確位置。 3. Check if the power parts is loosening or still at the right position.
每三個月 Quarterly	1. 更換油盤內之液態油。 1. Replace the liquid oil inside the oil pan.
每年 Annually	1. 檢查傳動皮帶是否疲乏或毀損。 1. Check the transmission belt to see if it is weariful or damaged.

表 5/Table 5

## 潤滑

## LUBRICATION

1. 請選用 MOBIL#10 或 ESSO#32 或同級之潤滑油。
2. 由於新機器在裝運前已將油倒盡，因此新機器在使用前必須注入新油，轉開螺絲 A 將油注入機器中，待油量滿至油標指示上下線之間即可。(圖 34、35)

1. Please use Mobil# 10 or ESSO# 32 or its Equivalent oil.
2. The lubricating oil has been drained from the machine before delivery. Therefore, before using the new machine, remove screw (A), and fill the oil until the oil level is between the high/low indicate lines of oil level gauge. (Fig.34.35)



圖 34/Fig.34

3. 每天必須檢視，如果油已低於游標指示窗之下限，必須加注新油，當機器開始運轉，操作前，檢示必須整個潤滑系統使否順暢。

\* 開箱之新機器或許久未使用而重新要使用時，請在針棒上下部份加油潤滑。

3. Be sure to check every day and refill the oil, if oil level is lower than line L of oil level gauge.

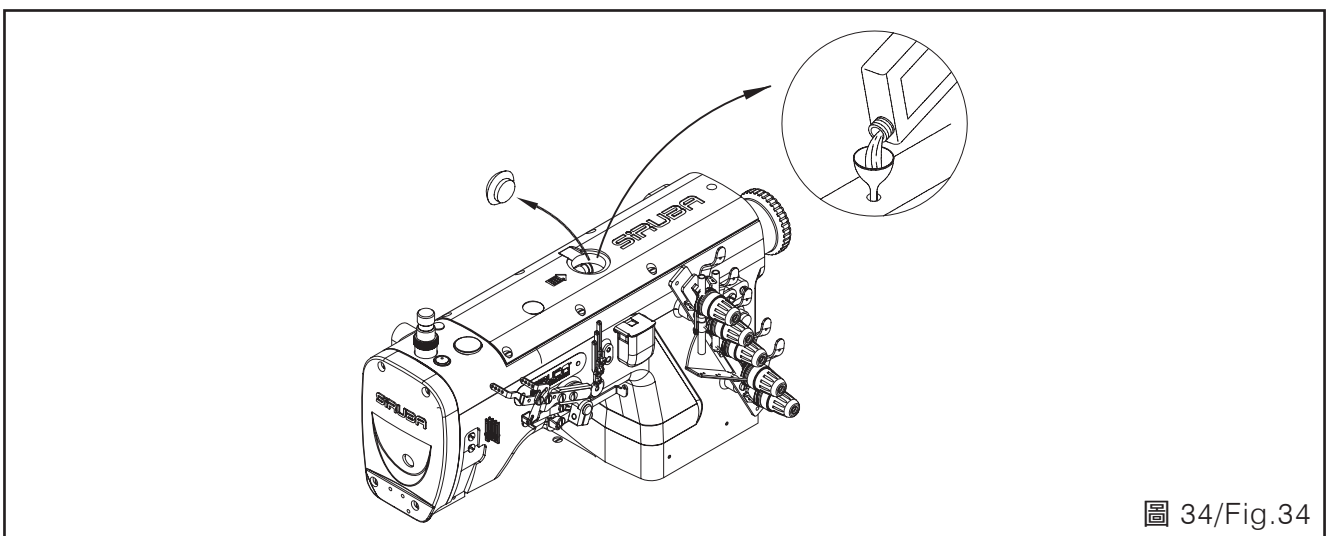
\* Before starting a brand new machine or a machine which has not been used for more than a couple of week, oiling the needle bar.



圖 35/Fig.35

## 針與線之冷卻與潤滑

## LUBRICATE AND THE COOLING OF NEEDLE AND THREAD

將矽油注入①及②油槽以防止斷線。(圖 36)

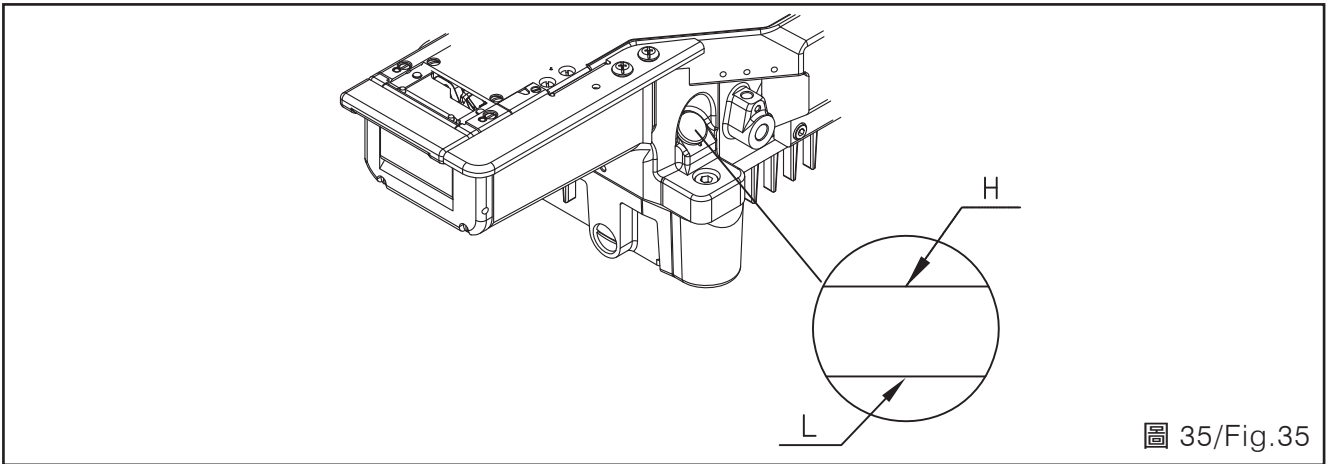
Fill reservoir ① and ② with silicon oil to prevent the thread from breaking. (Fig.36)



圖 36/Fig.36

## 潤滑油之更換

## CHANGE THE LUBRICATION OIL

1. 將螺絲 D 鬆開，使油槽之油完全排出後再鎖緊。(圖 37)

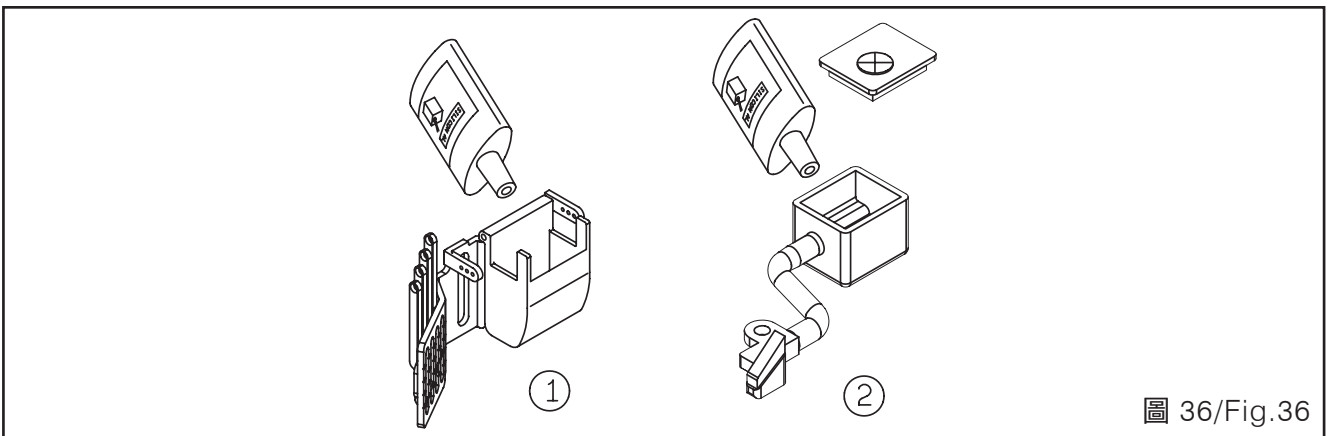
2. 為延長本機器壽命，請於開始使用一個月後更換新油，爾後約每四個月更換一次。

1. Loosen screw D and fasten it after drain all the oil from the tank. (Fig.37)

2. For extending the life of the machine, change oil after the first month operation. After that, change oil every four months.



圖 37/Fig.37

### 濾油器之更換

### CHANGE THE OIL FILTER

本機器特別裝有濾油器，約每使用一個月後應卸下清洗，必要時得換新品。（圖 38）

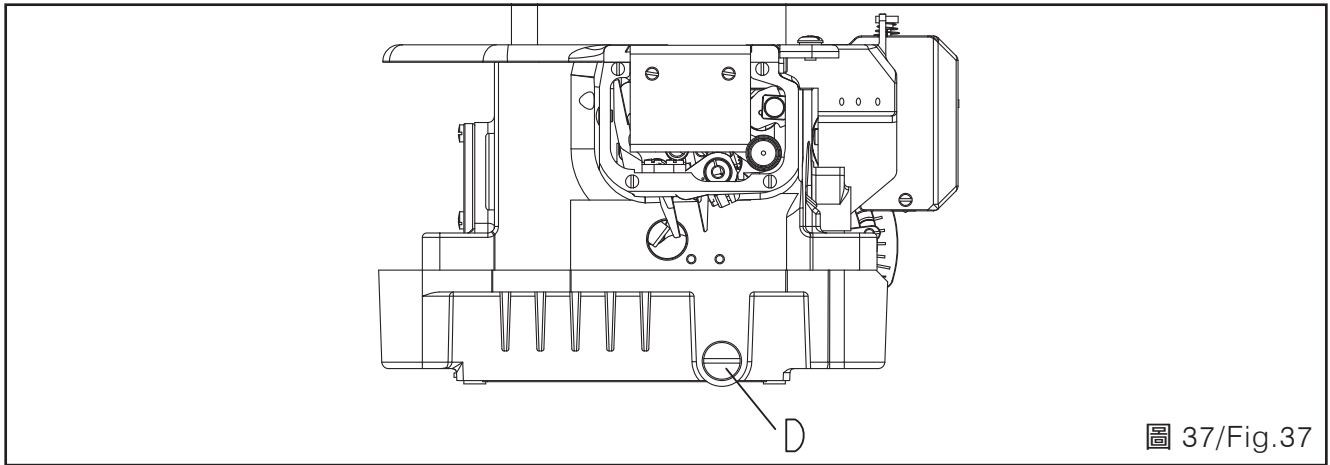
This machine is equipped with an oil filter, and the filter must be cleaned every month. Replace the filter if necessary. (Fig.38)



圖 38/Fig.38

### 針之更換

### REPLACE THE NEEDLE

1. 選用針之規格與尺寸請參照（表 6）
2. 旋開螺絲①並取下針，將新針插至針座最底端，並使針之長溝面向自己。（圖 39）
3. 重新鎖緊螺絲①。

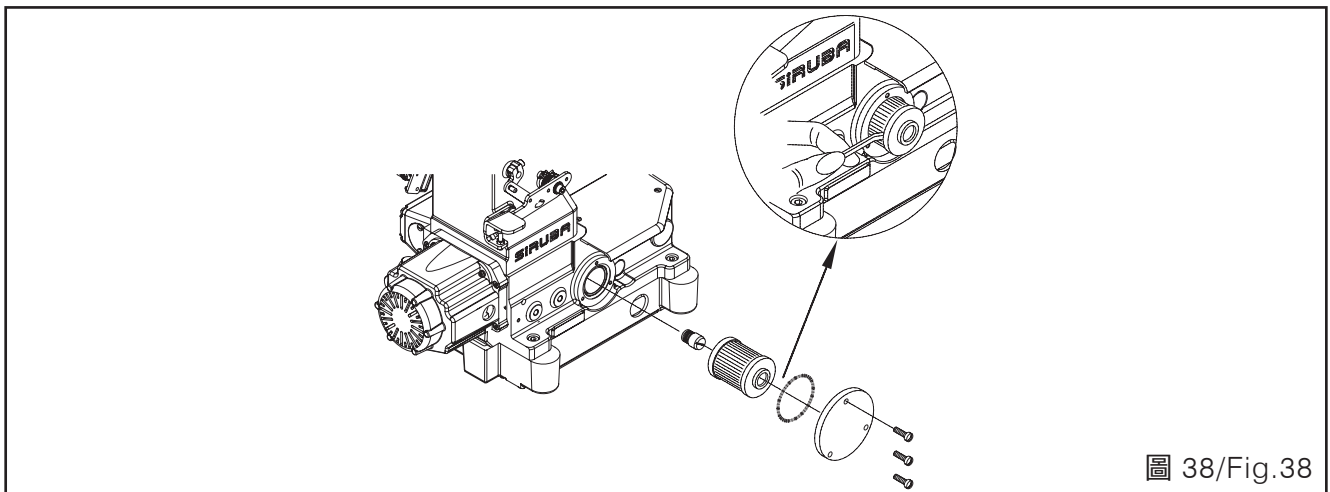
\*特殊機種針之代號請參考規格件表。

1. See Table 6 for the sizes and the specifications of the needles.
2. Loosen screw ①, then pull out the used needles. Insert the new needles into the holder holes as far as they can go, and let the long groove of the needle face you. (Fig.39)
3. Fasten screw ①.

\* Needle size of special model, please refer to conversion chart.



圖 39/ Fig.39

針代號 Needle System	針尺寸 Needle Size		
	2針 2 Needles	3針 3 Needles	4針 4 Needles
ORGAN UY128GAS	#10		
ORGAN SM1014B			#10

表 6 / Table 6

## 結束密縫調整

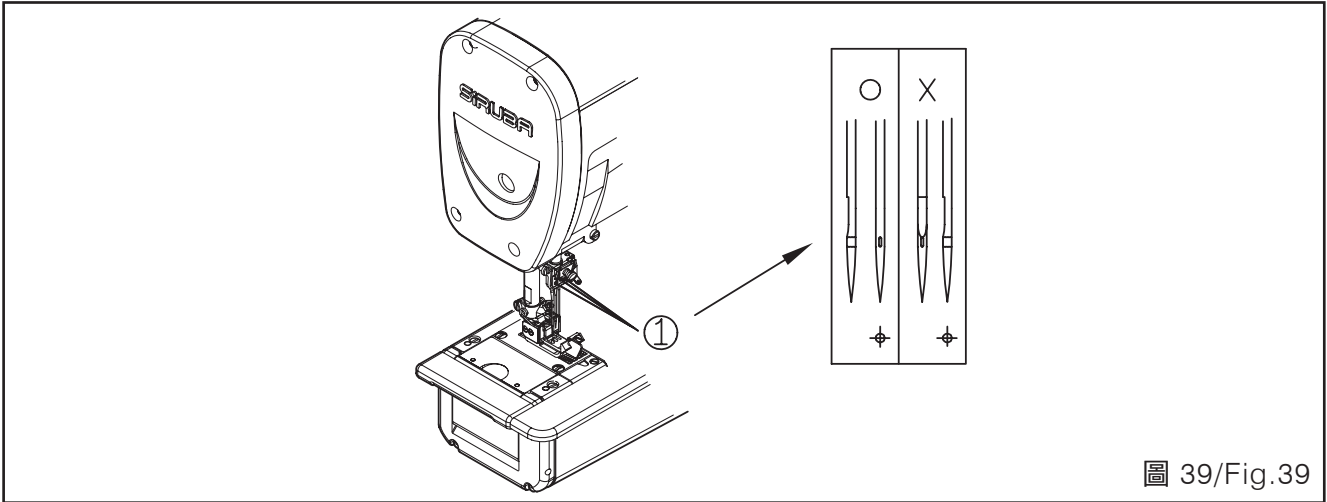
## ADJUSTING END INTENSIVE SEWING

氣動結束密縫說明：結束密縫功能設計，將結束密縫驅動桿①以鍊條②鉤住，以腳動方式將結束密縫驅動桿①往下拉伸，透過結束密縫功能，可使車縫末端線跡更密集，使縫線線跡不易脫落，其標準配備為腳動，亦可選配由電子馬達控制箱動作，進行車縫末端結束密縫。（圖 40）

The instruction of pneumatic end intensive: End intensive sewing function- hook the end intensive sewing driving lever ① by the chain ② and stretch down the end intensive sewing driving lever ① by foot-action, which enable the end stitch more intensive and strong. The standard equipment of end intensive sewing is foot-action, but the electronic motor control box can be option too. (Fig.40)



圖 40/ Fig.40

## 故障檢修

## TROUBLESHOOTING

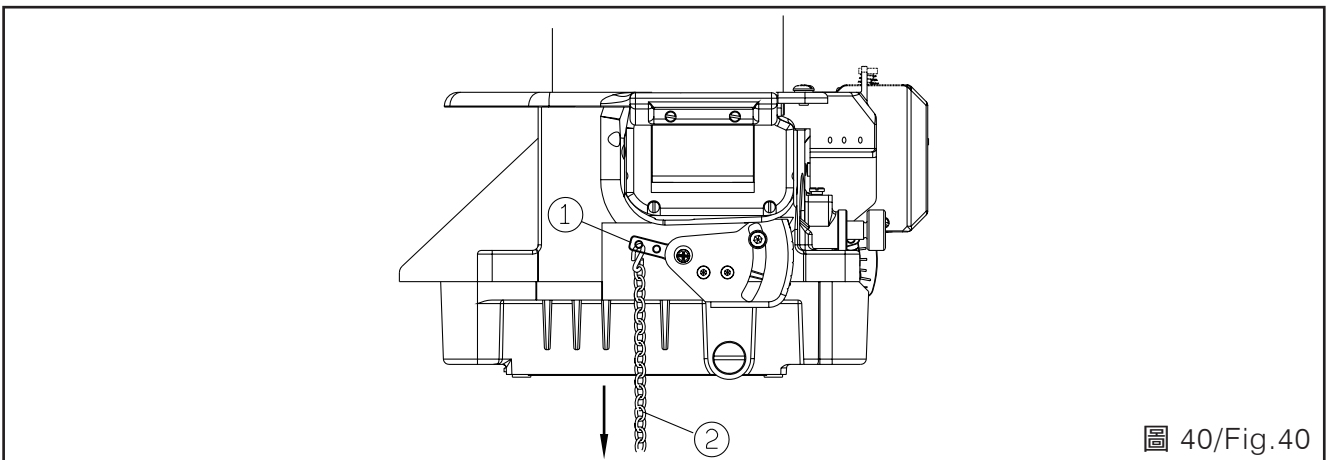

## 注意CAUTION



在進行故障檢修查詢之前，請先關閉電源並拔出電源，否則如果誤觸啓動開關，縫紉機會動作，易導致人身受傷。

Before processing the troubleshooting, please turn off the power switch and unplug the electronic cord. Otherwise, if touching the start switch incautiously, the sewing machine will function and will probably cause injuries happened on operators.

No.	現象 Problem	檢查及調整 Exam and Adjustment
1.	針線太過緊密/疏鬆 Needle thread too tight/ loose	<ul style="list-style-type: none"> <li>●針線張力是否過大或過小？ The tension of the needle thread is too loose or too tight?</li> <li>●調整針線張力。 Adjust the needle thread tension.</li> </ul>
2.	針線的跳線現象 The skipping stitch of needle thread	<ol style="list-style-type: none"> <li>1.車針的選擇不對？ Choose the wrong needle?</li> <li>●選擇配合布料的車針與縫線號碼。 Select the needle and thread number match the fabrics.</li> <li>2.車針不良？ Bad needle?</li> <li>●換新車針。 Change a new needle.</li> <li>3.穿線方式不正確。 Incorrect threading.</li> <li>●按照穿線圖。 Follow the threading diagram.</li> <li>4.車針安裝不正確。 Incorrect needle installation.</li> <li>●重新安裝車針，使車針長槽朝向操作者。 Reinstall the needle to make the long slot of needle face the operator.</li> <li>5.車針針尖斷或彎曲。 The needle tip is broken or bent.</li> <li>●換新車針。 Change a new needle.</li> <li>6.勾針針尖變鈍。 The looper tip is blunt.</li> <li>●使用油石或細砂紙修磨，或換新勾針。 Polish by the oilstone or fine emerypaper. Or replace with new looper.</li> <li>7.勾針線張力太大或太小。 The looper tension is too loose or too tight.</li> <li>●適當調整縫線張力。 Adjust the thread tension properly.</li> </ol>

No.	現象 Problem	檢查及調整 Exam and Adjustment
2.	<p>針線的跳線現象。 The skipping stitch of needle thread</p>	<p>8. 勾針不能套住右邊車針的線環，造成勾針線的右邊線跡跳針。 The looper can't hook the right needle thread loop and cause the right stitch of looper thread skipped. ●主因為車針線環太小，增加挑線量。 Because the needle thread loop is too small which increase the thread take-up amount.</p> <p>9. 勾針不能套住左邊車針的線環，造成勾針線的左邊線跡跳針。 The looper can't hook the left needle thread loop and cause the left stitch of looper thread skipped. ●主因為車針線環太大，減少挑線量。 Because the needle thread loop is too big which decrease the thread take-up amount.</p> <p>10. 勾針無法勾住中間與左邊直針線環，勾針線的中針線與左針線跳針。 The looper can't hook the middle and left straight needle thread loop which cause the middle and left stitch of looper thread skipped. ●依標準調整車針與勾針的勾線關係，使車針線環大小適當。 According to the standard to adjust the looper thread connection between needle and looper and make proper needle thread loop size.</p> <p>11. 勾針無法勾住中間與右邊直針線環，勾針線的中針線與右針線跳針。 The looper can't hook the middle and right straight needle thread loop and cause the middle and right stitch skipped. ●檢查縫線是否有穿過夾線器，控線凸輪的同步關係，有問題依標準進行調整。 Check if the thread pass through the thread gripper and the synchronization relationship of thread controlling cam. If there is any problem, adjust it according to the standard.</p> <p>12. 勾針與車針配合不當。 The looper and needle didn't cooperate well. ●檢查針桿高度，車針與勾針之間的同步。 Check the needle lever height and the synchronization between needle and looper.</p> <p>13. 車針與護針片配合不當。 The needle and the needle guard plate didn't cooperate well.</p>

No.	現象 Problem	檢查及調整 Exam and Adjustment
2.	針線的跳線現象。 The skipping stitch of needle thread	<ul style="list-style-type: none"> <li>●檢查車針與護針片位置，如有問題，按標準進行調整。 Check the position of needle and needle guard plate. If there is any problem, adjust it according to the standard.</li> <li>14.車針與上勾針配合不當，或上勾針位置不對，造成上勾針跳針。 The needle and up looper didn't cooperate well or the incorrect up looper position cause the up looper skipped.</li> <li>●檢查車針與上勾針的配合尺寸及上勾針出線量，如有問題，按標準進行調整。 Check the size of needle and up looper and the thread output amount of up looper. If there is any problem, adjust it according to the standard.</li> </ul>
3.	縫紉開始時出現跳針或脫線 Skipped stitches or unraveled thread at sewing start	<ul style="list-style-type: none"> <li>1.機針過粗。 The needle is too thick.</li> <li>●使用比現有機針小一號的機針。 Try using a needle with a count that is one lower than the current needle.</li> <li>2.縫紉開始時，縫紉速度過快。 The sewing speed is too fast at the sewing start.</li> <li>●使用慢速起縫。 Use the slow start feature.</li> </ul>
4.	斷線 Thread broken	<ul style="list-style-type: none"> <li>1.穿線方法不正確。 Incorrect threading.</li> <li>●按穿線圖重新穿線。 According to the threading diagram to re-threading.</li> <li>2.車針安裝不正確。 Incorrect needle installation.</li> <li>●重新安裝車針，使車針溝朝向操作者。 Reinstall the needle to make the needle slot face the operator.</li> <li>3.縫線張力過大。 The thread tension is too strong.</li> <li>●適當調整縫線張力。 Adjust the thread tension properly.</li> <li>4.縫線質量太差。 Bad thread quality.</li> <li>●改用適當縫線。 Change to use the proper thread.</li> <li>5.縫線比針孔粗。 The thread is wider than the needle hole.</li> <li>●改換適中的縫線或針。 Change to use the proper thread or needle.</li> </ul>

No.	現象 Problem	檢查及調整 Exam and Adjustment
4.	斷線 Thread broken	<p>6.車針、勾針、針板、壓具舌、過線孔等過線處有毛次或有刮傷現象。 The needle, looper, needle plate, presser foot tongue and thread crossing hole is blunt or scratching.</p> <ul style="list-style-type: none"> <li>●用油石或細砂紙重新修磨，或更換新零件。 Use oilstone or fine emerypaper to polish or replace the parts.</li> </ul> <p>7.縫線車縫厚布料產生繞線現象。 Sewing the heavy material cause the thread winding.</p> <ul style="list-style-type: none"> <li>●降低車縫轉度，添加矽油降低針及線摩擦溫度。 Decelerate the sewing rotational speed and applying silicon oil to lower the friction temperature between needle and thread.</li> </ul>
5.	斷針 Needle broken	<p>1.車針的選擇不對。 Choose the wrong needle.</p> <ul style="list-style-type: none"> <li>●在布料不發生針孔的範圍內，使用粗一點的車針。 Use thick needle within the range that there will be no pinhole occurred on the fabric.</li> </ul> <p>2.壓具安裝不良。 Improper assembling of the presser foot.</p> <ul style="list-style-type: none"> <li>●安裝時必須使用車針會插進壓具落針處中央。 During assembly, make sure the needle can insert to the central point of the presser foot.</li> </ul> <p>3.送具安裝高低位置不對。 The assembling height of feed dog is wrong.</p> <ul style="list-style-type: none"> <li>●調整送具的高度，送齒高於針板0.8~1 mm，同時保持適當壓具壓力。 Adjust the feed dog height to make the feed teeth in 0.8~1 mm higher that the needle plate and keep the appropriate presser foot pressure.</li> </ul> <p>4.縫線不良。 Bad threading.</p> <ul style="list-style-type: none"> <li>●縫線有結頭要事先加以處理後，重新穿線。 If there is any connecting part of the thread, it needs to be dealt first. Then, threading.</li> </ul> <p>5.車針安裝不正確。 Improper needle installing.</p> <ul style="list-style-type: none"> <li>●依說明書正確安裝方式，進行安裝。 Install the needle correctly by following the instruction book.</li> </ul> <p>6.車針彎曲或針尖斷裂起毛或針孔被堵住。 The needle is bent, the needle tip broken, or the needle hole is blocked.</p> <ul style="list-style-type: none"> <li>●更換機針。 Replace the needle.</li> </ul>

No.	現象 Problem	檢查及調整 Exam and Adjustment
5.	斷針 Needle broken	<p>7. 壓具壓力過小、送布不良。 The presser foot pressure is small or the fabric feeding is improper.</p> <p>●增加壓腳壓力，使送布正常。 Increase the presser foot pressure to adjust the fabric feeding properly.</p> <p>8. 勾針與車針相碰。 The looper contact the needle.</p> <p>●按標準調整勾針與車針位置。 Adjust the position of needle and looper according to the standard.</p> <p>9. 上勾針與車針相碰。 The up looper contact the needle.</p> <p>●按標準調整上勾針與車針位置。 Adjust the position of the upper looper and needle according to the standard.</p> <p>10. 車針與護針片配合不當。 The needle and needle guard plate didn't cooperate well.</p> <p>●按標準調整車針與護針片位置。 Adjust the position of the needle and needle guard plate according to the standard.</p> <p>11. 勾針尖鈍。 The looper tip is blunt.</p> <p>●更換勾針。 Replace the looper.</p> <p>12. 針桿與針桿套筒磨損過大，使車針與針桿套配合鬆動。 The needle lever and needle lever sleeve is worn out so the needle and needle sleeve become loose.</p> <p>●更換針桿或針桿套筒。 Replace the needle rod or needle rod sleeve.</p> <p>13. 針板上容針孔太小。 The needle hole on the needle plate is too small.</p> <p>●更換小號車針或更換容針孔較大針板。 Replace the smaller needle or the needle plate with bigger needle hole.</p> <p>14. 零件鬆動過大。 The parts is over-loosing.</p> <p>●檢查各機構之間配合與磨損狀況，按標準調整配合尺寸，對於磨損嚴重機件進行更換。 Check cooperation and wear condition among the mechanism and adjust the size according to the standard. Replace the part which is worn out seriously.</p>

No.	現象 Problem	檢查及調整 Exam and Adjustment
5.	斷針 Needle broken	<p style="text-align: center;"> <b>注意CAUTION</b></p> <p>請儘可能找出斷掉的機針，避免斷針掉入縫製物造成刺傷人的危險。 In order to prevent the broken needle sticking in the material and stab people so please search for broken needle until the whole of the needle is found.</p>
6.	線跡不規則 Uneven stitch	<p>1.車針太低使車針線環形成太大，使線圈之間相互交織在一起。 The lower needle cause the big thread loop and make the thread loop intertwist together. ●按標準重新定位車針高度。 Reset the needle height by following the standard.</p> <p>2.針板舌頭部太窄，使車針圈容易產生併攏而線跡產生不規則。 The needle plate tongue is too narrow which make the needle come close easily and have uneven stitch. ●更換新針板。 Replace with the new needle plate.</p> <p>3.車針與勾針配合不良。 The needle and looper didn't cooperate well. ●按標準調整車針與勾針配合位置。 Adjust the needle and looper position by following the standard.</p>
7.	縫線不平整 Uneven Seam	<p>1.壓具壓力過小？ The presser foot pressure is too weak? ●調整壓具壓力。 Adjust the presser foot pressure.</p> <p>2.送具送齒過低。 The feed dog teeth is too low. ●調整送具送齒高度。 Adjust the feed dog teeth height.</p>
8.	縫布料皺起起 The fabric is puckering	<p>1.差動送布比率不當。 The improper differential fabric feeding ratio. ●適當調整差動送布比率。 Adjust the differential fabric feeding ratio properly.</p> <p>2.送具送齒高低前後位置不當。 The improper position of feed dog teeth. ●按標準調整送具送齒高低。 According to the standard to adjust the feed dog teeth height.</p> <p>3.縫線張力過大。 The stitch tension is too strong. ●適當調整縫線張力。 Adjust the stitch tension properly.</p>

No.	現象 Problem	檢查及調整 Exam and Adjustment
8.	縫布料皺起 The fabric is puckering	4. 壓具壓力太大或太小。 The presser foot pressure is too strong or too weak. ● 適當調整壓具壓力。 Adjust the presser foot pressure properly. 5. 縫紉速度過快。 The sewing speed is too fast. ● 降低車縫速度。 Decelerate the sewing speed.
9.	縫跡不良 Improper stitch	1. 線的粗細不一致。 The thread thickness is different. ● 改用較好的縫線。 Change to use the better thread. 2. 夾線器工作不正常。 The thread gripper is abnormal. ● 清除夾線器雜物，使過線平順。 Clean the thread waste on the thread gripper to make the thread crossing smoothly. 3. 過線器定位不正確。 The locating of thread crossing is incorrect. ● 調整針線、勾針線及上勾針線的張力。 Adjust the tension of needle thread, looper thread and up looper thread. 4. 過線孔不光滑。 The thread crossing hole is not smooth. ● 用砂紙或挫刀工具拋光過線孔。 Use emerypaper or file to polish the thread crossing hole.
10.	縫布料出現針孔 There is needle hole on the fabric	1. 車針針尖變鈍或起毛。 The needle tip is blunt. ● 更換車針。 Replace the needle. 2. 與縫布料比較，車針太粗。 The needle which compares with fabric is too thick. ● 換用較細車針。 Replace with the fine needle. 3. 針板上容針孔太小或磨損。 The needle hole on the needle plate is too small or worn out. ● 把針板孔修圓滑。 Rounding and smooth the needle plate hole.

No.	現象 Problem	檢查及調整 Exam and Adjustment
11.	不能噴油 The oil does not splash	1. 泵浦不出油。 The oil does not come out from the pump. ●更換泵浦不良零件 Change the improper parts of pump. 2. 上機構不噴油。 The Upper mechanism does not splash the oil. ●更換濾油器，用鐵絲疏通油路。 Change a new filter and use the iron wire to clean through the oil path.
12.	大聲、異聲 Loud noise, strange noise	1. 針棒鬆動。 The needle bar is loosening. ●更換新品或磨合其接觸面使之間隙變小。 Change a new one or to polish the contacting surface so that clearance is smaller. 2. 皮帶輸出聲。 The pulley has noise. ●按基準調整之。 Adjust it based on the standard.
13.	打開電源並踩下腳踏板時，縫紉機不動作。 Machine does not operate when power is turned on and treadle is pressed.	1. 電源插頭從控制箱上鬆開。 The power supply connector disconnected from the control box. ●將插頭插牢。 Insert the connector securely.
14.	縫紉機不能以高速運轉。 Machine does not operate at high speed.	1. 縫紉機速度設定過低。 The sewing speed is setting too slow. ●請重新設定縫紉機轉速。 Please reset the sewing rotational speed.
15.	加裝 CL 如遇抬壓腳力道不足時。 If the strength or the presser foot lifter is insufficient with being equipped with CL.	請依下列實施： A . 參數 64 項，出廠值：40 改為 100 B . 參數 65 項，出廠值：10 改為 28 Please implement the procedure as below: A .Parameter No.64,default: 40 change to 100. B .Parameter No.65,default: 10 change to 28.

**SIRUBA**

TABLE  
CUT - OUT

Series

C007L/C007LD

Item Code

C007L-T23

Subclass / Remark

Mounting

Semi-submerged

Date

2018/12/12

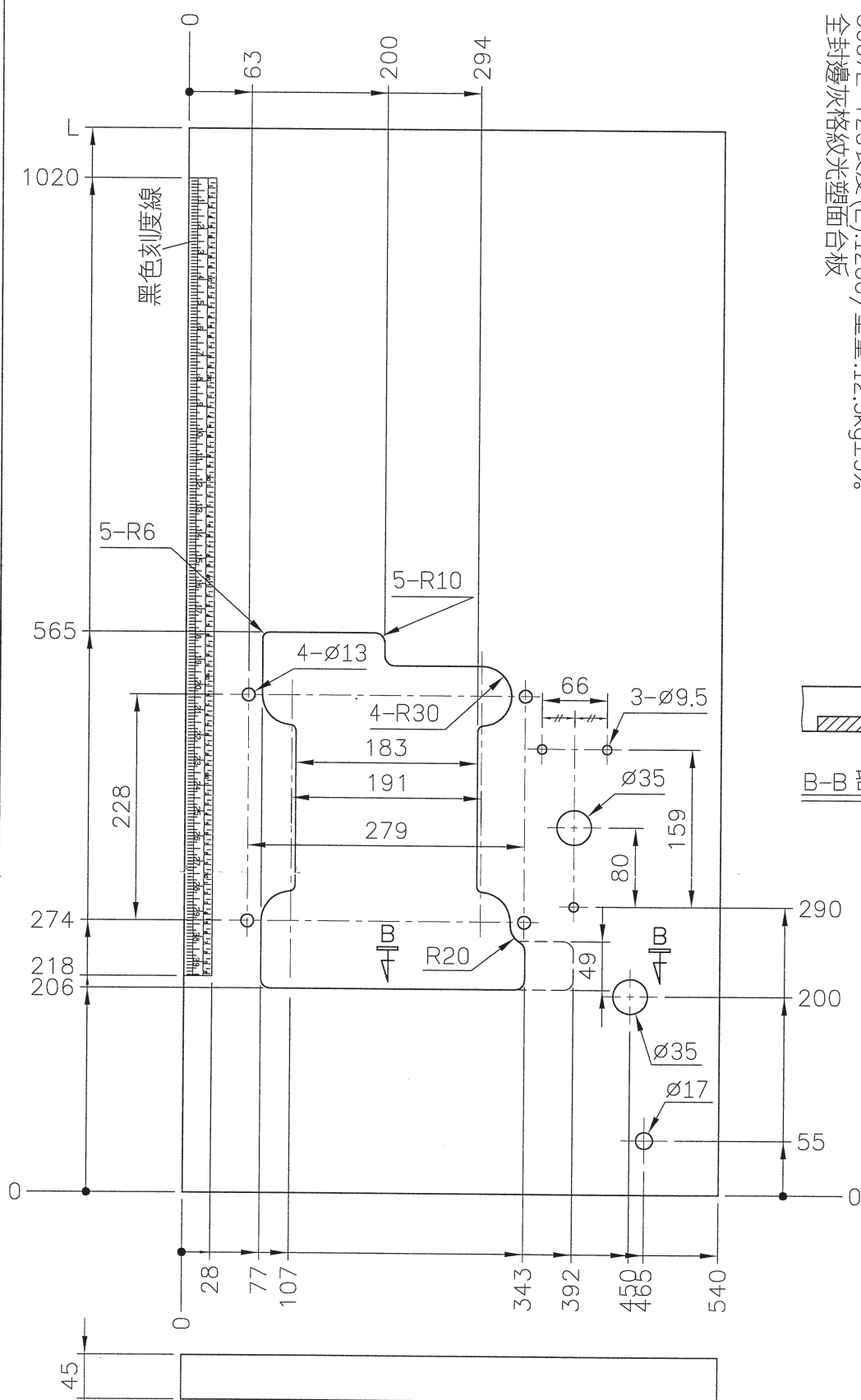

三針筒車下乘桌板圖  
C007L/C007LD SERIES TABLE CUT-OUT SEMI-SUBMERGED  
單位/UNIT:mm  
FOR一般車及自動切線  
所有尺寸公差/DIFFERENCE:±2  
C007L-T23 長度(L):1070/重量:11.5kg±5%  
C007L-T23 長度(L):1200/重量:12.5kg±5%  
全封邊加格紋光塑面台板

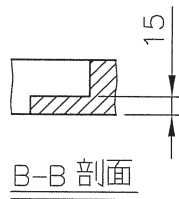



<b>SIRUBA</b> TABLE CUT - OUT	Series	Item Code	Subclass / Remark	Mounting
	C007LD	C007LD-T30		Non-submerged
				Date
				2019/11/25

三針筒車上乘式桌板  
 C007LD SERIES TABLE CUT-OUT Non-submerged  
 單位/UNIT:MM  
 FOR一般車及自動切線  
 所有尺寸公差/DIFFERENCE:±2  
 全封邊/灰格紋光塑面台板

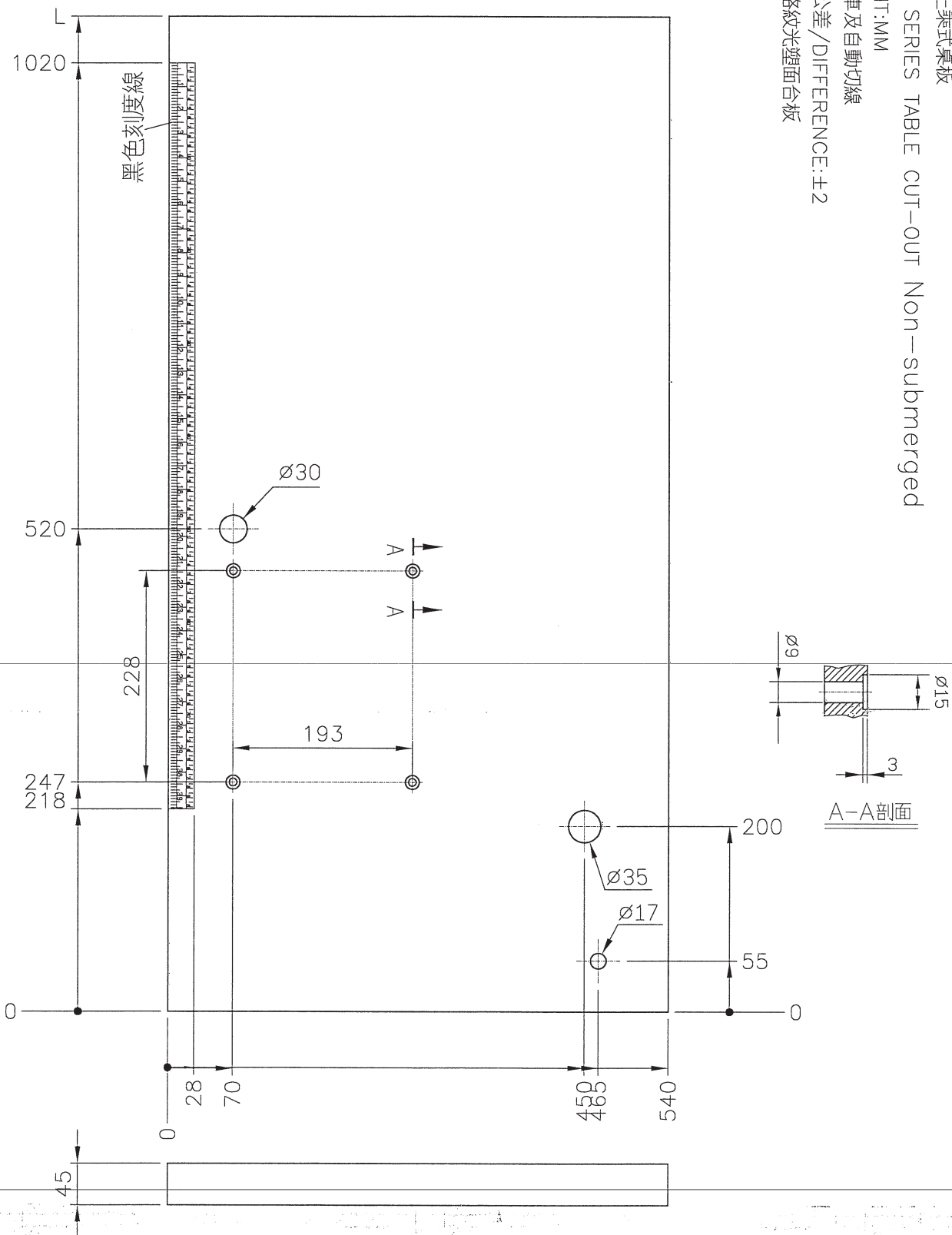

SIRUBA PARTS LIST	Series	Parts Group	Subclass / Remark	Page
	C007L	MF-L		1/1
				Date
				2019/09/23

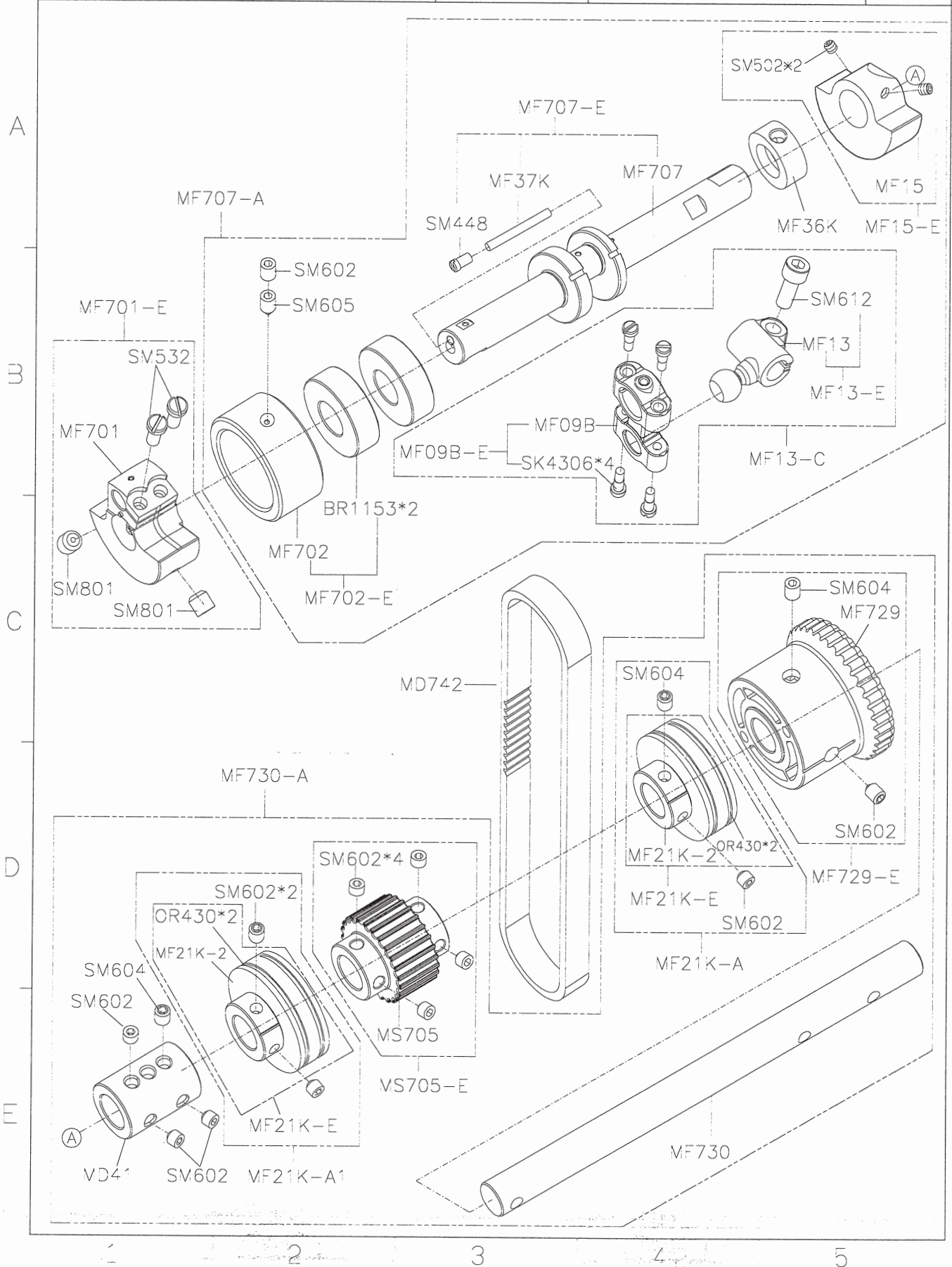

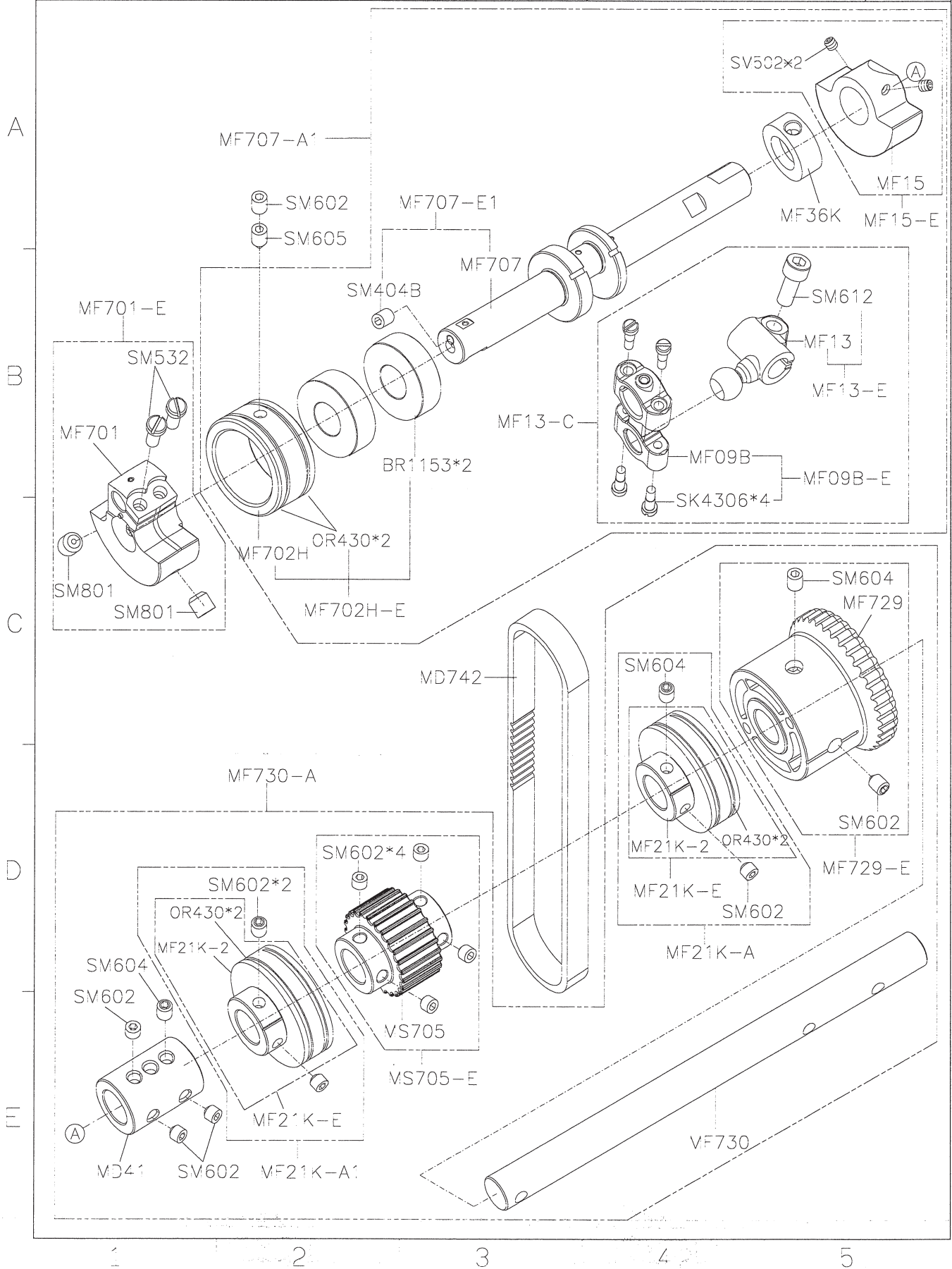

SIRUBA PARTS LIST	Series	Parts Group	Subclass / Remark	Page
	C007L/C007LD	MG-L		1/1
				Date
				2017/11/15

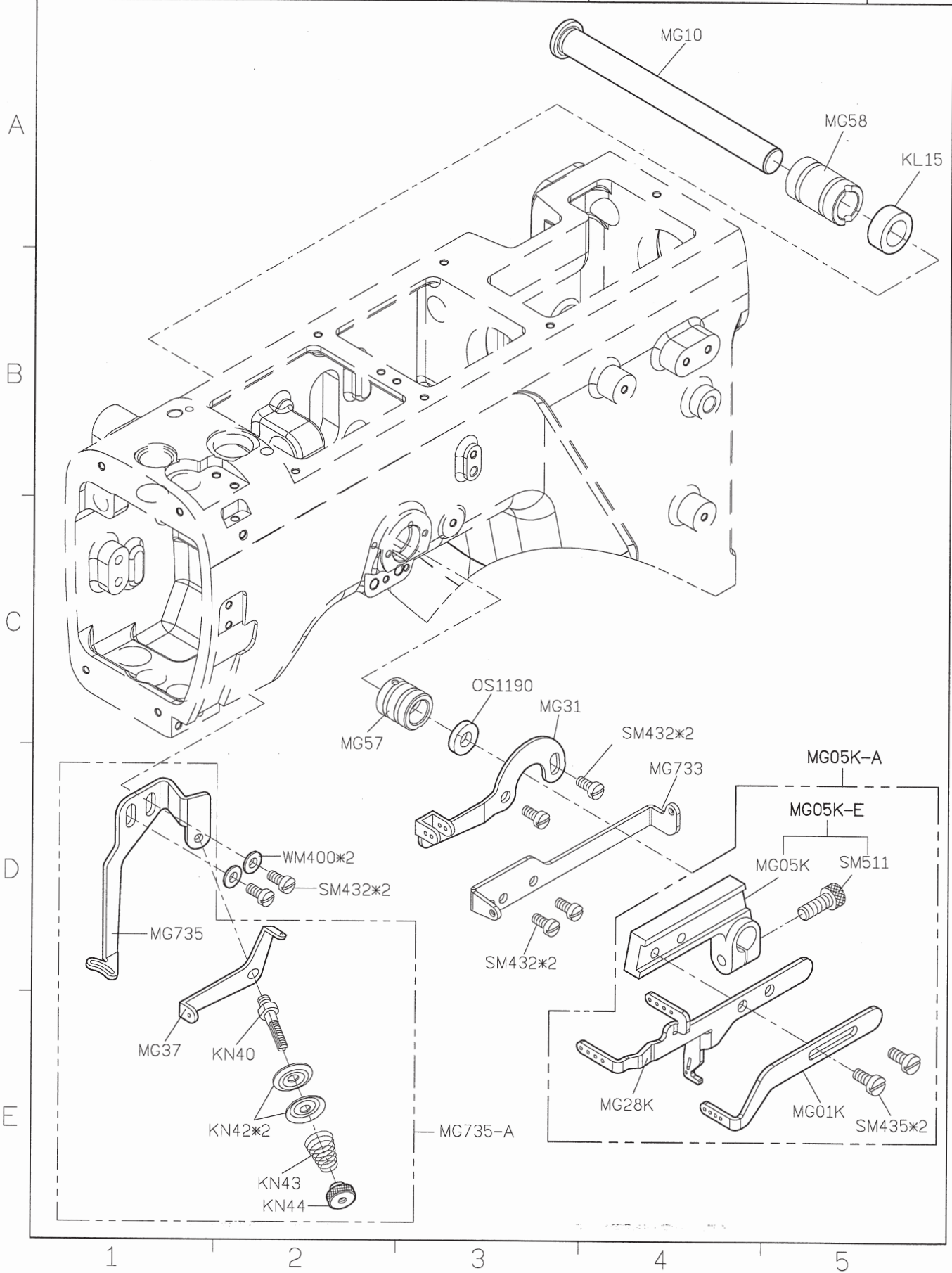

SIRUBA PARTS LIST	Series	Parts Group	Subclass / Remark	Page
	C007L	MH-L	*Use for allocation	1/1
				Date
				2021/11/12

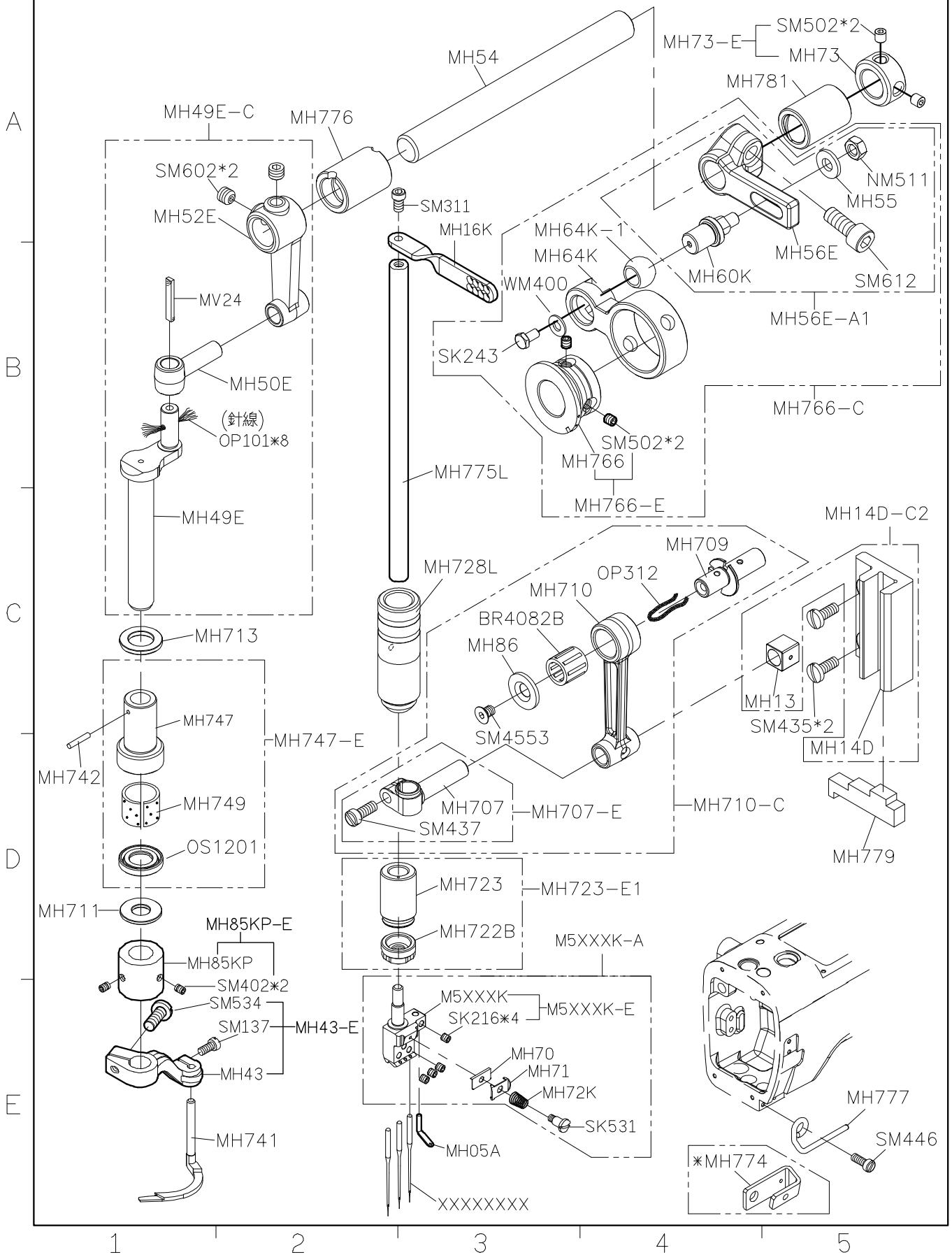

SIRUBA PARTS LIST	Series	Parts Group	Subclass / Remark	Page
	C007LX	MH-L	*Use for allocation	1/1
				Date 2022/3/28

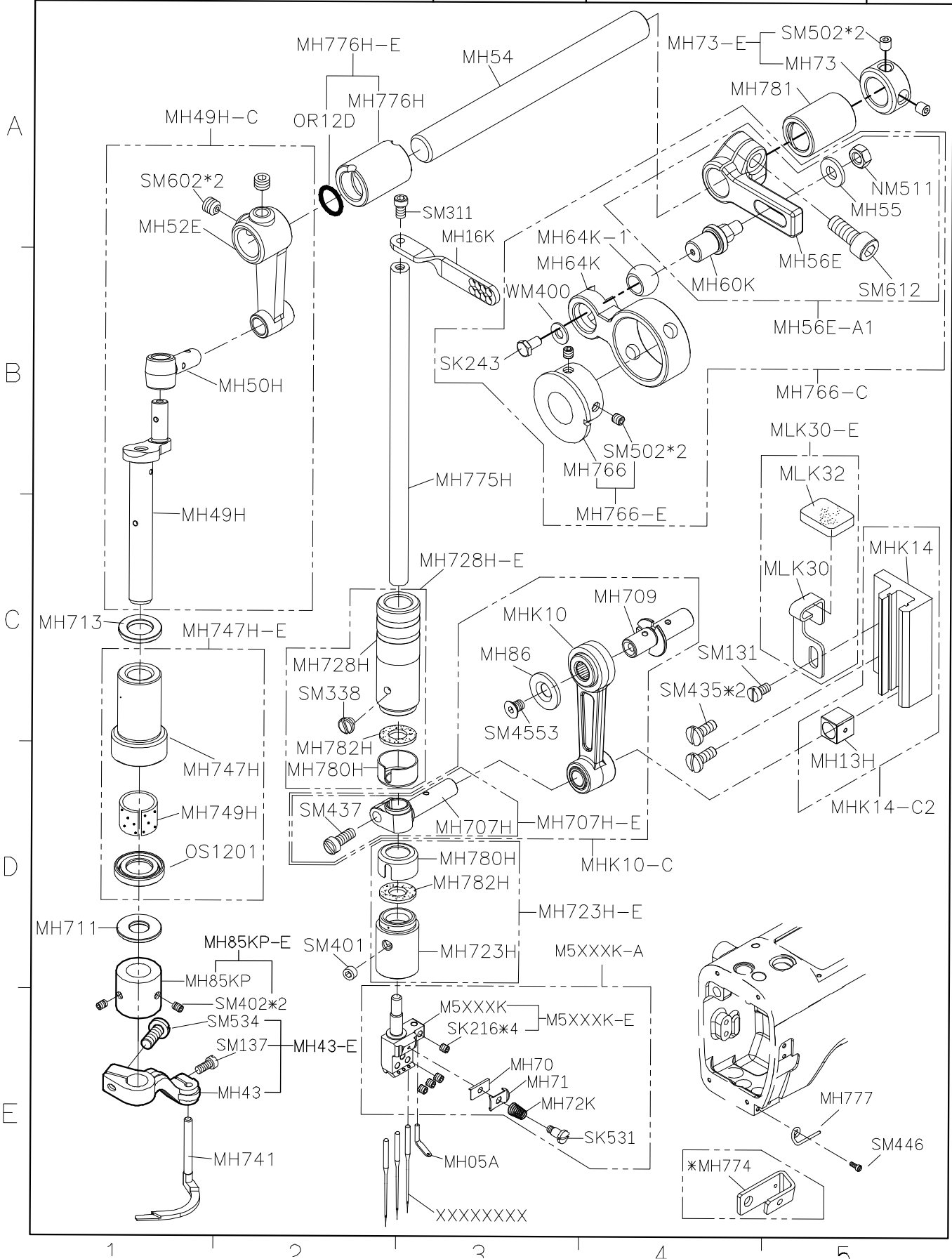



SIRUBA PARTS LIST	Series	Parts Group	Subclass / Remark	Page
	C007LX	MJ-L	*: With Direct-Drive Motor-UT	1/1
				Date
				2022/3/28

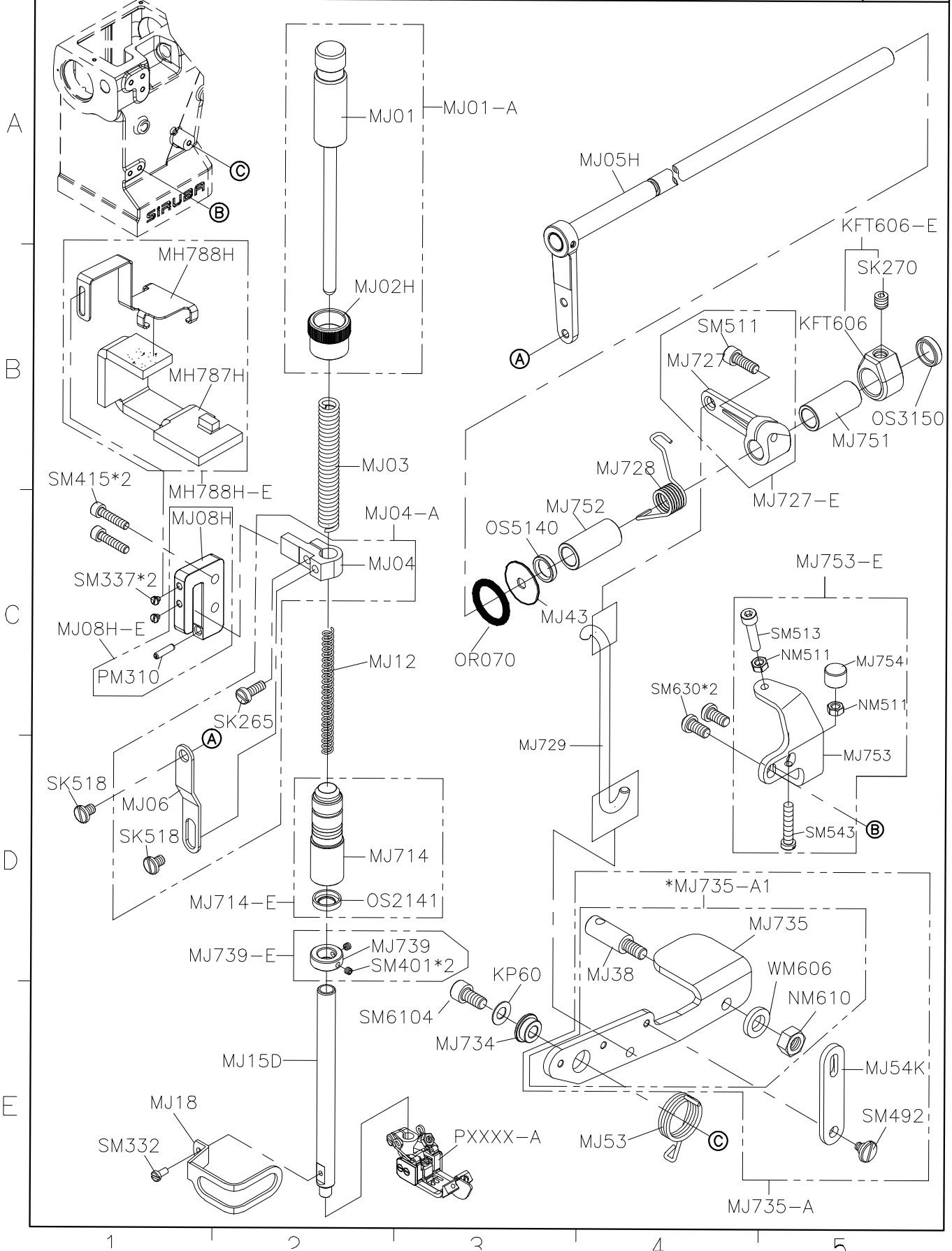

SIRUBA PARTS LIST	Series	Parts Group	Subclass / Remark	Page
	C007L/C007LX	MK-L		1/1
				Date
				2021/6/10

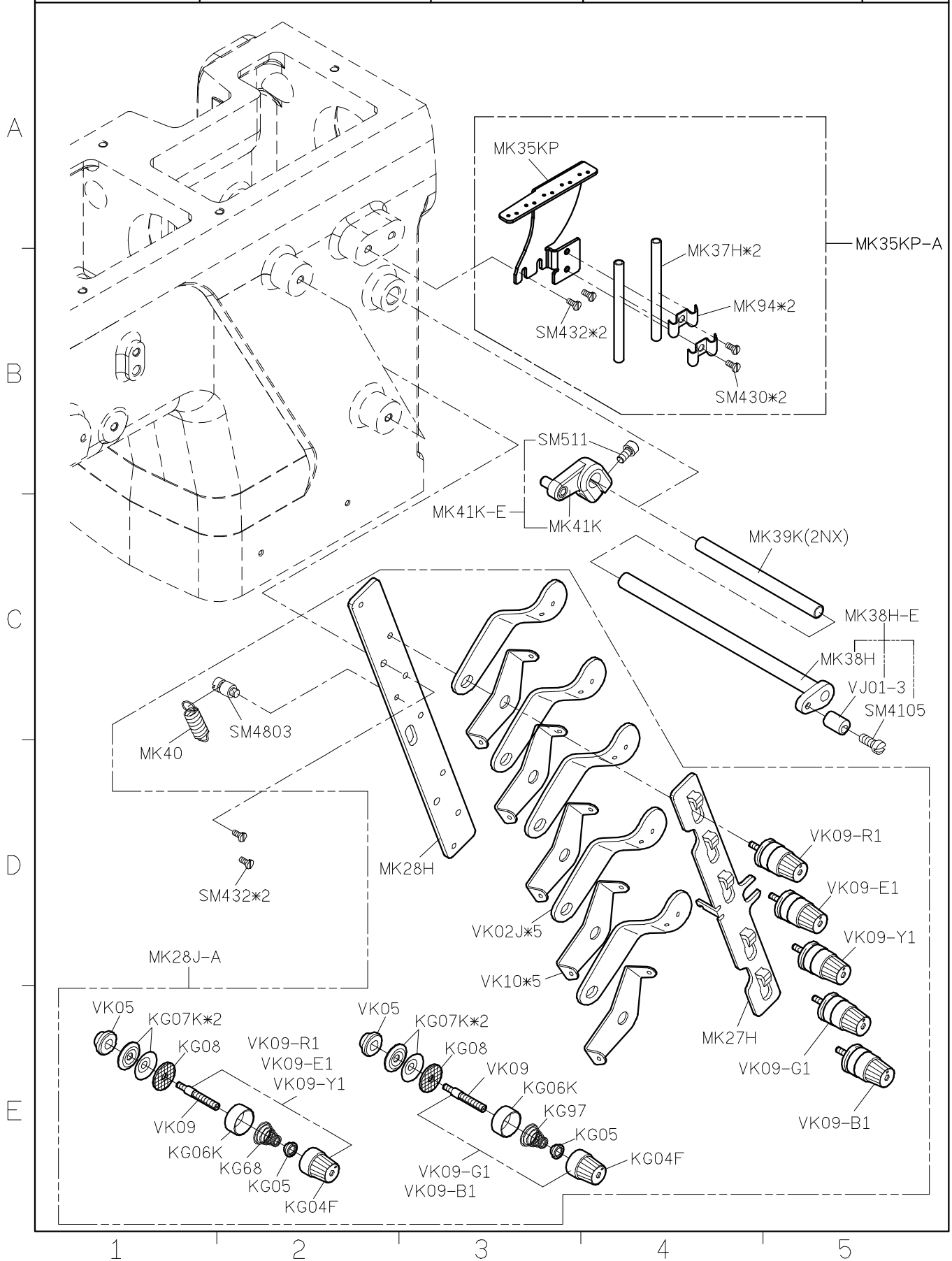

SIRUBA PARTS LIST	Series	Parts Group	Subclass / Remark	Page
	C007L/C007LX	MN-L		1/2
				Date
				2016/08/15

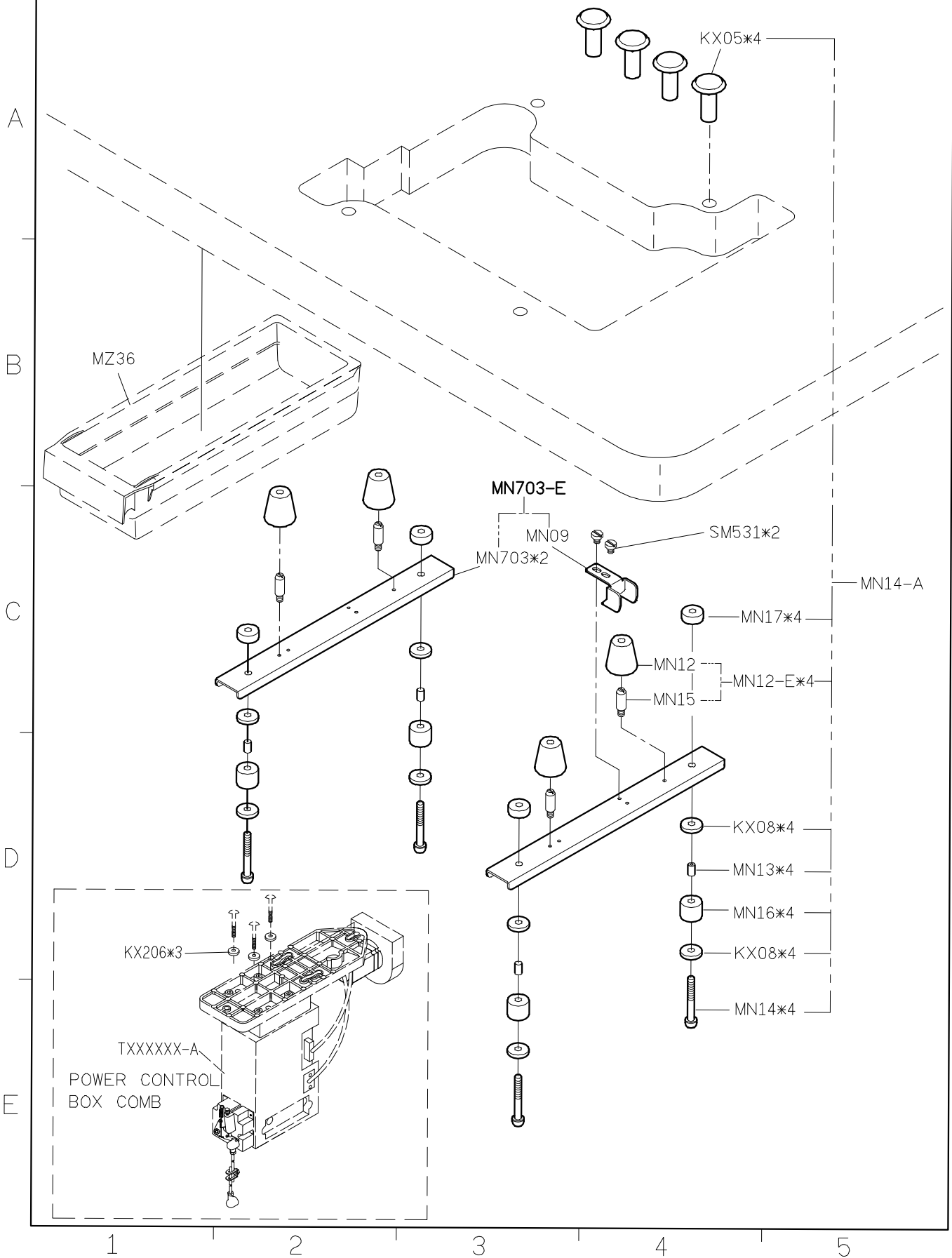

SIRUBA PARTS LIST	Series	Parts Group	Subclass / Remark	Page
	C007L/C007LX	MN-L		2/2
				Date
				2020/07/03

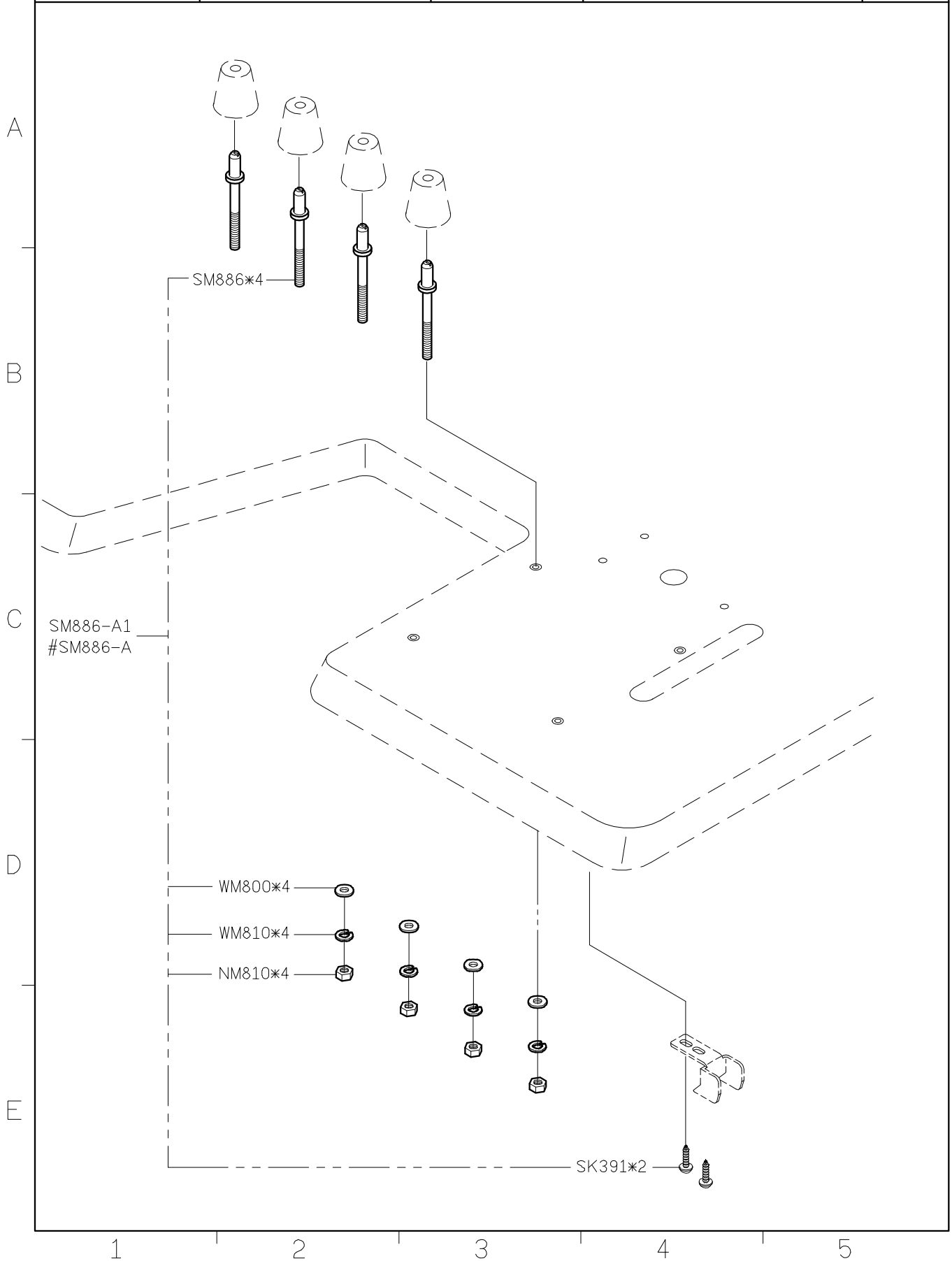

SIRUBA PARTS LIST	Series	Parts Group	Subclass / Remark	Page
	C007L/C007LX	MQ-L		1/3
				Date
				2021/8/25

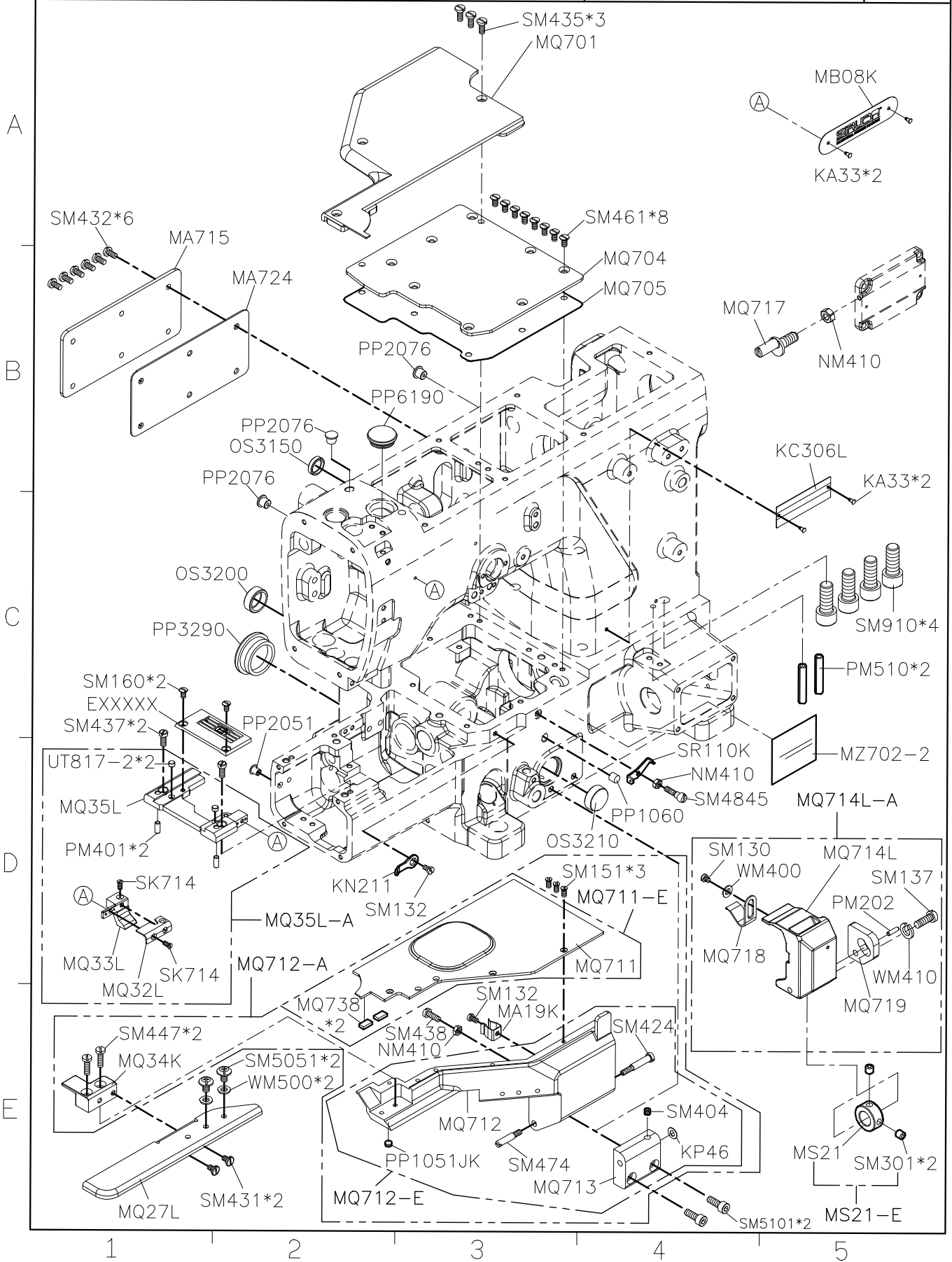

SIRUBA PARTS LIST	Series	Parts Group	Subclass / Remark	Page
	C007L/C007LX	MQ	For Direct-Drive Motor (T牌) #For Pneumatic Automatic %For Electric Automatic	2/3
				Date
				2020/11/4

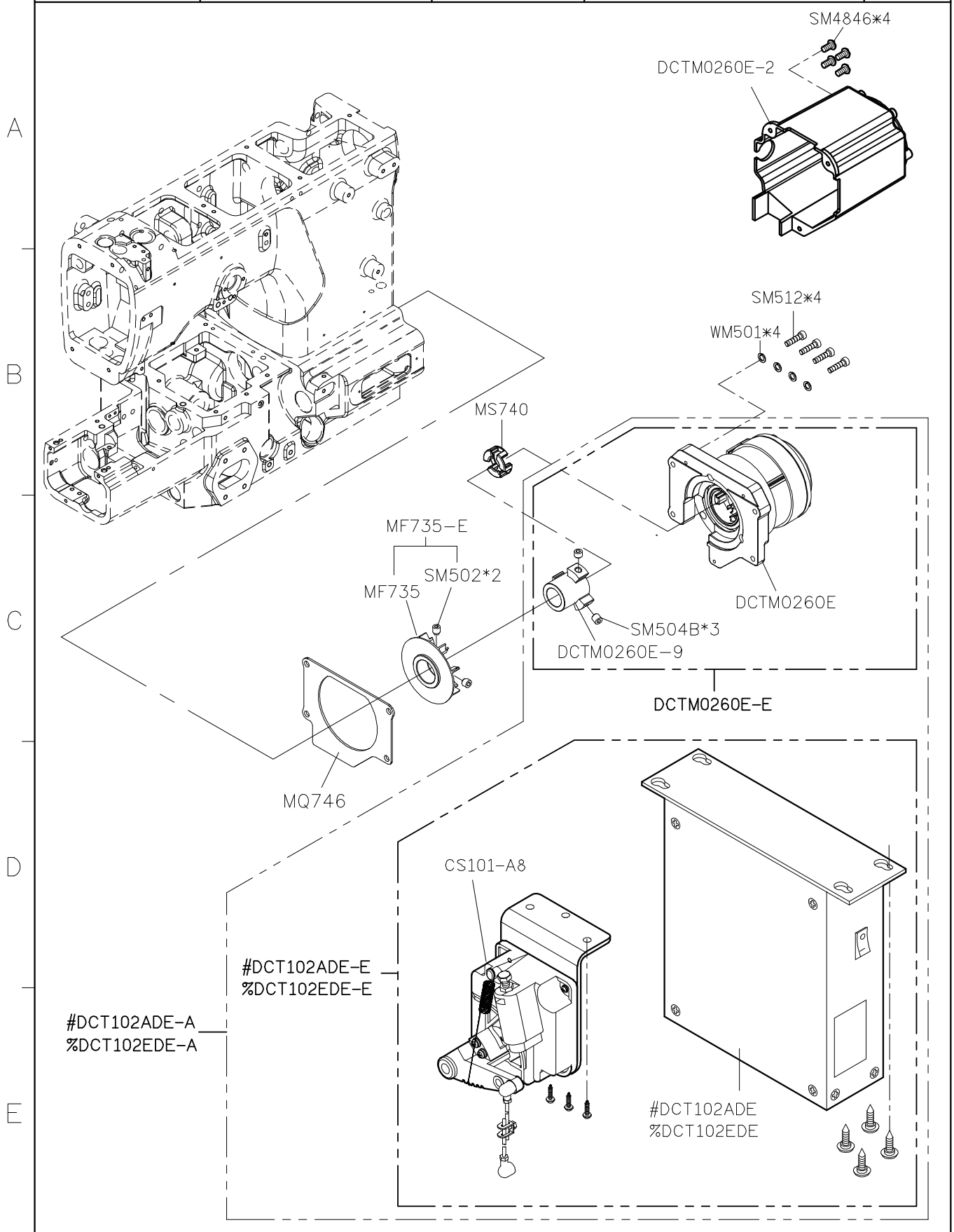

1 2 3 4 5

SIRUBA PARTS LIST	Series	Parts Group	Subclass / Remark	Page
	C007L/C007LX	MQ	For Direct-Drive Motor (H牌) #For Pneumatic Automatic %For Electric Automatic	3/3
				Date
				2020/11/4

A

B

C

D

E

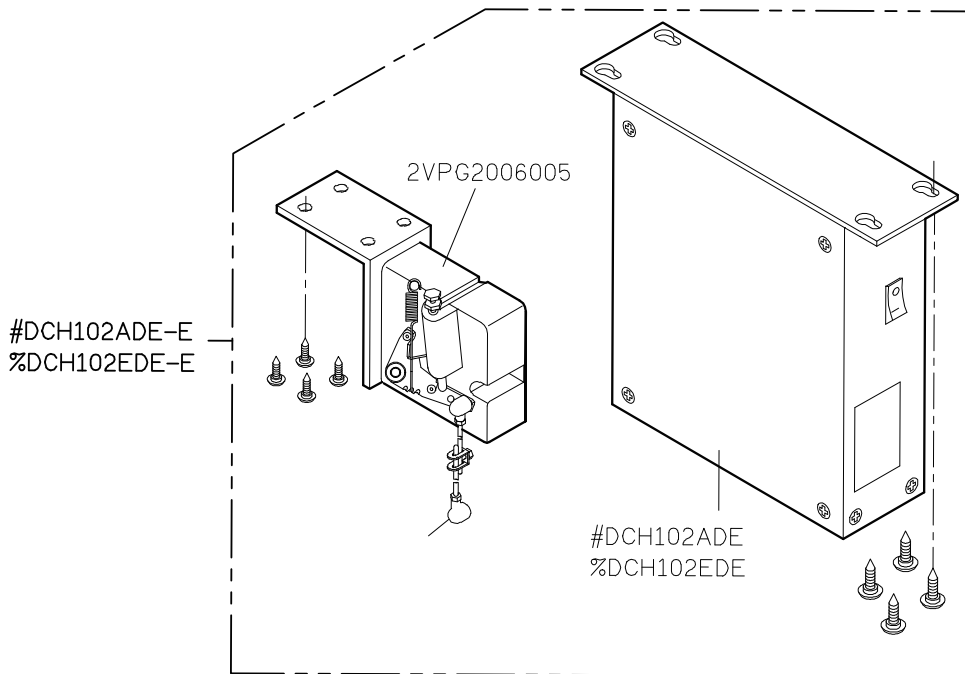
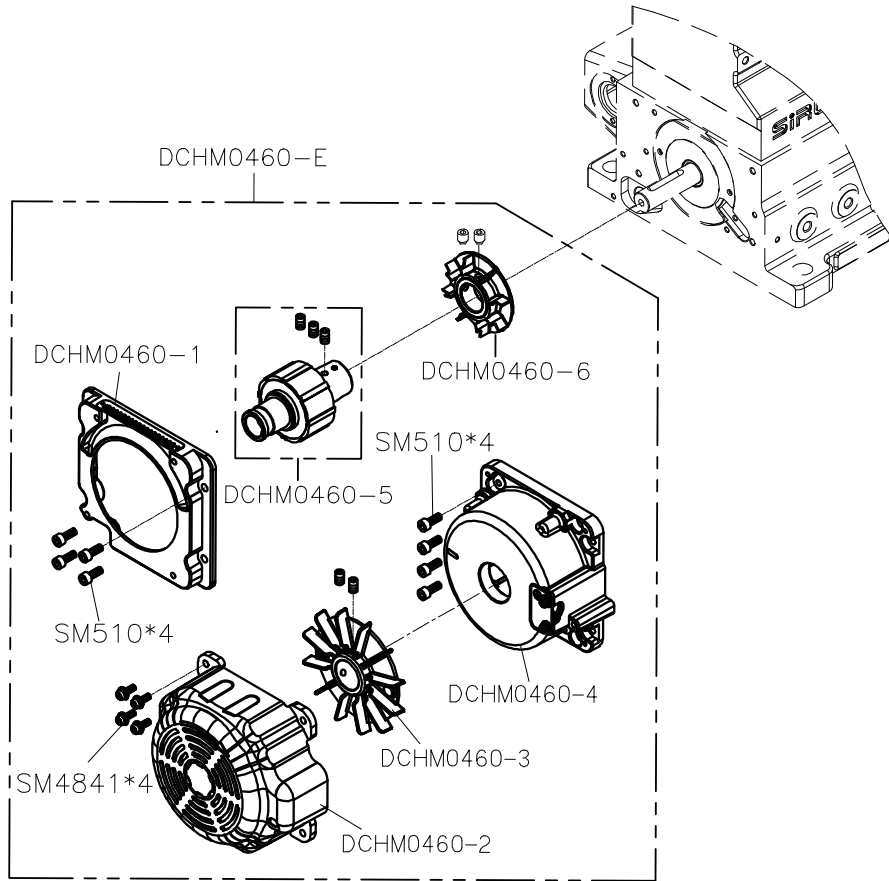

1

2

3

4

5

SIRUBA PARTS LIST	Series	Parts Group	Subclass / Remark	Page
	C007L/C007LX	MR-L	△: Use for CW *: Use for Without Direct-Drive Motor †: Use for C007LX	1/1
				Date
				2020/11/5

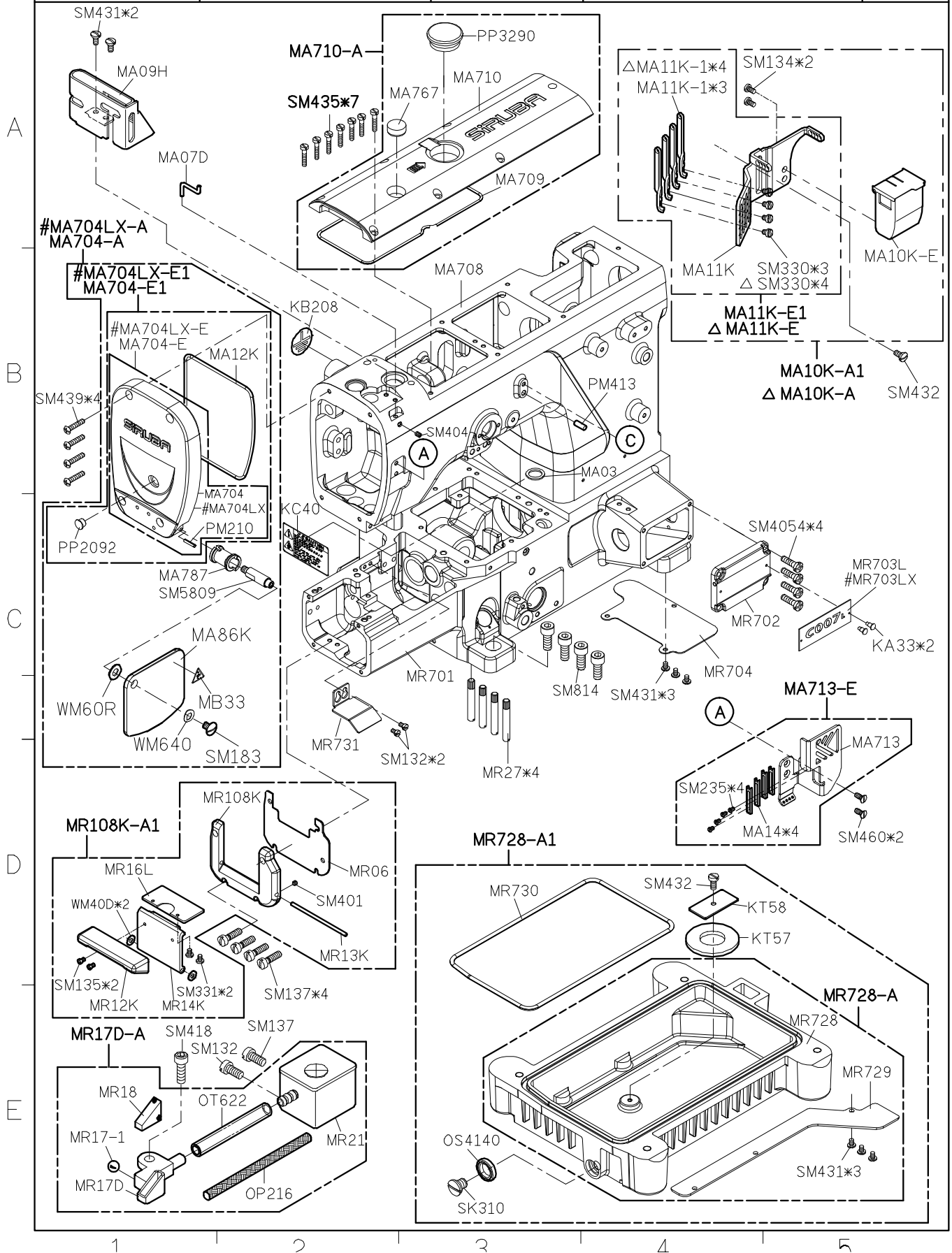



SIRUBA PARTS LIST	Series	Parts Group	Subclass / Remark	Page
	C007L/C007LX	MT-L		1/1
				Date
				2019/11/02

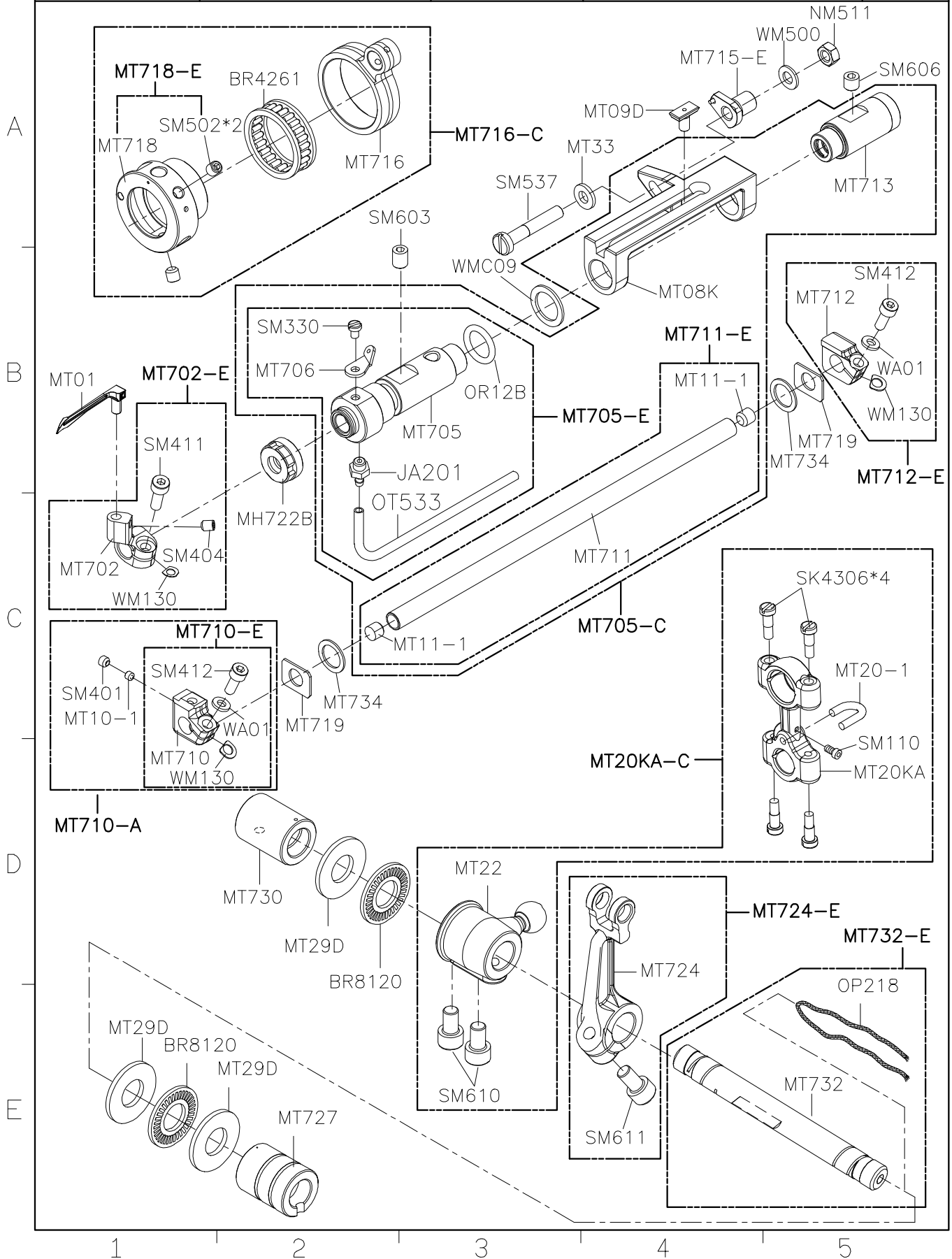



SIRUBA PARTS LIST	Series	Parts Group	Subclass / Remark	Page
	C007L/C007LX	MV-L		1/2
				Date
				2022/2/7

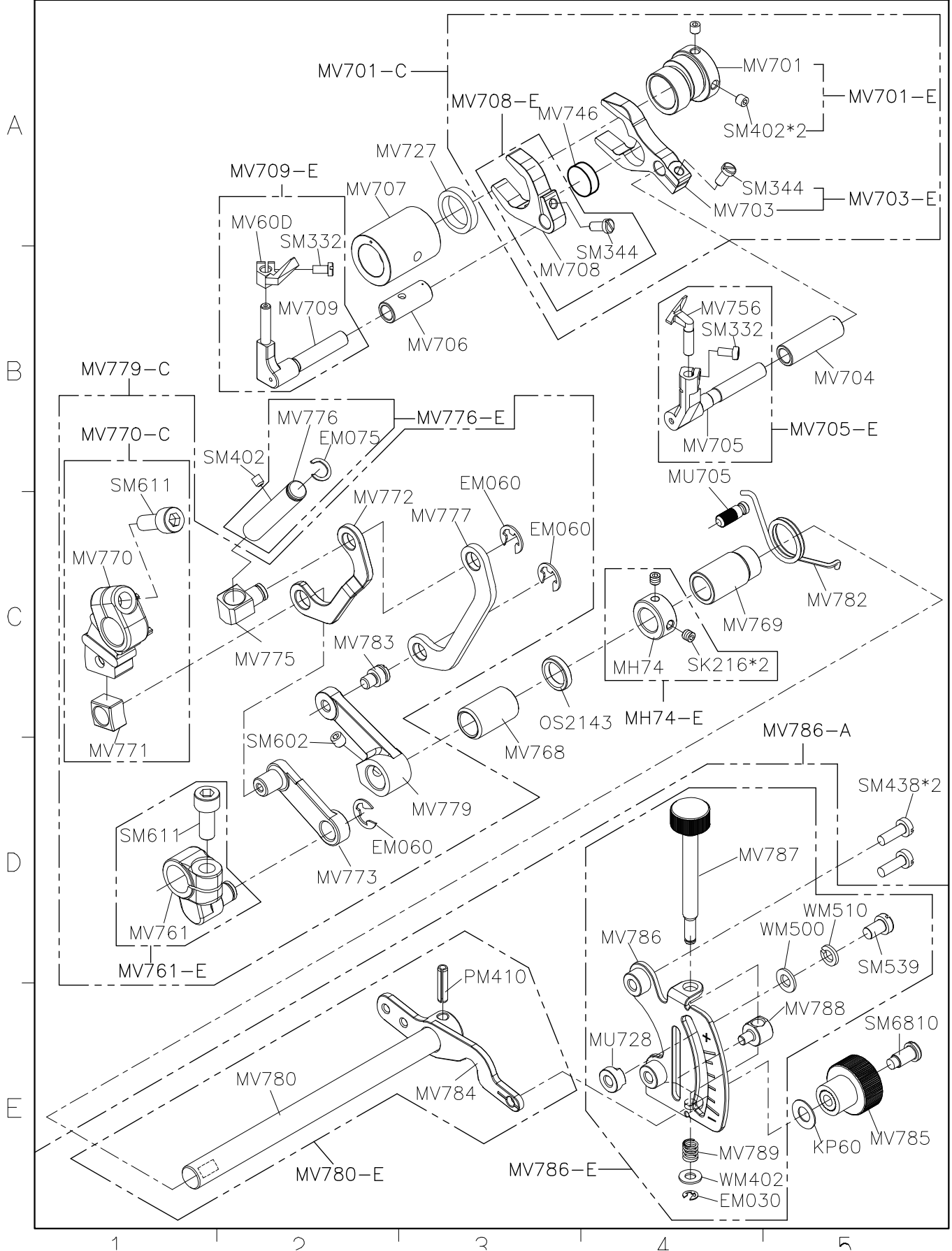

SIRUBA PARTS LIST	Series	Parts Group	Subclass / Remark	Page
	C007L/C007LX	MV-L		2/2
				Date 2022/2/7

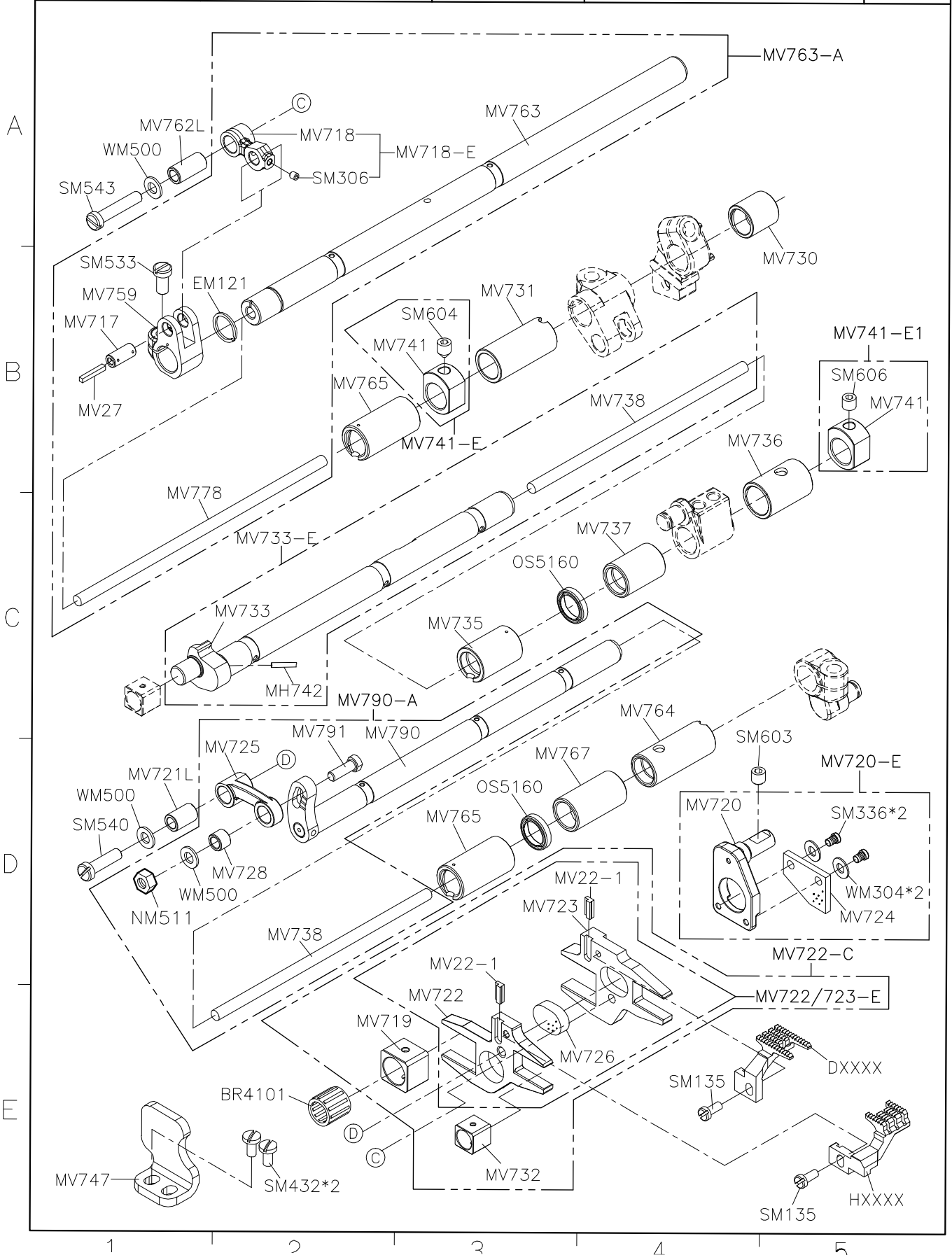

SIRUBA PARTS LIST	Series	Parts Group	Subclass / Remark	Page
	C007L	MW-L		1/1
				Date
				2021/12/22

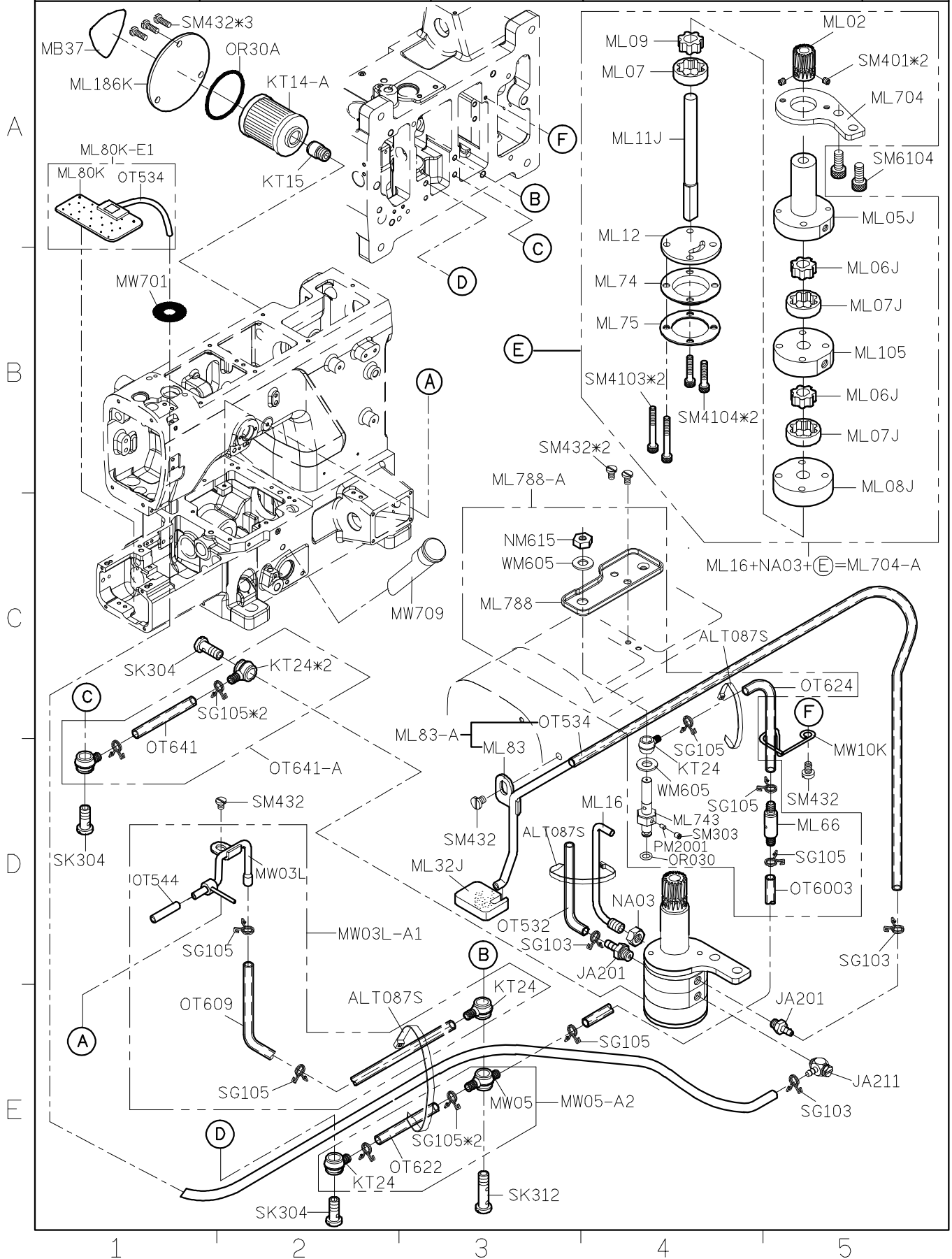

SIRUBA PARTS LIST	Series	Parts Group	Subclass / Remark	Page
	C007LX	MW-L		1/1
				Date
				2021/12/22

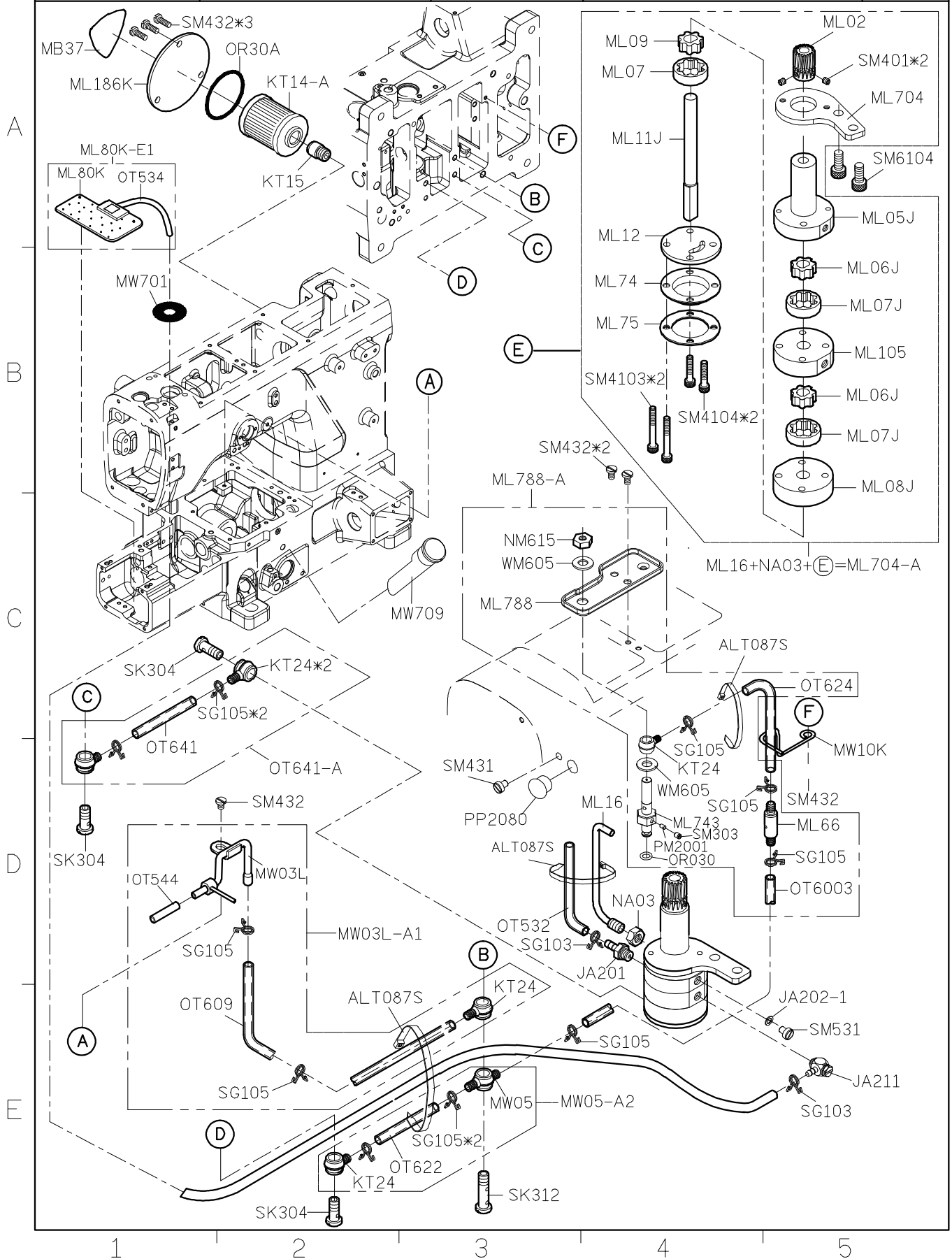

SIRUBA PARTS LIST	Series	Parts Group	Subclass / Remark	Page
	C007L/C007LX	MY-L		1/1
				Date
				2020/7/3

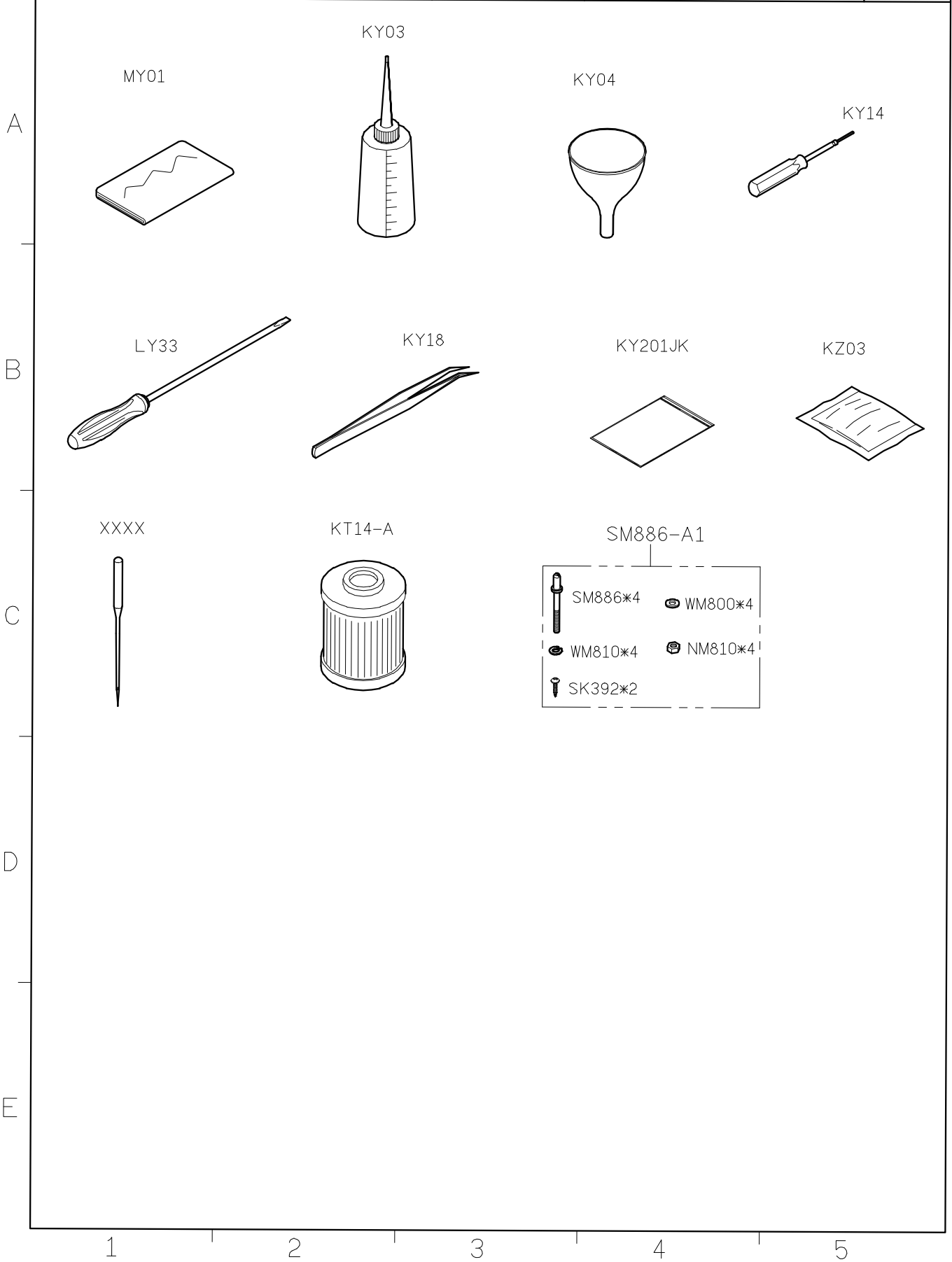

SIRUBA PARTS LIST	Series	Parts Group	Subclass / Remark	Page
	C007L/C007LX	MZ-L	Use for Drive Motor @: Use for Drive Motor+UT #:For C007LX	1/1
				Date 2020/7/3

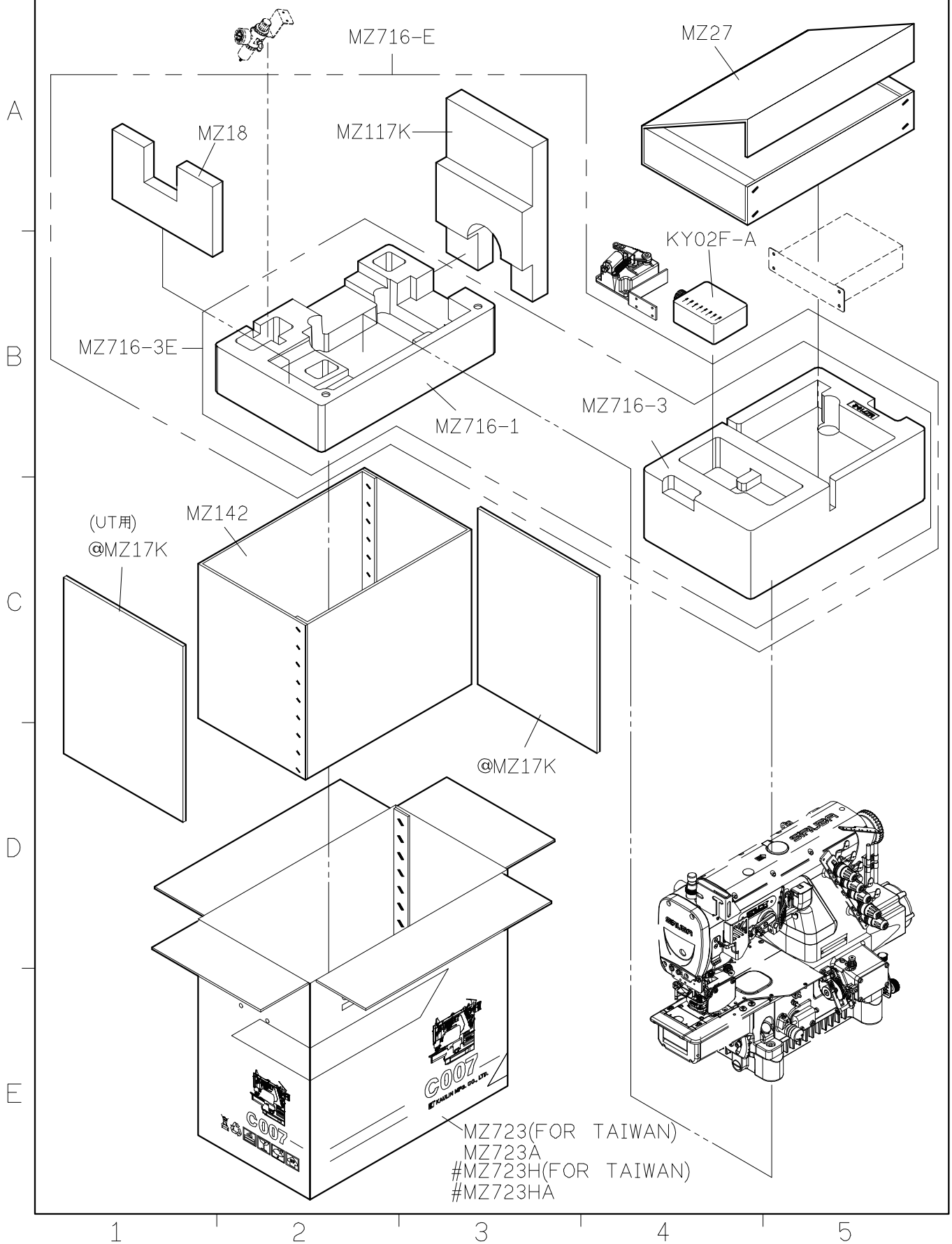



1. 當機器需要被淘汰與報廢時，有一些基本規則必須採納、遵守以保護環境及公眾健康。
  2. 所有的機器零件必須依照下列分類來區分開：
    - 開
    - (1) 所有護套、可伸縮軟管及塑膠或非金屬零件。
    - (2) 電器零件：開關、照明器具等。
    - (3) 絕緣材料：石棉、彈性 / 可伸縮橡膠片。
    - (4) 金屬：含鐵金屬、銅、青銅與黃銅、其他各種金屬。
  3. 以此方法，所有材質可以正確的淘汰，回收再利用或熔解為可再使用或再處理而不至於危害環境。  
回
1. When the machine needs to be eliminated and demolished, certain basic rules must be observed to protect the environment and public health.
  2. ALL machine components must be divided according to categories as the followings:
    - (1) All sheathes, flexible hosing and plastic or non-metal components.
    - (2) Electricity components: switches, or lighting components.
    - (3) Insulation materials: rock wool, and Flexible rubber strips.
    - (4) Metals: ferrous metals, copper, bronze and brass, various.
  3. In this way, all materials can be eliminated correctly, recycled, or melted down for reuse or disposed of so that they do not harm the environment.

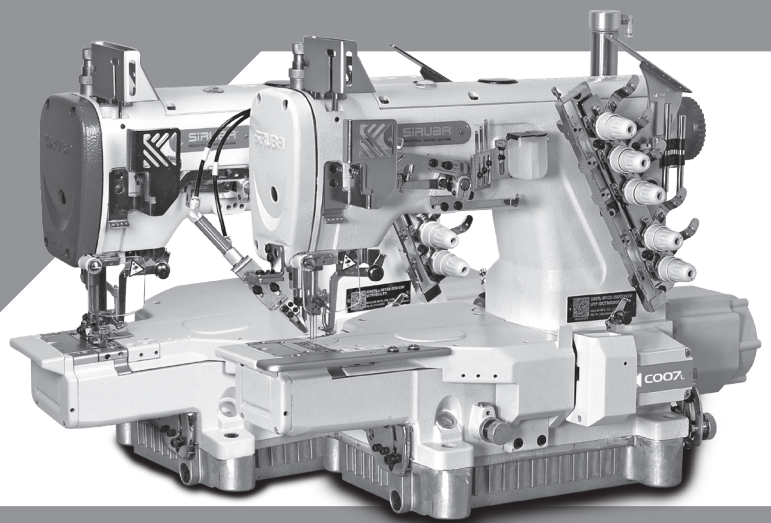

高林股份有限公司  
KAULIN MFG. CO., LTD.

由於對產品的改良及更新，本產品使用說明書中與零件圖之產品及外觀的修改恕不事先通知！  
The specification and/or appearances of the equipment described in this instruction book & parts list are subject to change because of modification which will without previous notice.  
MY727K.MAY.2022