

SIRUBA

使用說明書與零件圖

INSTRUCTIONS BOOK & PARTS LIST

DL7500-RNM1

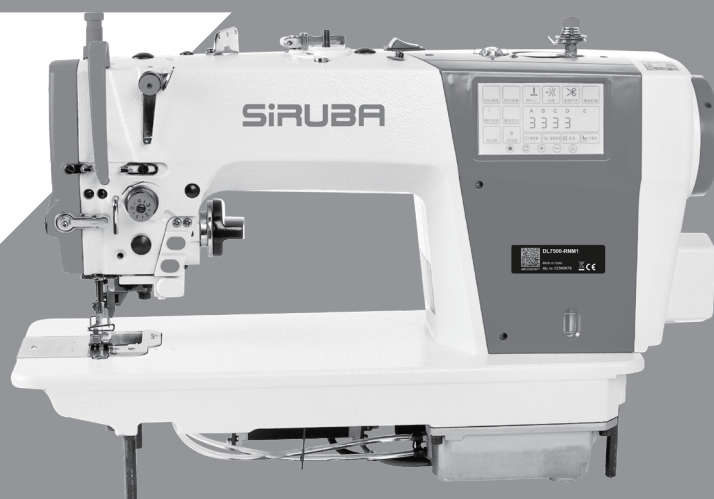

重要安全事項

為使您正確使用我們的產品，須對產品的各種功能充分了解，以便安全操作。使用前請仔細閱讀使用說明書。我們希望您能長期愉快地使用我們的產品，請保存好說明書，以備查閱。

1. 使用此縫紉機時，必須遵守包括如下項目的基本安全措施。
2. 使用此縫紉機之前，請閱讀本使用說明書在內的所有指示文件。
同時應將此使用說明書妥善保管，以便能夠隨時查閱。
3. 此縫紉機應與貴國的有關安全規定一起使用。
4. 使用此縫紉機和縫紉機動作中，所有的安全裝置應安裝到規定的位置。
沒有安裝規定的安全裝置的縫紉機禁止使用。
5. 此縫紉機應由接受過培訓的操作人員來操作。
6. 使用縫紉機時，建議戴安全防護眼鏡。
7. 發生下列情況時，應立即關掉電源開關，或拔下電源插頭。
 - 7-1 機針、彎針、分离器穿線和更換旋梭時。
 - 7-2 更換機針、壓腳、針板、彎針、分离器、送布牙、護針器、支架向導器等時。
 - 7-3 修理時。
 - 7-4 工作場所無人了或離開工作場所時。
8. 縫紉機以及附屬裝置使用的機油、潤滑脂等液體流入眼睛或沾到皮膚上時，或被誤飲時，應立即清洗有關部分
並去醫院治療。

9. 禁止用手觸摸打開了縫紉機開關通電的零件或裝置。
10. 有關縫紉機的修理、改造、調整應由受過專門訓練的技術人員或專家進行。
11. 一般的維修保養應由受過訓練的人員來進行。
12. 有關縫紉機的電氣方面的修理、維修應由資格的電氣技術人員或專家的監督和指導下進行。
13. 修理、保養有關空氣、氣缸等壓縮空氣的零件時，應切斷空氣壓縮機供氣源后再進行。如有殘留壓縮空氣時，
應放掉壓縮空氣。
14. 縫紉機在其使用其間應定期清掃。

15. 為了正常安全運轉，應安裝地線。同時應在不受高頻焊接機等強噪音源影響的環境下使用。
16. 電源插頭應用具有電氣專門知識來安裝。電源插頭必須連接到接地插座上。

17. 縫紉機指定用途以外不能使用。
18. 對縫紉機的改造、變更應符合安全規格，並採取有獎的安全措施。
另外，對於有關改造和變更，公司概不負責。

19. 本使用說明書上採用以下2個警告符號。



有損傷操作人員、維修人員的危險。



安全上需要特別加以注意的事項。

IMPORTANT SAFETY INSTRUCTIONS

To get the most out of the many functions of this machine and operate it in safety, it is necessary to use this machine correctly. Please read this instruction Manual carefully before use. We hope you will enjoy the use of your machine for a long time. Please remember to keep this manual in a safe place.

1. Observe the basic safety measures, including, but not limited to the following ones, whenever you use the machine.
2. Read all the instructions, including, but not limited to this Instruction Manual before you use the machine. In addition, keep this Instruction Manual so that you read it at anytime when necessary.
3. Use the machine after it has been ascertained that it conforms with safety rules/standards valid in your country.
4. All safety device must be in position when the machine is ready for word or in operation.
The operation without the specified safety devices is not allowed.
5. This machine shall be operated by appropriately-trained operators.
6. For your personal protection, we recommend that you wear safety glasses.
7. For the following, turn off the power switch or disconnect the power plug of the machine from the receptacle.
 - 7-1 For threading needle(s), looper, spreader etc. And replacing bobbin.
 - 7-2 For replacing part(s) of needle, presser foot, throat plate, looper, spreader, feed dog, needle guard, folder, cloth guide ect.
 - 7-3 For repair work.
 - 7-4 When leaving the work place or when the working place is unattended.
8. If you should allow oil, grease, etc. Use with the machine and devices to come in contact with your eyes or skin or swallow any of such liquid by mistake, immediately wash the contacted areas and consult a medical doctor.

9. Tampering with the live parts and devices, regardless of whether the machine is powered, is prohibited.
10. Repair, remodeling and adjustment works must only be done by appropriately trained technicians or specially skilled Personnel. Only spare parts designated by can be used for repairs.
11. General maintenance and inspection works have to be done by appropriately trained personnel.
12. Repair and maintenance works of electrical components shall be conducted by qualified electric technicians or under the audit and guidance of specially skilled personnel.
13. Before making repair and maintenance works on the machine equipped with pneumatic parts such as an air cylinder, he air compressor has to be detached from the machine and the compressed air supply has to be cut off. Existing residual air pressure after disconnecting the air compressor from the compressed air supply has to be expelled. Exceptions to this are only adjustments and performance checks done by appropriately trained technicians or specially skilled personnel.
14. Periodically clean the machine throughout the period of use.

15. Grounding the machine is always necessary for the normal operation of the machine. The machine has to be operated in an environment that is free from strong noise sources such as high-frequency welder.
16. An appropriate power plug has to be attached to the machine by electric technicians. Power plug has to be connected to a grounded receptacle.

17. Grounding the machine is always necessary for the normal operation of the machine. The machine has to be operated in an environment that is free from strong noise sources such as high-frequency welder.
18. An appropriate power plug has to be attached to the machine by electric technicians. Power plug has to be connected to a grounded receptacle.

19. Warning hints are marked with the two shown symbols.





Danger of injury to operator or service staff



Items requiring special attention

安全操作事項

FOR SAFE OPERATION

 <p>危險 DANGER</p>	<ol style="list-style-type: none"> 1. 為了防止发生觸電事故，請不要再打開電源的狀態下，打開電氣箱蓋以及觸摸電氣箱內的零件。 1. To avoid electrical shock hazards, neither open the cover of the electrical box for the motor nor touch the components mounted inside the electrical box.
 <p>注意 CAUTION</p>	<ol style="list-style-type: none"> 1. 為了防止人身事故的发生，請不要再卸下電機罩、手指防護器等安全裝置的狀態下運轉縫紉機。 2. 為了防止被卷入機器的人身事故，縫紉機運轉中請不要將手指、頭發、衣服靠近手輪、也不要把東西放到機器上面 3. 為了防止人身事故的发生，打開電源時以及縫紉機運轉中，請不要把手指放到機針附近。 4. 為了防止人身事故的发生，縫紉機運轉中請不要反手指放到挑線杆外罩內。 5. 縫紉機操作中，旋梭高速地旋轉。為了防止手受到傷害，運轉中請絕對不要把手靠近旋梭。 6. 為了防止人身事故的发生，放到縫紉機或返回原來位置時，要注意不要夾住手。 7. 為了防止突然的起動造成人身事故，放到縫紉機時，請一定關掉電源。 8. 使用伺服電機時，縫紉機停止電機無聲音。為了防止意外的起動造成人身事故，請注意不要忘記關電源。 9. 為了防止觸電事故，卸下電源地線的狀態，請不要運轉縫紉機。 10. 為了防止觸電和損壞電氣零件，拔電源的插頭時，請先關掉機器電源開關。 <ol style="list-style-type: none"> 1. To avoid personal injury, never operate the machine with any of the belt cover, finger guard or safety devices removed. 2. To prevent possible personal injuries caused by being caught in the machine, keep your fingers, head and clothes away from the handwheel, V belt and the motor while the machine is operation. In addition, place nothing around them. 3. To avoid personal injury, never put your hand under the needle when you turn "ON" the power switch or operate the machine. 4. To avoid personal injury, never put your fingers into the thread take-up cover while the machine is operation. 5. The hook rotates at a high speed while the machine is in operation. To prevent possible injury to hands, be sure to Keep your hands away from the vicinity of the hook during operation. In addition, be sure to turn OFF the power to the machine when replacing the bobbin. 6. To avoid possible personal injuries, be careful not to allow your fingers in the machine when tilting/raising the machine head. 7. To avoid possible accidents because of abrupt start of the machine, turn OFF the power to the machine when tilting the machine head. 8. If your machine is equipped with a servo-motor does not produce noise while the machine when tilting the machine head. 9. To avoid electrical shock hazards, never operate the sewing machine with the ground wire for the power supply removed. 10. To prevent possible accidents because of electric shock or damaged electrical components(s), turn OFF the power switch in prior to the connection/disconnection of the power plug.

運轉縫紉機前的注意事項 BEFORE OPERATION



注意
CAUTION

為了防止機械錯誤動作或損傷，請確認如下項目。

To avoid malfunction and damage of the machine, confirm the following.

- 最初使用縫紉機之前，請把機器打掃干淨。
- 清除運送中積存的灰塵，并加油。
- 請確認電壓是否正確。
- 請確認電源插頭是否正確接連。
- 電壓規格不同時，請絕對不要使用。
- 縫紉機的轉動方向是，站在飛輪側看為逆時針方向。請注意不要讓縫紉機反向轉動。
- Before you put the machine into operation for the first time after the set up, clean it thoroughly.
- Remember all dust gathering during transportation and oil it well.
- Confirm that the power plug has been properly connected to the power supply.
- Never use the machine in the state where the connected to the power supply.
- The direction of rotation of the sewing machine is counterclockwise as observed from the handwheel side. Be careful not to rotate it in reverse direction.

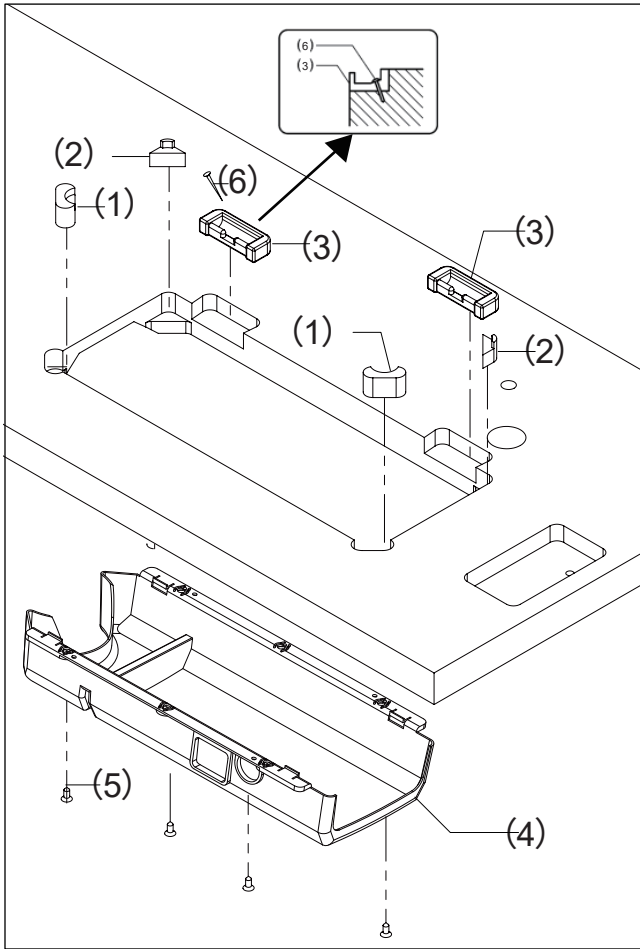

3. 安裝

- (1) 頭部防震墊 (大) (2個)
- (2) 頭部防震墊 (小) (2個)
- (3) 鉸鏈套 (2個)
- (4) 托盤
- (5) 螺釘 (4個)
- (6) 釘 (8個)

3. Install

- (1) Head cushions(big)[2 pcs]
- (2) Head cushions(small)[2 pcs]
- (3) Rubber cushions[2 pcs]
- (4)Tray
- (5) Screw [4 pcs]
- (6) Nail [8 pcs]

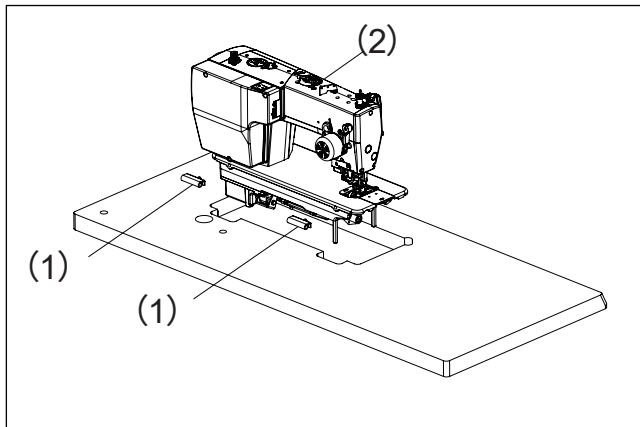

4. 縫紉機頭部

- (1) 機頭鉸鏈 (2個)
- (2) 縫紉機頭部

4. Machine head

- (1) Hinges [2 pcs]
- (2) Machine head

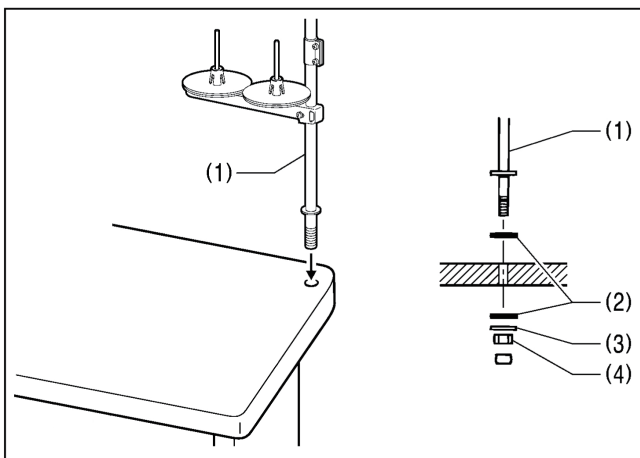

5. 線架

- (1) 線架

注意：將螺母 (4) 擰緊以便將兩個橡皮墊片 (2) 和墊圈 (3) 夾緊，使線架 (1) 固定。

5. Cotton stand

- (1) Cotton stand

NOTE:

Securely tighten the nut(4) so that the two rubber cushions(2) and the washer(3) are securely clamped and so that the cotton stand(1) does not move.

2 加油方法 Lubrication

注意 CAUTION



在加油未完成前，請勿插上電源。
當誤踩下踏腳板時，縫紉機動作會導致人員受傷。



使用潤滑油時，請務必戴好保護眼鏡和保護手套等，以防潤滑油落入眼中或沾在皮膚上，這是引起發炎的原因。
另外，潤滑油不能飲用，否則會引起嘔吐和腹瀉。
將油放在兒童拿不到的地方。



在剪去油罐的油嘴口時，請一定要拿住油嘴的根部。
如果拿住油嘴口，剪刀容易傷到手，成為受傷的原因。



Do not connect the power cord until lubrication has been completed, otherwise the machine may operate if the treadle is depressed by mistake, which could result in injury.



Be sure to wear protective goggles and gloves when handling the lubricating oil and grease, so that they do not get into your eyes or onto your skin, otherwise inflammation can result.
Furthermore, do not drink the oil or eat the grease under any circumstances, as they can cause vomiting and diarrhea.
Keep the oil out of the reach of children.



When cutting the nozzle of the oil tank, hold the base of the nozzle securely.
If you hold the end of the nozzle, injury from the scissors may result.

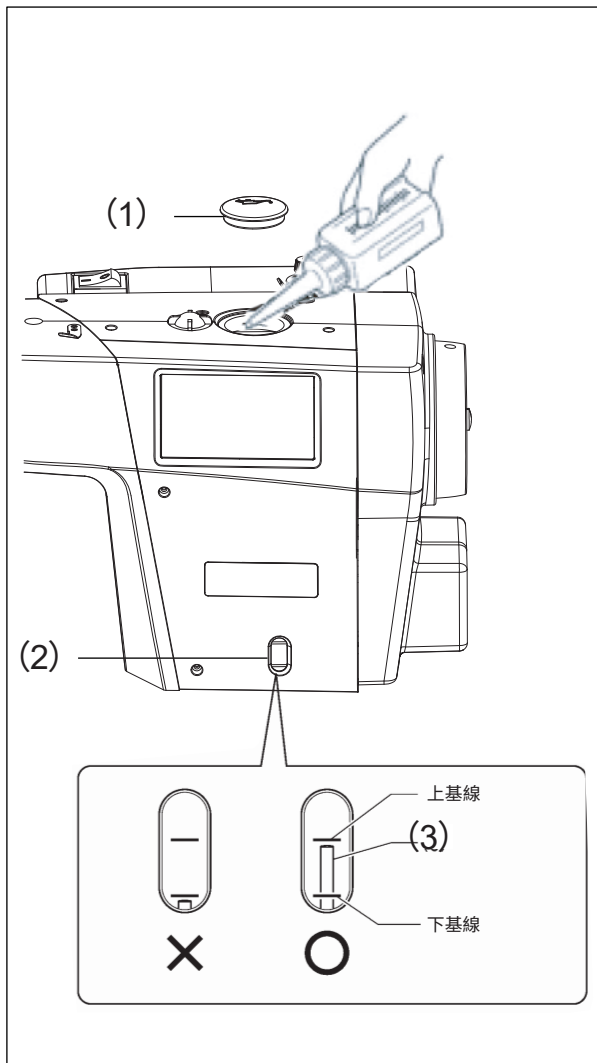

初次使用縫紉機前需添加機油以保證機器各部機械部件的潤滑，以延長機器壽命

1. 將加注機油孔塞(1) 打開
2. 將白油注入機頭加油口中
3. 加油過程中觀察油量視窗(2)，使油量計(3) 穩定在上、下基線之間

注：油量計不可超過視窗上基線

如油量計(3) 低于下基線，則必須添加機油

Before the first time use this sewing machine, you need to add oil to ensure the lubrication of the mechanical parts of the machine, to prolong the service life of the machine

1. open the oil rubber (1)
 2. add oil into the machine
 3. look at the oil window (2) during adding oil, to make the oil gauge (3) is steable between the top and bottom baselines
- Note: the oil guage can't be over the top baseline in the window

If the oil gauge (3) is lower than the buttom baseline, machine must be added oil

3.面線的穿法 THREADING THE UPPER THREAD

注意 CAUTION



在穿線過程中，請切斷電源。當誤按動起動開關時，縫紉機動作會導致人員受傷。

Turn off the power switch before threading the upper thread.

The machine may operate if the treadle is depressed by mistake, which could result in injury.

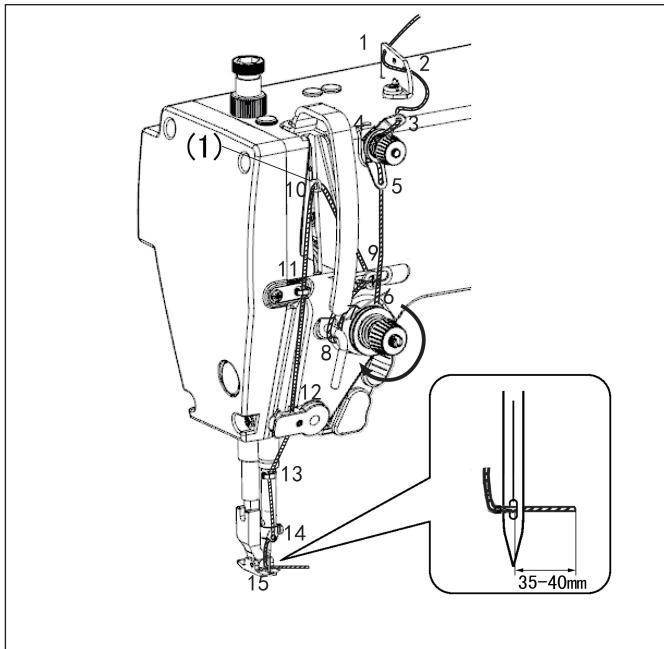

·在穿引面線之前轉動手輪，抬高挑線杆(1)。
這樣會使穿引更加容易，并防止面線在縫紉開始時脫落

·Turn the machine pulley and raise the thread take-up(1) before threading the upper thread.
This will make threading easier and it will prevent the thread from coming out at the sewing start.

4.機針和旋梭的同步 Adjusting the needle and rotary hook timing

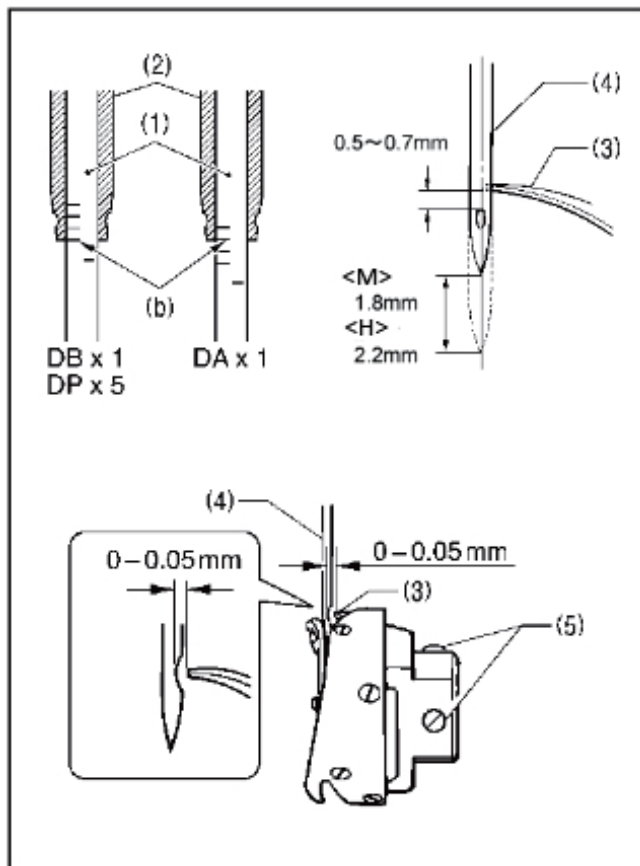

當針杆(1)從最低位置向上移動1.8mm(2.2mm用于M和H規格)，到達基線(b)與針杆軸套(2)下端對齊的位置時，旋梭尖端(3)應與機針中心(4)對齊，如圖所示。

(此時，針孔上邊緣與旋梭尖的距离為0.5至0.7mm。)

1.轉動縫紉機手輪，使針杆(1)從最低位置上升到如圖所示的基線(b)與針杆軸套(2)的下端保持對齊為止。

2.旋松固定螺釘(5)[3個]，使旋梭尖(3)與機針(4)的中心一致。

此時，旋梭尖(3)與機針(4)之間間隙為0~0.05mm

3.擰緊固定螺釘(5)[3個]。

The tip of the rotary hook (3) should be aligned with the center of the needle (4) when the needle bar (1) moves up 1.8mm (2.2mm for -M and -H specifications) from its lowest position to the position where reference line (b) is aligned with the lower edge of the needle bar bush (2) as shown in the illustration. (The distance from the upper edge of the needle hole to the rotary hook tip will be 0.5 to 0.7mm at this time.)

1. Turn the machine pulley to raise the needle bar (1) from its lowest position until reference line (b) is aligned with the lower edge of the needle bar bush D (2) as shown in the illustration.
2. Loosen the set screws (5), and then align the tip of the rotary hook (3) with the center of the needle (4).

The distance between the tip of the rotary hook (3) and the needle (4) should be approximately 0-0.05mm.

3. Securely tighten the set screws (5).

5.踏板的調整 ADJUSTMENT OF THE PEDAL



注意

為了防止意外的起動造成的事故，請關掉電源后進行。

WARNING:

Turn off the power before starting the work so as to prevent accidents caused by abrupt start of the sewing machine.

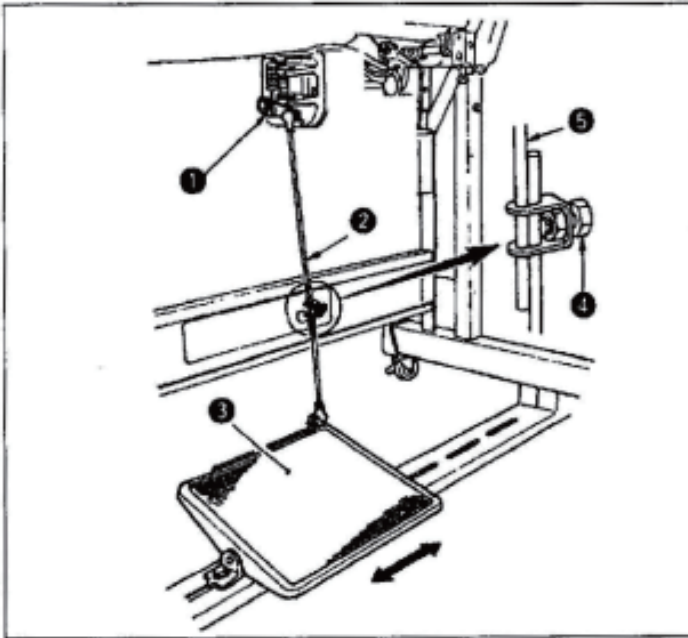

(1) 連接杆的安裝

1) 向箭頭方向移動踏板調節板③，讓踏板撥杆①和連接杆②呈一直線。

(2) 踏板的角度

1) 調節連接杆的長度就可以自由地改變踏板的傾斜角度。

2) 擰松調節螺絲④，拉出插入連接杆⑤進行調整。

(1) Installing the connecting rod

1) Move pedal ③ to the right or left as illustrated by the arrow so that motor control lever ① and connecting rod ② are straightened.

(2) Adjusting the pedal angle

1) The pedal tilt can be freely adjusted by changing the length of the connecting rod.

2) Loosen adjust screw ④, and adjust the length of connecting rod ⑤.

踏板操作 / PEDAL OPERATION

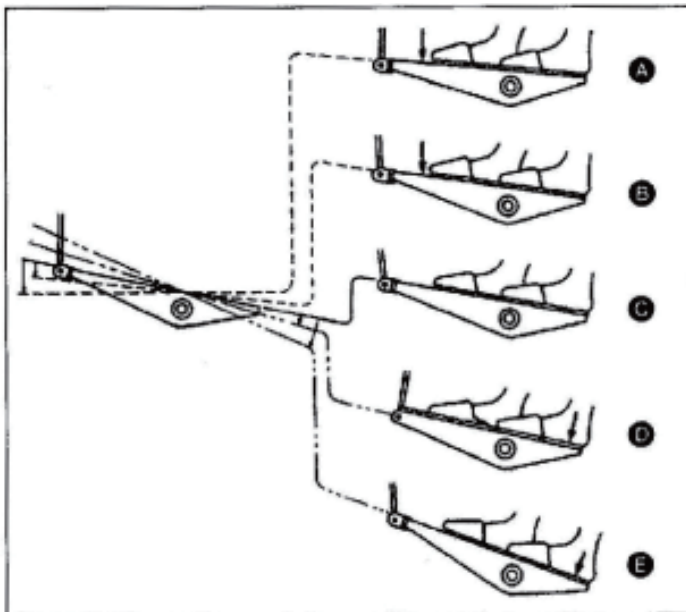

(1) 踏板按4個階段進行操作。

1) 向前輕輕踩踏板為低速縫制 (B)。

2) 再用力向前踩踏板則變為告訴縫制 (A)。(但是，開關設定為自動倒縫時，倒縫結束後進行高速縫制)

3) 把踏板返回到腳輕輕地放到踏板上的位置縫紉機停止 (C)。(機針上停止或下停止位置)

4) 用力向后踩踏板則為切線動作 (E)。

* 使用自動壓腳提升裝置時，再停止和切線之間增加1級開關。向后輕輕的踩踏板為壓腳提升動作 (D) 再往后用力踩踏板為切線動作。

(1) The pedal is operated in the following four steps:

1) The machine runs at low sewing speed when you lightly depress the front part of the pedal (B).

2) The machine runs at high sewing speed when you lightly depress the front part of the pedal (A).

(If the automatic reverse feed stitching has been preset, the machine runs at high speed after it completes reverse feed stitching)

3) The machine stops (with its needle up or down) when you reset the pedal to its original position (C).

4) The machine trims threads when you fully depress the back part of the pedal (E).

* If your machine is provided with the Auto-lifter an addition step is given between the machine stop and thread Trimming step. The presser foot goes up when you lightly depress the back part of the pedal (D), and if you further depress the back part, the thread trimmer is actuated.

6. 标准调整 STANDARD ADJUSTMENT

⚠ 注意



只有經過訓練的技術人員才能進行縫紉機的維修、保養和檢查。



與電氣有關的維修、保養和檢查請委托購買商店或電氣專業人員進行。



取下的安全保護裝置，再次安裝時，請務必安裝在原位上，并檢查能否正常的發揮作用。



縫紉機頭倒下或豎起時，請用雙手進行操作。單手操作時因縫紉機的重量萬一滑落易導致受傷。



发生下列情況時，請關閉電源。并拔下電源插座。否則誤踩下踏腳板時，縫紉機動作會導致受傷。

- 檢查、調整和維修
- 更換旋梭、切刀等易損零部件



在必須接上電源開關進行調整時，務必十分小心遵守所有的安全注意事項。

⚠ CAUTION



Maintenance and inspection of the sewing machine should only be carried out by a qualified technician.



Ask your DUMA dealer or a qualified electrician to carry out any maintenance and inspection of the electrical system.



If any safety devices have been removed, be absolutely sure to re-install them to their original positions and check that they operate correctly before using the machine.



Secure the table so that it will not move when tilting back the machine head. If the table moves, it may crush your feet or cause other injuries.



Use both hands hold the machine head when tilting it back or returning it to its original position. If only one hand is used, the weight of the machine head may cause your hand to slip, and your hand may get caught.



Turn off the power switch and disconnect the power cord from the wall outlet at the following times, otherwise the machine may operate if the treadle is depressed by mistake, which could result in injury.

- When carrying out inspection, adjustment and maintenance
- When replacing consumable parts such as the rotary hook and knife

6.1. 機殼線導向R Adjusting arm thread guide R

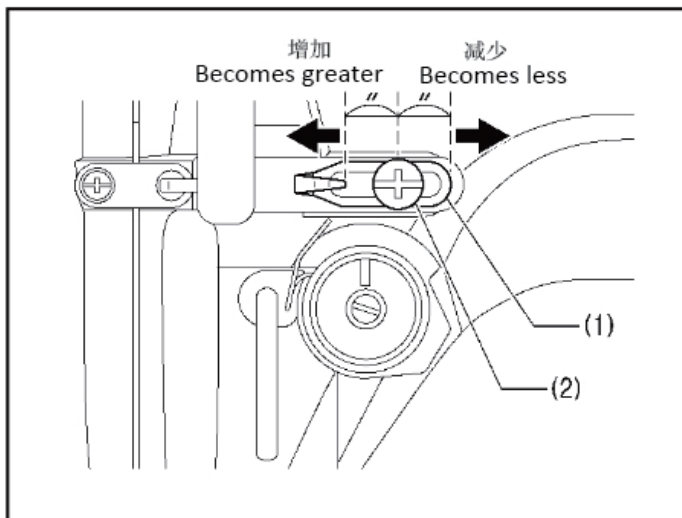

機殼線導向R(1)的标准安裝位置是在螺釘(2)位于機殼線導向R(1)的可調範圍中心處。

[注意]

旋松螺釘(2)，移動機殼線導向R(1)進行位置的調節。

- 當縫紉厚料時，向左移動機殼線導向R(1)。(挑線量增加)
- 當縫紉薄料時，向右移動機殼線導向R(1)。(挑線量減少)

The standard position of arm thread guide R (1) is the position where the screw (2) is in the center of the adjustable range for arm thread guide R (1).

To adjust the position, loosen the screw (2) and then move arm thread guide R (1).

- When sewing thick material, move arm thread guide R (1) to the left. (The thread take-up amount will become greater.)
- When sewing thin material, move arm thread guide R (1) to the right. (The thread take-up amount will become less.)

6.2 送布牙的高度

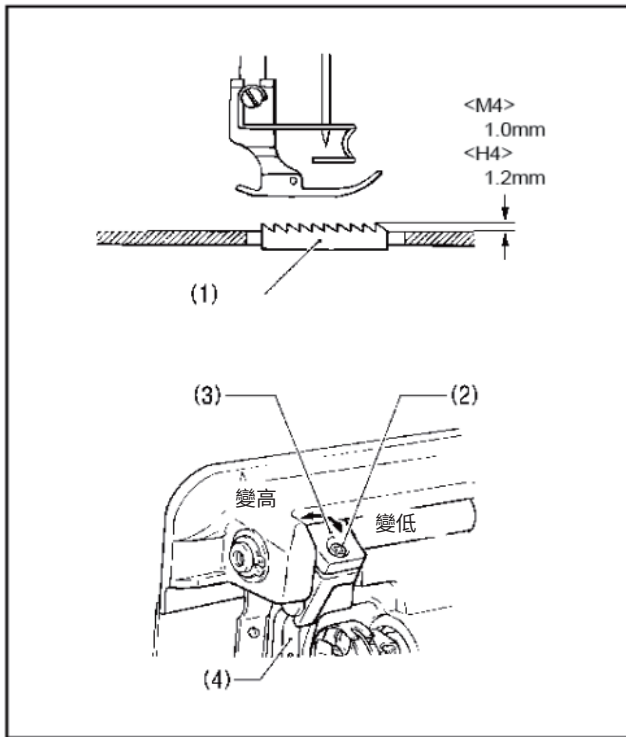

當送布牙(1)被盡量提高到針板表面之上時,其標準高度為1.0mm(用于M規格)和1.2mm(用于H規格)。

1. 回轉縫紉機手輪,將送布牙(1)移到針板上方最高處。
2. 放倒縫紉機機頭。
3. 旋松螺釘(2)。
4. 旋轉上下抬牙叉(3)來調整。
5. 擰緊螺釘(2)。

6.3 送布牙的角度

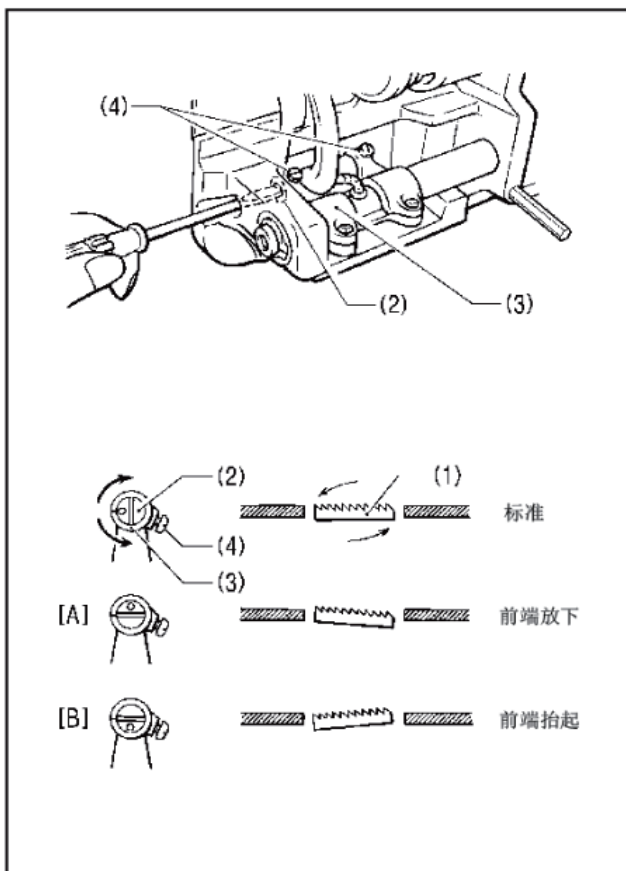

送布牙(1)位于針板最高處時的標準傾斜是牙架曲柄偏心軸(2)上的鋼印(O)與牙架曲柄(3)上的標記一致,送布牙(1)與針板平行。

1. 轉動縫紉機手輪,將送布牙(1)移到針板上方最高處的位置。
2. 放倒縫紉機機頭。
3. 將螺釘(4)[2個]松開。
4. 根據標準位置,在90°的範圍內按箭頭方向調整牙架曲柄偏心軸(2)。
 - 為了防止起皺,可降低送布牙(1)的前端。(圖A)
 - 為了防止在重疊縫紉時布料不一致[縫線不合],可抬高送布牙(1)的前端。(圖B)
5. 將螺釘(4)[2個]完全擰緊。

[注意]

調整送布牙(1)的傾斜度后,送布牙(1)的高度也會改變,因此請再一次調整送布牙(1)的高度。

6.4 Adjusting the feed dog height

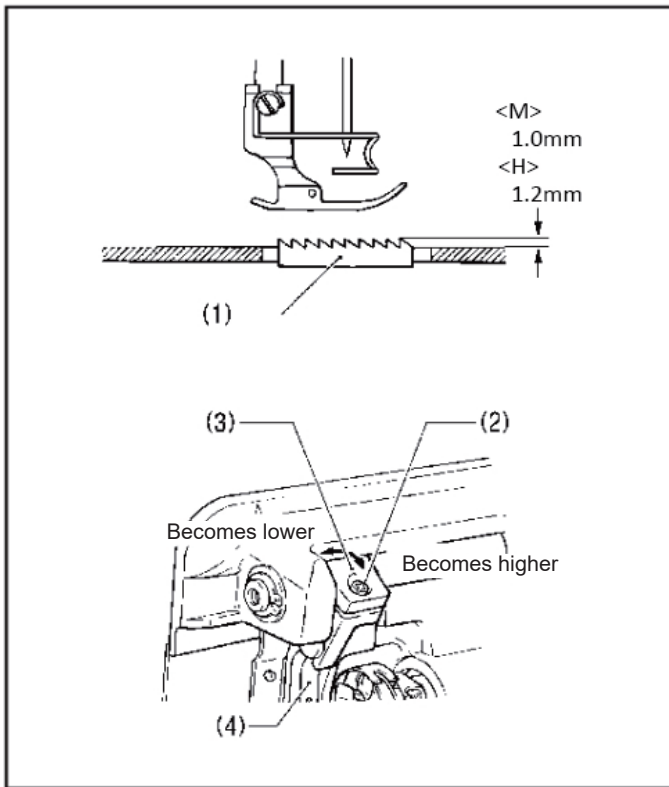

The standard height of the feed dog (1) when it is at its maximum height above the top of the needle plate is 1.0 mm for M specifications, and 1.2mm for H specifications.

1. Turn the pulley until the feed dog (1) rises to the highest Position.
2. Tilt back the machine head.
3. Loosen the screw (2).
4. Move the feed bar(3) up or down to make adjustment.
5. Tighten the screw (2).

6.5 Adjusting the feed dog angle

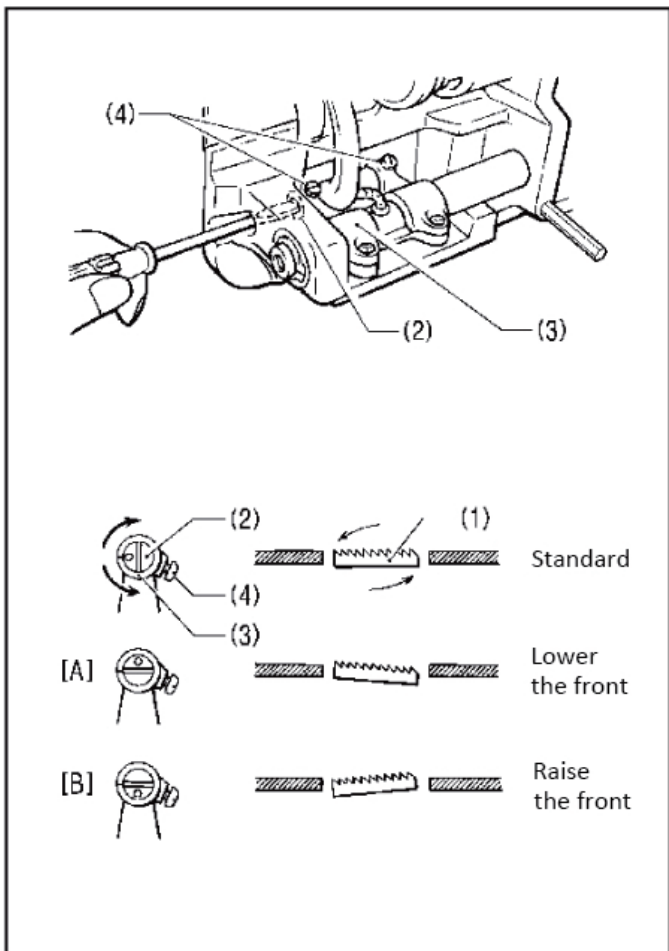

The standard angle for the feed dog (1) when it is at its highest position above the needle plate is when the “O” mark on the shaft (2) is aligned with the feed rocker bracket arm (3) and the feed dog (1) is parallel to the needle plate.

1. Make the machine hand wheel backward, rise the feed dog from lowest position to the same position with needle plate.
2. Tilt back the machine head.
3. Loosen the two set screws (4).
4. Turn the shaft (2) in the direction of the arrow within a range of 90 with respect to the standard position. (Fig.[C])
In order to prevent puckering, lower the front of the feed dog (1).
In order to prevent the material from slipping, raise the front of the feed dog (1).
5. Securely tighten the set screws (4),

7. 線張力的調節 Adjusting the thread tension

⚠ 注意 CAUTION

取出梭芯套時，請切斷電源。



當誤踩下踏腳板時，縫紉機動作會導致人員受傷。

Turn off the power switch before removing or inserting the bobbin case.

The machine may operate if the treadle is depressed by mistake, which could result in injury.

正確的針迹 Good even stitches



	<p>面線張力過小或底線張力過大。 Upper thread tension too weak Lower thread tension too strong</p>	<p>增大面線張力。減小底線張力。 Increase the upper thread tension. Decrease the lower thread tension.</p>
	<p>面線張力過大或底線張力過小。 Upper thread tension too strong Lower thread tension too weak</p>	<p>減小面線張力。增大底線張力。 Decrease the upper thread tension. Increase the lower thread tension.</p>

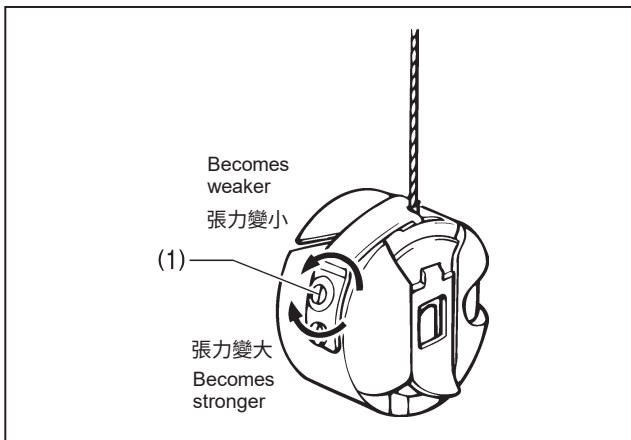

<底線張力>

拉住從梭芯套中露出的線頭，轉動調節螺釘(1)進行調節直至梭芯套以自重慢慢垂落。

<Lower thread tension>

Adjust by turning the adjustment screw (1) until the bobbin case drops gently by its own weight while the thread end coming out of the bobbin case is held.

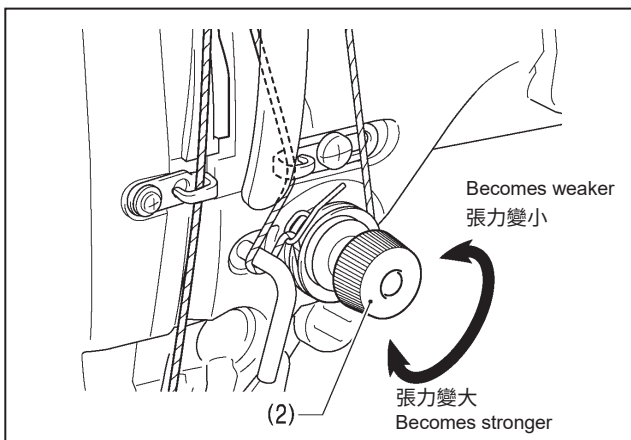

<面線張力>

在底線張力調節之後，調節面線張力以使針腳均勻平整。

1. 降下壓腳。
2. 轉動夾線螺母(2)進行調節。

<Upper thread tension>

After the lower thread tension has been adjusted, adjust the upper thread tension so that a good, even stitch is obtained.

1. Lower the presser foot.
2. Adjust by turning the tension nut (2).

8. 鍍梭供油量的調整



注意



在檢查鍍梭供油量時，手指和油量測試紙不能碰到鍍梭和送布機構等運動零部件。是導致人員受傷的原因。

更

換了鍍梭或要變更縫紉速度時，請按下述步驟調整鍍梭的供油量。

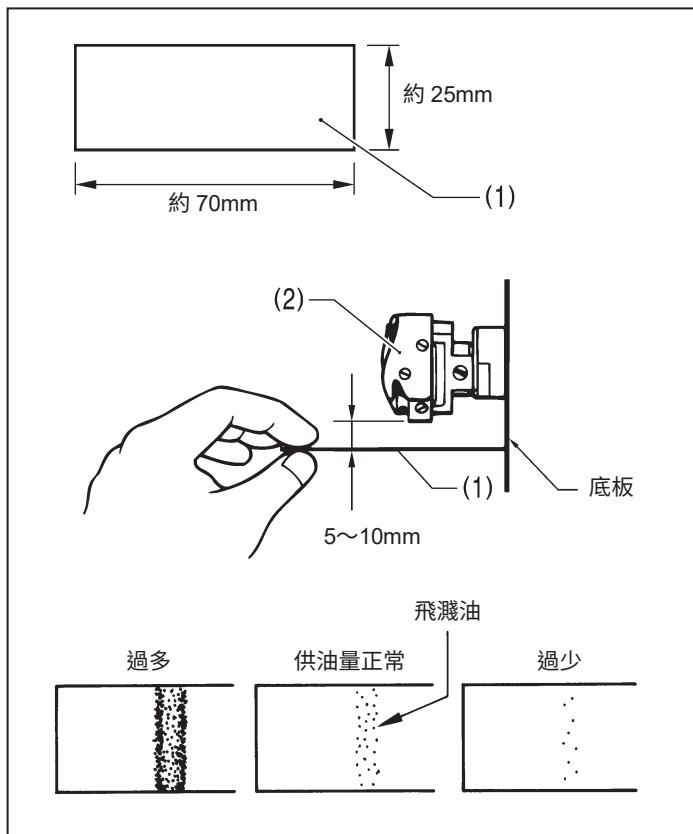

<供油量的確認>

1. 拆去挑線杆至機針上的線。
2. 用抬壓腳扳手抬起壓腳。
3. 以縫紉機實際縫紉時的轉速進行約 10 分鐘的空運轉 (适度的斷續運轉)。
4. 將油量測試紙(1)插入鍍梭(2)的下面并握住，以縫紉機實際進行縫紉時的轉速使縫紉機運轉 10 秒鐘。(對油量測試紙(1)的紙質沒有什麼要求。)
5. 確認飛濺到測試紙上的油量。

當需要進行調整時，請按下面(供油量的調整)一節所述進行調整。

[注意]

如果供油量的檢查結果不符合左圖所示的狀態(飛濺到紙上的油迹呈完整的帶狀或一點也沒有飛濺出來)，則請向右轉動油量調整螺釘(3)將其完全擰入，然後再向左轉動擰出 3 圈半，在松開的狀態下進行下述的調整作業。

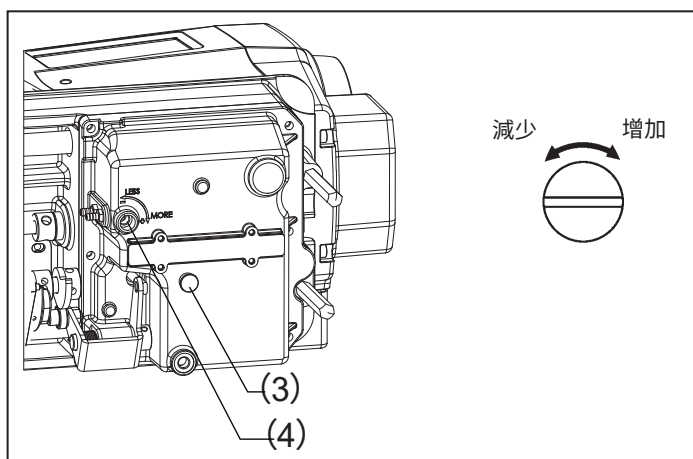

<供油量的調整>

1. 將縫紉機頭部倒下。
2. 取出橡皮塞 (3)。
3. 轉動油量調整螺釘 (4)，調整供油量。
 - 向右轉動油量調整螺釘 (3)，供油量增加
 - 向左轉動油量調整螺釘 (3)，供油量減少。
4. 參照上述 [供油量的確認] 所述來檢查供油量。
 - * 請反復轉動油量調整螺釘，進行調整及供油量的確認，直到獲得適當的供油量為止。
5. 將橡皮塞裝回原處。
6. 在進行了約 2 小時的縫紉后，請再次檢查供油量。

8. Adjusting the rotary hook lubrication amount

⚠ CAUTION



Be careful not to touch your fingers or the lubrication amount check sheet against moving parts such as the rotary hook or the feed mechanism when checking the amount of oil supplied to the rotary hook. If care is not taken, injury may result.

Use the following procedure to check the amount of oil being supplied to the rotary hook when replacing the rotary hook or when changing the sewing speed.

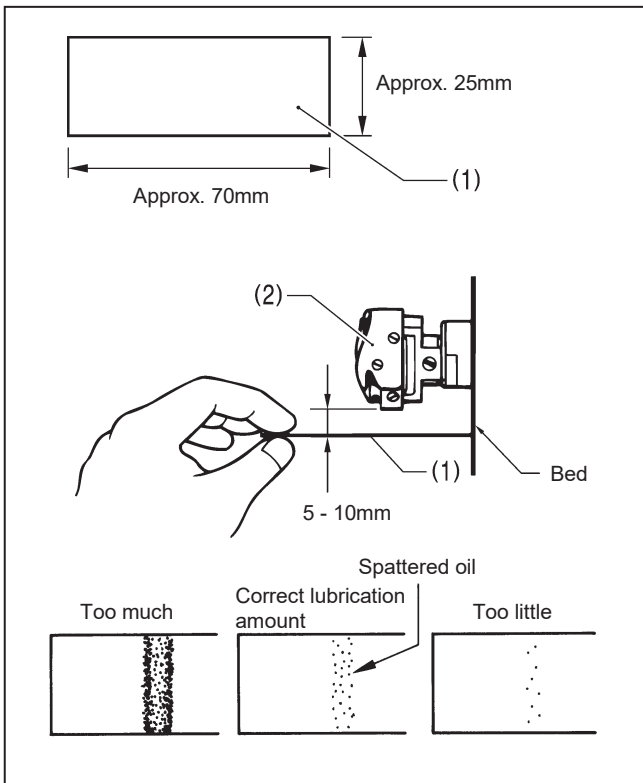

<Checking the lubrication amount>

1. Remove the thread from all points from the thread take-up lever to the needle.
2. Use the lifting lever to lift the presser foot.
3. Run the machine at the normal sewing speed for approximately 10 minutes without sewing any material (following the same start/stop pattern as when actually sewing).
4. Place the lubrication amount check sheet (1) to the left of the rotary hook (2) and hold it there. Then run the sewing machine at the normal sewing speed for 10 seconds. (Any type of paper can be used as the lubrication amount check sheet (1).)
5. Check the amount of oil which has spattered onto the sheet.

If adjustment is necessary, carry out the following operations in "Adjusting the lubrication amount".

NOTE:

If the lubrication amount does not match the correct amount shown in the illustration at left (if the amount of spattered oil is too much or none at all), turn the adjusting screw (3) clockwise to fully tighten it, turn it back counterclockwise by 3 1/2 turns, and then carry out the following adjustment.

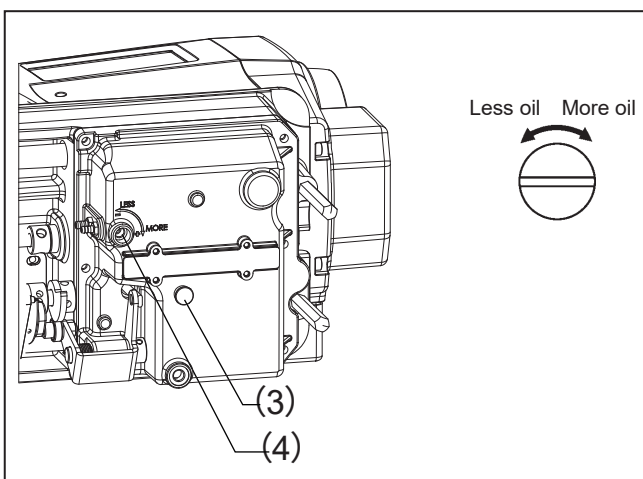

<Adjusting the lubrication amount>

1. Tilt back the machine head.
2. Remove the rubber cap (3).
3. Turn the adjusting screw (4) to adjust the lubrication amount.
 - If the rotary hook adjusting screw (4) is turned clockwise, the lubrication amount becomes greater.
 - If the rotary hook adjusting screw (4) is turned counterclockwise, the lubrication amount becomes smaller.
4. Check the lubrication amount again according to the procedure given in "Checking the lubrication amount" above.
 - * Turn the rotary hook adjusting screw (4) and check the lubrication amount repeatedly until the lubrication amount is correct.
5. Put the rubber (3) stopper back in place .
6. Check the lubrication amount again after the sewing machine has been used for approximately two hours.

9. 切刀的調節

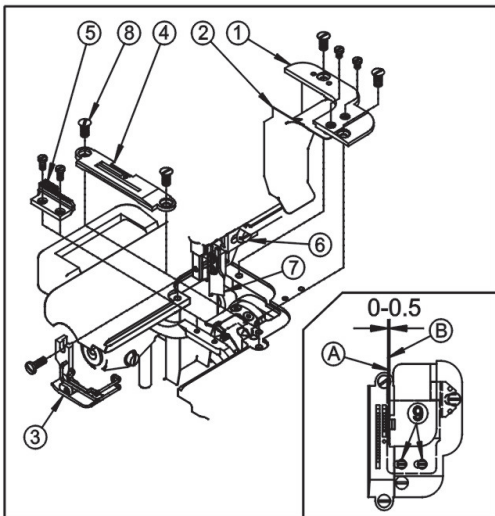
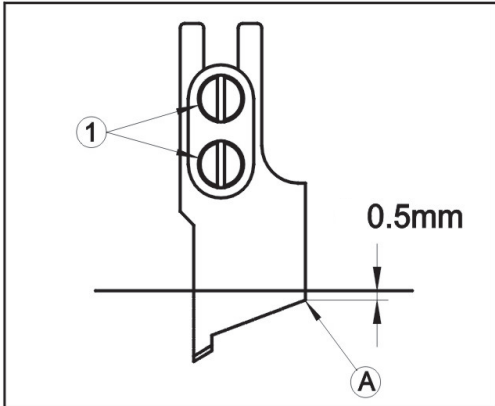
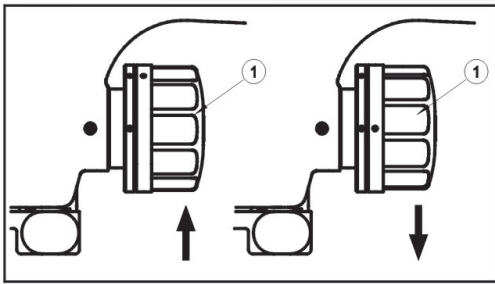

1. 切刀的操作:

- 1) 要使切刀動作時,請把機頭上的切刀開關①向下旋轉;
- 2) 要使切刀停止動作時,請把切刀開關①向上抬起,切刀上升,停止動作;
- 3) 切刀的操作,務必在縫紉機停止運轉之后再進行。

2. 切刀的安裝:

- 1) 如圖所示安裝切刀,切刀下降到最低點時,上下移動切刀,讓切刀的A部比針板面低0.5mm;

- 2) 更換切刀時,請擰松2個切刀固定螺釘①后進行更換。

3. 切斷寬度的更變:

切斷寬度有3.2、4、4.8、6.4四種規格。

- 1) 卸下針板擋板①(帶針板導屑罩②),壓腳③,針板④,送步牙⑤;2) 擰松刀架固定螺釘⑥;

- 3) 安裝上適合切斷寬度的送步牙、針板、壓腳、針板導屑罩;

- 4) 轉動手輪,使切刀⑦降到最低點;

- 5) 將切刀⑦的前端部輕輕地頂到針板A面,然后擰緊切刀支架固定螺釘⑥。(另外,用手指把針板固定螺釘⑧按壓到切刀側,然后擰緊,就可以使切刀鋒利地斷布)

- 6) 擰松針板導屑罩螺釘⑨,針板導屑罩內側B面在針板A面的左側0.5mm位置;

- 7) 擰緊針板導屑罩螺釘⑨。

9. Thread trimming

1. Operation of the cutter:

- 1) To make the cutter move, please turn the cutter switch ① on the machine head downward;
- 2) To stop the cutting knife, please lift the cutting switch ① upwards, the cutting knife will rise, and stop the movement;
- 3) The operation of the cutter must be performed after the sewing machine stops.

2. Installation of cutter:

- 1) Install the cutter as shown in the figure. When the cutter is lowered to the lowest point, move the cutter up and down so that the A part of the cutter is 0.5mm lower than the needle plate surface;

- 2) When replacing the cutter, please loosen the 2 cutter fixing screws ① and then replace it.

3. Change of cutting width:

The cutting width has four specifications of 3.2, 4, 4.8, and 6.4.

- 1) Remove the needle plate baffle ① (with needle plate chip guide cover ②), presser foot ③, needle plate ④, feeder ⑤; 2) Loosen the tool holder fixing screw ⑥;

- 3) Install the stepping teeth, needle plate, presser foot, suitable for cutting width

Needle plate chip guide cover;

- 4) Turn the hand wheel to lower the cutter ⑦ to the lowest point;

- 5) Push the front end of the cutter ⑦ slightly to the surface A of the needle plate, and then tighten the cutter holder fixing screw ⑥. (In addition, press the needle plate fixing screw ⑧ to the side of the cutter with your fingers, and then tighten it, the cutter can cut the cloth sharply)

- 6) Loosen the needle plate chip guide cover screw ⑨, the inner side B of the needle plate chip guide cover is 0.5mm on the left side of the needle plate A side;

- 7) Tighten the needle plate chip guide screw ⑨.

10. 膝控安裝

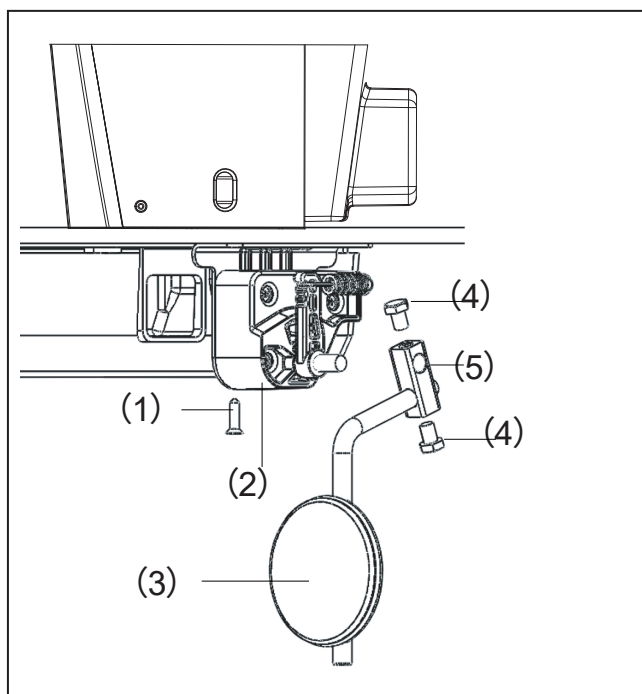

- 1.將電子膝靠組件 (2) 固定在台板上，旋緊固定螺釘 (1)。
- 2.將膝控組件 (3) 與膝控接頭 (5)、電子膝靠組件 (2) 連接。
- 3.擰緊螺釘 (4)
- 4.安裝后檢查膝控組件是否靈活。

10. Knee control installation

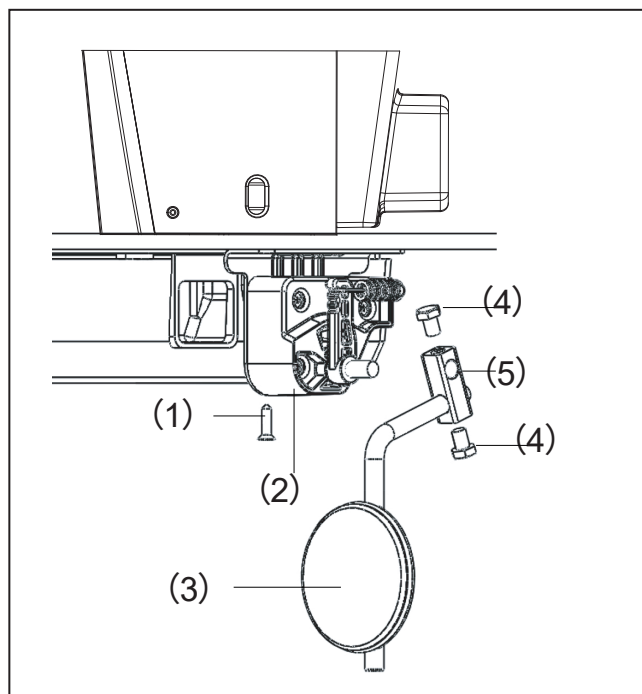

- 1.The electronic knee assembly (2) is fixed on the plate and the fixed screw (1) is tightened.
- 2.Connect the knee control assembly (3) with the knee control joint (5) and the electronic knee assembly (2).
3. Tighten the screw (4) .
4. Check whether the knee control is flexible after installation.

SIRUBA PARTS LIST	Series	Parts Group	Subclass Remark	Page
	DL7500-RNM1	01		1 / 1
				Date
				2022/04/29

1.機體部分/Machine body

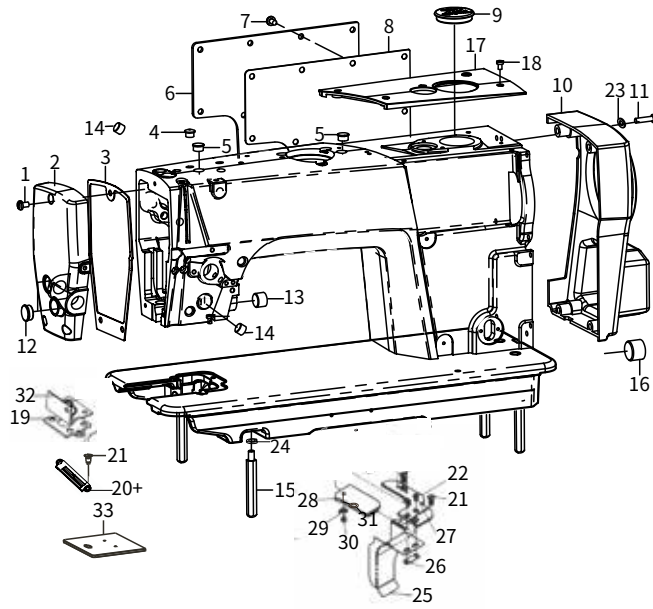

序號	圖號	數量	零件名稱	NAME OF PARTS
1	062711212	3	螺釘 SM4.76×32-12	SCREW SM4.76×32-12
2	167012001	1	面板	PANEL
3	167012101	1	面板墊	PANEL PAD
4	115011401	4	橡皮塞 8.5	RUBBER STOPPER 8.5
5	101011001	2	橡皮塞 12.5	RUBBER STOPPER 12.5
6	115010401	1	后窗板	REAR WINDOW
7	062501216	9	螺釘 M5×12	SCREW M5×12
8	115010501	1	后窗板襯墊	REAR WINDOW PANEL GASKET
9	168010901	1	橡皮塞 37.8	RUBBER STOPPER 37.8
10	168012101	1	馬達罩	MOTOR COVER
11	018502532	4	螺釘 M5×25	SCREW M5×25
12	115010701	3	橡皮塞 15.5	RUBBER STOPPER 15.5
13	152307801	1	孔塞 13.5	HOLE PLUG 13.5
14	152307901	2	孔塞 12.5	HOLE PLUG 12.5
15	168011701	4	底板支柱	FLOOR SUPPORT
16	101011401	1	橡皮塞 20.9	RUBBER STOPPER 20.9
17	168012001	1	頂蓋	TOP COVER
18	168012501	5	螺釘 M3×8	SCREW M3×8
19	152303501	1	針杆密封板	NEEDLE BAR SEALING PLATE
20+	152307201	1	針板1/8	NEEDLE PLATE 1/8
20+	152307202	1	針板3/16	NEEDLE PLATE 3/16
20+	152307203	1	針板1/4	NEEDLE PLATE 1/4
21	115023501	4	螺釘SM4.37-40×6	SCREW SM4.37-40×6
22	152204501	1	針板擋板	NEEDLE PLATE BAFFLE
23	025050132	4	墊圈5	WASHER 5
24	028060246	4	彈簧墊圈T6	SPRING WASHER T6
25	152204801	1	針板導屑罩	NEEDLE PLATE CHIP GUIDE
26	152204901	1	針板導屑罩墊塊	NEEDLE PLATE CHIP GUIDE BLOCK
27	152205001	2	針板導屑罩螺釘	NEEDLE PLATE CHIP GUIDE SCREW
28	152205101	1	針板導屑口蓋板	CHIP GUIDE PORT COVER
29	152205201	1	導屑口蓋板簧	CHIP GUIDE COVER LEAF SPRING
30	152205301	1	導屑口蓋板螺釘	CHIP GUIDE COVER SCREW
31	025040132	1	平墊圈4	FLAT WASHER 4
32	152303601	1	針杆密封板墊	NEEDLE BAR GASKET
33	101011801	1	推板組件	PUSH PLATE ASSEMBLY

SIRUBA PARTS LIST	Series	Parts Group	Subclass Remark	Page
	DL7500-RNM1	02		1 / 1
				Date
				2022/04/29

2.上軸裝置/Shaft mechanism

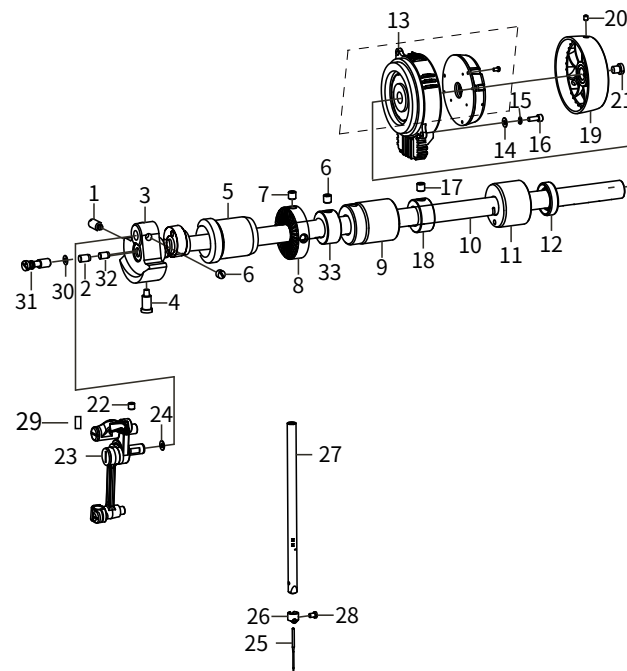

序號	圖號	數量	零件名稱	NAME OF PARTS
1	101031601	1	螺釘 SM7.14	SCREW PAN SM7.14
2	101034301	1	油量銷套	OIL QUANTITY PIN SLEEVE
3	152306401	1	針杆曲柄	COUNTER WEIGHT
4	101031801	1	螺釘 SM7.14	SCREW PAN SM7.14
5	152206101	1	上軸前軸套	MAIN SHAFT BUSHING FRONT
6	014770632	4	螺釘 SM6.35	SCREW SM6.35
7	014050832	2	螺釘 M5×8	SCREW PAN M5×8
8	101032101	1	繞線驅動輪	BOBBIN WINDER DRIVING WHEEL
9	168020901	1	上軸中軸套	BUSHING INTERMSDIATE
10	152206201	1	上軸	MAIN SHAFT
11	168021101	1	上軸后軸套	MAIN SHAFT BUSHING READ
12	115024001	1	油封	OIL SEAL
13	168021302	1	馬達組件	SERVO NOTOR ASSY
14	028050246	3	彈性墊圈	SPRING WASHER
15	025050132	3	墊圈 M5	WASHER M5
16	018501432	3	螺釘 M5×14	SCREW PAN M5×14
17	115024801	2	螺釘 SM6.35×40-6	SCREW SM6.35×40-6
18	101032501	1	上軸擋圈	THRUST COLLAR
19	115025303	1	手輪	HANG WHEEL ASM
20	012501032	2	螺釘 M5×10	SCREW PAN M5×10
21	115025401	1	螺釘 SM8.73	SCREW PAN SM8.73
22	012061032	1	螺釘 M6×10	SCREW PAN M6×10
23	101031401	1	挑線杆組件	THREAD TAKE-UP LEVER ASM
24	115021402	1	墊圈	WASHER
25	115024101	1	機針 DB×1 14	NEEDLE DB×1 #14
26	152206601	1	針杆過線環	NEEDLE BAR THREAD GUIDE
27	152206302	1	針杆	NEEDLE BAR
28	101041001	1	支針螺釘 SM3.18	SCREW PAN SM3.18
29	101030601	1	挑線杆防油套	THREAD TAKE-UP OIL SLEEVE
30	081004870	1	O型圈 6.5x1.5	O-RING 6.5X1.5
31	101034201	1	油量偏心銷	OIL QUANTITY ECCENTRIC PIN
32	101034102	1	上軸油氈	UPPER SHAFT LINOLEUM
33	101032502	1	上軸擋圈	UPPER SHAFT RETAINING RING

1

2

3

4

5

SIRUBA PARTS LIST	Series	Parts Group	Subclass Remark	Page
	DL7500-RNM1	03		1 / 1
				Date
				2022/04/29

3.送料裝置/Feed mechanism components

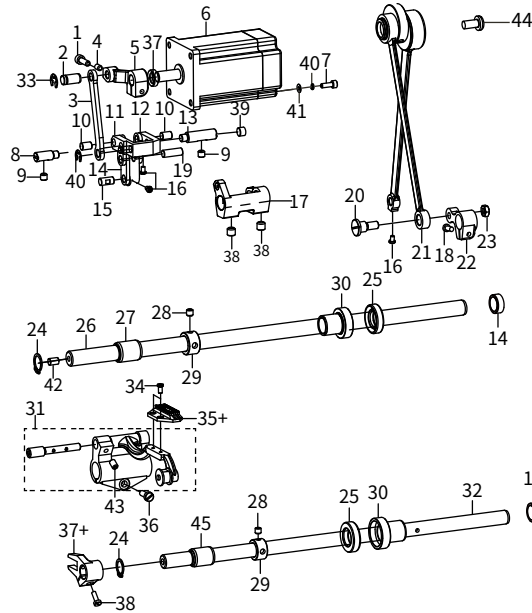

序號	圖號	數量	零件名稱	NAME OF PARTS
1	018501636	1	螺釘 M5×16	SCREW PAN M5×16
2	168040201	1	連杆銷	STUD
3	168040301	1	倒縫連杆	F-REGULATOR CONNECT ROD
4	014680632	1	螺釘 SM4.37-40x6	SCREW PAN SM4.37-40x6
5	168040501	1	倒縫曲柄	INVERTED CAANK
6	168040602	1	倒縫步進電機	BACKSEWING STEPPING MOTOR
7	018401436	4	螺釘 M4×14	SCREW PAN M4×14
8	101061501	1	擺動板座左銷	ADJUSTING LINK FULCRUM SHAFT
9	014760832	2	螺釘 SM5.95	SCREW PAN SM5.95
10	101061801	2	擺動板連接銷	SWING PLATE CONNECTING PIN
11	168041101	1	切換器	LEVEL FEED REGULATOR
12	101064102	1	擺動板套件	SWING PLATE KIT
13	168041301	1	切換器右銷	ADJUSTING LINK FULCRUM SHAFT
14	125013001	2	孔塞15.2	HOLE PLUG 15.2
15	101060901	1	送料連杆銷	WLSKING FOOT PIN
16	101022801	5	螺釘 SM3.57	SCREW PAN SM3.57
17	152303101	1	針送布下曲柄	Needle feeding lower crank
18	101063501	2	螺釘 SM4.76x28	SCREW PAN SM4.76x28
19	101063401	1	送料曲柄銷	NWALKING FOOT PIN
20	101061101	1	軸位螺釘SM7.14x28	AXIS SCREW SM7.14X28
21	101060102	1	連杆組件 H	CONNECTING ROD ASM
22	101063601	1	拾牙后曲柄	READ CRANK ASM
23	101063701	1	螺母 SM5.95	NUT SM5.95
24	048140142	2	擋圈 C14	RING C14
25	125064301	2	油封	OIL SEAL
26	168042601	1	送布軸	FEED ROCKER SHAFT
27	101063101	1	送布軸前軸套	FEED ROCKER SHAFT METAL
28	101063001	4	螺釘 SM6.35	SCREW PAN SM6.35
29	101062901	2	送布軸擋圈	THRUST COLLAR
30	168043001	2	送布軸中套	FEED ROCKER SHAFT METAL
31	101062101	1	牙架組件	TOOTH FRAME COMPONENTS
32	168043901	1	拾牙軸	LIFT THE TOOTH SHAFT
33	048050342	2	卡簧 E5	CIRCLIP E5
34	115047001	2	螺釘 SM3.18	SCREW PAN SM3.18
35+	152307301	1	送料牙 3/16	FEED DOG 3/16
35+	152307302	1	送料牙 1/4	FEED DOG 1/4
36	101062701	1	螺釘 SM5.95	SCREW PAN SM5.95
37	169041101	1	油封	OIL SEAL
38	152303201	2	驅動下曲柄螺釘	Screw SM7.14
39	115011001	1	孔塞10.5	HOLE PLUG 10.5
40	028040246	4	彈簧墊圈T4	SPRING WASHER T4
41	025040132	4	平墊圈4	FLAT WASHER 4
42	115082801	4	油氈	LINOLEUM
43	101062601	1	螺釘SM4.37-40x7	SCREW SM4.37-40X7
44	101060601	2	螺釘SM6.35-40x11	SCREW SM6.35-40X11
45	101063102	1	拾牙軸前軸套	FRONT BUSHING OF LIFTING SHAFT

A

B

C

D

E

4. 鍍梭裝置/Hook components

A
B
C
D
E

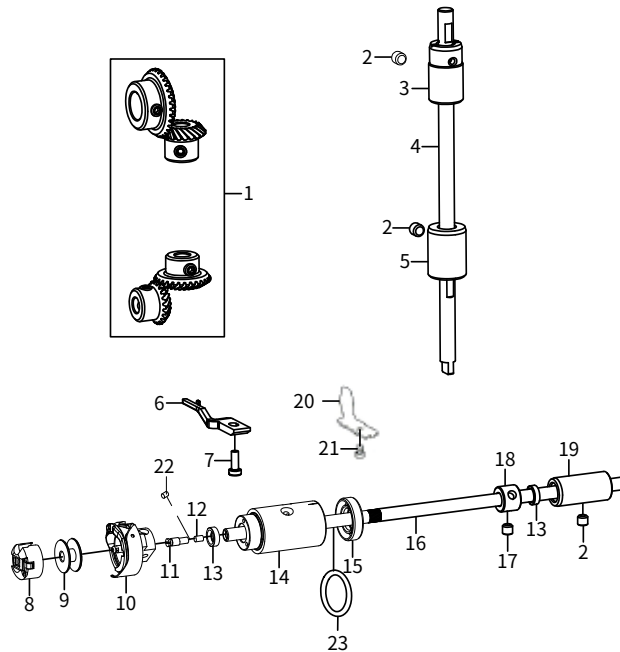

序號	圖號	數量	零件名稱	NAME OF PARTS
1	101041301	1	傘齒輪組件	BEVEL GEAR ASSY
2	014760832	3	螺釘 SM5.95	SCREW SM5.95
3	168050301	1	豎軸上軸套	VERTICAL SHAFT BUSH U
4	101041902	1	豎軸	VERTICAL SHAFT
5	101042201	1	豎軸下軸套	VERTICAL SHAFT BUSH D
6	115072204	1	鍍梭定位勾	HOOK STOPPER
7	115072601	1	螺釘 SM4.37	SCREW PAN SM4.37
8	115072701	1	梭芯套組件	BOBBIN GASE ASSY
9	115072401	1	梭芯	BOBBIN
10	115072313	1	鍍梭組件	ROTARY HOOK ASSY
11	115071401	1	油蓋螺釘	OIL COVER SCREW
12	125043201	1	油芯	OIL CORE
13	115073401	2	油封	OIL SEAL
14	168051401	1	下軸前套	PUMP BUSH
15	115071601	1	油封	OIL SEAL
16	101042901	1	下軸	ROTARY HOOK SHAFT
17	014770532	2	螺釘 SM6.35	SCREW PAN SM6.35
18	115072001	1	緊圈	SET SCREW COLLAR
19	168051901	1	下軸后軸套	BUSHING THREAD FINGER
20	168052001	1	分線片(單刀)	LOWER THREAD FINGER
21	101080701	1	螺釘 SM3.57	SCREW PAN SM3.57
22	115073601	1	小油氈	SMALL LINOLEUM
23	115073301	2	O型圈	O-RING

SIRUBA PARTS LIST	Series	Parts Group	Subclass Remark	Page
	DL7500-RNM1	06		1 / 1
				Date
				2022/04/29

6.穿線裝置/Threading mechanism

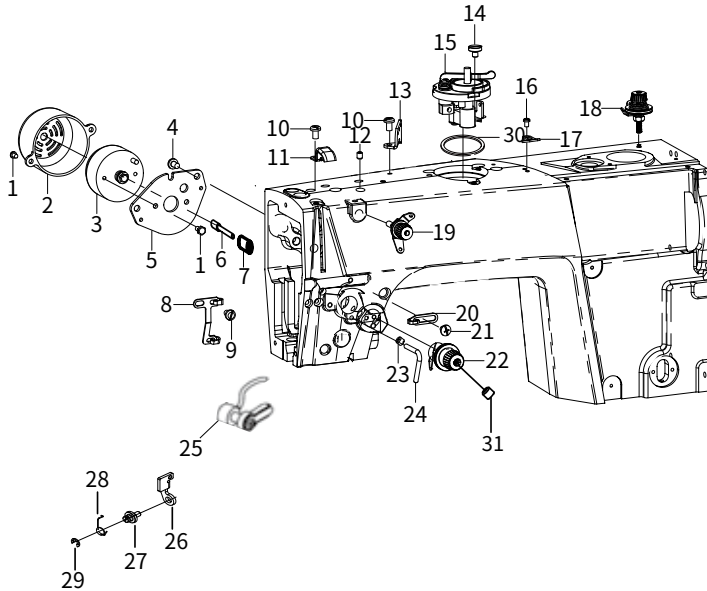

序號	圖號	數量	零件名稱	NAME OF PARTS
1	062400616	4	螺釘 M4×6	NEEDLE CLAMP SCREW PAN M4×6
2	168070201	1	電磁鐵罩	SOLENOID COVER
3	166070301	1	松線電磁鐵組件	ELEC TENSION RELEASE ASSY
4	062500816	2	螺釘 M5×8	SCREW PAN M5×8
5	168070802	1	電磁鐵安裝板	SOLENOID SETTING PLATE
6	152360601	1	松線銷	TENSION SHAFT
7	167123101	1	松線杆襯套	SLEEVE FOR LOOSE WIRE ROD
8	115091201	1	面線線勾	FACE PLATE THREAD GUIDE
9	125022201	1	螺釘 M4×6	SCREW PAN M4×6
10	101010901	2	螺釘 SM4.76	SCREW PAN SM4.76
11	101010801	1	挑線杆防護罩	THREAD TAKE-UP LEVER COVER
12	101022201	1	螺釘 SM4.76	SCREW PAN SM4.76
13	115090301	1	穿線板	SPOOL PLATE
14	101022601	3	螺釘 M5×10	SCREW PAN M5×10
15	101022501	1	繞線器組件	BOBBIN WINDER ASM
16	101022801	2	螺釘 SM3.57	SCREW PAN SM3.57
17	101022701	1	割線刀	KNIFE
18	168072301	1	繞線器夾線組件	BOBBIN THREAD TENSION ASM
19	168072201	1	調線夾線器組件	THREAD TENSION ASM
20	101020701	1	右線勾	RIGHT LINE HOOK
21	101020201	1	螺釘 SM4.37-40x6	SCREW PAN SM4.37-40x6
22	168072501	1	夾線器組件 M	THREAD TENSION ASSY M
23	115111601	1	螺母 SM4.37	NUT SM4.37
24	101020502	1	大線勾	BIG WIRE HOOK
25	152307601	1	電子夾線器	ELECTRONIC WIRE CLAMING DEVICE
26	167035101	1	松線傳動杆	LOOSE WIRE TRANSMISSION LEVER
27	167305201	1	軸位螺釘SM4.76	AXIS SCREW SM4.76
28	167031701	1	彈簧	SPRING
29	048040342	1	卡簧E4	CLAMP SPRING E4
30	168072901	1	繞線器密封墊	WASHER
31	101020401	1	螺釘SM5.95-28X7	SCREW SM5.95-28X7

1

2

3

4

5

SIRUBA PARTS LIST	Series	Parts Group	Subclass Remark	Page
	DL7500-RNM1	07		1 / 1
				Date
				2022/04/29

7.壓腳裝置/Presser foot mechanism

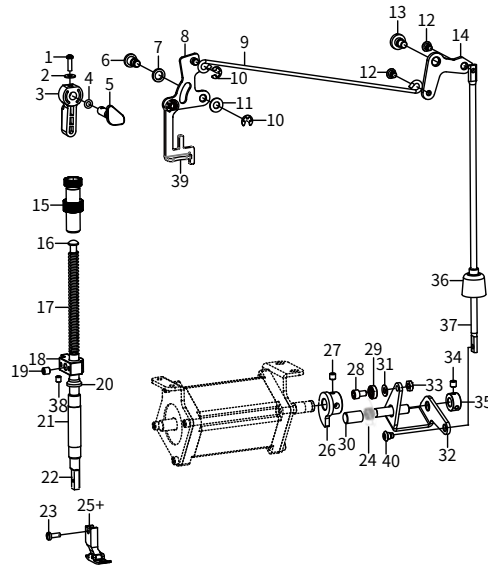

序號	圖號	數量	零件名稱	NAME OF PARTS
1	101054501	1	螺釘 SM3.57	SCREW SM3.57
2	101054601	1	墊圈 3.7	WASHER 3.7
3	168030301	1	抬壓腳扳手	HAND LIFTER
4	081004070	1	O型圈 P4	RING P4
5	102050601	1	抬壓腳凸輪	PRESS FOOT LIFTER CAM ASM
6	101052001	2	前杠杆螺紋銷	LINK SHAFT
7	101052101	2	防油橡膠墊(薄)	WASHER
8	168031001-1	1	抬壓腳前杠杆	HANK LIFTER LINK
9	167034401	1	抬壓腳拉杆	LIFTING LEVER LINK
10	048050342	3	卡簧 E5	SNAP RING E5
11	101056301	1	墊圈 6.35	WASHER 6.35
12	115034301	2	軸位螺釘 SM4.76	SCREW SM4.76
13	115034501	1	軸位螺釘 SM6.35	SCREW SM6.35
14	167052401	1	抬壓腳后杠杆	LEVER AFTER LIFTING THE PRESSER FOOT
15	168031501	1	調壓螺釘組件	PRESSURE REGULATING BOL
16	101050301	1	調壓導杆	PRESSER GUIDE BAR
17	125050401	1	調壓簧	PRESSER SPRING
18	152305401	1	壓杆導架	NEEDLE BAR GUIDE BAACKET
19	014770632	1	螺釘 SM6.35	SCREW SM6.35
20	101050901	1	壓杆套防油圈	SHOCK PAD
21	152305501	1	壓杆襯套	PRESSER BAR BUSHING LOWER
22	152205501	1	壓杆	PRESSER BAR
23	115031001	1	螺釘 SM3.57	SCREW SM3.57
24	168033801-1	1	壓腳复位簧	PRESSER FOOT RESET SPRING
25+	152307102	1	壓腳 3/16	MPRESSER FOOT 3/16
26	168032701	1	抬壓腳凸輪	HAND LIFTER CAM
27	014600832	2	螺釘 M6×8	SCREW PAN M6×8
28	018601232	1	螺釘 M6×12	SCREW PAN M6×12
29	169034001	1	軸承	BEARING
30	168033101	1	抬壓腳曲柄軸	PRESSER FOOT CRANK SHAFT
31	025060236	1	平墊圈 6	FLAT WASHER 6
32	168033201	1	抬壓腳驅動曲柄	OT DRIVING CRANK
33	021600306	1	螺母 M6×0.75	NUT M6×0.75
34	012500632	2	螺釘 M5×6	SCREW PAN M5×6
35	168033501	1	曲柄軸擋圈	SET SCREW COLLAR
36	168033601	1	膝控提升杆橡皮塞	RUBBER CAP
37	168033701	1	抬壓腳頂杆	CONNECTING ROD VERTICAL
38	115034201	1	抬壓腳減震墊	CUSHION
39	152304201	1	壓腳升降板	PRESSER FOOT LIFTING PLATE
39	168031301	1	軸位螺釘 SM4.76x32	AXIS SCREW SM4.76X32

A

B

C

D

E

1

2

3

4

5

SIRUBA PARTS LIST	Series	Parts Group	Subclass Remark	Page
	DL7500-RNM1	08		1 / 1
				Date
				2022/04/29

8. 針送布部件/Rock shaft assembly

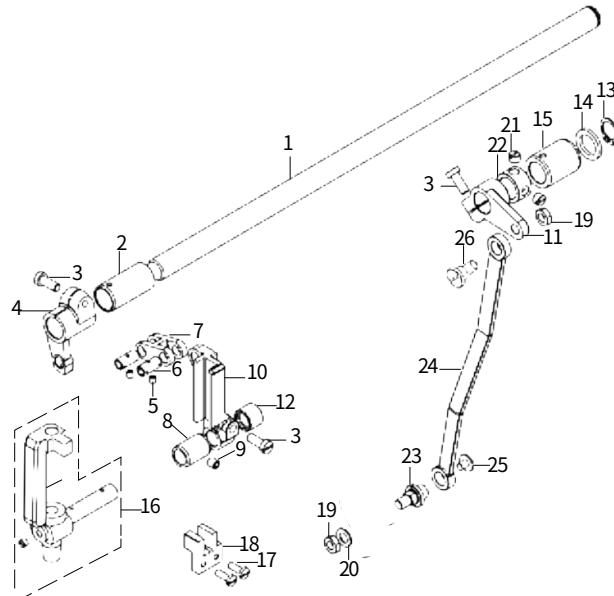

序號	圖號	數量	零件名稱	NAME OF PARTS
1	152300101	1	針送布襪動軸	NEEDLE FEEDING SWING SHAFT
2	152300401	1	針送布襪動前軸套	NEEDLE FEEDING SWING FRONT BUSHING
3	152300301	3	螺釘SM4.76-28X12	SCREW SM4.76-28×12
4	152300201	1	針杆襪動曲柄	NEEDLE BAR SWING CRANK
5	152300701	2	螺釘SM3.57-40×4	SCREW SM3.57-40×4
6	152300501	2	針杆襪動連杆銷	NEEDLE BAR SWING LINK PIN
7	152300601	1	針杆襪動連杆	NEEDLE BAR SWING LINK
8	152302201	2	針杆襪動架軸套	NEEDLE BAR SWING FRAME BUSHING
9	012501032	1	螺釘M5×10	SCREW M5×10
10	152301901	1	針杆導向滑動曲柄組件	NEEDLE BAR GUIDE SLIDING CRANK ASM
11	152302801	1	針送布驅動上曲柄	NEEDLE FEED DRIVE UPPER CRANK
12	167301801	1	外圈滾針軸承BK0910	OUTER RING NEEDLE ROLLER BEARINGS BK0910
13	048120142	1	軸用彈性擋圈12	CIRCLIP FOR SHAFT 12
14	152301101	1	墊圈12.7	WASHER 12.7
15	152301001	1	針送布襪動后軸套	SHAFT SLEEVE AFTER NEEDLE FEEDING SWING
16	152302501	1	針杆襪動架組件	NEEDLE BAR SWING FRAME ASSEMBLY
17	115031001	2	螺釘SM3.57-40X10	SCREW SM3.57-40X10
18	152302401	1	襪動架導軌	SWING RACK RAIL
19	152203201	2	螺母SM5.95X28	NUT SM5.95X28
20	152203101	1	墊圈6.35	WASHER 6.35
21	152300901	2	螺釘1/4-40×4.5	SCREW 1/4-40×4.5
22	152300801	1	擋圈12.7	RETAINING RING 12.7
23	152301501	1	針送布驅動連杆接頭	NEEDLE FEED DRIVE LINK CONNECTOR
24	152301301	1	針送布驅動連杆	NEEDLE FEED DRIVE LINK
25	152302701	1	螺釘SM4.37-40×5	SCREW SM4.37-40×5
26	152301201	1	驅動連杆軸位螺釘	DRIVE CONNECTING ROD SHAFT SCREW
27	152302801	1	針送布驅動雙曲柄	NEEDLE FEED DRIVE DOUBLE CRANK

1

2

3

4

5

SIRUBA PARTS LIST	Series	Parts Group	Subclass Remark	Page
	DL7500-RNM1	09		1 / 1
				Date
				2022/04/29

9.切線裝置/Thread trimmer mechanism

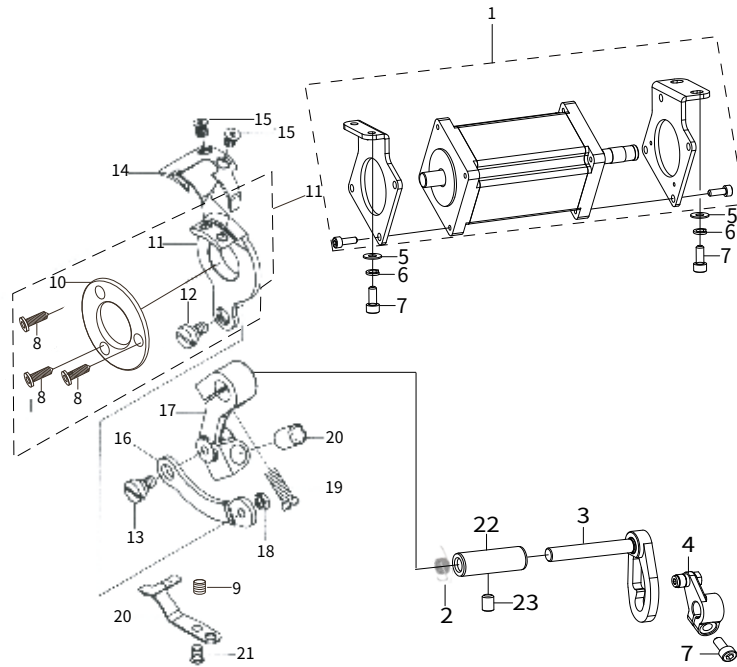

序號	圖號	數量	零件名稱	NAME OF PARTS
1	168080202	1	剪線電機組件	THREAD TRIMMING MOTOR ASSEMBLY
2	125082301	1	動刀复位簧	MOVING KNIFE RESET SPRING
3	166081801	1	切線曲柄	TANGENT CRANK
4	169110101	1	切線驅動曲柄	TANGENT DRIVE CRANK
5	025050132	4	墊圈 5	WASHER 5
6	028050246	4	彈簧墊圈	SPRING WASHER
7	018501432	5	螺釘 M5×14	SCREW M5×14
8	125080401	3	螺釘 M3×5	SCREW M3×5
9	115116001	1	定刀調節螺釘	FIXED KNIFE ADJUSTING SCREW
10	125082501	1	刀架壓板	TOOL HOLDER PRESSURE PLATE
11	168081701	1	刀架	TOOL HOLDER
12	125080601	1	軸位螺釘M4x6	AXIAL SCREW M4X6
13	115111501	1	螺釘SM4.37	SCREW SM4.37
14	101081401	1	活動刀	MOVABLE KNIFE
15	115111301	2	螺釘SM4.37	SCREW SM4.37
16	168081601	1	刀架連杆	TOOL HOLDER CONNECTING ROD
17	179111701	1	切線手杆	TANGENT LEVER
18	021400306	1	螺母M4	NUT M4
19	101081901	1	螺釘SM4.76-32×14	SCREW SM4.76-32×14
20	115110301	1	固定刀	FIXED KNIFE
21	115110401	1	螺釘SM3.57	SCREW SM3.57
22	152082201	1	切線軸套	TANGENT BUSH
23	104760832	1	螺釘SM5.95	SCREW SM5.95

SIRUBA PARTS LIST	Series	Parts Group	Subclass Remark	Page
	DL7500-RNM1	10		1 / 1
				Date
				2022/04/29

10. 切刀部件/Knife assembly

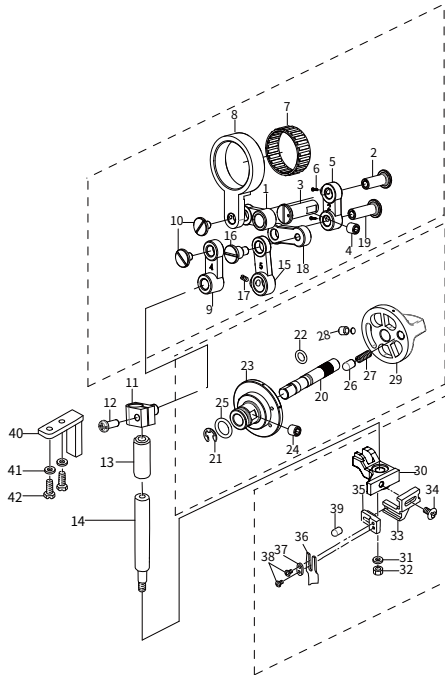

序號	圖號	數量	零件名稱	NAME OF PARTS
1	152200101	1	切刀驅動連桿(1)	CUTTER DRIVE CONNECTING ROD (1)
2	152200201	1	切刀連桿連接銷	CONNECTING PIN
3	152200301	1	驅動連桿定位銷	POSITIONING PIN
4	014600832	1	螺釘M6X8	SCREW M6X8
5	152200501	1	切刀小連桿(2)	CUTTER SMALL CONNECTING ROD (2)
6	101022801	2	螺釘SM3.57-40X5	SCREW SM3.57-40X5
7	152200701	1	切刀大連接桿滾針軸承	NEEDLE ROLLER BEARING
8	152200801	1	切刀大連桿	CUTTER DALIAN ROD
9	152200901	1	切刀杆連桿(4)	CUTTER BAR CONNECTING ROD (4)
10	152201001	2	連接銷螺釘	CONNECTING PIN SCREW
11	152306701	1	切刀杆連接柱	CUTTER BAR CONNECTING COLUMN
12	152201201	1	連接柱螺釘SM3.57-40X9.5	SCREW SM3.57-40X9.5
13	152201301	1	切刀杆襯套	CUTTER BAR BUSH
14	152201402	1	切刀杆	CUTTER BAR
15	152201501	1	切刀開關曲柄(5)	CUTTER SWITCH CRANK (5)
16	152201601	1	切刀開關曲柄軸位螺釘	SCREW FOR CUTTER SWITCH
17	152201701	1	切刀開關軸螺釘SM4.37-40×6	SCREW SM4.37-40×6
18	152201801	1	切刀開關曲柄連桿(3)	CONNECTING ROD (3)
19	152201901	1	切刀杆連桿連接銷	CONNECTING ROD CONNECTING PIN
20	152202001	1	切刀開關軸	CUTTER SWITCH SHAFT
21	048060342	1	擋圈E6	RETAINING RING E6
22	101054101	1	O形圈8.9x1.9	O-RING 8.9X1.9
23	152306801	1	切刀開關座	CUTTER SWITCH SEAT
24	012501032	1	螺釘M5X10	SCREW M5X10
25	152202501	1	O型圈16.6x2.4	O-RING 16.6X2.4
26	152202601	1	切刀開關定位銷	CUTTER SWITCH POSITIONING PIN
27	152202701	1	定位銷彈簧	POSITIONING PIN SPRING
28	014760832	1	螺釘SM5.95-28×8	SCREW SM5.95-28×8
29	152202901	1	切刀鑰鈕	CUTTER KNOB
30	152203001	1	切刀座	CUTTER BLOCK
31	152203101	1	墊圈6.5	WASHER 6.5
32	152203201	1	螺母SM5.95x28	NUT SM5.95X28
33	152203301	1	切刀調節架	CUTTER ADJUSTMENT FRAME
34	152203401	1	切刀調節架螺釘SM4.37-40×8	SCREW SM4.37-40×8
35	152203501	1	切刀架	CUTTER HOLDER
36	152203601	1	切刀	CUTTER
37	152203701	1	切刀墊片	CUTTER GASKET
38	115047001	2	螺釘SM3.18-44X6	SCREW SM3.18-44X6
39	152203901	1	螺釘SM3.57-40x7.5	SCREW SM3.57-40X7.5
40	152204101	1	切刀座導架	CUTTER BASE GUIDE
41	152204201	2	切刀座導架圈	CUTTER HOLDER GUIDE RING
42	152204301	2	切刀座導架螺釘3/16-28×10	SCREW 3/16-28×10

A

B

C

D

E

1

2

3

4

5

SIRUBA PARTS LIST	Series	Parts Group	Subclass Remark	Page
	DL7500-RNM1	11-12		1 / 1
				Date
				2022/04/29

11.倒縫開關裝置/Quick reverse switch mechanism

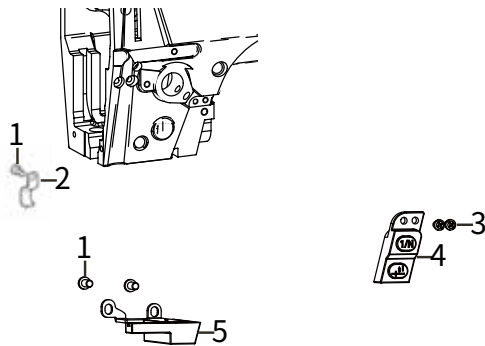

12.控制部分/Control components

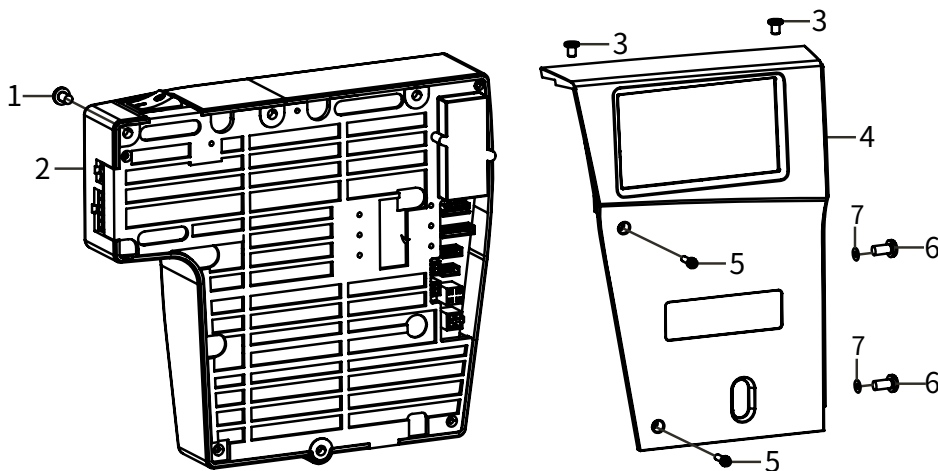

序號	圖號	數量	零件名稱	NAME OF PARTS
1	062500616	4	螺釘 M5×6	SCREW PAN M5×6
2	115140301	2	電線夾 U2	CORD HOLDER U2
3	062400616	2	螺釘M4x6	SCREW PAN M4x6
4	149090101	1	補針開關組件	NEEDLE COMPENSATE SWITCH
5	149090411	1	倒縫開關組件	R-SWICH ASSY
序號	圖號	數量	零件名稱	NAME OF PARTS
1	018501432	3	螺釘 M5×14	SCREW PAN M5×14
2	168101501	1	控制箱組件	CONTROL BOX ASSY
3	101020201	2	螺釘 SM4.37×40-6	SCREW PAN SM4.37×40-6
4	168100601	1	操作盒組件4.3	OPERATION PANEL
5	168012501	2	螺釘 M3×8	SCREW PAN M3×8
6	062500816	2	螺釘 M5×8	SCREW PAN M5×8
7	025050132	2	平墊圈5	WASHER 5

1

2

3

4

5

SIRUBA PARTS LIST	Series	Parts Group	Subclass Remark	Page
	DL7500-RNM1	13		1 / 1
				Date
				2022/04/29

13.附件/Accessories

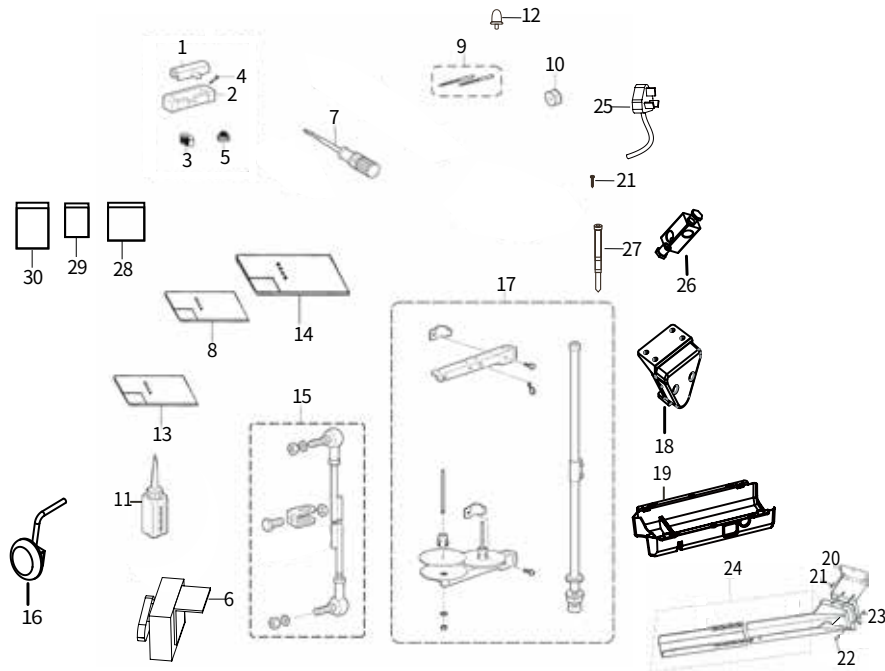

序號	圖號	數量	零件名稱	NAME OF PARTS
1	115150401	2	機頭鉸鏈	NOSE HINGE
2	101120501	2	機頭鉸鏈套	HEAD HINGE COVER
3	125120601	2	頭部防震墊	HEAD SHOCK PAD
4	5050111	4	釘	NAIL
5	125120801	2	頭部防震墊	HEAD SHOCK PAD
6	115152001	1	調速器	GOVERNOR
7	115151701	1	螺絲刀(中)	SCREWDRIVER (MEDIUM)
8	6050169	1	電控說明書	ELECTRIC CONTROL MANUAL
9	115024112	10	機針DB×1 14	NEEDLE DB×1 14
10	115072401	3	梭芯	BOBBIN
11	115151001	1	中號油壺	MEDIUM OIL CAN
12	168111401	1	機頭撐杆	HEAD SUPPORT
13	6050404	1	使用說明書	USER'S GUIDE
14	6050274	1	零件手冊	PARTS MANUAL
15	115151901	1	連杆組件	CONNECTING ROD ASSEMBLY
16	125104001	1	膝控組件	KNEE CONTROL COMPONENTS
17	115151401	1	線架組件 2DR	WIRE RACK ASSEMBLY 2DR
18	169050101	1	電子膝靠組件	ELECTRONIC KNEE REST
19	152308701	1	油盤	OIL PAN
20	152208001	1	導屑滑板支架	CHIP GUIDE SLIDE BRACKET
21	152208101	15	木螺釘ST4.2X25	WOOD SCREW ST4.2X25
22	062401216	3	螺釘M4X12	SCREW M4X12
23	021400306	3	螺母M4	NUT M4
24	152208201	1	漏料槽組件	LEAKAGE CHUTE ASSEMBLY
25	125122801	1	電源線	POWER CABLE
26	125104101	1	膝控接頭	KNEE JOINT
27	5040104	3	扎帶	TIE
28	115160801	1	自封袋	ZIPLOCK BAG
29	115160601	1	自封袋	ZIPLOCK BAG
30	115160701	1	自封袋	ZIPLOCK BAG

1

2

3

4

5



高林股份有限公司
KAULIN MFG. CO., LTD.

由於對產品的改良及更新，本產品使用說明書中與零件圖之產品及外觀的修改恕不事先通知！
The specification and/or appearances of the equipment described in this instruction book & parts list are subject to change because of modification which will without previous notice.
DML-13P11.MAY.2022