

SIRUBA

使用説明書

INSTRUCTIONS BOOK

■ FA007D



安全手冊

SAFETY OPERATION

1、安全標誌及其定義	Safety symbols and definitions	1
2、警告牌及指示標識	Warning label and show tag	1
3、安全措施的基本概念	Basic concept for safety measures	2
(1) 應用和目的	Application and purpose	2
(2) 工作環境	Working environment	2
4、安全操作及其注意	Safety operation and advert	3
(1) 拆箱和運輸	Unpacking and transportation	3
(2) 安裝及準備	Installation and preparation	3
(3) 操作注意事項	Operation advert item	3
(4) 保養與檢修	Maintenance inspection and repair	4

使用說明書

INSTRUCTION MANUEL

1、警告牌及指示標識	Warning label and show tag	5
(1) 警告標識	Warning symbol	5
(2) 轉向標識	Direction of operation	5
(3) 地線標識	Earth wire symbol	5
(4) 安全裝置	Safety devices	5
2、零部件名	Names of major parts	6
3、機器規格	Machine Specification	6
4、台板與電機	Work table and motor	7
(1) 台板	Work table	7
(2) 電機與皮帶	Motor and V-belt	8
5、安裝	Installation	9
(1) 機器安裝簡述	Installation of sewing machine	9
(2) 安裝機頭	Installing the machine head	11

(3) 地線連接	Ground wire connections	12
(4) 安裝皮帶輪及護罩	Installing the pulley cover	12
(5) 皮帶鬆緊的調節	Belt tension adjustment	13
(6) 線架的安裝	Cotton stand	14
(7) 安裝皮帶輪罩殼	Lubrication	14
(8) 檢測皮帶輪轉動的方向	Checking the machine pulley rotating direction	15
6、縫紉前的準備	Correct Operatio	16
(1) 針和線	Needles and Threads	16
(2) 針的安裝	Installing the Needles	16
(3) 穿引下線	Threading the lower threads	17
(4) 穿引上線	Threading the upper threads	17
7、縫紉	Sewing	18
8、縫製的調節	Thread Tension	19
(1) 調節線的鬆緊	Adjusting the thread tension	19
(2) 壓腳壓力調節	Presser Foot Pressure Adjustment	19
(3) 調節縫跡的長度	Stitch Length Adjustment	20
9、清洗處理	Cleaning	22
(1) 日常清洗	Daily cleaning	22
(2) 潤滑	Changing the lubrication oil	22
10、調節標準	Standard adjustments	23
(1) 調節針桿	Needles bar height adjustment	24
(2) 調節針和挑線叉	Needle and looper timing adjustment	25
(3) 調節挑線叉和機針的間隙	Timing of loopers running clear of needles	26
(4) 調節擋針塊	Needle guard adjustment	27
(5) 送料齒高度的調整	Feed dog height adjustment	28
(6) 調整鬆線桿	Thread release lever adjustment	28
(7) 調整上打線器	Upper thread take-up thread guide adjustment	29

(8) 調整上線夾	Upper thread nipper adjustment	29
(9) 鬆線軸的調整	Thread release shaft adjustment	30
(10) 下打線器調整	Lower thread take-up timing adjustment	30
(11) 安裝捲邊器	Installing the lapper	30
(12) 拖輪高度的調節 (配拖輪的機器)	Puller height adjustment(Machines with puller)	31
(13) 拖輪同步的調節 (配拖輪的機器)	Puller timing adjustment(Machines with puller)	31

1、安全標誌及其定義

Safety symbols and definition



- (1)、警告、注意標誌：操作機器時，注意周邊各相關部件或裝置，以避免由此部件或裝置引起的損傷。

Warning. caution symbol: When you are operating the machine, please pay attention to the related parts or devices, to avoid get hurt by these parts or devices.



- (2)、警告、小心標誌：機器操作時，注意運動部件或裝置，避免手或其他人身部位受到損傷。

Warning. be careful symbol When the machine is running please pay attention to the moving parts or devices to avoid the hands or body get hurt.



- (3)、接地線標誌：機器操作時，確保與地線相連接。

Earth wire symbol: When the machine is running please make sure the machine is connecting well with the earth wire.

2、警告牌及指示標識

Warning label and show tag



- (1)、護手裝置：機器操作時，注意運動部件或裝置，避免手或其他人身部位受到損傷。

Finger guide: When the machine is running please pay attention to the running parts or devices to avoid the hands or body get hurt.



- (2)、地線標識：確保地線接地良好，以避免由於環境或其它因素產生的靜電影響人身安全。

Earth wire symbol Make sure the earth wire is connecting well, to avoid affect people's safety by environment or static from other factors.



- (3)、轉向標識：機器操作運轉時確保機器正確的轉向，以避免由此引起的機器損壞。

Turning symbol: When the machine is running please make sure the machine's numming direction is correct, to avoid the machine get damage by this problem.

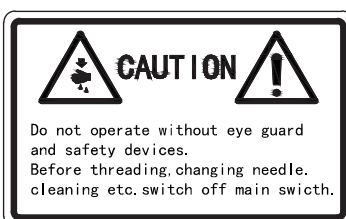

- (6)、警告標識：機器操作運轉時，確保各（如：擋針板、皮帶護罩、接地線等）防護部件按裝到位，以保證人身安全。

Warning symbol When the machine is running, please make sure (eg needle guard, belt cover, earth wire ect) the parts are in the correct places to assure people's safety.

3、安全措施的基本概念

Basic concept for safety measures

1)、應用和目的

Application and purpose

本公司所開發的縫紉機是為提高縫製行業的生產效率，提升產品品質，不推薦您使用與上述使用目的不相符合的縫紉機

The industrial sewing machine developed by our company is for improving production's efficiency in sewing business, we don't recommend you to use the sewing machine which is not the same purpose for you sewing

2)、工作環境

Working environment

(1) 不適合在溫度與濕度較極端的工作環境

The machine is not suitable for working in the extremely temperature and humidity environment.

(2) 不適合在戶外，或光線照射較強的地方

The machine is not suitable for working in outdoor, or the place where is strong sunlight.

(3) 不適合在帶有灰塵，腐蝕性、放射性物質的環境中

The machine is not suitable for working in the environment where is full of dust, or have causticity or radioactivity matter

(4) 不適合在電壓起伏超過上下 10% 幅度

The machine is not suitable for working if the fluctuation of the voltage is exceed 10%

(5) 不符合馬達規格標準的電壓供電

The machine is not suitable for working if the voltage not in accordance with the motor's standard.

(6) 不適合在高電流轉換器，高頻率焊機產生強電流、強磁聲的區域內

The machine is not suitable for working in the areas where is high electric current transducer or strong electric current strong magnetic-acoustic from high frequency soldering machine.

4、安全操作及其注意 Safety operation and advert

1)、拆箱和運輸

Unpacking and transportation

(1) 放置或轉運時確認機器與向上標記擺放一致，拆箱時從箱子頂部打開。

When the machine is putting or transporting please make sure it is the same direction with the up sign, and unpacking the machine at the top of the carton.

(2) 從箱子裡取出機器時，不要用手握住靠針的部位

When you are taking out the machine from the carton please don't catch the place which is near of the needle by your hands.

(3) 有車輛搬運時，切勿使機器遭受強烈震動或撞擊

Please don't let the machines get strong shock or hit when the machines are transporting.

2)、安裝及準備

Installation and preparation

(1) 確保台板安裝堅固，避免台板在承重時由於安裝不到位引起的狀況

Make sure the table is installed firmly, to avoid the talbe can't bear the weight because of the installation's mistake.

(2) 安裝擺放機器時，選擇適當的光線與合理的擺設以保證舒適的工作環境

Choose the proper sunlight place or reasonable place to installation the machine so make sure the environment comfortable.

(3) 根據電機的使用說明來正確安裝電機

According the motor's instruction to install the motor.

(4) 在未完成安裝前，切勿觸按電源

If the installation is not completely finished please don't connect the electric power

(5) 謹慎安裝電線，連接好機器、電機和帶電裝置。

Install the wires carefully, and connect the machine motor, and electrification devices well.

(5) 不要在帶電線路上放置、施加任何物體

Don't put anything on the electrification wires.

(7) 電線需遠離驅動器，

The wires should be far away from the drive.

(8) 連接好接地線

Connecting the earth wire well.

(9) 對操作的員工需進行安全與技能方面的培訓，以保證機器的正確使用與安全的操作。

The operators should be get a safety and skilled training, to make sure the correct and safety operation.

3)、操作注意事項

Operation advert item

(1) 切不可使潤滑油、矽油等濺到眼睛

The lubricant oil and silicon oil can not be spattered in the eyes.

(2) 在添加潤滑油時，應使用本機專用的潤滑油。

Use the special lubricant oil when you are lubrication.

(3) 在接通電源時，切不可把手放到機器的運動部件上

You can not put your hands in the moving parts when you want to turn on the electric power.

(4) 操作前確保機器轉向與機器轉向標誌一致

Make sure the machine's turning direction is the same with the turning direction sign before you operate.

(5) 如果機器配備了皮帶護罩、擋針板等防護裝置時，確保這些安全設備都已裝配

If the machine have belt cover, needle guard. ect please make sure they are all installed.

(6) 使用機器時，手指、頭髮等切勿靠近機針或其它運動部件。

Don't let your fingers, hair ect near of the needle or moving parts when you are operating the machine

(7) 穿線、換機針時，首先需關閉電源

Turn off the electric power before you threading or changing the needle.

(8) 不使用機器時，一定要記得關閉電源

Turn off the electric power when you don't need use the machine.

(9) 使用時，如遇到任何故障或有異常聲響與氣味，要立即切斷電源

When you are operating the machine if the machine get any problems or unusual noise or strange smell, please turn off the electric power immediately.

4)、保養與檢修

Maintenance inspection and repair

(1) 保證機器的維護與維修由專門的技術人員來完成

Machine's maintenance inspection and repair should be finished by special technicians

(2) 對機器的維護與維修必需在切斷電源的狀態下進行。

Turn off the electric power before to maintenance inspection and repair

(3) 如果使用離合器馬達，注意需將馬達餘電使用完後進行

If use clutch motor, please make sure the motor's electricity is out.

(4) 維修過程中請使用指定本機專用零部件。

Use the special parts in your maintenance inspection and repair.

使用說明書 INSTRUCTION MANUAL

1、警告牌及指示標識 Warning label and show tag

使用機器時請遵循標識操作，若標識脫落或是難以識別，請及時與附近的經銷商聯繫。
Please follow the instruction on the labels at all times when using the machine if the labels have been removed or are difficult to read please contact your nearest SIRUBA dealer.

1)、警告標識 Warning symbol



2)、轉向標識 Direction of operation

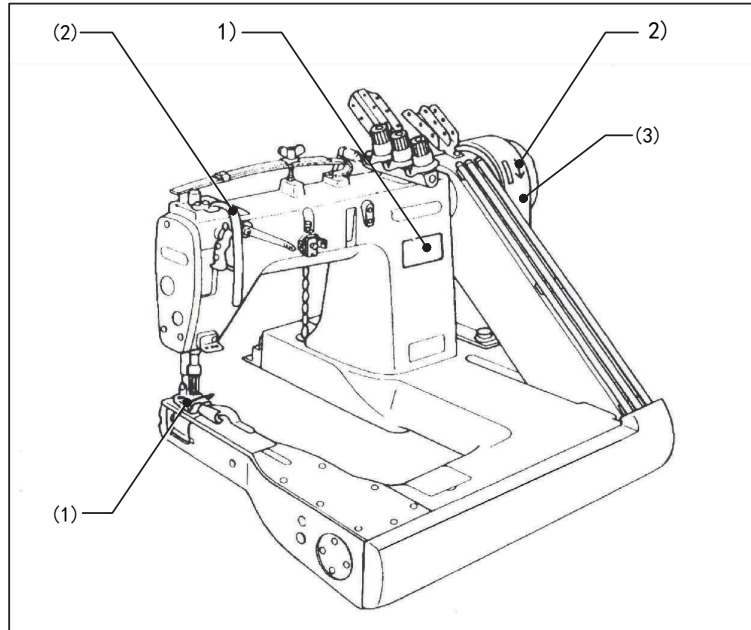

3)、地線標識 Earth wire symbol



- #### 4)、安全裝置 Safety devices
- (1) 護手裝置
Finger guard
 - (2) 引線裝置
Thread take-up cover
 - (3) 皮帶蓋
Pulley cover, etc

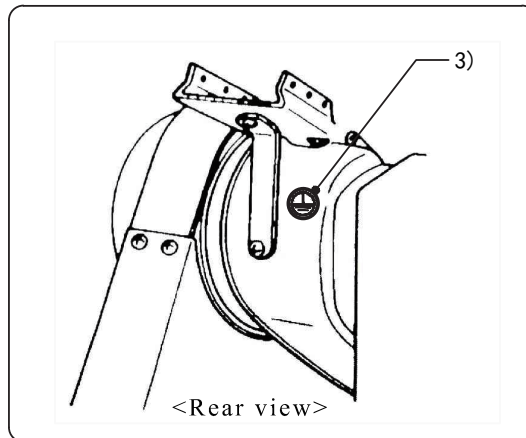

2、零部件名稱 Names of major parts

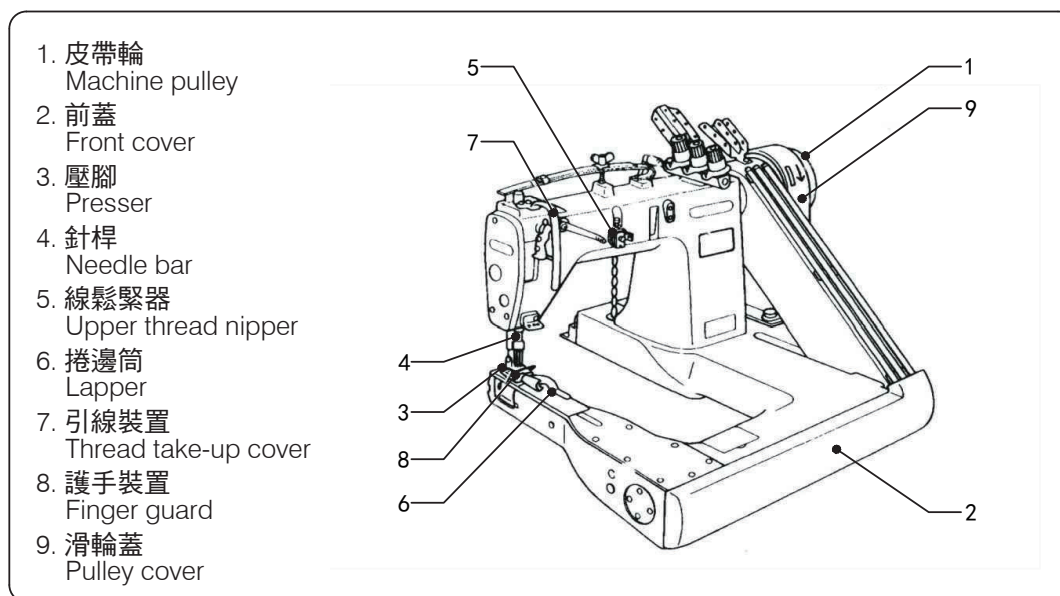

3、機器規格 Machine Specifications

性能規格 Specifications	機種分類 Type			
	雙針薄料 Two Needles Thin Materials	雙針中厚料 Two Needles Medium Materials	三針中厚料 Three Needles Medium Materials	三針厚料 Three Needles Heavy Materials
最高縫速 (針 / 分) Max. sewing speed (spm)	3800	3800	3500	3500
最大線跡長度 (m) Max stitch length (mm)	3.8	3.8	4.8	4.8
壓腳膝提高度 (mm) Feed dog lift height	≥10m	≥10m	≥10m	≥10m
縫製範圍 Stitch Characteristic	薄料 Thin Materials	中厚料 Medium Materials	中厚料 Medium Materials	厚料、極厚料 Heavy Materials
採用機針 Needle	TVx64 14#	TVx64 18#	TVx5 18#	TVx5 21#
採用縫線規格 Thread Type	14 ~ 7.3 tex x3(42~80 支 / 3 股), 棉縫線或滌綸縫線			
針間距 (標準) Needle gauge (Standard)	6.35mm	6.35mm	3.17mm	3.17mm
採用電機 Motor	2P/400W 縫紉機專用電機 或 550W(伺服) 直驅電機 2P/400W Motor OR 550W(Servo)Direct Drive Motor			

正常轉速：雙針 3200 針 / 分 三針 3000 針 / 分
Normal sewing speed (spm): Two Needles 3200 Three Needles 3000

- | | |
|---|------------------------|
| ① 線架安裝孔
Cotton stand Install Bore | ④ 皮帶槽
Belt Slot |
| ② 電機安裝孔
Motor stand Install Bore | ⑤ 抬壓腳鏈條孔
Chain bore |
| ③ 機器側面鉸接固定孔
Machine connect stand Install bore | ⑥ 線纜穿孔
Cable bore |

2)、電機與皮帶
Motor and V-belt

⚠ 注意 / CAUTION

- ❗ 所有與電機連接的電源插頭要確保與其它任何移動物品保持至少 25mm 的距離。
All cords which are connected to the motor should be secured at least 25mm away from any moving parts.
- ⊘ 不能過於用力擠壓插頭，不能用鐵制鉤環固定電線、電纜，以避免引發火災等事故。
Furthermore, do not excessively bend the cords or secure them too firmly with staples, otherwise there is the danger that fire or electric shocks could occur.
- ❗ 安裝與使用電機相配的正確的皮帶蓋。
Install the correct belt cover which corresponds to the motor being used.
- ❗ 請保證接地線的正確、有效連接，以避免電事故的發生。
Be sure to connect the ground. if the ground connection is not secure, serious electric shocks will result.

- (1) 正確選擇電機。
Select the correct motor from those listed in the above table.
- (2) 安裝使用時，務必參照電機使用手冊正確操作。
Refer to the instruction manual for the motor for details on installing and using the motor.

電機 / Motor		
單相 Single-phase	兩極 2-pole	400W 電機 , 400W motor
三相 Three-phase	兩極 2-pole	400W 電機 , 400W motor
(伺服) 直驅電機 550W (Servo)Direct Drive Motor 550W		

- (3) 電機動力與 V 型帶
Motor pulley and V-belt

動力 O.D./ Pulley O.D	85	90	95	100	105	110	115	120	125	130
皮帶的尺寸 (英寸) Belt size (inches)		← M45 →			← M46 →				← M47 →	
縫速 (分 / 轉) Sewing speed (spm)	50HZ				3100			3600		4000
	60HZ	3100			3600		4000			

- (4) 皮帶為 M 類 V 型帶
The belt should be an M-type V-belt.

5、安裝 Installation

1)、機器安裝簡述。

Installation of sewing machine

- (1) 用附件裡面兩組 M12 的螺釘、墊片，把滑輪基座與機器相聯接。
Use two sets of bolt of M12, mat slice of the inside of the enclosure, the pulley base and the machine mutually allied connect.
- (2) 將三件圓柱形減震橡膠墊塞入機器底座內，再將機器置於台板上。
Reduce three cylinder form earthquake rubber mat to stuff into a machine base, place machine again at the bedplate.
- (3) 用附件裡面的三套角鐵、螺釘支架按圖示將機器固定在台板上。
Three sets of Cape iron, bolt support used the inside of the enclosure press the diagram to show machine fix on the bedplate
- (4) 按圖示將皮帶護置固定在滑輪基座上。
Press the diagram to show to protect leather belt to place fix on the pulley base
- (5) 機器固定安裝時確保電機皮帶輪與機器滑輪儘量平行，且無明顯偏差。
Assuer the motor belt orller and machine roller in a same lever when fixing the machine.

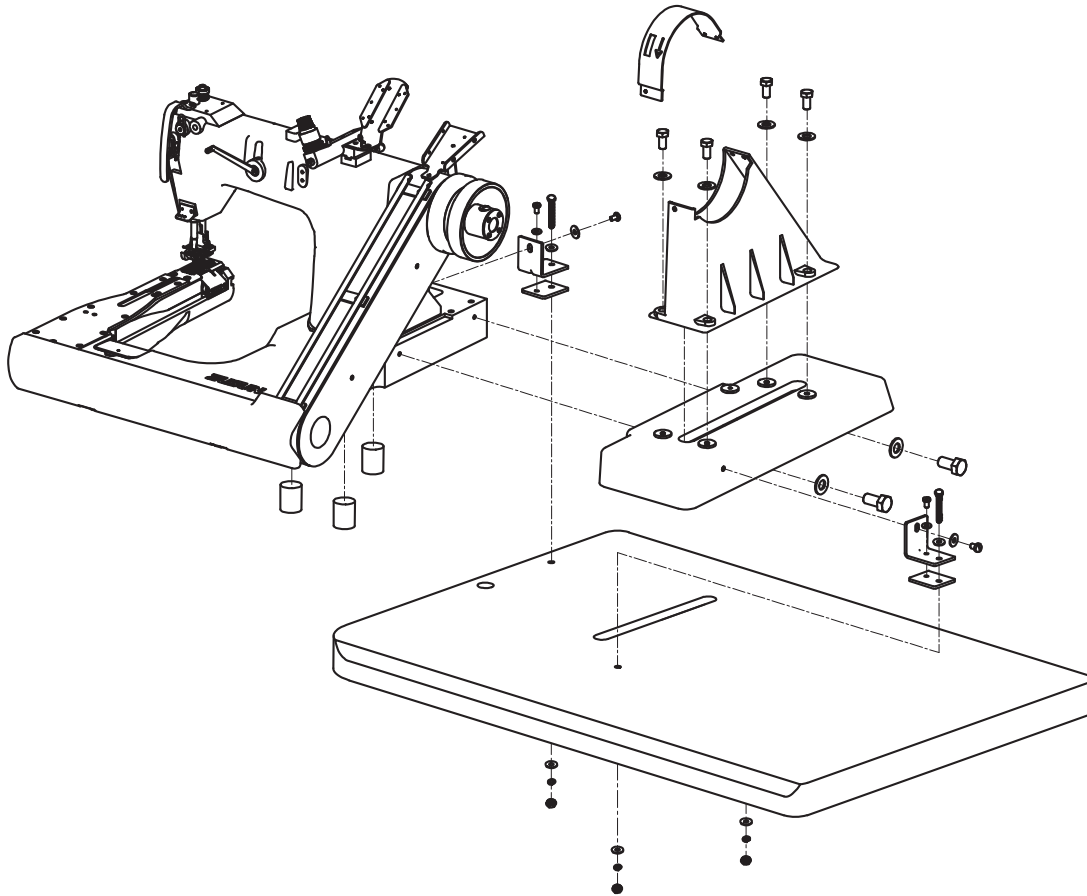

普通曲腕機機器台板安裝示意圖

The common machine bedplate press to pack sketch map

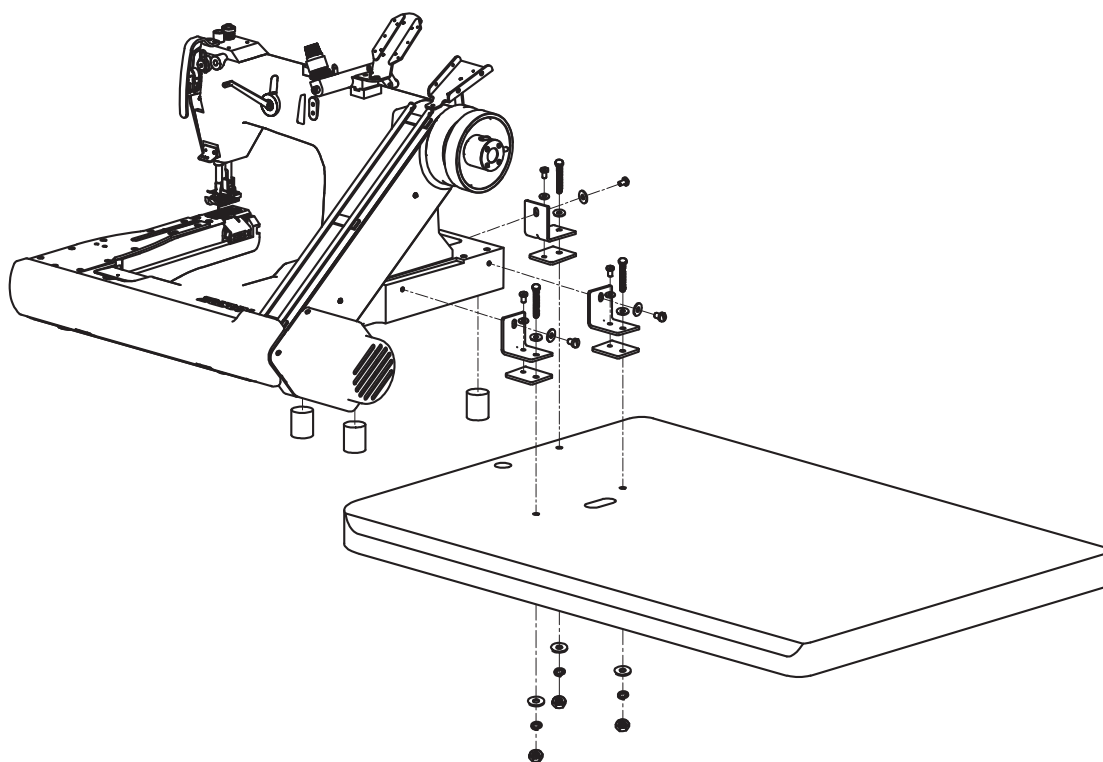

(伺服) 直驅曲腕機機器台板安裝示意圖
 (Servo) Direct Drive machine bedplate press to pack sketch map

⚠ 注意 / CAUTION

- ⊘ 需由專業技術人員安裝機器。
 The sewing machine should only be installed by a qualified technician.
- ⚠ 安裝佈置電線、電纜時需向附近的經銷商或電工諮詢有關線路的安置問題。
 Ask your SiRUBA dealer or a qualified electrician for any electrical work that may need to be done.
- ⚠ 由於機器品質較重，安裝時務必要兩人以上共同作業。
 The sewing machine weighs more than 49 kg. The installation should be carried out by two or more people.
- ⚠ 安裝完畢後，確認電氣線路的安全及機器各運動零部件無干涉或阻礙運動的物體。
 Do not connect the power cord until installation is complete, otherwise the machine will operate if the treadle is pressed by mistake, which could result in injury.
- ⚡ 確保地線的正確、有效連接，以避免可能引發的電擊事故。
 Be sure to connect the ground. if the ground connection is not secure, serious electric shocks will result.
- ⚠ 確保皮帶護罩、滑輪罩殼的安裝。
 Install the pulley cover to the machine head.

2)、安裝機頭

Installing the machine head

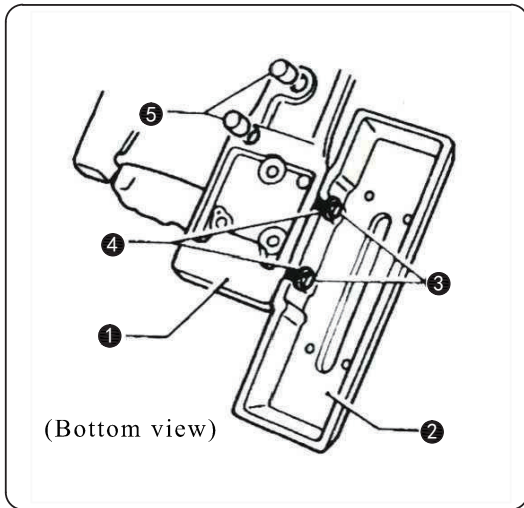

(1) 機座①與滑輪基座②拼接，擰上六角頭螺栓③ (兩件)，螺栓上放置平墊圈④ (兩件)。
Install pulley cover base② on machine bed① with two hexagonal bolts③ and two washers④

(2) 機座底部塞上減震橡膠塞⑤
Insert two bar cushione⑤ into the bottom of the bed.

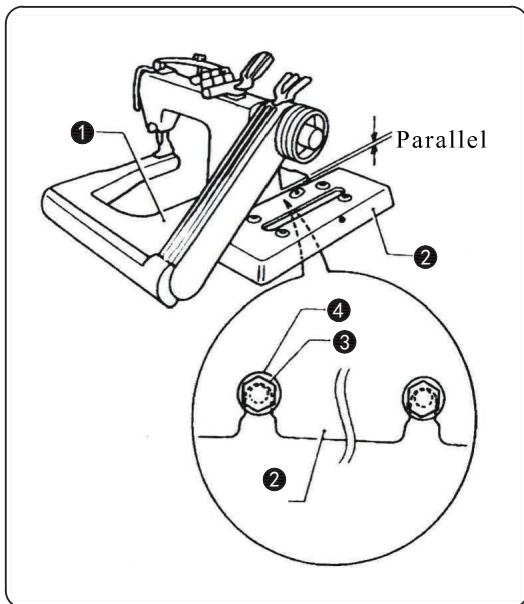

* 將六角螺栓③擰緊，檢查滑輪基座②是否與機器底座①平行
At this time install the two hexagonal bolts③ so that they go as far as possible into the notches in the pulley cover base②.
Furthermore, check that the pulley cover base② is parallel to the bed.
(if it is not parallel, the pulley cover may touch the machine pulley.)

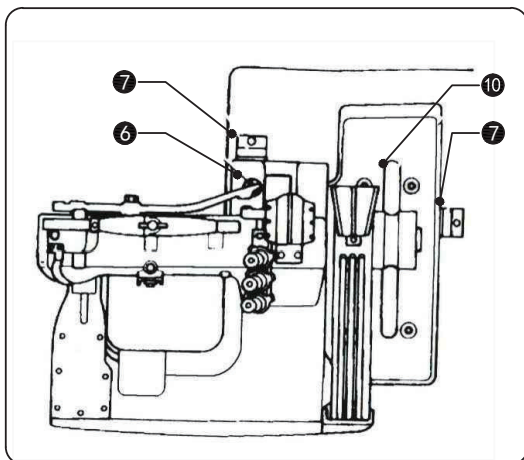

(3) 將機頭放置上台板上，向前後方面調整機器的位置使其位置與抬壓杆鏈條⑥及皮帶安裝孔⑩協調
Place the machine head on table adjust its position in forward and backward directions by aligning it with the hole for presser bar lifter chain⑥, and in sidewise directions by aligning it with belt hole⑩.

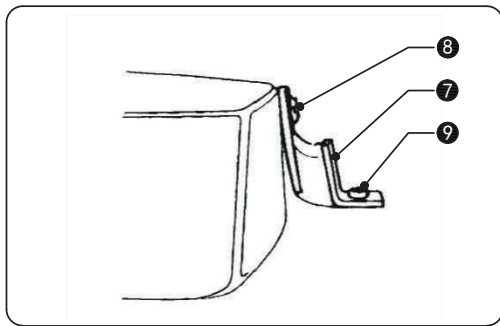

(4) 機器底座塞上減震橡膠塞，安裝好皮帶護罩後，把機器固定在台板上。

After fastening cushions 7 to the machine bed and pulley cover base with set screws 8, fix them to the table with screws 9.

* 安裝機器及台板時，使機器盡可能保持水準狀態。若機器不能水平放置，可能會使潤滑油達不到運動部件，引響機器潤滑。

Place the work table so that the machine h-head is horizontal.

If the machina head is not horizontal lubri-cation will not be carried out correctly.

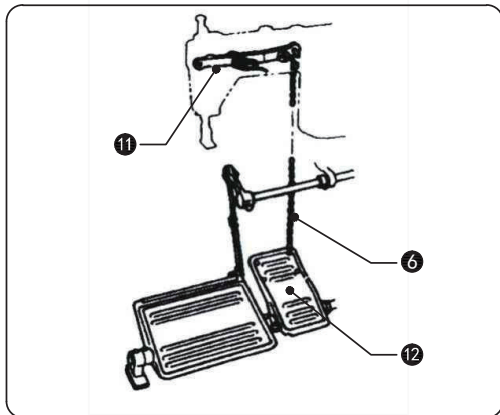

(5) 連接好抬壓腳鏈條 6 壓杆 11 及腳踏板 12。

Connect the presser bar lifter chain 6 to t-knee lifter lever 11 and the presser lifter pedal 12.

3) 地線連接

Ground wire connections

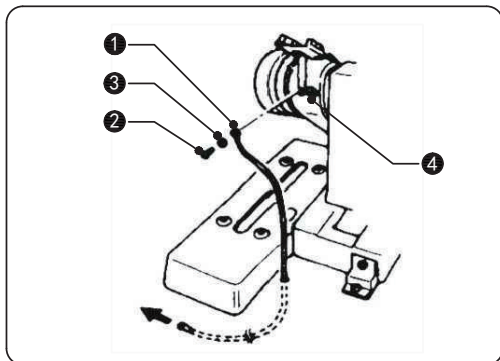

(1) 按照圖示位置正確的連接地線與電機。

Connect the ground wire to the sewing machine head and motor.

(Use the correct type of ground wire and washer)

Remove lower thread guide holder screw 2.

Secure the ground wire 1 to the sewing machine head with screw 2 and washer 3.

Pass the ground wire 1 through the hole in the table.

Connect the ground wire 1 to the motor in accordance with the instructions in the instruction manual for the motor.

4) 安裝皮帶輪及護罩

Installing the pulley cover

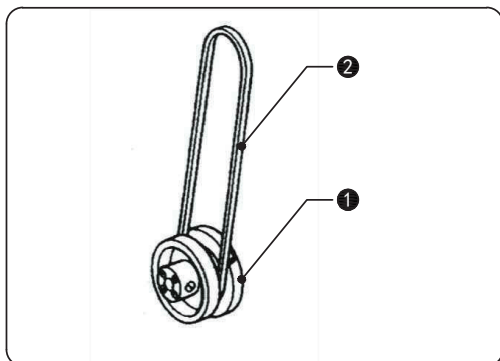

(1) 把皮帶裝在皮帶輪上

Place the belt 2 onto the machine pulley 1.

* 安裝時，皮帶朝上方拉

Pull the belt 2 upward when installing pulley cover A 3.

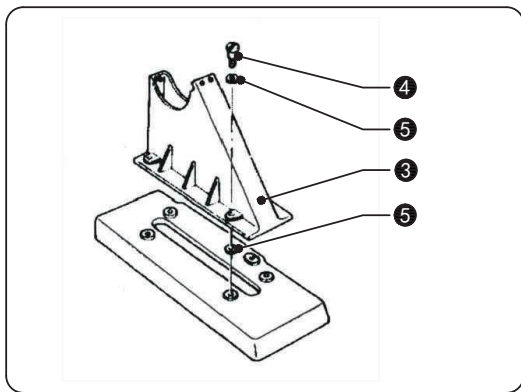

- (2) 安裝皮帶護罩③, 旋上螺絲④。

Place pulley cover A③ so that it is in between the eight pulley cover seats⑤, and then secure it to the pulley cover base with the four screws④.

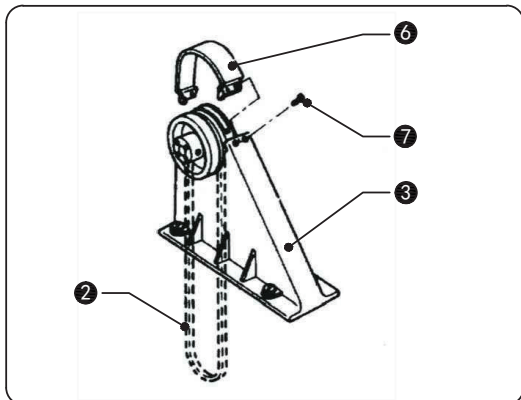

- (3) 把皮帶向下拉, 安裝上皮帶護罩板⑥。

Push the belt② downward, and then install pulley cover B⑥ to pulley cover A③ with the three screws⑦.

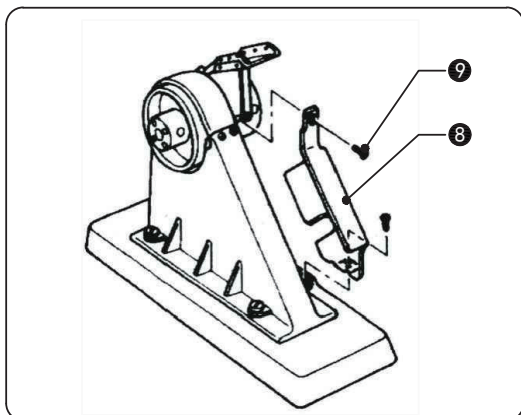

- (4) 若機器配有變速器皮帶護罩⑧附件, 安裝上變速器皮帶護罩⑧, 旋上螺絲⑨。

If the machine is being used with the puller attached install the puller belt cover⑧ with the two screws⑨.

5)、皮帶鬆緊的調節。 Belt tension adjustment

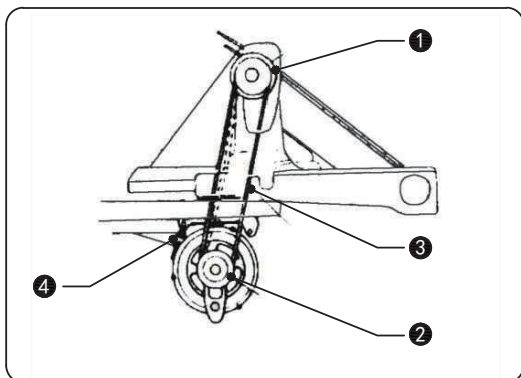

- (1) 安裝 V 型帶③於電機皮帶輪②與機器皮帶輪①之間。

Place the V-belt③ onto the motor pulley②.

- (2) 調節電機上下調整螺母④, 使以 10N 的力在皮帶的中間按下, V 型帶產生約 20mm- 30mm 的間距。
Turn the two nuts④ to adjust so that there is 20 ~ 30mm of deflection in the V-belt 3 when it is pressed at the midway point with a force of 9.8N(1kgf).

6)、線架的安裝
Cotton stand

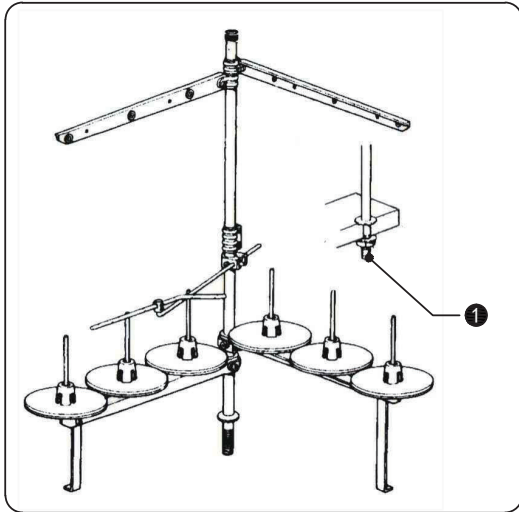

- (1) 按照線架組裝說明書組裝好線架。
Assemble the cotton stand while referring to the cotton stand instruction manual.
- (2) 把線架安裝在台板線架固孔上 ❶。
Install the cotton stand to the cotton stand mounting hole in the work table with nut ❶.

7)、安裝皮帶輪罩殼
Lubrication

⚠ 注意 / CAUTION

- ⊘ 加油時，務必帶上護目鏡和手套，以免油不慎掉入眼睛或是沾到皮膚，而造成傷害。
Be sure to wear protective goggles and gloves when handing the lubricating oil gets into your eyes or onto your skin. otherwise inflammation can result.
在任何情況下，切勿飲用潤滑油，否則會導致嘔吐和腹瀉。
Furthermore, do not drink the oil under any circumstances as it can cause vomiting and diarrhoea.
潤滑油要放在兒童夠不到的地方。
Keep the oil out of the reach of children.

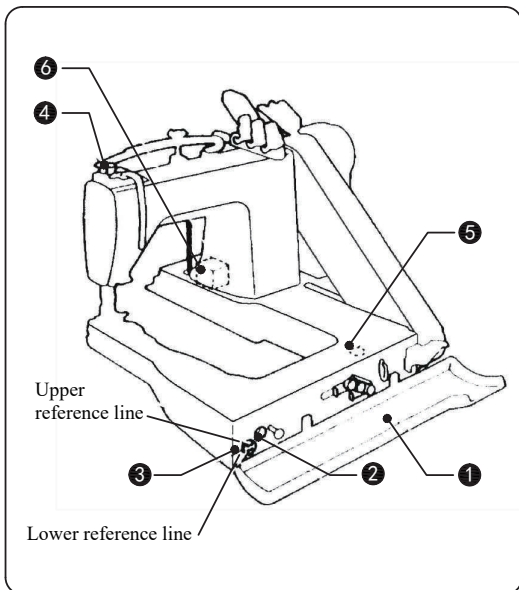

* 需定期給機器加潤滑油，在機器使用或不使用時，都要保持其有一定的油量，使其在使用時能更好的潤滑。

The sewing machine should always be lubricated and the oil supply replenished before it is used for the first time and also after long periods of non-use.

* 請使用推薦的潤滑油。

Use only the lubricating oil (Nisseki Sewing Lube 15) specified by SiRUBA.

- (1) 打開前蓋，取下橡膠塞，往機體裡面加注潤滑油，直至油量達到油箱指示標籤。

Open the front cover ❶, remove the rubber plug ❷ and then fill with oil until the oil level reaches the point in between the reference lines on the oil gauge ❸.

* 若油量低於指示標籤，請務必再往機體內加注潤滑油。

Use only the lubricating oil

(2) 塞上橡膠塞②，蓋上前蓋①。

Insert the rubber plug② and then close the front cover①.

(3) 每週向針柱架的孔內加 1 至 2 滴的潤滑油。

Add 1-2 drops of oil once a week to needle bar bracket lubrication hole④.

(4) 定期旋開機器底座下的排油螺絲，排掉機座內的汙油，排完後旋上螺絲。

Periodically loose the oil drain screw⑤ to drain out any oil which collects in the front bed oil sump. After draining the oil, tighten the oil drain screw⑤.

(5) 定期用乾淨的布清除後機座的油。

Periodically wipe away any oil which collects in the rear bed oil sump⑥ with a cloth.

(6) 轉動機器皮帶輪，使油孔朝上，旋開加油螺釘，加油，請保持油量在中線位置附近。

Turn the machine pulley, so that the oil hole cover⑦ is facing upward, and then remove the oil hole cover⑦ and fill the oil tank⑧ with oil.

(7) 旋上加油螺釘⑪。

Attach the oil hole cover⑪.

* 若是機器配有變速器，旋開變速器頂部加油螺絲，加油至油量尺規的上標線位置。

If the machine is being used with the puller attached, remove the cover screws and fill with oil until the level reaches the upper reference line in the oil sight glass.

* 若是油量低於下標線，務必再加油完畢後，旋上加油螺絲⑪。

If the oil level drops to the lower reference line, be sure to add more oil.

After lubrication is completed, tighten the cover screws⑪.

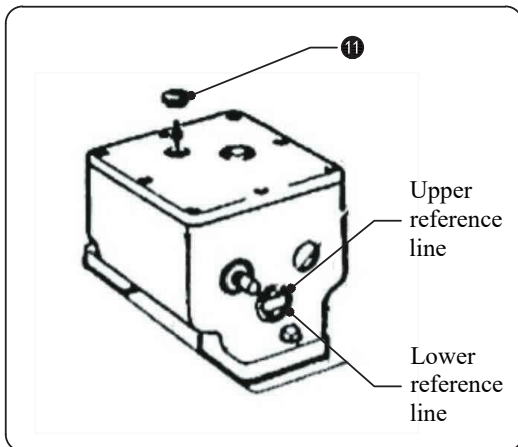
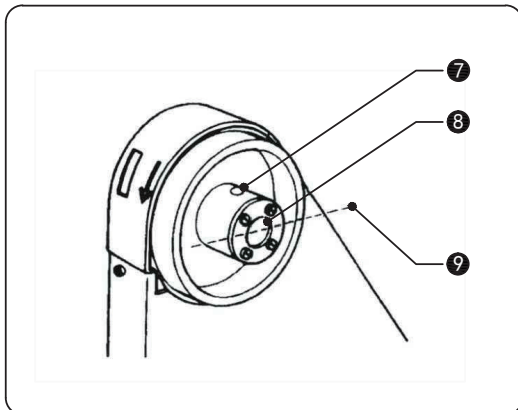

8) 檢測皮帶輪轉動的方向

Checking the machine pulley rotating direction

⚠ 注意 / CAUTION



縫紉時，請不要觸摸運動零部件或替換機器零部件，以免造成人身傷害或機器損壞。

Do not touch any of the moving parts or place any objects against the machine while sewing, as this may result in personal injury or damage to the machine.

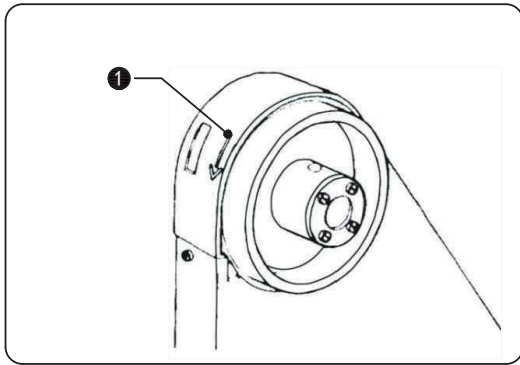

- (1) 插好電源，開啟開關，輕踩下踏板，查看皮帶輪的轉動方向①。
- Insert the power cord plug into the wall outlet, and then turn on the power switch.

* 若是皮帶輪反向轉動，請按照電機說明書重新安裝電機。

If the direction of rotation is reversed, change the direction of rotation to the correct direction while referring to the instruction manual for the motor.

- (2) 在前 3-4 天的使用中，不要使機器運轉轉速高於 2500spm。
- For the first 3-4 days of use, do not run the machine at 500 spm lower than the usual speed. This will help contribute to a longer service life for the machine.

6、縫紉前的準備 Correct Operation

1)、針和線 Needles and Threads

針和線的使用根據縫料而定，請正確使用。

The needle and threads to be used vary depending on sewing conditions. Select the correct ones by referring to the table below.

針 /Needle	線 /Thread	
	上線 /Upper thread	下線 /Lower thread
14#	紗線 #50	紗線 #60
18#	紗線 #30	紗線 #50
21#	紗線 #20	紗線 #30

2)、針的安裝 Installing the Needles

⚠ 注意 / CAUTION



安裝機針前，先關閉電源，以免可能會因誤踩腳踏板而造成傷害。

Turn off the power switch before installing the needle, otherwise the machine may operate if the treadle is pressed by mistake, which could result in injury.

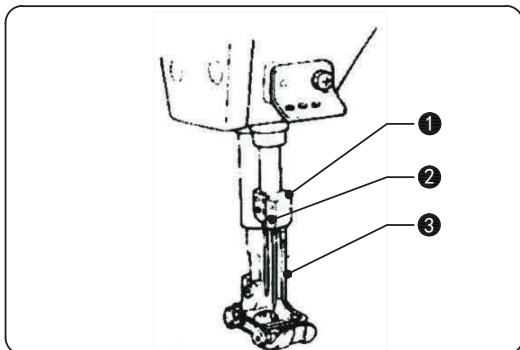

- (1) 轉動皮帶輪直至針夾①到達最高點。
- Turn the pulley until needle holder ① is raised to the highest position.
- (2) 鬆開機針緊定螺釘②，把機針③塞入針夾①的針孔，旋緊緊定螺釘②。
- Loosen needle set screws ②, hold needles ③ with their long grooved side facing front, insert them into needle holder ① all the way, and fasten the needle with needle set screws.

3) 穿引下線

Threading the lower threads

⚠ 注意 / CAUTION



穿線時，先關閉電源，以免機器可能在不慎情況下開啟，造成傷害。

Turn off the power switch before threading the upper thread, otherwise the machine may operate if the treadle is pressed by mistake, which could result in injury.

按照下圖的指示穿線

Pass the lower threads as shown in the figure below.

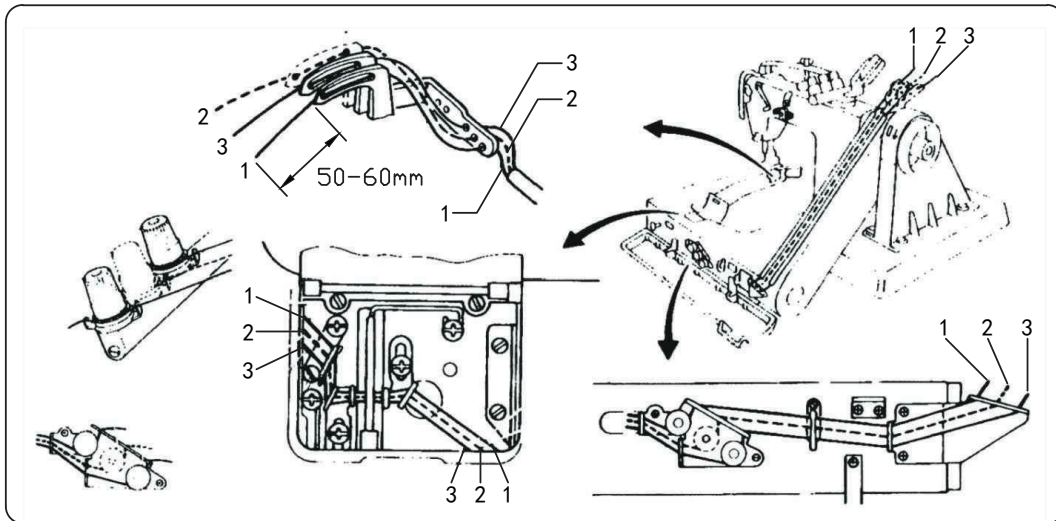

4) 穿引上線

Threading the upper threads

⚠ 注意 / CAUTION



穿線時，先關閉電源，以免機器可能在不慎情況下開啟，造成傷害。

Turn off the power switch before threading the upper thread, otherwise the machine may operate if the treadle is pressed by mistake, which could result in injury.

按照下圖的指示穿線

Pass the lower threads as shown in the figure below.

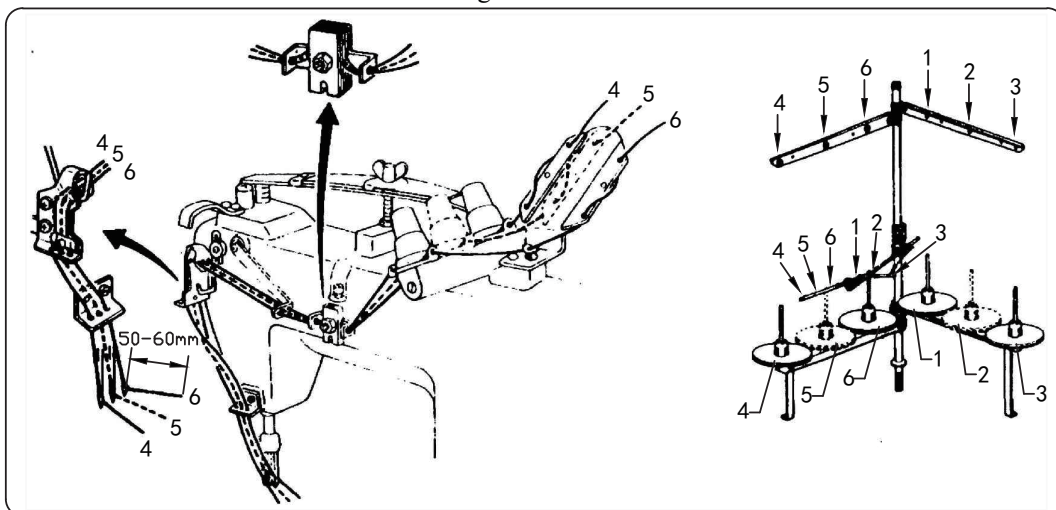

7、縫紉 Sewing

注意 / CAUTION

 務必在使用前安裝好所有的安全裝置，以免造成傷害。
Attach all safety devices before using the sewing machine. If the machine is used without these devices attached, injury may result.

 務必在下麵的操作中切斷電源，以免不慎操作，造成傷害。
Turn off the power switch at the following times, otherwise the machine may operate if the treadle is pressed by mistake, which could result in injury.

穿線時。

When threading the needle.

換針時。

When replacing the needle.

人離開時。

When not using the machine and when leaving the machine unattended.

 縫紉時，請不要觸摸移動件或替換零部件，以免造成人身傷害或是機器損壞。
Turn off the power switch before threading the upper thread, otherwise the machine may operate if the treadle is pressed by mistake, which could result in injury.

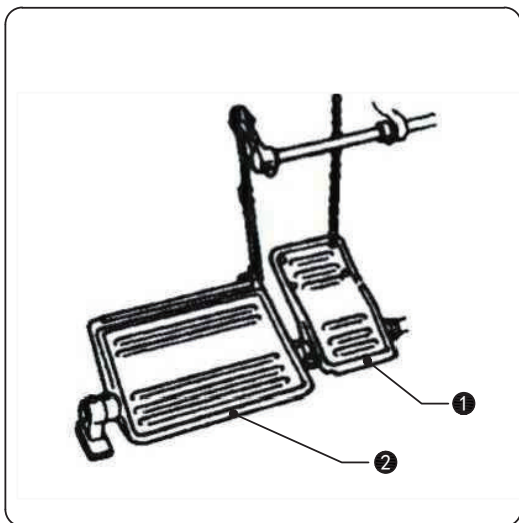

(1) 踩下抬壓腳踏板①抬起壓腳，把縫製件放在壓腳下，鬆開抬壓腳踏板。

Switch the power on, step down on presser for lifter pedal ①, place a fabric under presser foot, and release presser foot lifter pedal ①.

(2) 踩下電機踏板，機器開始運行②。

Depress treadle ② to start the machine.

(3) 縫製結束後，剪斷縫線。

After sewing the work, keep sewing until it reaches thread cutter ③, and then cut the threads with thread cutter ③.

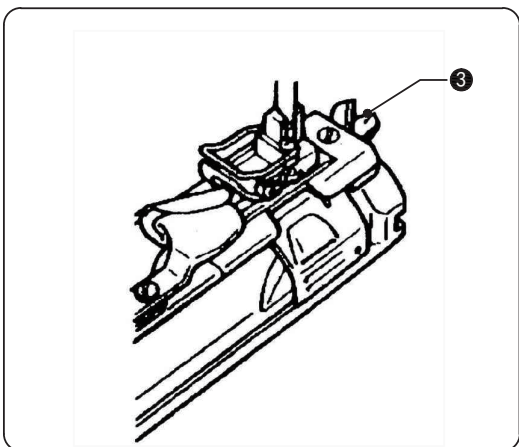

8、縫製的調節 Thread Tension

1)、調節線的鬆緊

Adjusting the thread tension

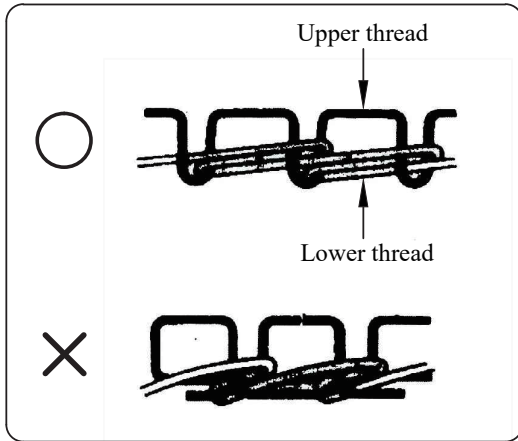

正確的線跡 / Good stitches Adjusting

過鬆的線跡 / Loose , bad stitches

* 根據不同的縫製面料，需要調整麵線、底線的鬆緊，以達到最佳的縫製效果。
Thread tension differs with sewing conditions. Adjust it to suit your particular sewing conditions.

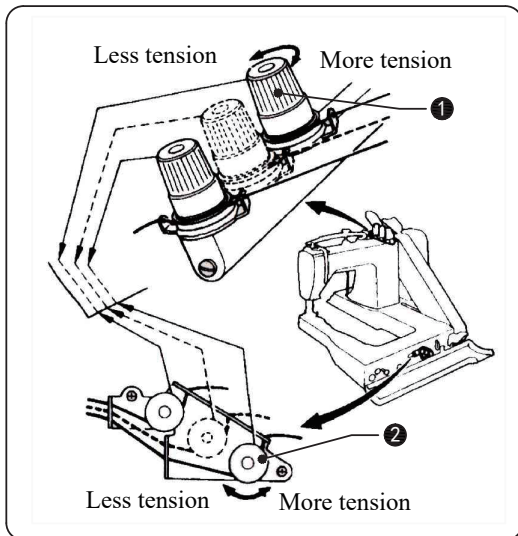

- (1) 旋轉上夾線器組件螺母，調節上線鬆緊。
Adjust the upper thread tension properly by turning upper thread adjusting screw ①.
- (2) 旋轉下夾線器組件螺母，調節下線鬆緊。
Adjust the lower thread tension properly by turning lower thread adjusting screw ②.

2)、壓腳壓力調節

Presser Foot Pressure Adjustment

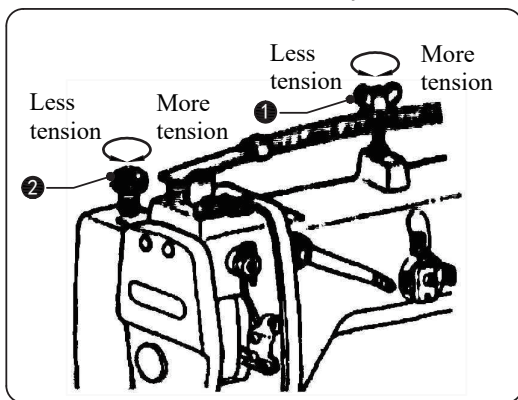

- (1) 通過旋轉調節螺母 ① 調整壓腳的壓力，使壓力滿足合理的縫製作業要求。
Adjust the presser foot pressure by turning wing nut ① to such a level that it is just enough to keep the work from slipping.
- (2) 若機器配有輔助拖輪，拖輪的壓力可以通過調節螺母 ② 進行調節。
In case of Model - SP and - PL the pull-er pressure can be adjusted as appropriate to the work by loosening adjusting thumb- screw nut ②.

3) 調節縫跡的長度 Stitch Length Adjustment

注意 / CAUTION



調節縫跡長度時，先關閉電源，以免機器可能在不慎情況下開啟，造成傷害。
關閉電源後，需確定電機完全處於停止狀態，方可進行調節操作。

Turn off the power supply before adjusting the stitch length, otherwise the machine will operate if the treadle is pressed by mistake, which could result in injury. However the motor will keep turning even after the power is switched off as a result of the motor's inertia.

Wait until the motor stops fully before starting work.

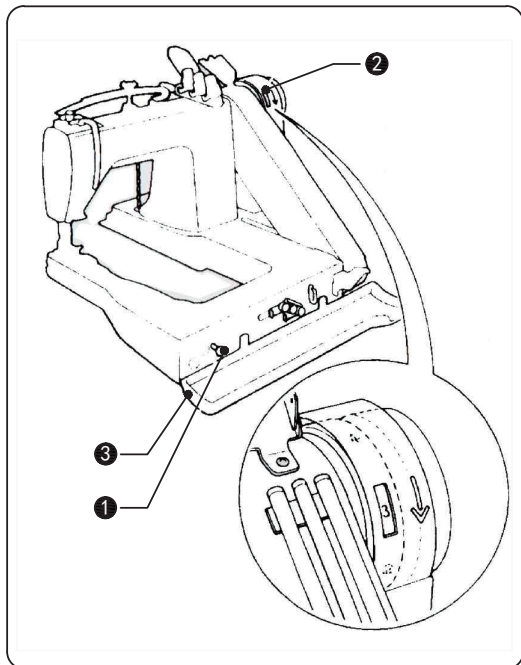

* 機器皮帶輪上顯示的數位表示縫跡的長短，按照縫製的要求，可以調整縫跡的長度。

The numerals on the machine pulley scale represent the stitch length (mm) however the actual stitch length will vary depending on the type and thickness of material being used.

(1) 打開前蓋 ③。

Open the front cover ③.

(2) 按下縫跡寬度調節鈕 ① 後，按箭頭指示方向慢慢轉動皮帶輪。

While pressing the feed adjustment button ①, turn the machine pulley toward you slowly, (The feed adjustment button ① will move further inward.)

(3) 轉到要求的數字，此時，數字對準皮帶輪上蓋的窗口 ②。

While still pressing the feed adjustment button ①, keep turning the machine pulley until the desired numeral appears in the center of the pulley cover window ②.

* 數位越大，縫跡越長。鬆開調節按鈕（確保調節按鈕復位）

The higher the value of the numeral, the larger the stitch length becomes.

Release the feed adjustment button ①.

(Check that the feed adjustment button ① pops back out again.)

(4) 蓋上前蓋

Close the front cover.

注意：

NOTE:

務必在機器完全停止運行後，按下縫跡調節鈕，否則可能損壞機器零部件。

Do not press the feed adjustment button while the machine is operating, as doing so may damage the machine parts.

當把數字調到最大時，必須調節擋針塊，使其與機針保持規定的間距。

When sewing with the stitch length set close to the maximum length, you will need to adjust the needle guard in accordance with the type of material and the type of thread being used.

* 以下表格是在調整托輪裝置時所涉及到有彈性織物和低彈性織物的這示例圖。
 The table below shows samples of stitches made with a highly elastic fabric and a fabric which is not so elastic.
 Adjust the puller feed by referring to this table.

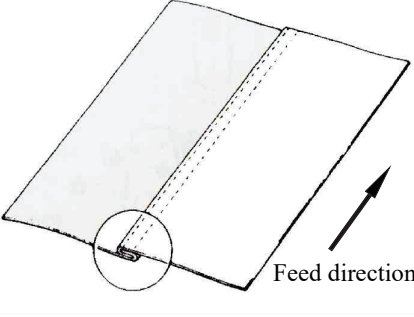
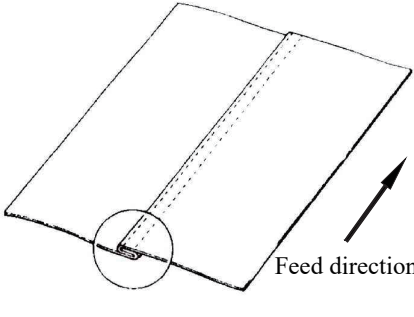
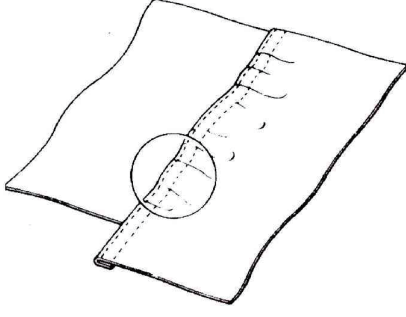
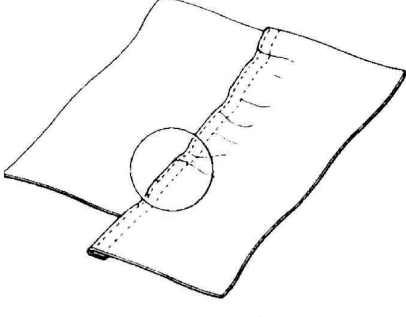
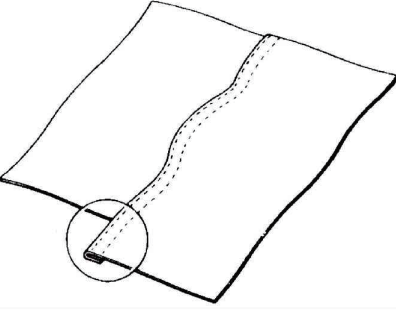
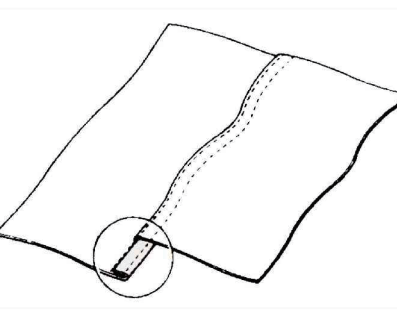
調整拖輪裝置 Puller feed	有彈性織物 Fabric with high elasticity	低彈性織物 Fabric with low elasticity
<p>正確 Correct</p>	 <p>線跡直而且沒有打皺 Neither non-alignment not sewing wrinkles</p>	 <p>線跡直而且沒有打皺 Neither non-alignment not sewing wrinkles</p>
<p>過鬆 Insufficient</p>	 <p>線跡彎曲而且打皺 Non-alignment and wrinkles</p>	 <p>線跡彎曲而且打皺 Non-alignment and wrinkles</p>
<p>過緊 Excessive</p>	 <p>線跡扭曲成波浪形 Non-alignment and very wavy</p>	 <p>線跡扭曲成波浪形 Non-alignment and very wavy</p>

9、清洗處理 Cleaning

- * 為了維護機器的性能和確保機器的使用壽命，必需每天執行以下清洗操作。
The following cleaning operations should be carried out each day in order to intain the performance of this machine and to ensure a long service life.

⚠ 注意 / CAUTION

- ⚠ 清洗之前必須拔掉電源，在電源關掉後由於慣性的結果，電機會繼續轉動，必須等到電機完全停止後才能開始清洗工作，機器在運轉中如果踏板誤踩，可能會導致意外傷害。
Turn off the power switch before carrying out cleaning. The motor will keep turning even after the power is switched off as a result of the motor's inertia. Wait until the motor stops fully before starting work.
The machine may operate if the treadle is pressed by mistake, which could result in injury.
- ⊘ 確保在處理潤滑油的時候戴上防目鏡和手套，以防止油進入眼睛和皮膚而出現症狀，在任何情況下不能飲用此類潤滑油，以免導致嘔吐和腹瀉，謹記此類潤滑油要放在兒童夠不著的地方。
Be sure to wear protective goggles and gloves when handling the lubricating oil, so that no oil gets into your eyes or onto your skin, otherwise inflammation can result. Furthermore, do not drink the oil under any circumstances, as it can cause vomiting and diarrhoea.
Keep the oil out of the reach of children.

1)、日常清洗 Daily cleaning

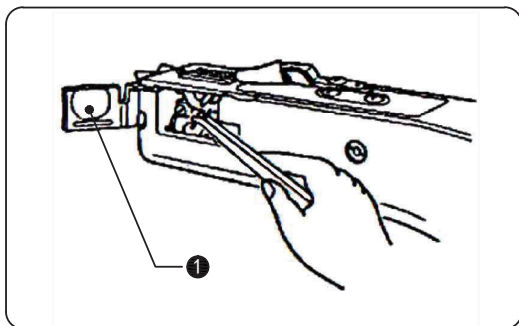

- (1) 打開挑線叉蓋 ① 把裡面的殘留的線屑或雜物清洗出來。
Open the looper side plate and clean away any thread scraps and other rubbish.
- (2) 清洗完畢後，關閉挑線叉蓋。
After cleaning, close the looper side plate ①.
- (3) 檢查
Checking

檢查線是否已正確穿引。
Check that the threads are threaded correctly.
如果針尖已損壞，請更換機針
If the tips of the needles are broken the broken needles.

* 潤滑油至少每三個月更換一次。
The lubricating oil should be changed at least once every three months.

2)、潤滑 Changing the lubrication oil (every three months)

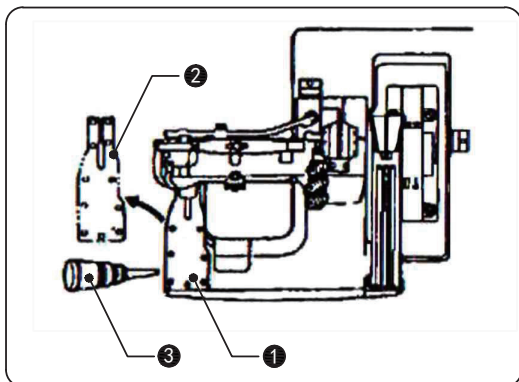

- (1) 擰開前臂蓋螺釘①，打開前臂蓋②。
Remove the 11 screws ①, and then open the forward feed arm cover ②.
- (2) 把機器裡的潤滑油用油壺吸出來③。
Draw up all of the lubricating oil inside the machine into the oil bottle ③.
- (3) 再把油裝進機器，直到在油量表的輔助線範圍。

Fill the machine with oil until the oil level reaches the point in between the reference lines on the oil gauge.

- (4) 蓋上前臂蓋②，擰回前臂蓋螺釘①。
Close the forward feed arm cover② and s-ecure it with the 11 screws①.

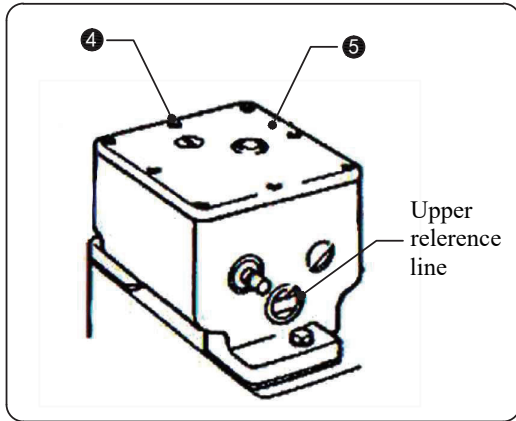

- * 有拖輪裝置的機器
Machines with puller

- (1) 擰開蓋板螺釘④，打開蓋板⑤。
Remove the eight screws④, and then open the puller top cover⑤.
- (2) 把機器裡的潤滑油用油壺③吸出來。
Draw up all of the lubricating oil inside the machine into the oil bottle③.
- (3) 再把油裝進機器，直到在油量表的輔助線範圍內。
Fill the machine with oil until the oil level reaches the point in between the reference lines on the oil gauge.
- (4) 關上蓋板，擰回螺釘。
Close the puller top cover and secure it with the eight screws .

10、調節標準 Standard adjustments

⚠ 注意 / CAUTION

- ⊘ 機器的維護和檢測只能由相關技術人員執行。
Maintenance and inspection of the sewing machine should only be carried out by qualified personnet.
- ❗ 在進行維護、檢測、調整時，請諮詢經銷商或相關技術人員。
Ask your dealer or a qualified electrician to carry out any maintenance and inspec- tion of the electrical system.
- ⚠ 斷開電源同時把電線從電源介面上斷開，否則會因誤踩踏板而轉機器，導致傷害 斷電後，由於慣性電機將繼續處在運轉狀態，此時要等電機完全停止後方可操作。
Turn off the power switch and disconnect the power cord form the wall outlet at t- he following times, otherwise the machine may operate if the treadle is pressed by mistake, which could result in injury.
* 在執行檢查、調整、維護時；在更換易損件，如挑線叉時。
When carrying out inspection, adjustment and maintenance.
When replacing consumable parts such as the looper.
- ⚠ 在做一些調整時，電源開關必須切斷，並且謹慎地遵守安全防範措施。
If the power switch needs to be left on when carrying out some adjustment, be ext- remely careful to observe all safety precautions.
- ❗ 如果安全標識已脫落，必須重新張貼，以確保機器使用時的正確操作。
If any safety devices have been removed, be absolutely sure to re-install them to their original positions and check that they operate correctly before using the mac- hing.

1) 調節針桿

Needle bar height adjustment

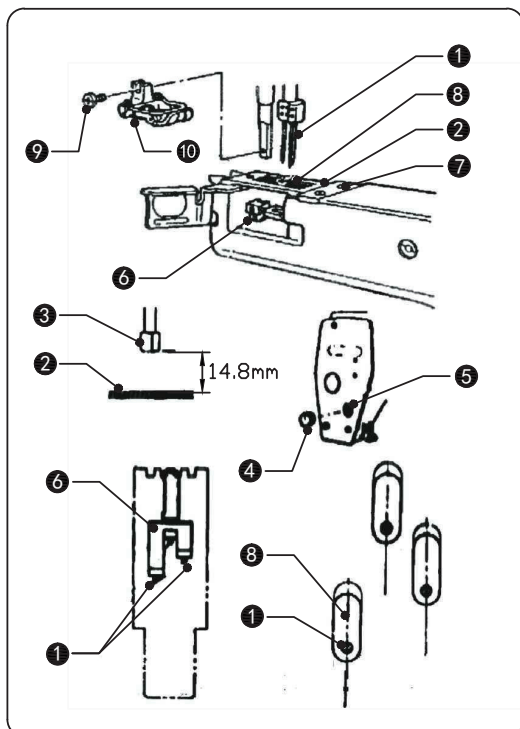

調節機針①的高度，同時調整機針①使每根機針在針板②的針孔⑧中心位置。

Adjust the heights of the needles①.

At this time ,adjust so that each needle① is in the center of the needle hole⑧ in the needle plate②.

- (1) 擰開螺釘⑨，鬆開壓腳⑩。
Remove the screw⑨,and then remove the presser foot⑩.
- (2) 轉動皮帶輪，使針杆下降到其最低位置。
Turn the machine pulley to drop the needle bar to its lowest position.
- (3) 取下橡膠塞④，鬆開針杆抱箍⑤，調整使針夾的底部③距針板②的距離為 14.8mm。
Remove the rubber plug④,loosen the needle bar clamp screw⑤and adjust so that the distance between the botton of the needle clamp③ and the top of the needle plate②is 14.8mm.

* 針夾如上設置，當針夾上升至最高點時，針尖到針板的距離約為 14mm。

If the needle clamp is set in the way described above, the distance between the point of the needle and the top of the needle plate will be 14mm ,when the needle clamp is raised to its highest position.

- (4) 擰開螺釘⑦，取下針板②。
Remove the three screws⑦,and then remove the needle plate②.
- (5) 調整針杆使機針①與擋針塊保持均等位置，調整擋針塊，使機針①與擋針塊⑥之間無手感間隙，擰回螺釘⑦把針板②固定，檢查機針①是否在針孔中心⑧，擰緊針杆抱箍⑤螺釘。
Turn the machine pulley so that the needles①and the needle guard⑥are aligned,and then adjust the tilt of the needle clamp③so that there is no space between the left and right needles①and the needles①and the needle guard⑥at this time.
Install the needle plate with the three screws ,and after checking that the needles are in the centers of the needle holes ,tighten the needle bar clamp screw .
- (6) 塞上橡膠塞④。
Insert the rubber plug④.
- (7) 用螺釘⑨把壓腳⑩按裝在針杆上。
Install the presser foot⑩ with the screw⑨.

2) 調節針和挑線叉 Needle and looper timing adjustment

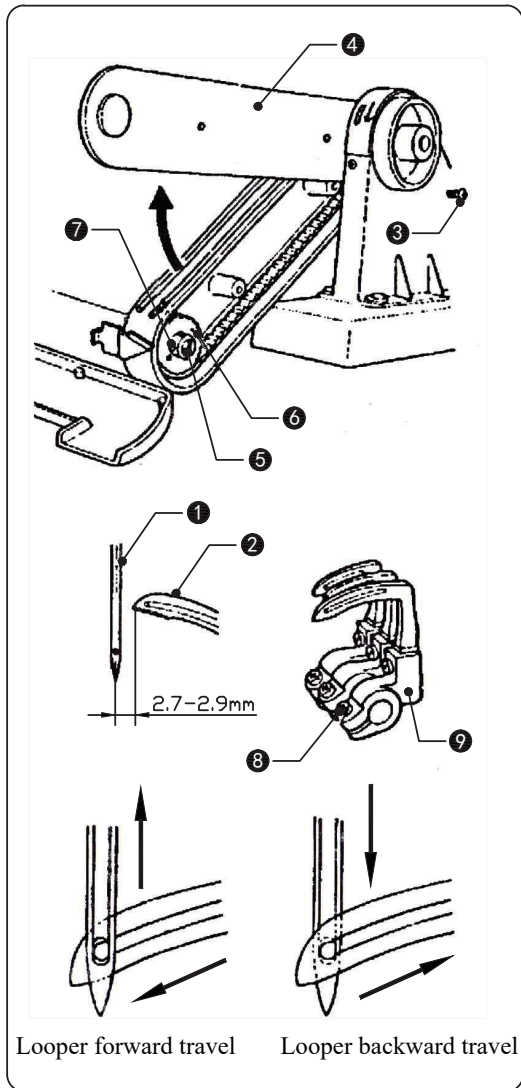

當機針①的位置下降到挑線叉②, 挑線叉向後轉到最後面, 此時機針①的中心位置距離挑線叉②的頂端為2.7-2.9mm。

Make an adjustment so that, when needles are down lowest loopers② reach the end of their backward travel and the distance from the needle center to the looper tip is 2.7 to 2.9 mm.

- (1) 取下壓腳、針板。
Remove the presser foot, needle plate and feed dogs.
- (2) 擰下螺釘③, 打開同步帶蓋④。
Remove the two screws③, and then open the belt cover plate④.
- (3) 轉動皮帶輪, 直至挑線叉②向後並回轉。
Turn the pulley toward yourself until looper② reach the end of their backward travel.
- (4) 鬆開螺釘⑤, 鬆開下同步輪⑥的緊定螺釘⑦。
Loosen cap screw⑤, and then loosen two set screws⑦ on lower belt wheel⑥.
- (5) 轉動皮帶輪直至機針①下降至最低點。
Turn the pulley toward yourself until needles① come down to the lowest position.
- (6) 擰緊同步輪緊定螺釘⑦, 然後擰緊螺釘⑤。
Tighten two set screws⑦ securely, and then tighten cap screw⑤.
- (7) 鬆開螺釘⑧, 轉動挑線叉座⑨, 按箭頭的指示直到機針的中心和挑線叉的頂端距離為2.7-2.9mm。
Loosen set screw⑧, move looper holder⑨ in the arrow direction until the distance between the needle center and the looper tip is 2.7 to 2.9 mm, and retighten set screw⑧ securely.
- (8) 轉動皮帶輪, 確定挑線叉的小孔與針孔基本相稱。
Make sure that the looper thread eyes match the needle eyes in the forward and backward travels of the loopers.
- (9) 裝上同步帶蓋④, 擰緊螺釘③。
Close the belt cover plate④, and then tighten the two screws③.
- (10) 裝上壓腳和針板。
Install the presser foot, needle plate and feed dogs.

3) 調節挑線叉和機針的間隙
Timing of loopers running clear of needles

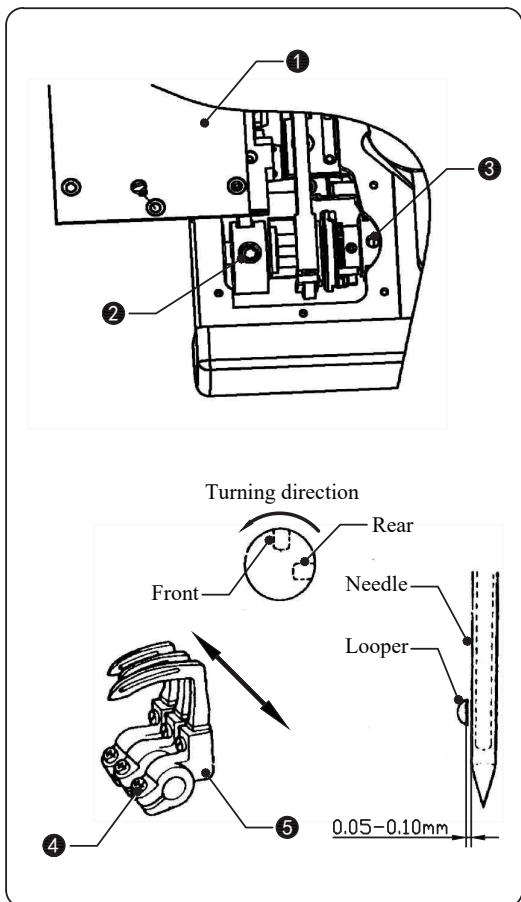

當挑線叉向前運動時，挑線叉應運轉到機針的後面；當挑線叉向後運動時，挑線叉應運轉到機針的前面，在運動過程中，挑線叉與機針的間隙應為 0.05mm-0.10mm 之間。

The loopers run in back of the needle in their forward travel and in front of the needle in their backward travel. Adjust the clearance between the needles and the loopers to anywhere from 0.05 to 0.10 mm in the forward travel.

- (1) 移開前臂蓋。
Remove forward feed arm cover ①.
- (2) 轉動前後方向的偏心輪靠近固定螺釘，與挑線叉偏心調節孔排成一行時，挑線叉的前後應定時調整。調整時，鬆開轉動方向的偏心輪前面的固定螺釘，再鬆開後面的固定螺釘，前後偏心輪就可以調整了，調整後，擰緊兩個固定螺釘。
The forward/back looper timing should be adjusted so that the set screw which is at the rear relative to the forward/back cam turning direction is aligned with the screw adjustment hole ③ when the set screw which is at the rear relative to the up/down cam turning direction is aligned with the looper connecting rod adjustment hole ②. To adjust, loosen the set screw which is at the front relative to the forward/back cam turning direction, and then loosen the set screw at the rear just enough so that the forward/back cam can be adjusted.
- (3) 鬆開固定挑線叉的螺釘，移動挑線叉座，按箭頭方向調整，當挑線叉尖端和機針的中心相稱時，它們的間隙應為 0.05mm -0.10mm 之間。
Loosen the looper holder screw ④, and then move the looper holder ⑤ in the direction of the arrow to adjust so that the clearance between the tip of the looper and the center of the needle is 0.05mm -0.10mm when the two are aligned.
At this time, do not move the looper holder ⑤ in any direction except the direction indicated by the arrow. If it is moved in another direction.
- (4) 安裝好前臂蓋。
Install the forward feed arm cover ①.

4) 調節擋針塊

Needle guard adjustment

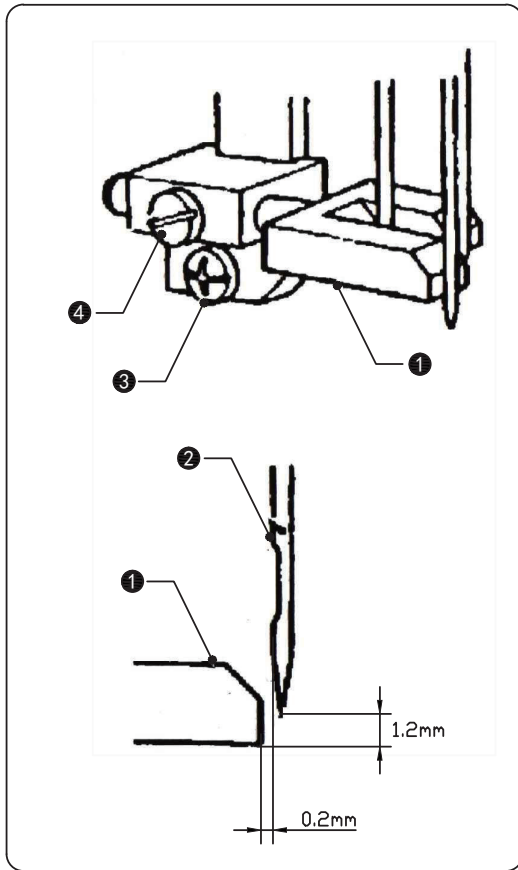

當線跡長度設置最小時，而且挑線叉移向機針時，擋針塊與機針的間隙應為 0.2mm，在不折斷挑線叉的情況下，高度設置的盡可能低一些。

The clearance between the needle guard ① and the needles ② should be 0.2mm when the stitch length is at the minimum setting and the loopers are moving toward the needles.

The heights should be adjusted to as low a setting as possible without the loopers breaking.

- (1) 調整線跡到最小設置。
Adjust the stitch length to the minimum setting.
- (2) 將機器皮帶輪按指示方向旋轉，使挑線叉與機針的中心保持相稱。
Turn the machine pulley toward yourself to align the loopers with the centers of the needles.
- (3) 鬆開螺釘③，然後提升或降低擋針塊使得將針塊的末端到針尖的距離為 1mm-2mm。
Loosen the set screw ③, and then raise or lower the needle guard ① so that the distance from the bottom of the needle guard ① and the needle is 0.2mm.
- (4) 擰緊螺釘③。
Tighten the set screw ③.
- (5) 鬆開螺釘④，然後移動擋針塊向左或向右調整使得擋針塊與機針的間隙為 0.2mm。
Loosen the set screw ④, and then move the needle guard to the left or right to adjust so that the clearance between the needle guard ① and the needles is 0.2mm.
- (6) 擰緊螺釘④。
Tighten the set screw ④.

注意：

Note:

針對有些布料和線，可以得到的最好的縫製效果是當線跡長度調整到實際的線跡長度時，擋針塊與機針輕微接觸。

For some materials and threads, the best results can be obtained if the needle guard and the needle are touching slightly when stitch length is adjusted to the actual stitch length.

5) 送料齒高度的調整
Feed dog height adjustment

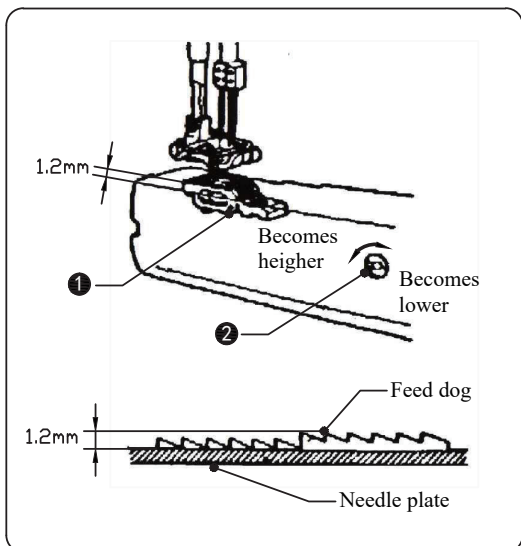

當送料①在最高位置時，調整使送料齒的最高位置處於針板頂面以上 1.2mm。

通過轉動送料杆偏心軸②來調整送料齒高度。

Make an adjustment so that the highest part of the feed dog will be 1.2 mm above the needle plate when feed dog ① is at the highest position.

Adjust the height of feed dog ① by turning feed bar eccentric shaft ②.

6) 調整鬆線杆
Thread release lever adjustment

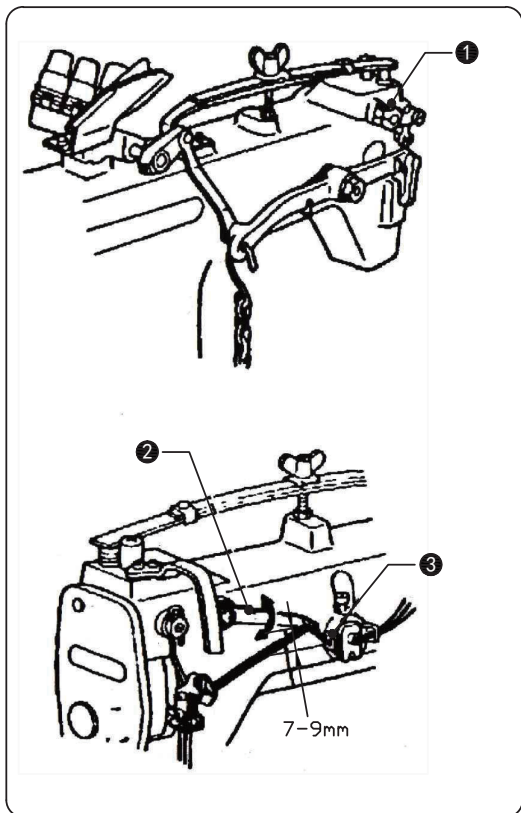

當針杆在最低位置時，調整鬆線杆使之線上壓架上鬆線杆中心的線孔之上 7-8mm。

Adjust so that the center of the thread release lever thread hole is 7-9mm above the center of the thread hole in the upper thread tension bracket when the needle bar is at its lowest position.

(1) 轉動皮帶輪直到針杆向下到最低位置。

Turn the pulley until the needle bar is down at the lowest position.

(2) 鬆開螺釘①，轉動鬆線杆，向上或向下使得鬆線杆中心的線孔線上壓架上部線孔中心之上 7-9mm。

Loosen the screw ① and then move the thread release lever ② up or down to adjust so that the center of the thread release lever thread hole is 7-9mm above the center of the thread hole ③ in the upper thread tension bracket.

(3) 擰緊緊固螺釘①。

Retighten set screw ①.

* 鬆線杆越高，線就越緊。

The higher the thread release lever, the tighter will be the stitches.

7)、調整上打線器

Upper thread take-up thread guide adjustment

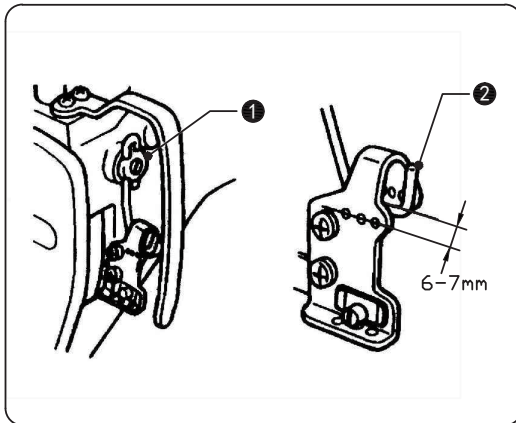

調整上打線器的打線鉤位置，使得和過線板的間距約為 6-7mm 左右。

Adjust the distance between the center of the upper thread take-up and top of the thread guide will be 6-7mm.

- (1) 轉動皮輪直到針杆下降到最低位置。
Turn the pulley toward yourself until the needle bar is down at the lowest position.
- (2) 鬆開螺釘，上下移動打線鉤，使得過線板的過線孔和打線鉤的間距為 6-7mm 左右。
Loosen the screw ①, and then move the upper thread take-up thread guide ② up or down to adjust so that the distance from the top of the upper thread take-up thread guide ② to the center of the upper thread takeup hole is 6-7mm.

* 打線鉤調的越高，麵線線量越大。

The higher the upper thread take-up thread guide ②, the greater will be the upper thread loops.

- (3) 擰緊螺釘 ①。
Tighten the screw ①.

8)、調整上線夾

Upper thread nipper adjustment

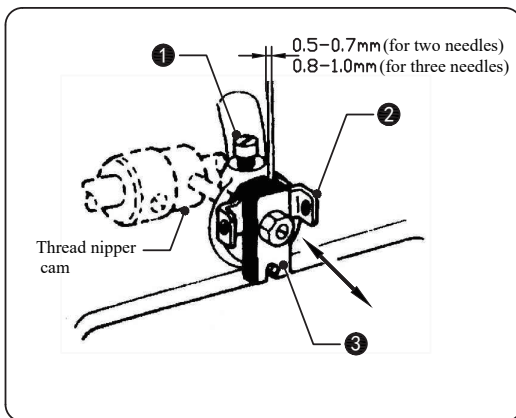

鬆開螺釘 ①，轉動皮帶輪，使得上線夾鬆開時的間隙為 0.5-0.7mm (兩針間隙)；使得上線夾鬆開時的間隙為 0.8-1.0mm (三針間隙)。

Adjust so that the maximum clearance between the upper thread tension bracket ② and the thread tension plate ③ is 0.5-0.7mm (for two needles) or 0.8-1.0mm (for three needles).

Loosen the set screw ①, and then move the upper thread tension bracket ② in or out to adjust so that the maximum clearance between it and the thread tension plate ③ is 0.5-0.7mm (for two needles) or 0.8-1.0mm (for three needles).

* 如果上線夾的夾線板 ③ 上述間隙縮小，將會收緊麵線。

The thread tension will become better if the clearance between the upper thread tension bracket ② and the thread tension plate ③ is reduced.

9) 鬆線軸的調整

Thread release shaft adjustment

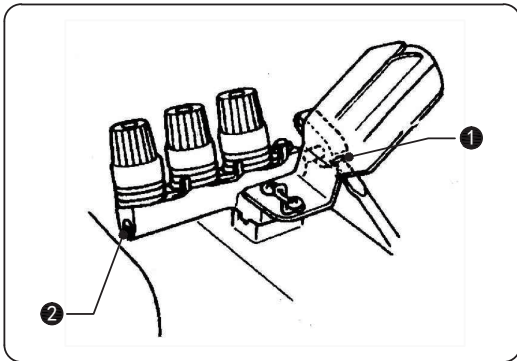

調整鬆線軸使得當壓腳降低時，夾線盤收緊；壓腳提升時，夾線盤鬆開。

Adjust the thread release shaft so that thread tension discs loosen when the presser foot is raised and tighten when the presser foot is lowered.

- (1) 鬆開緊固螺釘①。
Loosen set screw①.
- (2) 通過鬆線軸②調整，當夾線盤鬆開時，使得壓腳提升到距針板 4mm 左右的位置。
Make an adjustment by turning thread release shaft② so that the thread tension discs begin to loosen when the presser foot rises 4mm above the top of the needle plate.
- (3) 調整結束後，擰緊緊固螺釘①。
After the adjustment, retighten set screw① securely.

10) 下打線器調整

Lower thread take-up timing adjustment

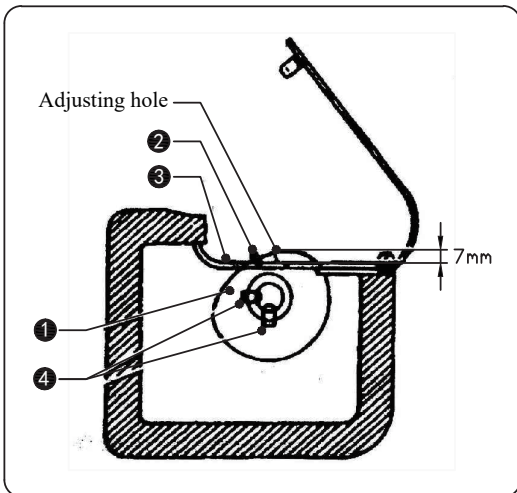

當挑線叉開始向後運動，下打線器接觸到線時，調整使下打線凸輪①在下打線器平面③以上 7mm。

Make an adjustment so that, when the loopers begin moving backward, lower thread take-up① contacts thread②, and is 7mm up from lower thread take-up base③.

- (1) 如圖，鬆開打線凸輪的固定螺釘④。
Insert screw driver through the adjusting hole in the lower thread take-up base, and loosen two set screws④.
- (2) 轉動打線凸輪，直到距打線器平面上 7mm。
Raise lower thread take-up① until it is 7mm up from thread take-up base③.
- (3) 擰緊打線凸輪的固定螺釘④。
After the adjustment, retighten two set screws④ securely.

11) 安裝捲邊器

Installing the lapper

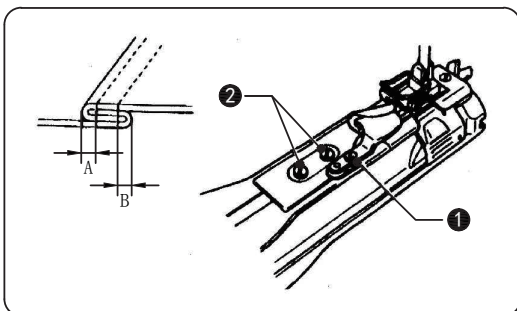

在前臂蓋上，將捲邊器上的導向滑塊，嵌入前臂蓋的滑槽內，使捲邊器前端對正並貼近壓腳。

Insert the lapper guide plate from the front into the oval slot in the forward feed arm cover, making sure that the end of lapper is clear of the presser foot.

* 捲邊器的調節
Lapper adjustment

通過鬆開固定螺釘 ①，調整縫距 A。調整後擰緊固定螺釘 ①。

Adjust felling distance of point A by loosening set screw ①.

After the adjustment, retighten set screw ①.

通過鬆開固定螺釘 ②，調整縫距 B。調整後擰緊固定螺釘 ②。

Adjust felling distance of point B by loosening set screw ②.

After the adjustment, retighten set screw ②.

12) 拖輪高度的調節 (配拖輪的機器)

Puller height adjustment (Machines with puller)

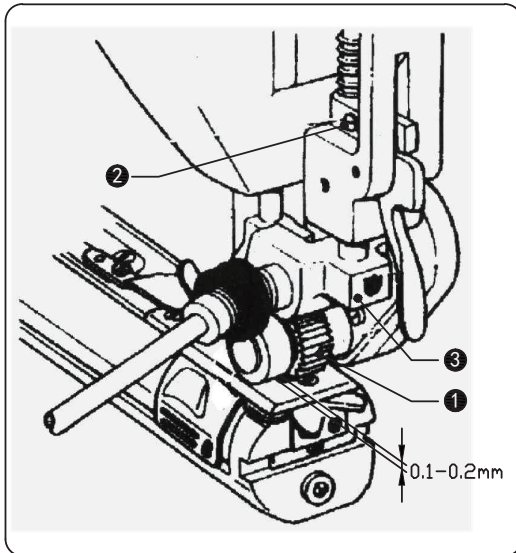

調節拖輪的高度使得它高於針板面 0.1-0.2mm。

Adjust the height of puller ① so that it is 0.1 to 0.2 mm high from the top of the needle plate.

(1) 鬆開固定螺釘 ②，上下移動拖輪支架 ③，使拖輪 ① 在針板平面上 0.1-0.2mm 之間。

Loosen set screw ② and move puller support ③ up or down until puller ① is 0.1 to 0.2 mm above the top of the needle plate.

(2) 調整後，擰緊固定螺釘 ②。

After the adjustment, retighten set screw ②.

13) 拖輪同步的調節 (配拖輪的機器)

Puller timing adjustment (Machines with puller)

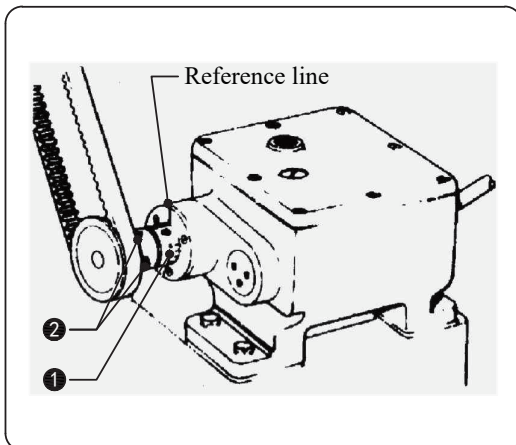

調整使得當針杆向下到最底位置時，刻度盤上的標記 ① 正對輔助線。

Make an adjust so that, when the needle bar is down at the lowest position, the mark on timing collar ① is in line with the reference line.

(1) 轉動機器皮帶輪，直至刻度盤上的標記 ① 正對輔助線。

Turn the pulley toward yourself until the mark on timing collar ① meets the reference line.

(2) 鬆開兩個固定螺釘 ②，轉動機器皮帶輪，直至針杆向下到最底位置。

Loosen two set screws ②, and turn the pulley toward yourself until the needle bar is lowered all the way down.

(3) 擰緊兩個固定螺釘 ②。

Retighten two set screws ②.



高林股份有限公司
KAULIN MFG. CO., LTD.

由於對產品的改良及更新，本產品使用說明書中與零件圖之產品及外觀的修改恕不事先通知！
The specification and/or the equipment described in the instruction book and parts list
are subject to change because of modification with out previous notice
ZSL-04F01.JUN.2023