

銀箭牌

WWW.SIRUBA.COM



SIRUBA

2023 综合目录
GENERAL CATALOGUE



将缝纫之美传至世界各地

DELIVER THE BEAUTY OF SEWING TO ALL OVER THE WORLD

从扛着一台台缝纫机问候客户的当年，到成为台湾第一领导品牌的现在，
每一个脚步都述说着高林坚持不懈，任重道远的使命感。

From the earliest day we carried sewing machines to visit clients on foot,
and now we have become the top leading brand in Taiwan.

Every step we made, presents our solid, unswerving, and responsible commitment.

History

1965 高林股份有限公司正式成立
Kaulin Mfg. Co., Ltd. was founded.

SIRUBA

第一代品牌标志
First LOGO

1971 工业用手提式缝袋口机上市
Introduced industrial portable bag closer machine to the market.

1981 推出工业用超高速拷克车系列产品
Introduced industrial ultra high-speed Overlock Sewing Machines.

1991 工业用三针绷缝机系列产品成功应市
Introduced industrial 3-Needle Interlock sewing machine.

1994 荣获商检局「ISO-9002」国际品保系列认证通过
开发四针与十二针环缝车(VC008)系列产品成功
Passed ISO-9002 International QA System Certification.
Introduced 4 and 12-Needle cylinder bed Chainstitch machine (the VC008 Series).

1996 四针平车(HF008系列)开发成功应市
Introduced 4-Needle Double Chainstitch machine (the HF008 Series).

1998 企业识别(CIS)更新
Corporate Identity System updated.

SIRUBA
工业用缝纫机
INDUSTRIAL SEWING MACHINE

2000 股票上市 (TWSE 1531)
Stock listed in Taiwan Stock Exchange Market. (TWSE 1531)

2005 扩大企业生产规模，投资设立宁波高林银箭机电有限公司
Kaulin Machinery & Electronic industrial (Ningbo) Co., Ltd., was established.

2007 荣获外贸协会第四届“台湾优良品牌”；“台湾精品奖”等奖项

Granted "Taiwan Superior Brands", "Taiwan Excellence" Award, by the Ministry of Economic Affairs.



2011 获颁「台湾百大品牌」殊荣，并参与「台湾精品二十周年暨台湾百大品牌特展」
Awarded "Top one hundred of Taiwan brands" by Ministry of Economic Affairs.



SIRUBA

2013 高林文创基金会成立
Kaulin Foundation established.

2014 成立「缝纫自动化」研发部门
"Sewing Automation Department" established.

2015 推出ASP-EBJ100等数位缝纫自动化设备
Launched "ASP-EBJ100" and various automatic sewing machines.

2016 原有南崁厂为扩大生产规模，搬迁至桃园新厂
Taiwan factory transferred from Nankan to Taoyuan for production scale expanding.

2017 推出集大成的最新款700L包缝机
Launched 700L, the overlock/safety stitch machine which compiles SiRUBA's finest overlock know-how.

2018 SiRUBA ICT 客户服务发展平台元年
First year of SiRUBA ICT Customer Service Platform Development and Implementation.

2019 越南子公司成立于河内
SiRUBA Machinery Vietnam CO., LTD. was founded in Hanoi.

2020 胡志明办公室成立
Ho Chi Minh City Liaison Office established.



最初推出的包缝机
First Overlock Sewing Machine



最初推出的双针平车
First Two-needles Lockstitch Machine



AA-6



700L



C007LX



NC008



ASV-ATS100A

SIRUBA



一指搞定

One click to all access

SIRUBA Connect Service 给您全方位的VIP体验

SIRUBA官方专属APP「SiRUBA Connect」，可以让您快速了解缝纫机产品的生产履历，同时可让您迅速浏览产品相关档案。您也可以利用APP进行产品的线上客户服务。

SIRUBA Connect Service provides you exclusive VIP experience

SiRUBA official APP "SiRUBA Connect", provides convenient doorway to view sewing machine's product history. You can also explore related product documents, and use this app to report to our customer service.



android



ios



android(China)

Download SIRUBA CONNECT SERVICE APP



无远弗届

Service beyond boundaries

SIRUBA 网络商务全面上线

您可以从我们的官方网站上进入我们的网络商务平台，轻松下单缝纫机与相关零件。所有商品都井然有序地分类陈列，并让您透过零件系列图，迅速地找到您所需要的商品。

SIRUBA E-commerce website launched

Now you can do easy order-placing through our E-commerce website, to buy sewing machines and parts. All merchandise are sorted in user-friendly order, and there are parts lists you can refer to find desired item quickly.



MACHINE CENTER ONLINE



PARTS CENTER ONLINE













	制衣工程 APPLICATION	▶ PAGE	2
	PROTECTIVE WEAR / T-SHIRT / POLO SHIRT / SWIMMING WEAR / RIBBED / LINGERIE / MEN'S BRIEF / SPORTSWEAR / SHIRT / LADIES' OUTWEAR / MEN'S TROUSERS / JEANS		
	自动化 AUTOMATIC SEWING MACHINE	▶ PAGE	13
	ASP-EBJ Series / ASV-ATS100 Series / ASK-ASM101 / ASK-ASM200 / ASC-TBH200 / ASP-PTA 101 / ASO-STM100 / ASO- ABF100		
	包缝机  Device	▶ PAGE	31
	OVERLOCK SEWING MACHINE 700LQ / 700L / 700KS / 700KST / 700KT		
	绷缝机  Device	▶ PAGE	65
	INTERLOCK SEWING MACHINE C007L / C007LX / C007KP / U007 / S007K / F007K		
	多针链缝机  Device	▶ PAGE	116
	MULTI-NEEDLE / PICOTING CHAINSTITCH MACHINE VC008A / VC008B / HF008A / NC008 / Z008		
	平缝机 LOCKSTITCH MACHINE	▶ PAGE	140
	DL720 / DL7200C / DL7200D / DL7500 / DT828 / DT828L		
	电子花样机 / 锁眼机 / 套结机 / 钉扣机 COMPUTER-CONTROLLED CYCLE MACHINE	▶ PAGE	158
	PS Series / BT Series / BH-9820 Series / LBHS-1790D / LKS-1900D		
	四针六线并缝机 4-NEEDLE 6-THREAD FLATSEAMER	▶ PAGE	174
	D007SP / D007SXP / D007RB		
	其他 OTHER	▶ PAGE	181
	LZ Series / DL3880 Series / AA		

TABLE OF SPECIFICATION SYMBOLS



针数
Needle numbers



压具扬程
Presser foot lift



自动切线功能
Thread chain cutter



线数
Thread numbers



针板
Needle plate



针距
Max. feeding amount



针距
Needle gauge



切边距离
Gauge width



最高摆针
Max zigzag width



包边宽度
Overedge width

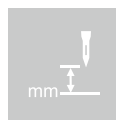

针棒高度(mm)
Needle bar height



缝距
stitch length



车缝距离
stitch length



针棒行程(mm)
Needle bar stroke



包装尺寸
Package Size



差动比
Differential feed ratio



拉布轮数
Puller numbers



重量
Weight



使用针型号
Type of needle

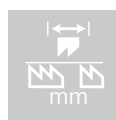

上送具行程
Top Feeding Function



切刀尺寸
Knife size



车缝速
Sewing speed

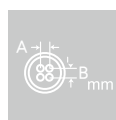

孔位尺寸
Button sewing size



马达
Motor



钮扣尺寸
Button size



General Seaming:

Closing hood, Sleeve, Leg & etc.

737L-504M-3-04

747L-514M-3-24

757L-516M-3-35



Zipper Attaching

DL7200C

DL7200D

DL7500

DL720



Elastic Tape Attaching

737L-504M-3-04/LFC-3

747L-514M-3-24/LFC-3

747L-514M-3-24/SMK

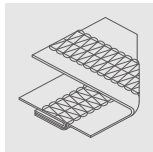

C007KP-W322-356/CC

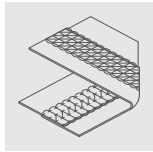

D007SP

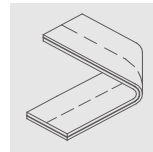

DL7200C
DL7200D
DL7500
DL720

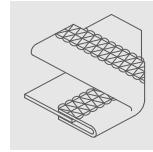

700KS/ACS
700KS/RSK
C007KP-W222-356/CQ
F007K-W222-356/FQ

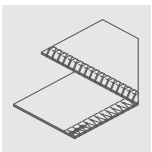

747L-514M-7-23/BK
747L-514M-3-23/BKF1
747L-514M-3-24/BKT

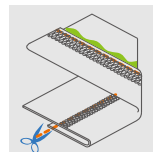

ASC-TBH200
C007KP-W812A-356/CRL
C007L-W812A-356/CRL/RL

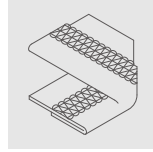

C007KP-W122-356/CH
F007K(D)-W122-356/FHA
C007L/LX-W122-356/CH

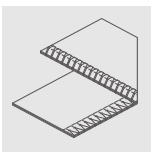

747L-514M-3-24

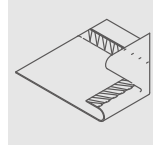

737L-505F-2-04

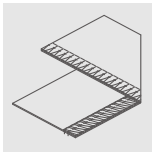

737KS(T)
747KS(T)

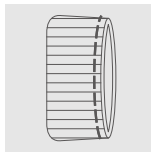

ASK-ASM101

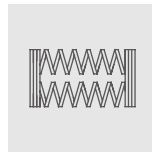

LBHS-1790D

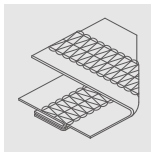

C007KP-W322-356/CE
C007L/LX-W322-356/CE

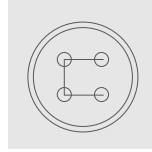

ASO-ABF100
LKS-1903D

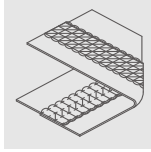

D007SP

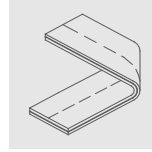

DL7200C
DL7200D
DL7500
DL720

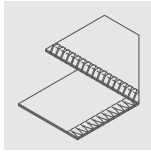

747L-514M-3-24/TG

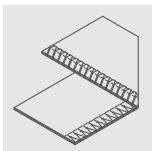

747L-514M-3-24
747L-514M-7-23/BK
747L-514M-3-23/BKF1
747L-514M-3-24/ECA/BKT

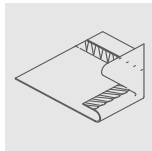

737L-505F-2-04

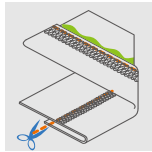

C007KP-W812A-356/CRL
C007L/LX-W812A-356/CR

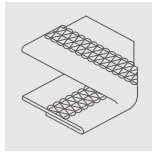

C007KP-W122-356/CH
C007L/LX-W122-356/CH

**POLO
SHIRT**

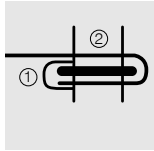
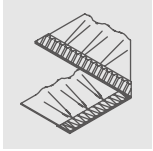

737KS(T)
747KS(T)
747L-514M-3-24/LFC-3
747L-514M-3-24/LFD-6
C007KP-W122-356/CH
C007L/LX-W122-356/CH

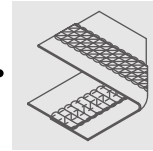

D007SP



SWIMMING
WEAR

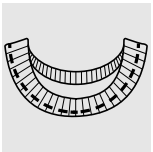

747KST-514M-3-24/VT/ACS

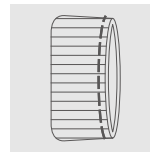

ASK-ASM101



ASK-ASM200

RIBBED

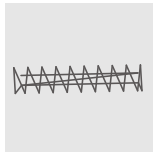

LKS-1900D

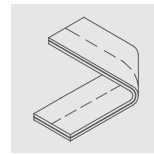

DL7200C
DL7200D
DL7500
DL720

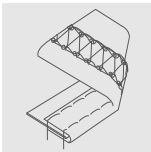

F007K-W522-232
/FR/FQS

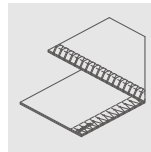

747L-514M-7-23/BK
747L-514M-3-23/BKF1
747L-514M-3-24/ECA/BKT

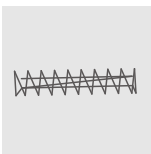

LKS-1900D

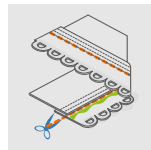

C007KP-W522-356/CR/FFC
F007K-W522-356/FR/FFC

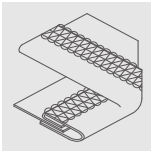

C007KP-W152-356/CZ/RLQ

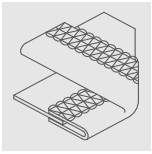

C007KP-W222-356/CQ
F007K-W222-356/FQ

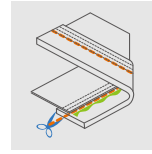

C007KP-W532-356/CR/CX/UTP/RLP

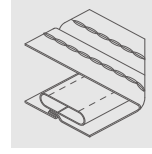

F007K-U712(A)-264/FSP
F007K-U712-496/FSS

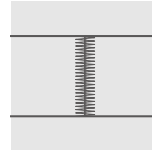

ASP-EBJ100
ASP-EBJ200

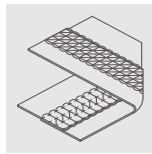

D007SP
F007K-W922-456/FW
C007KP-W922-456/CW

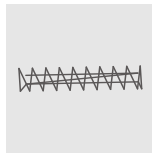

LKS-1900D

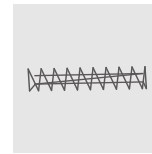

LKS-1900D

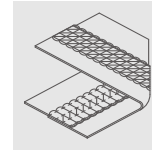

D007SP
F007K-W922-456/FW
C007KP-W922-456/CW

MEN'S BRIEF

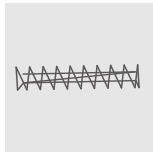

LKS-1900D

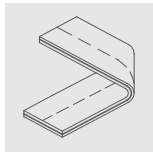

DL7200C
DL7200D
DL7500
DL720

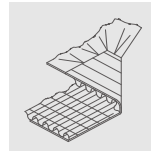

VC008A-04095P/VWL
VC008A-04095P/VWLB
VC008A-04095P/VWLC

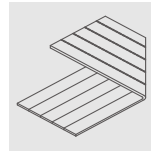

VC008A-04085P/VCE
VC008B-04085P/VCE

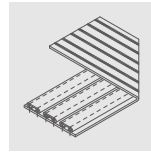

VC008A-06048P/VPL
VC008B-06048P/VPL

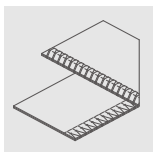

747L-514M-3-24

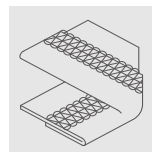

C007KP-W122-356/CH
C007L/LX-W122-356/CH

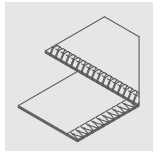

757L-516M-3-35

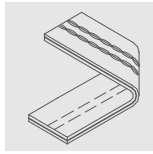

DL3882

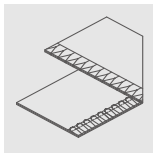

747L-514M-3-24

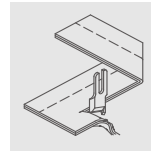

DL7200C-RM1

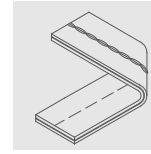

DL3881

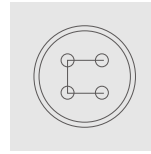

**ASO-ABF100
LKS-1903D**

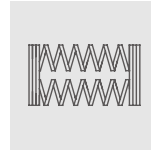

LBHS-1790D

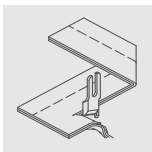

DL7200C-RM1

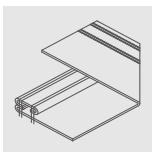

VC008A-0464-191P/VSF

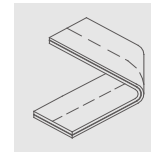

**DL7200C
DL7200D
DL7500
DL720**

SHIRT

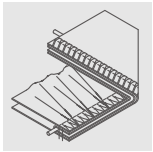

747L-514M-8-24/GA

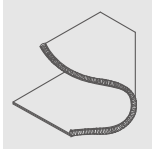

737L-504F-2-02/GAL

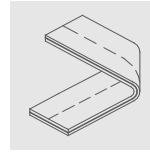

**DL7200C
DL7200D
DL7500
DL720**

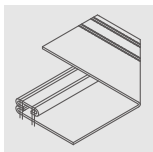

VC008A-0464-191P/VSF

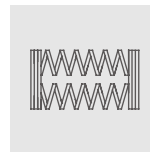

LBHS-1790D

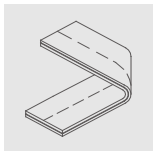

**DL7200C
DL7200D
DL7500
DL720**

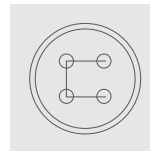

**ASO-ABF100
LKS-1903D**

LADIES' OUTWEAR

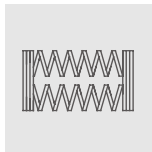

LBHS-1790D

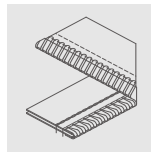

757L-516M-3-35/PS
757L-401M-8-50/TA

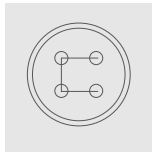

ASO-ABF100
LKS-1903D

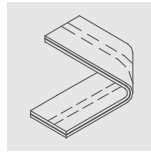

DT828
DT828L

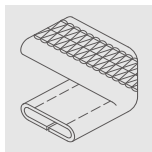

F007K(D)-U613-256/FBP

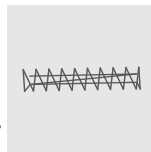

LKS-1900D

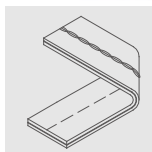

DL3881



BH-9820

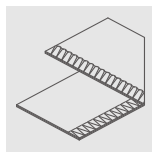

737L-504M-3-04
757L-516M-3-35

MEN'S TROUSERS



AUTOMATIC SEWING MACHINE

AS P - EBJ 100 □

搭配机种 Model
P 电脑车 Programmable Bar-Tacker
L 平车(单) Single-Needle Lockstitch
K 拷克车 Overlock
V VC008
C C007
F F007
O 装置类 Attachment

功能 Function
EBJ 自动松紧带搭接机 Automatic Elastic Ring Making Machine
ATS 100 自动三贴条车缝机 Three-Strip Attaching Multi-Needle Sewing Machine
ASM 101 自动罗纹上袖口/裤脚机 Automatic Ribbed Cuff Attaching Machine
ASM 200 自动罗纹下摆机 Automatic Ribbed Hem Attaching To Wide Waistband Machine
TBH 200 自动T恤下摆折缝机 Automatic T-shirt Bottom Hemming Machine
PTA 101 自动上纸标机 Automatic Paper Tag Attaching Machine
STM 100 自动穿绳机 Automatic String Thrusting Machine
ABF 100 自动送扣装置 Automatic Button Feeder

版本
Version

机型编号
Model Number



SIRUBA
Automatic Sewing Machine

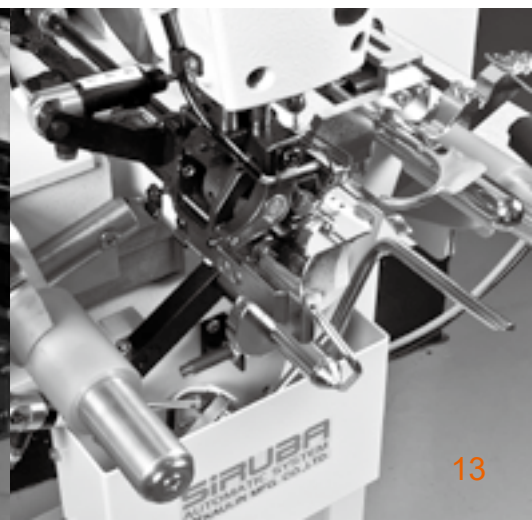
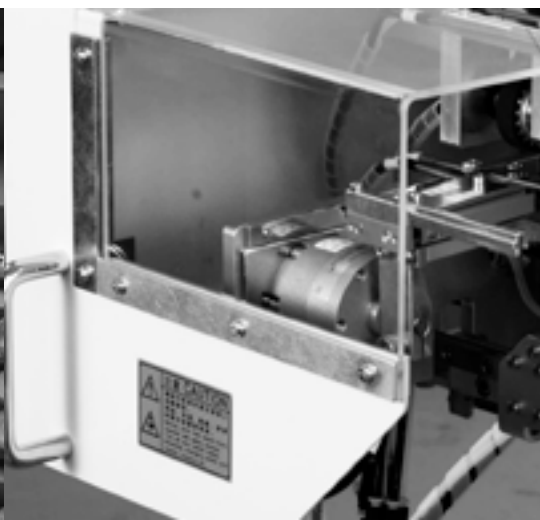

ASP-EBJ SERIES

自动松紧带搭接机 Automatic Elastic Ring Making Machine



ASP-EBJ100A



ASP-EBJ150



ASP-EBJ200

特点

FEATURES

1 EBJ系列实现全自动松紧带车缝。量测、裁剪、送料、车缝一系列连续动作，相对稳定，准确可靠。

EBJ Series realizes automatic sewing of elastic band. Measuring, cutting, feeding, and sewing are in sequence with absolute stability. It is accurate and reliable.

2 无人化生产，成品产量高，投资回收期短，最慢一年即可回收。

Unmanned Production with high yield rate. Payback period is short as maximum 1-year ROI.

3 采用高阶感知器，灵敏侦测入料状况，具有即时警示，自动暂停功能。

By high-end sensors, it detects the feeding sensitively with real-time alarm and auto pause function.

4 可选配整烫装置，确保入料前的平整度，解决皱折或扭曲的问题。

Pre-ironing device is optional, which ensures the flatness when the material is entering, to solve the problem of wrinkles or twists.

5 可选配视觉辨识系统，侦测Logo并依设定位置裁剪与车缝。

Visual identification system is optional, which detects Logo and then positions cutting and sewing according to user's setting.

影片连结
Video link



规格

SPECIFICATIONS

型号 Model	ASP-EBJ100A	ASP-EBJ100S	ASP-EBJ150	ASP-EBJ200
缝纫机机头 Machine Head	JUKI LK-1920		JUKI LK-1920	JUKI AMS210ENSS
车缝速度 Sewing Speed	2500 SPM (最高 Max)			2800 SPM (最高 Max)
使用针型 Needle Type	DP×5 #14			DP×17 #14
线迹形式 Stitch type	单针锁缝 #301 Single Needle Lockstitch #301			
松紧带宽度 Rubber Width	20~50 mm	6~20 mm	20~50 mm	20~90 mm
车缝花型储存 Pattern Memory	EEPROM			IP-420 (JUKI AMS)
最大储存车缝花型数量 Max. Numbers of Pattern	99 种车缝花型 99 Patterns			999 种车缝花型 999 Patterns
切带方式与材料 Tape Cutting Method	刀切 Knife Cutting			◎刀切 Knife Cutting △超声波 Ultrasonic Cutting
生产效率 Production Capacity	视缝制针数而定 举例: 190针缝制样式的情形下, 回圈时间: 8秒/件; 3600件/8小时 Depends on the stitch pattern, Ex: 190 stitches pattern, Cycle Time: 8 Sec./ pcs (Max.); 3600 pcs/ 8Hr	视缝制针数而定 举例: 71针缝制样式的情形下, 回圈时间: 6秒/件; 4800件/8小时 Depends on the stitch pattern, Ex: 71 stitches pattern Cycle Time: 6 Sec./ pcs(Max.); 4800 pcs/ 8Hr	视缝制针数而定 举例: 190针缝制样式的情形下, 回圈时间: 8秒/件; 3600件/8小时 Depends on the stitch pattern Ex: 190 stitches pattern as below Cycle Time: 8 Sec./ pcs(Max.); 3600 pcs/ 8Hr	
缝纫尺寸 Stitch Length				
气体消耗量 Air Consumption	30 公升/分 30 L/Min.			
气压 Air Pressure	0.5 MPa			
电源电压 Power Supply	Single Phase 1Φ AC200~240V 50/60Hz			
电力消耗 Power consumption	750 W (Max)	750 W (Max)	800 W (Max)	800 W (Max)
机器尺寸 Dimensions	(W)1230X(D)1030X(H)1530mm (With table and thread stand 含桌板、线架)			(W)1550X(D)1150X(H)1530mm (With table and thread stand 含桌板、线架)
配件 Device				
收料装置 Stacker	△	△	△	△
热整烫装置 Pre-Ironing	—	—	△	△
LOGO 辨识装置 LOGO Identification	—	—	◎	◎

◎ 标配 Standard

△ 选配 Option

ASV-ATS SERIES

自动三贴条车缝机

Three-Strip Attaching Multi-Needle Sewing Machine



影片连结
Video link

特点

FEATURES

- 1** 特殊设计压脚，快速缝合防止皱折，可依不同特性进行调整(ATS100A/ATS100B)。
Custom-designed presser foot for Adidas 3-stripe sewing. Puckering free and adjustable. (ATS100A/ATS100B)
- 2** 双电眼控制，可减少废料，节省人工裁切收料时间。
Dual-sensor control to reduce material waste and save cutting/collecting time.
- 3** 最短收料长度150mm。
Minimum finished length: 150mm.
- 4** 三颗马达，独立控制送带，张力控制准确。
Stripe feeding controlled by individual motors for a better feeding performance.



规格

SPECIFICATIONS

型号 Model	ASV-ATS100A / ASV-ATS100C / ASV-ATS100B		
是否有特殊压脚 Custom-designed presser foot	ASV-ATS100A: 有 Yes	ASV-ATS100C: 无 No	ASV-ATS100B: 有 Yes
缝纫机机头 Machine Head	SIRUBA VC008-06064P/VPL		
车缝速度 Sewing Speed	2000 SPM (最高Max)		
使用针型 Needle Type	UO × 113GS #11		
车缝平台宽度 Available Width of Stitching Platform	440 mm		
缝纫针距 Stitch Length	6.4 mm		
生产样式 Sewing Pattern	<p style="text-align: center;">可调 (Adjustable)</p>		
气体消耗量 Air Consumption	40公升/分 40 L/min		
气压 Air Pressure	0.5 MPa		
电源电压 Power Supply	Single Phase 1Φ AC200~240V 50/60Hz		
电力消耗 Power Consumption	800 W (Max)		
机器尺寸 Dimensions	(W)1200 × (D)900 × (H)1900 mm (With table and thread stand含桌板、线架)		

※收料限制：布料长度 150 mm 以上

※Material limit : essential requirement cloth length ≥ 150 mm

ASK-ASM101

自动罗纹上袖口/裤脚机 Automatic Ribbed Cuff Attaching Machine

影片连结
Video link



特点

FEATURES

- 1** 自动过骨感知侦测，设定结尾需求针数。
Auto seam detector, easy to set up the stitches after seam.
- 2** 快速调整机构，方便设定与维护。
Quick adjustment mechanism, easy for setting and maintenance.

- 3** 张力调整，自动拉伸，减少布料起皱。
Tension controller for smooth feeding and puckering free.
- 4** 防内卷装置，减少内卷不良率。
Anti-curly edge device reduce sewing defects.

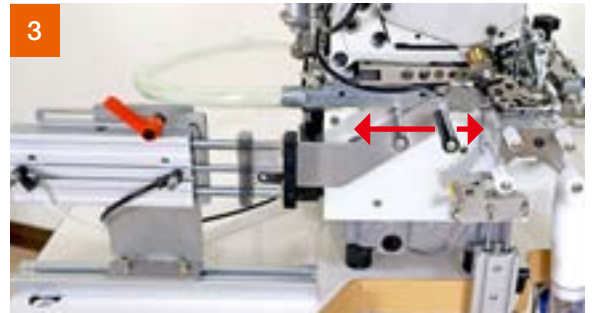

规格

SPECIFICATIONS

型号 Model	ASK-ASM101
缝纫机机头 Machine Head	SiRUBA 747KST-514M-3-24
车缝速度 Sewing Speed	5500 SPM (最高Max)
使用针型 Needle Type	DC × 27 #11
压脚高度 Presser foot Height	8.5 mm (最高Max)
包边宽度 Overedge Width	4 mm
缝纫针距 Stitch Length	2 mm
罗纹布尺寸 (mm) Rib Size (mm)	<div style="text-align: center;"> <p>车缝范围 Sewing Range</p> <p>车缝位置 Sewing Position</p> <p>圆周长 Circumference 225~440mm</p> <p>Height 20~90mm</p> </div> <p>※ 罗纹布口径与布身口径相差需在40mm内，布身布厚>0.9mm，弹性布料。 ※ The difference between the caliber of the ribbed fabric and the fabric body should be within 40mm. The fabric should be elastic and the thickness of fabric body should be greater than 0.9mm.</p>
布厚范围 Fabric Thickness	7mm
气体消耗量 Air Consumption	180公升/分 180 L/min
气压 Air Pressure	0.5 MPa
电源电压 Power Supply	Single Phase 1 Φ AC200~240V 50/60Hz
电力消耗 Power Consumption	500 W (Max)
机器尺寸 Dimensions	(W)825 × (D)640 × (H)1622mm (With table and thread stand 含桌板、线架)
生产效率 Production Capacity	200~240 件/小 (车缝速度:3000 spm 罗纹布尺寸 圆周长:270mm 高度:60mm) 200~240 PCS/Hour (Sewing Speed: 3000 spm, Rib Size: Circumference: 270mm, Height: 60mm)

ASK-ASM200

自动罗纹下摆机 Automatic Ribbed Hem Attaching Machine



特点

FEATURES

1 撑布：可以依照商品需求做尺寸设定。
Fabric tension: Can be adjusted according to product requirements.

2 稳布：搭配Sensor稳布轮可将布边稳定在 $\pm 2\text{mm}$ 内，使其送布量与切布量稳定。
Fabric stability: Using sensor stabilizing wheel can stabilize the cloth edge within $\pm 2\text{mm}$ and make the feeding and cutting stable.

3 骨位侦测：螺纹布骨位自动感测定位功能。
Seam detection: Automatic sensing positioning function for rib fabric seam.

4 叠缝设计：布料骨位感知侦测，简单设定结尾叠缝需求针数。
Overlapping stitching: End overlapping stitching counts can be simply set up by fabric seam detection sensor.

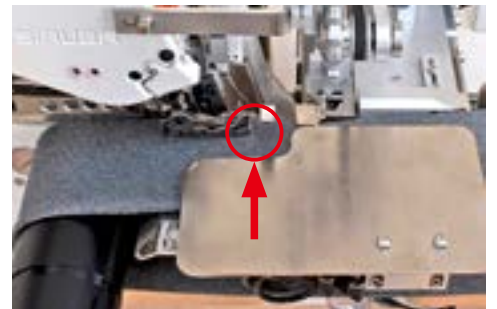

规格

SPECIFICATIONS

型号 Model	ASK-ASM200	
缝纫机机头 Machine Head	SiRUBA 747KST-514M-3-24/VT	
车缝速度 Sewing Speed	4500 SPM (最高Max)	
使用针型 Needle Type	DC × 27 #11	
压脚高度 Presser foot Height	7 mm	
包边宽度 Overedge Width	6 mm	
缝纫针距 Stitch Length	0.5~6 mm	
罗纹布尺寸 (mm) Rib Size (mm)	<p>车缝范围 Sewing Range</p> <p>车缝位置 Sewing Position</p> <p>寬幅 Width 35~55mm</p> <p>圆周长 Circumference 860~1480mm</p> <p>*带口袋之衣款不适用 *Garment with pocket is not applicable</p>	
布厚范围 Fabric Thickness	6.5 mm (Max)	
气体消耗量 Air Consumption	400公升/分 400 L/min	
气压 Air Pressure	0.5 MPa	
电源电压 Power Supply	Single Phase 1 Φ AC200~240V 50/60Hz	
电力消耗 Power Consumption	1K W (Max)	
机器尺寸 Dimensions	(W)1300 × (D)790 × (H)1640 mm (With table and thread stand 含桌板、线架)	
生产效率 Production Capacity	60~80 件/小 (车缝速度:4500 spm 罗纹布尺寸 圆周长:980mm 高度:55mm) 60~80 PCS/Hour (Sewing Speed: 4500 spm, Rib Size: Circumference: 980mm, Height: 55mm)	

ASC-TBH200

自动T恤下摆折缝机 Automatic T-shirt Bottom Hemming Machine

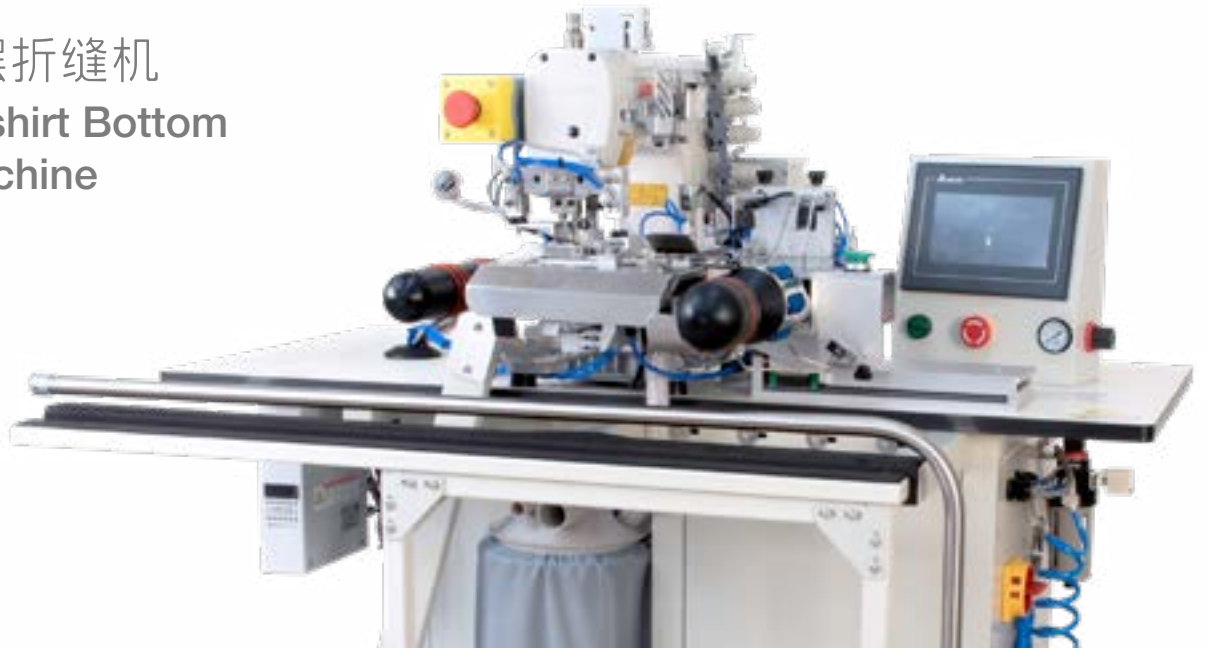

影片连结
Video link



特点





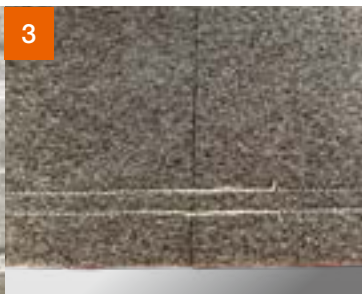

FEATURES

- 1** 专利导向轮模仿人工手势，使布料纠偏功能更强大，面料适用性更宽广。
The patented guide wheel simulates operator's gestures, it makes the machine operating smoothly during sewing, and applicable for more kinds of fabric.
- 2** 专利吹气倒缝功能，真正实现多骨位同方向倒缝。
Patented function of air-blowing reverse stitching makes side seams reverse stitching in the same direction.
- 3** 起缝和结束线迹完全对齐。
The start and end stitches are perfectly aligned.
- 4** 设备自带衣服大小码自动调节功能，避免生产中出现混码而导致缝制错乱。
The equipment comes with an automatic adjustment function of clothes size, which avoids confusion in sewing caused by mixed sizes in production.
- 5** 38-90公分的缝制范围，可以真正的实现XS到5XL自由切换。
The sewing range is 38-90 cm which can sew XS to 5XL.
- 6** 适用于筒状或已包边缝的全自动折下摆车缝。
Fully automatic hemming is suitable for tubular materials or materials with overlock seams.
- 7** 可以做第一或最后工序的操作。
It can be the first stage or last stage of production process.
- 8** 100%棉质纱线的高速车缝。
High-speed sewing with 100% cotton thread.
- 9** 一人可操作多台机器，降低人工缝制难度标准化生产，无需技能工操作。
Machine operators can handle more than one machine simultaneously. Reducing the difficulty of manual sewing and standardizing production, without the need for skilled workers to operate.



规格

SPECIFICATIONS

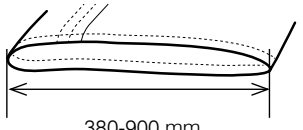
ASC-TBH200	Needle No.	 mm	 mm	mm	 S.P.M. (Max)	 mm	 KG
	UY128		折边宽度 Hem Width 15~30 mm	标配: 5.6 选配: 4.0 / 4.8 / 6.4 Normal standard: 5.6 Optional 4.0 / 4.8 / 6.4	0.3~4.5	4500	L1200 W1200 H1670
生产能力 Capability of Output	80~120 pcs/ hour	适用周长(摊平) Circumference of T-shirt bottom(Flattened)		 380-900 mm 对折中心距 Folding center distance			
电源 Power supply	AC 220V, 50/60Hz						
工作气压 Air Pressure	4 bar						
耗气量 Air Consumption	190 L / min						
缝纫机机头 Machine Head	标配:左切刀筒型绷缝机 / Normal standard: Bottom hemming with left side fabric trimmer C007KP-W812A-356/CRL/UTP						
标配倒骨 Standard seam guide function	要求正、反缝位都可以采用此设备缝制 (带真倒骨功能) It can be used to sew both front and back stitching positions (with true back stitch function)						
IOT物联对接 (选配) IOT interconnection	下单时, 可依需求选择加购 Please select it when ordering						
扫线装置 Sweep the line device	吹气装置 (标配), 电磁铁勾线装置 (选配) Standard configuration: blowing device Optional configuration: Electromagnet wire hooking device						

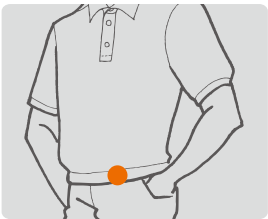

ASP-PTA101

自动上纸标机 Automatic Paper Tag Attaching Machine



特点

FEATURES

- 1** 弹性卡槽，方便调整，最高容量250张(厚度0.5mm)。
Paper card loader is flexible for easy adjustment.
The capacity is up to 250 pieces.
- 2** 旋转缸更平滑与稳定 (ASP-PTA101)。
Smooth and stable rotary cylinder.
- 3** 利用快拆装置，快速调整纸卡尺寸。
Easy to adjust card spec by quick release device.
- 4** 单件车缝的周期时间，约为3-5秒钟。
Cycle time 3-5 sec.
- 5** 储气筒(选配)，解决气源不稳的问题。
Air Tank (Optional), solution to the unstable air supply.



规格

SPECIFICATIONS

型号 Model	ASP-PTA101
缝纫机机头 Machine Head	SIRUBA LKS-1903AN
车缝速度 Sewing Speed	2000 SPM (最高Max)
使用针型 Needle Type	DP×17 #11
纸卡单边长 Card Length	Left 45~65 mm, Right 45~90 mm
纸卡宽度 Card Width	35~65 mm
折痕宽度 Crease Width	5~7 mm
纸卡厚度 Card Thickness	0.4~0.6 mm
车缝范围 Sewing range	<div style="display: flex; justify-content: space-around;"> <div style="text-align: center;"> <p>Singal seam</p> <p>A 3~6mm B 15~30mm</p> </div> <div style="text-align: center;"> <p>Double seam</p> <p>A 3~6mm × 2 B 15~30mm C 20~30mm D ≤ 40mm (考虑缩放比例 Consider scale size)</p> </div> </div>
适用纸卡规格 Card dimensions	
气体消耗量 Air Consumption	40 L/min
气压 Air Pressure	0.5 Mpa
电源电压 Power Supply	Single Phase 1 Φ AC200~240V 50/60Hz
电力消耗 Power Consumption	660 W (Max)
机器尺寸 Dimensions	(W)1050 × (D)705 × (H)1530 mm (With table and thread stand 含桌板、线架)

ASO-STM100

自动穿绳机

Automatic String Thrusting machine



影片连结
Video link



特点

FEATURES

适用于平头锁眼、鸟眼绣孔、金属气眼孔的穿绳工艺

Suitable for flat bottom hole, bird eye embroidery hole, metal air hole string technology.



80~180%
效率分析
Efficiency analysis

Before 20~32s
人工作业劳动强度大，效率低
Manual work quickly tired and low efficiency



After 9~12s
自动化设备作业，低疲劳度、效率高
Automated equipment operation, low fatigue, high efficiency

规格

SPECIFICATIONS

型号 Model	ASO-STM100		
适用孔眼 Applicable hole	切口 incision $\geq 5\text{mm}$ 	直径 diameter $\geq 5\text{mm}$ 	直径 diameter $\geq 5\text{mm}$ 
适用带绳 Suitable for rope	平头眼 Flat button hole 	鸟眼绣 Bird's Eye Embroidery 	金属气眼 Metal eyelet 
噪音 Noise	<79dB		
腰围 Waistline	80-170cm		
电源电压 Power Supply	Single Phase 1 ϕ AC200~240V 50/60Hz		
电力消耗 Power Consumption	700 W (Max)		
重量 Weight	120Kg		
机器尺寸 Machine Dimensions	(W)1180 \times (D)580 \times (H)1750mm (含桌板、线架 With table and thread stand)		

※ 选购配件 Options	钢丝规格 (耗材) Steel wire specification (Consumables)	
 提供童装版元件 (选配) TK01 Provide children's wear edition components (Optional) TK01 适用腰围尺寸 50~90cm 最小裤腰尺寸50cm applicable waist size 50~90cm minimum waist size 50cm	 GS01 标准版弯弯钢丝 (大头) 约7-8mm孔眼 Standard edition bending steel wire (Large head) Coping with 7-8 mm hole.	 GS02 专用版折弯钢丝 (小头) 应对5~6mm孔眼 Special edition bending steel wire (Small head) Coping with 5-6mm hole.

ASO-ABF100

自动送扣装置 Automatic Button Feeder

ASO-ABF100J



ASO-ABF100B



特点

FEATURES

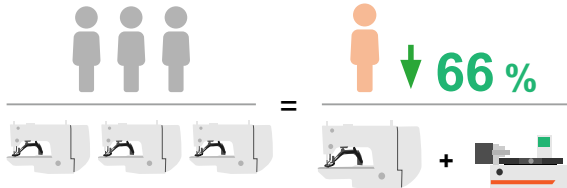

电子钉扣机附自动送扣比传统缝扣机速度提升3倍
Button sewing machine with automatic button feeder enhances 300% efficiency of button sewing.

循环时间: 2.2秒/颗; 13,090颗/ 8小时
Cycle Time: 2.2 Sec./Button; 13,090 Buttons/8 Hr



影片连结
Video link



操作面板

简单图像式操作介面，所有车缝所需资料，皆能清楚显示。

PANEL

User friendly interface, all sewing parameters are clearly shown.



感知器讯号检测

透过操作面板A02功能，检测感知器讯号正常。

SENSOR SIGNAL DETECT

Checking the sensors detecting by A02 function of operation panel.



翻扣机制

自动吹风翻扣功能，提高大尺寸钮扣(ø16mm以上)的准确性。

FLIP MECHANISM

Flip mechanism enhance the accuracy of ø16mm up button by auto air-blow.



钮扣夹爪自动感知器

可钮扣夹爪侦测钮扣位置，避免空缝。

SMART SENSOR OF BUTTON CLAMP

Button clamp can detect the button position and avoid sewing without button.



送扣轨道调整

送扣轨道调整由步进马达准确控制。

BUTTON CHANNEL ADJUSTMENT

Channel adjustment is controlled by stepping motor accurately.



单键退扣

按键即可清空轨道内钮扣。

DISCHARGING

Press the key and then remove all the buttons in the channel.



电子式自动量测钮扣

准确、极速，短时间内即可完成更换钮扣设定。

ELECTRONIC AUTOMATIC MEASUREMENT OF BUTTON SIZE

Accurate, Ultrafast, adjusting different button in a short time.

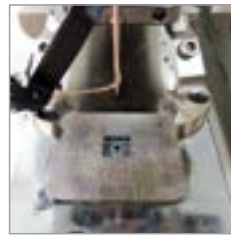

机头上钮扣夹爪

变换钮扣尺寸时，钮扣夹爪无须变更调整。

BUTTON CLAMP OF MACHINE HEAD

Button clamp is suitable for variety button size, the clamp can be used in different button size and no further adjustment needed.



送扣载具模组化

可因应不同钮扣规格，快速更换适合的送扣载具。

BUTTON CARRIER MODULE

Modularized button carrier is for different button size and replacement.



ABF-J(B)安装

简易、快速安装

INSTALLATION

Easy and friendly installation.

规格

SPECIFICATIONS

型号 Model	ABF100J	ABF100B
适用车头 Apply For	Juki LK-1903A/ LK-1903AN Juki LK-1903B/ LK-1903BN	Brother 438FX
工作夹具提升量 Rising Amount of Clamp	最大:13mm Maximum:13mm	
喂扣时间 Feeding Time	0.35~0.5秒 0.35~0.5 Sec.	
使用钮扣 Button	种类：圆形平扣 尺寸:Φ8~26mm ※Ø10mm以下为特规，须更换规格件 Type: Circle Flat Button Size: Φ8~26mm ※Ø10mm is special specification, need to replace standard parts.	
使用扣孔 Button Hole	标准: 2或4孔 选配: 3孔 Standard: 2&4 Holes Option: 3 Holes	
钮扣厚度 Thickness of Button	1.5~3.5mm	
气体消耗量 Air Consumption	20公升/分 20 L/min	
气压 Air Pressure	0.5 MPa	
电源电压 Power Supply	单相AC 200~240V 50/60Hz single-phase AC 200~240V 50/60Hz	
机器尺寸 Dimensions	宽 440 × 深 560 × 高 280mm 440(W)x560(D)x280(H)mm	

Remark:

标配：专用桌板、脚架、钮扣压脚、底板、大小锯齿板及12组标准送扣载具使用
选配：3孔扣孔、对位器、雷射灯对位器

*钮扣尺寸定义：

超小钮扣尺寸Φ8~10mm，小钮扣尺寸Φ10~20mm，大钮扣尺寸Φ20~26mm
钮扣夹爪适用范围Φ8~26mm，但缝制超小或大钮扣时，需视钮扣厚度与凸面的情况

**大小锯齿板选用建议

使用钮扣	尺寸:Φ8~16mm	尺寸:Φ16~25mm
	小钮扣锯齿板	大钮扣锯齿板

Remark:

Standard: Professional table, All Set of Button Presser Foot, Small/Big Button
Serrated Plate and Bottom Plate, 12 Sets of Standard Button Carrier.
Option: 3-Holed of Button Carrier, Button Spacer, Button Spacer with Laser Light.

*The definition of Button Size:

Extra small button size is Φ8~10mm, small button size is Φ10~20mm, and large button size is Φ20~26mm. Basically, Button clamp of machine head is applied for Φ8~26mm, but that sewing extra/ large button size are depend on its thickness and convexity.

**Suggestion of selecting the serrated plate

Button	Size: Φ8~16mm	Size: Φ16~25mm
		The small serrated plate

送载具模组规格

Button Carrier Specification

零件编码 Code of Parts	X +0.05 -0.05	D +0.05 -0.05	钮扣孔数 Button Holes
ABF118	2.2	1.0	4
ABF119	2.2	1.0	2
ABF120	2.4	1.2	4
ABF121	2.4	1.2	2
ABF269	2.6	1.2	4
ABF270	2.6	1.2	2
ABF122	2.8	1.2	4
ABF123	2.8	1.2	2
ABF124	3.2	1.2	4
ABF125	3.2	1.2	2
ABF126	3.6	1.2	4
ABF127	3.6	1.2	2

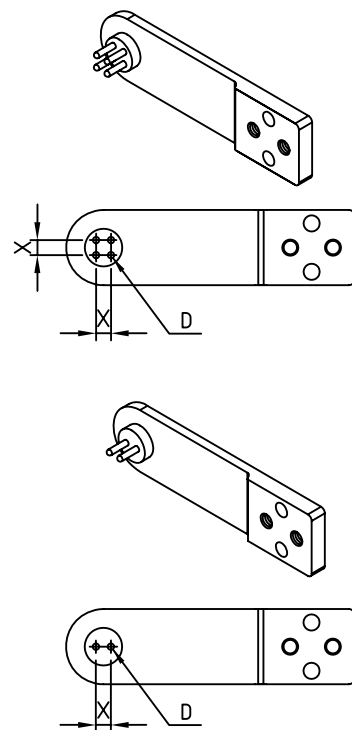

钮扣形状

Button Shape

适用钮扣的形状 Available Shape of Button	不适用钮扣的形状 Unavailable Shape of Button
<p>钮扣的两面需有明显的不同，用以区别正反面。 (凹面和凸面须有至少1.2mm以上的差距。)</p> <p>The two sides of the button must be clearly different to distinguish the front and back (There must be a gap of more than 1.2mm between the concave surface and the convex surface)</p>	<p>两面皆相同之钮扣，机器无法判别</p> <p>Machine can't work if one side of the button is identical to the other.</p>



OVERLOCK SEWING MACHINE

700LQ 700L

747 L - 514 M - 2 - 2 4 / VT

①线数
Thread Numbers

737	: 3T
747	: 4T
757	: 5T
767	: 6T

⑥针距
Needle Gauge

⑦包边宽度
Overedge Width

⑧配件
Device

②机种别
Model

LQ	机电一体 Mechatronic
L	基本型 Basic Type

③缝合方式
Sewing Types

503	
504	
505	
512	
514	
516	
644 (514+401)	

④车缝布料/上勾针缝容量
Sewing Fabric/Upper Looper Capacity

F	轻薄布料 Fine Weight Fabric
L	薄布料 Light Weight Fabric
M	中厚布料 Medium Weight Fabric
H	厚布料 Heavy Weight Fabric
X	特厚布料 Extra Heavy Weight Fabric

⑤送具型式
Feed Dog Type

2	2排 (标准) 2 Row (Standard)
3	3排 (标准) 3 Row (Standard)
4	4排 (标准) 4 Row (Standard)
6	1排 (特殊) 1 Row (Special)
7	2排 (特殊) 2 Row (Special)
8	3排 (特殊) 3 Row (Special)

OVERLOCK DD SERVO MOTOR

747L-514M-3-24 / ECA / DKL□□

⑨DKL□□ 700L型直驱电控组
Direct Drive Servo Motor for 700L
请参阅P.39-40 Detail on Page.39-40

700LQ SERIES FEATURES

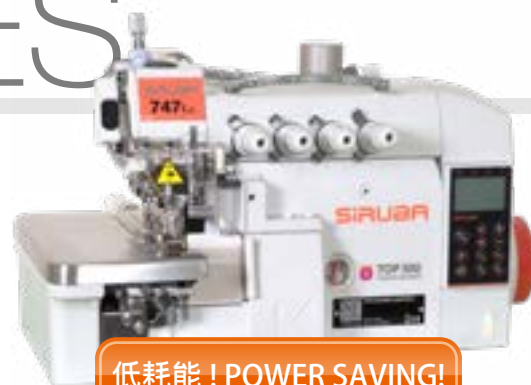

低耗能! POWER SAVING!

机电一体超高速包缝机

Mechatronic High Speed Overlock Sewing Machine

将高速直驱伺服马达、电控箱、电源开关完全整合于缝纫机中，并支持多种选配功能，实现一体直驱化的包缝机。

700LQ is equipped with high-speed direct drive servo motor, electric control box, and power switch. In addition, it supports a variety of optional functions to become an all-in-one direct drive overlock sewing machine.

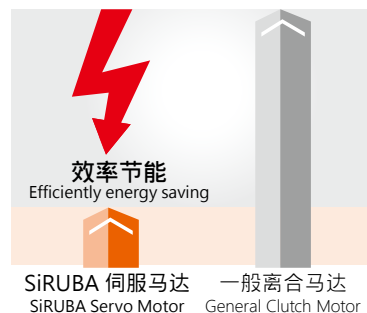

布盖板安全感测装置
Cloth cover safety sensor



抬压脚安全感测装置
Presser Foot Lift Sensor



切刀安全感测装置
Cutter Sensor

1 智能化安全感测装置

Intelligent Safety Sensor.

2 全新触碰式按键与液晶显示面板

Touch buttons and LCD display panel.

3 多国语言操作介面

Operation interface in multiple languages.

4 高速稳定的伺服马达运转更平稳

High speed stable servo motor to ensure the stability of operation.

5 多功能一体机型更节能、性能更好

It supports a variety of optional functions with mechatronic design, energy-efficient and performs well.

6 微油润滑技术提供干净清爽的缝制体验

Micro-oil lubrication technology keeps sewing process clean from oil pollution.



规格

SPECIFICATIONS

747LQ - 514 M - 3 - 2 4 / ECA-U

① 线数 Thread numbers

② 机种别 Model

③ 缝合方式 Sewing types

④ 车缝布料/上勾针缝容量
Sewing fabric/Upper looper capacity

⑤ 送具型式 Feed dog type

⑥ 针距 Needle gauge

⑦ 包边宽度 Overedge width

⑧ 配件 Device

700LQ	布料厚度 Fabric Weight			①	⑥	⑦	④	⑤	⑥	⑦	⑧	配件 Device	
	L	M	H										
737LQ-504M-3-04				1	2	-	4	0.7~2	3.6	6	#11	7000	ECA-U, ECB-U
747LQ-514M-3-24				2	4	2	4	0.7~2	3.6	5.5	#11	7000	ECA-U, ECB-U, VTE-U
757LQ-516M-3-35				2	5	3	5	0.7~2	3.6	5.5	#14	7000	ECA-U, ECB-U, CTE-U
767LQ-644M-3-324				3	6	3+2	4	0.7~2	3.6	5	#11	7000	

NOTE: For more information regarding the specification, please visit our website www.siruba.com

配件 DEVICE

ECA-U

气动式切刀

PNEUMATIC TYPE TAPE/THREAD CUTTER



自动切刀装置

电眼侦测到布料前后边缘时，切刀会准确下刀，自动切断空车线。搭配吸风线槽，操作更顺畅。

Automatic thread cutter device
When sensor detects the front and rear edges of the fabric, the cutter automatically will cut the thread. Compatible with air suction slot, which makes the operation more smoothly.



可调式电眼装置

针对网纱、强反光丝光棉等特殊面料，采用专业的电控程式控制，均能轻松车缝及完成切线，不会造成切刀误切。

Adjustable sensor device
For special fabrics such as mesh yarn and strong reflective mercerized cotton, professional electric control program is adopted, which can easily sew and complete thread trimming without causing cutting mistake.

ECB-U

电动式切刀

SOLENOID TYPE TAPE/THREAD CUTTER



手动切刀按键

如因操作问题没有切断线，可由此按键进行手动切线。

Manual trimming button
If the thread was not cut due to the operation, it can be done by using manual cutter button.



自动抬压脚装置

脚踏板回踏，抬升压脚，操作快速方便，减少不必要的体力消耗，制程速度产量加倍。

Automatic presser foot lifter
Pressing the foot pedal backward to lift the presser foot, enabling quick and convenient operation, doubling the production speed and output.

VTE-U

侧吸式自动切线装置

SIDE SUCTION AUTO THREAD CHAIN CUTTER DEVICE

电控系统支持电眼节能装置，采用电眼侦测布边，利用控制箱调整旋钮，控制吸风功能在切线时运作，减少空压设备的能源消耗，并避免缝线浪费。

Computerized system drives sensor-controlled energy saving device. Sensor checks the fabric edge. Turn the button of control box to set the time of air suction of chain-cutter. It saves the energy consuming of air compressor system and also saves thread consuming.

CTE-U

下吸式自动切线装置

FLAT SUCTION AUTO THREAD CHAIN CUTTER DEVICE



VTE-U



CTE-U

(附电眼节能装置)
(WITH SENSOR-CONTROLLED ENERGY-SAVING DEVICE)

卓越性能 来自不断的淬炼

Excellent performance comes from
constant refinement

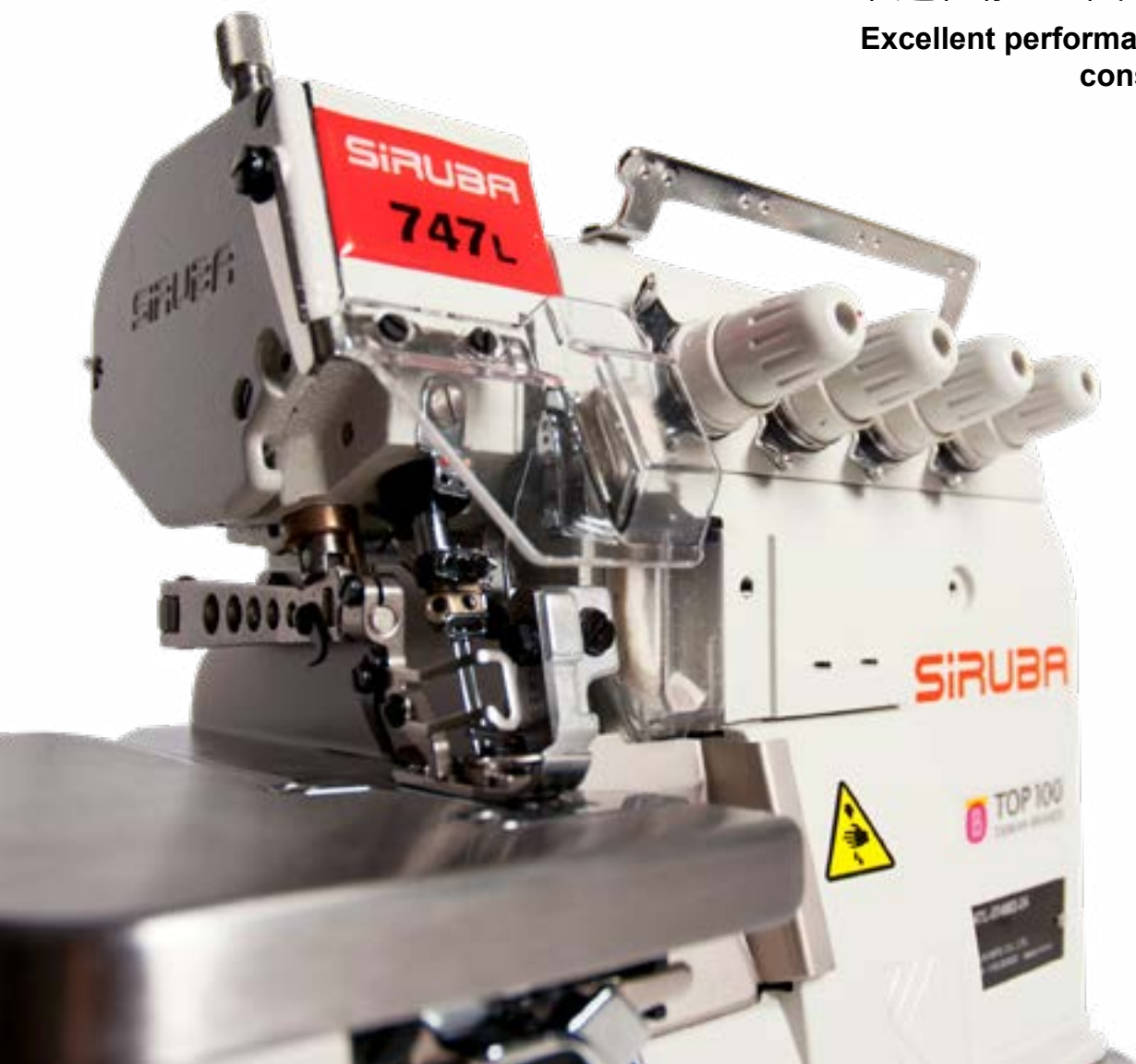

700L

超高速安全包缝机

Ultra High Speed Safety Overlock Sewing Machine



700L



700L series

在 SiRUBA 包缝机技术的既有基础上，大幅度提升性能

追求控线与送布的根本性能，实现较好的缝纫品质

过线系统全面优化，在每一个细节都考虑了线的张力状态，实现了极佳的控线能力。送具、压具与切布刀的综合调校，优化送布性能。在面料的厚薄适用性，700L在规格上有更全面的应对，实现了令人满意的车缝品质。

In pursuit of the core performance of thread controlling and fabric feeding, it realizes perfect sewing quality.

Threading system is fully optimized. As we fine-tuned every detail about the thread tension, it realizes a very good thread controlling. The feed dog, presser foot, and fabric trimmer are well coherent to make the fabric feeding optimized. Regarding the applicability range of fabric weight, 700L has a more comprehensive correspondence by specification, and realizes the satisfactory seam quality.

追求机械的准确度，实现高速运转下的稳定性

提升零件的制造工艺，在精度、表面处理、内孔精加工和零件的轻量化设计，每一个细节都严谨的配合，实现了高速、稳定、低噪音与低振动的机械性能。

In pursuit of mechanical precision, it realizes the stability under high speed operation.

Improving the spare parts manufacturing process, the spare parts manufacturing process is improved. As the precision, surface treatment, micro-finish honing and parts light weight design are strictly coordinated in details, it realizes the high speed, stable, low noise and vibration mechanical performance.

车缝应用的范围更宽

针对车缝面料的厚度，在规格上(包括规格组、上勾针行程、机构时位…等)有更全面的对应，超薄或超厚的面料都有令人满意的车缝品质。

The wider range of sewing application

Regarding sewing material thickness, we have a full specification (including gauge set, upper looper stroke, mechanical timing... etc) to satisfy customer requirement. We provide the nice seam quality in sewing fine or extra heavy material.

700L	布料厚度 Fabric Weight	①			⑥	⑦	⑧	⑨	⑩	⑪	⑫	⑬	
		L	M	H	mm	mm	mm	mm	mm	mm	DCX27	S.P.M. (Max)	
一般包缝 General Seaming	737L-503M-3-04				1	3	-	4	0.7~2	3.6	6	#11	7500
	737L-504F-2-04				1	3	-	4	0.7~2	3.6	5	#11	7500
	737L-504M-3-0 ⑦				1	3	-	4,5	0.7~2	3.6	6	#11	7500
	747L-512M-3-25				2	4	2	5	0.7~2	3.6	5.5	#11	7500
	747L-512M-3-34				2	4	3	4	0.7~2	3.6	5.5	#11	7500
	747L-514M-3-2 ⑦				2	4	2	3,4,5	0.7~2	3.6	5.5	#11	7500
	747L-514H-3-28				2	4	2	8	0.7~2	3.6	7	#11	6500
	757L-516L-2-24				2	5	2	4	0.7~2	3.6	5.5	#14	7500
	757L-516L-2-35				2	5	3	5	0.7~2	3.6	5.5	#14	7500
	757L-516M-3-35				2	5	3	5	0.7~2	3.6	5.5	#14	7500
	757L-516M-3-55				2	5	5	5	0.7~2	3.6	5.5	#14	7500
	767L-644M-3-324				3	6	3+2	4	0.7~2	3.6	5	#11	7000
	767L-644M-3-524				3	6	5+2	4	0.7~2	3.6	5	#11	7000
细包缝 Fine Edging	737L-504F-2-02/GAL				1	3	-	2	0.7~2	3.6	5	#9	7500
	737L-504F-2-15				1	3	-	1.5	0.7~2	3.6	5	#9	7500
	737L-504M-2-15				1	3	-	1.5	0.7~2	3.6	6	#9	7500
肩带包缝 Tape Inserting	747L-514M-3-2 ⑦ /TG				2	4	2	4,5	0.7~2	3.6	5.5	#11	7500
拷下摆 Blind Hemming	737L-505F-2-04				1	3	-	4	0.7~2	3.6	5	#9	7500
鱼骨缝 Fishbone Stitch	747L-503M-2-23				1,2	2,3	-	3	0.7~2	-	6	#11	6500
折景车缝 Gathering	747L-514M-8-24/GA				2	4	2	4	0.7~2	3.6	5.5	#11	7000
	757L-516M-8-35/GA				2	5	3	5	0.7~2	3.6	5.5	#14	7000
	757L-516M-8-55/GA				2	5	5	5	0.7~2	3.6	5.5	#14	7000
松紧带车缝 Elastic Attaching	737L-504M-3-04/LFC-3				1	3	-	4	0.7~2	3.6	6	#11	4500
	737L/WR/LFC-3				1	3	-	-	-	-	-	#11	4500
	747L-514M-3-2 ⑦ /LFC-3				2	4	2	4,5	0.7~2	3.6	5.5	#11	4500
手动线头包缝 Manual Back Latching Seaming	737L-504M-7-04/BK				1	3	-	4	0.7~2	3.6	6	#11	7500
	747L-514M-7-2 ⑦ /BK				2	4	2	3,4	0.7~2	3.6	5.5	#11	7500
	747L-514H-7-2 ⑦ /BK				2	4	2	4,5	0.7~2	3.6	7	#16	6500
全自动手动线头包缝 Fully Auto Back Latching Seaming	737L-504M-3-0 ⑦ /BKF1				1	3	-	4	0.7~2	3.6	6	#11	6500
	747L-514M-3-2 ⑦ /BKF1				2	4	2	4	0.7~2	3.6	5.5	#11	6500
厚毛衣料包缝 Over Seaming On Bulky Knitwear	747L-514H-4-24				2	4	2	4	0.7~2	3.6	7	#16	6500
	747L-514H-4-25				2	4	2	5	0.7~2	3.6	7	#16	6500

※ 搭配厚料修布角刀

With heavy material angle knife.

700L		布料厚度 Fabric Weight			①	⑥	⑦	⑧	⑨	⑩	⑪	⑫	⑬
		L	M	H									
牛仔安全缝 Jeans Safety Stitch	757L-516H-3-5 ⑦				2	5	5	5,6	0.7~2	3.6	7	#16	6000
	757L-516X-3-5 ⑦ ※				2	5	5	5,6	0.7~2	3.6	7	#16	6000
厚毛衣料肩带包缝 Tape Inserting On Bulky Knitwear	747L-514H-4-24/TG				2	4	2	4	0.7~2	3.6	7	#16	6500
	747L-514H-4-25/TG				2	4	2	5	0.7~2	3.6	7	#16	6500
口袋边包缝 Pocket Binding	757L-516M-3-35/PS				2	5	3	5	0.7~2	3.6	5	#14	7000
	757L-516M-3-55/PS				2	5	5	5	0.7~2	3.6	5	#14	7000
	757L-401M-8-⑥ 0/TA				2	4	3,5	-	0.7~2	3.6	5	#14	7000
气动式切刀 Pneumatic Type Tape/Thread Cutter	737L-504M-3-04/ECA(-U)				1	3	-	4	0.7~2	3.6	6	#11	7000
	747L-514M-3-24/ECA(-U)				2	4	2	4	0.7~2	3.6	5.5	#11	7000
	747L-514M-3-24/ECA/BKT				2	4	2	4	0.7~2	3.6	5.5	#11	7000
	747L-514H-3-28/ECA(-U)				2	4	2	8	0.7~2	3.6	7	#11	6500
	747L-514H-4-25/ECA-U				2	4	2	5	0.7~2	3.6	7	#16	6500
	757L-516M-3-⑥ 5/ECA(-U)				2	5	3,5	5	0.7~2	3.6	5.5	#14	7000
	757L-516H-3-55/ECA-U				2	5	5	5	0.7~2	3.6	7	#16	6500
	757L-516X-3-56/ECA-U				2	5	5	6	0.7~2	3.6	7	#16	6000
	767L-644M-3-324/ECA-U				3	6	3+2	4	0.7~2	3.6	5	#11	7000
电动式切刀 Solenoid Type Tape/ Thread Cutter	737L-504M-3-04/ECB(-U)				1	3	-	4	0.7~2	3.6	6	#11	7000
	747L-514M-3-2 ⑦ /ECB(-U)				2	4	2	3,4	0.7~2	3.6	5.5	#11	7000
	747L-514H-3-28/ECB				2	4	2	8	0.7~2	3.6	7	#11	6500
	747L-514M-3-23/ECB-U				2	4	2	3	0.7~2	3.6	5.5	#11	7000
	747L-514H-4-25/ECB-U				2	4	2	5	0.7~2	3.6	7	#16	6500
	757L-516M-3-⑥ 5/ECB(-U)				2	5	3,5	5	0.7~2	3.6	5.5	#14	7000
	757L-516X-3-56/ECB-U				2	5	5	6	0.7~2	3.6	7	#16	6000
	767L-644M-3-324/ECB(-U)				3	6	3+2	4	0.7~2	3.6	5	#11	7000
	767L-644M-3-524/ECB-U				3	6	5+2	4	0.7~2	3.6	5	#11	7000

700L		布料厚度 Fabric Weight			①	⑥	⑦	⑧	⑨	⑩	⑪	⑫	⑬
		L	M	H									
侧吸式自动切线装置 (附电眼节能装置) Side Suction Auto Thread Chain Cutter Device (with Sensor-Controlled Energy-Saving Device)	737L-504M-3-04/VTE(-U)				1	3	-	4	0.7~2	3.6	6	#11	7000
	737L-504F-2-15/ VTE				1	3	-	1.5	0.7~2	3.6	6	#9	7000
	747L-514M-3-24/ VTE(-U)				2	4	2	4	0.7~2	3.6	5.5	#11	7000
	747L-514H-3-28/ VTE				2	4	2	8	0.7~2	3.6	4	#11	6500
	747L-514M-3-24/ VTA				2	4	2	4	0.7~2	3.6	5.5	#11	7000
下吸式自动切线装置 (附电眼节能装置) Flat Suction Auto Thread Chain Cutter Device(with Sensor- Controlled Energy- Saving Device)	747L-514M-3-24/ CTE(-U)				2	4	2	4	0.7~2	3.6	5.5	#11	7000
	757L-516L-2-24/ CTE(-U)				2	5	2	4	0.7~2	3.6	5.5	#14	7000
	757L-516M-3-35/ CTE(-U)				2	5	3	5	0.7~2	3.6	5.5	#14	7000
	757L-516M-3-55/ CTE(-U)				2	5	5	5	0.7~2	3.6	5.5	#14	7000
	757L-516X-3-56/ CTE(-U) ※				2	5	5	6	0.7~2	3.6	7	#16	6000
下吸式切线装置 Flat Suction Thread Chain Cutter Device	767L-644M-3-324/CT				3	6	3+2	4	0.7~2	3.6	5	#11	7000
	767L-644M-3-524/CT				3	6	5+2	4	0.7~2	3.6	5	#11	7000
电动式切布条/ 松紧带条装置 Electric Type Tape / Elastic Trimmer	747L-514M-3-24/ EC				2	4	2	4	0.7~2	3.6	5.5	#11	6500
上下层防卷边 Top and Bottom Anti-Curly Material	747L-514M-3-24/VT/UC				2	4	2	4	0.7~2	3.6	5.5	#11	7000

※ 搭配厚料修布角刀
With heavy material angle knife.

规格索引, 详细请参考P.31 Specification index, please refer to P.31

- | | | | |
|---------------------|---|-----------------------|--|
| ① 线数 Thread numbers | ④ 车缝布料/上勾针缝容量
Sewing fabric/Upper looper
capacity | ⑥ 针距 Needle gauge | ⑨ 马达 Motor
U: U Series
H: H Series |
| ② 机种别 Model | ⑤ 送具型式 Feed dog type | ⑦ 包边宽度 Overedge width | ⑧ 配件 Device |

700L直驱系列

700L DD Motor Series

承续 700QD 系列的丰富实战经验，SiRUBA 电控技术再提升
Based on the rich experience of 700QD Series, SiRUBA upgrades the control technology.



采用高速伺服马达

- 以充沛的动力，实现7500 RPM的运转速度
- 制造精度高，噪音小，发热低

The high speed servo motor

- By the plenty power, it realizes the operation speed of 7500 RPM.
- High precision makes low noise level and low heat.

采用新型电眼，更灵敏，更准确，侦测无死角

- 体积小，安装于车布板下方，单一方向侦测布边
- 不需调整电眼位置，适用于各种车缝作业情形
- 克服因棉絮阻挡而造成感测失灵的问题

The new sensor is more sensitive, more accurate, no blind spot.

- It is very small, installed under the sewing bed, detecting the fabric by single direction.
- No need to adjust the position, apply to a variety of sewing operations.
- Overcoming the problem of sensory failure due to dust blocking.

控制器模组化设计，以多种组合，全方位满足各种需求

- 经济型：节能省电，并可驱动EC切布条装置
- 多功能型：标配电眼，侦测布料边缘，以进行自动模式车缝，并可切换半自动或手动模式
- 多功能型分为气动型与电动型，依客户的厂房设备，选择适合的规格

The controller modularized design, with a variety of combinations, comprehensively meets the various demands.

- Economic type: Energy saving, and also drives EC device, electrical tape trimmer.
- Multi-function type: the sensor checks fabric edge for automatic sewing mode. Also semi-auto or manual mode can be switched on demand.
- Multi-function type includes pneumatic and electrical type. Customers may choose the suitable specification according to the factory facility.

700L 产品组合：配件与直驱电控组

Product Package: Devices and Direct Drive Control Sets

直驱电控组 Direct Drive Control Set	配件 Device	功能 Function	配件表 Accessory List														
			电眼 Sensor	安全 开关 Safety Switch	操作 面板 Control Panel	手动 开关 Manual Cut Switch	松线 Thread Release	切布条 Tape Cutter	吸风切线 Suction Trimmer		LED 照明 LED Light	立式 踏板 Standing Operation Padel	抬压脚 Auto Foot Lifter	吸风组 Suction Set	针板 Needle Plate		
DKLH -0 经济型 Economic Type		一般车缝 General Sewing															
	VT	吸风切线 Suction Thread Chain Cutter										●				#4	#3 #4
	CT	吸风切线 Suction Thread Chain Cutter											●			#4	#3 #4
	EC	电动切布条 Electric Type Tape Trimmer				●				●			●				

直驱电控组 Direct Drive Control Set	配件 Device	功能 Function	配件表 Accessory List												
			电眼 Sensor	安全 开关 Safety Switch	操作 面板 Control Panel	手动 开关 Manual Cut Switch	松线 Thread Release	切布条 Tape Cutter	吸风切线 Suction Trimmer		LED 照明 LED Light	立式 踏板 Standing Operation Padel	抬压脚 Auto Foot Lifter	吸风组 Suction Set	针板 Needle Plate
									侧切 Side Cutter	平切 Flat Cutter					
DKLH□-1 多功能 气动型 Multi-function Pneumatic Type	ECA	气动切布条 Air Type Tape Trimmer	●	●	●	●		●			●	#2	●	●	标准型 Standard
	VTE	吸风切线 Suction Thread Chain Cutter	●	●	●		#1		●		●	#2	●	●	
	VTA	吸风切线 Suction Thread Chain Cutter	●	●	●		#1		●		●	#2	●	●	
	CTE	吸风切线 Suction Thread Chain Cutter	●	●	●		#1			●	●	#2	●	●	
	UC	上下层防卷边 Top and Bottom Anti-Curly Edge		●	●				●		●	#2	●	●	
	BKT	简易型自动包线头 Simplified Auto Back Latch	●	●	●	●	●	●			●	#2	●	●	
DKLH□-2 多功能电动型 Multi-function Electric Type	ECB	电动切布条 Electric Type Tape Trimmer	●	●	●	●			● Solenoid Type			●	#2	● Solenoid Type	●
DKLU□-0 经济型 Economic Type		一般车缝 General Sewing									●				
DKLU□-1 多功能型 Multi-function Type	ECA-U	气动切布条 Air Type Tape Trimmer	●	●	●	●		●			●	#2	●	●	加长型 Long type
	ECB-U	电动切布条 Electric Type Tape Trimmer	●	●	●	●		●			●	#2	● Solenoid Type	●	
	VTE-U	吸风切线 Suction Thread Chain Cutter	●	●	●	●	●		●		●	#2	●	●	
	CTE-U	吸风切线 Suction Thread Chain Cutter	●	●	●	●				●	●	#2	●	●	

备注 Remark :

● 标准配备 Standard accessory : 吸风组为 700L 电眼型的标准配备 The suction set is standard accessory of 700L sensor type models.

选配 Optional accessory :

#1: BK321-4 | #2: EC467-A | #3: ①TUA-31 需有空压设备 ②TUD-2 无电刷马达驱动 | #4: TUA-32K 需有空压设备

#1: BK321-4 | #2: EC467-A | #3: ①TUA-31 Air compressor is required. ②TUD-2 Driven by Brushless motor. | #4: TUA-32K Air compressor is required.

TUA-3X

三合一吸风集尘组
3-IN-1 SUCTION DEVICE  Device

代号 Code	功能组件 Functional Section			搭配 配件 Collocated Device	适用机型 Applicable Model
	三吸组 3-In-1 Suction Set	气动抬压脚 Pneumatic Presser Foot Lifter	机械阀 Mechanical Type Air Switch		
TUA-31	V	/	单联 Single way	VT CT	700L
TUA-32K			V		



规格

SPECIFICATIONS

737L - 504 F - 2 - 0 4 / DKLU

规格索引, 详细请参考P.31 Specification index, please refer to P.31

- ① 线数 Thread numbers
- ② 机种别 Model
- ③ 缝合方式 Sewing types
- ④ 车缝布料/上勾针缝容量 Sewing fabric/Upper looper capacity
- ⑤ 送具型式 Feed dog type
- ⑥ 针距 Needle gauge
- ⑦ 包边宽度 Overedge width
- ⑧ 配件 Device
- ⑨ 马达 Motor
U: U Series
H: H Series

L1 Device							Remark			
737L-503M-3-04	1	3	-	4	0.7~2	3.6	6	—	7500	A
737L-504F-2-04/(⑨)	1	3	-	4	0.7~2	3.6	5	H / U	7500	
737L-504M-3-0⑦/(⑨)	1	3	-	4,5	0.7~2	3.6	6	H / U	7500	B
747L-512M-3-25/(⑨)	2	4	2	5	0.7~2	3.6	5.5	H / U	7500	D
747L-512M-3-34/(⑨)	2	4	3	4	0.7~2	3.6	5.5	H / U	7500	D
747L-514M-3-2⑦/(⑨)	2	4	2	3,4,5	0.7~2	3.6	5.5	H / U	7500	C
747L-514H-3-28/(⑨)	2	4	2	8	0.7~2	3.6	7	H / U	6500	
757L-516L-2-24/(⑨)	2	5	2	4	0.7~2	3.6	5.5	H / U	7500	
757L-516L-2-35/(⑨)	2	5	3	5	0.7~2	3.6	5.5	H / U	7500	
757L-516M-3-35/(⑨)	2	5	3	5	0.7~2	3.6	5.5	H / U	7500	
757L-516M-3-55/(⑨)	2	5	5	5	0.7~2	3.6	5.5	H / U	7500	
767L-644M-3-324/(⑨)	3	6	3+2	4	0.7~2	3.6	5	H / U	7000	E
767L-644M-3-524/(⑨)	3	6	5+2	4	0.7~2	3.6	5	H / U	7000	E

一般包缝

适用于特薄至中厚布料的包缝

Remark

- A: 上勾针为盲勾针
- B: 单排送具
- C: 适用于薄至中厚布料的包缝
- D: 用于薄至中厚布料的一般缝合 (假五线)
- E: 适用于薄至中厚布料的一般缝合, 适合小量生产的打样室或工作室选用, 可由勾针及针的变换车缝出5种不同的缝合方式 (504,514,516, 401, 644)

GENERAL SEAMING

For regular seaming on light to medium fabric.

- A: Upper looper is blind looper
- B: Single row feed dog
- C: For regular seaming on light to medium fabric.
- D: Mock 516 seaming
For regular seaming on light to medium fabric.
- E: For regular seaming on light to medium fabric.
Specially suitable for small production workshop, and fashion design studio. A variety of five different sewing types by changing number of needle and looper. (504, 514, 516, 401, 644).



504



514



512



516



644(401+514)

选购配件 OPTIONAL DEVICE
VT, TUA

规格 SPECIFICATIONS 737L-504F-2-02/GAL/DKLU

规格索引, 详细请参考P.31 Specification index, please refer to P.31

- ① 线数 Thread numbers ④ 车缝布料/上勾针缝容量 Sewing fabric/Upper looper capacity ⑥ 针距 Needle gauge ⑨ 马达 Motor
 U: U Series
 H: H Series
- ② 机种别 Model ⑦ 包边宽度 Overedge width
- ③ 缝合方式 Sewing types ⑧ 配件 Device

L2 Device

										Remark
737L-504F-2-02/GAL/(⑨)	1	3	-	2	0.7~2	3.6	5	H / U	7500	A
737L-504F-2-15/(⑨)	1	3	-	1.5	0.7~2	3.6	5	H / U	7500	B
737L-504M-2-15/(⑨)	1	3	-	1.5	0.7~2	3.6	6	H / U	7500	C

细包缝 FINE EDGING



737L-504F-2-02/GAL

- A. 适用于特薄布料的卷边细包缝 (荷叶边) 例如: 手帕、礼服等
- B. 适用于特薄布料的卷边细包缝 (手帕边包缝) 例如: 丝绸类布料的手帕、礼服等
- C. 适用于薄至中厚布料的细包缝 (手帕边包缝) 例如: 手帕、礼服等

- A. For fine edging on extra light knit fabric. The presser foot is with fine folding function. (falbala edging)
 Eg : Handkerchief & dress...etc.
- B. For fine edging on extra light knit fabric. The presser foot is with fine folding function. (handkerchief edging)
 Eg : Handkerchief & dress of silk fabric...etc.
- C. For fine edging on light to medium fabric. (handkerchief edging)
 Eg : Handkerchief & dress ...etc.



A

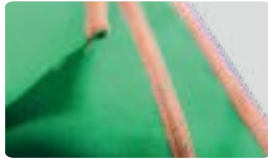

B



C

选购配件 OPTIONAL DEVICE
VT, TUA

L3 Device

747L-514M-3-2⑦/TG/(⑨)	2	4	2	4.5	0.7~2	3.6	5.5	H / U	7500

肩带包缝

适用于针织衣服如T恤、毛衣等的肩部多车一条织带, 可防止衣服肩部变形。

TAPE INSERTING

For sewing a woven tape onto the shoulder of knitwear such as T-shirt or sweater etc., to prevent abnormal stretching.



747L-514M-3-24/TG/EC

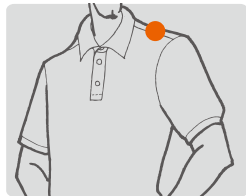

选购配件 OPTIONAL DEVICE
EC, LFA, LS

规格 SPECIFICATIONS 747L-514 M - 8 - 2 4 / GA / DKLU

规格索引, 详细请参考P.31 Specification index, please refer to P.31

- ① 线数 Thread numbers
- ② 机种别 Model
- ③ 缝合方式 Sewing types
- ④ 车缝布料/上勾针缝容量 Sewing fabric/Upper looper capacity
- ⑤ 送具型式 Feed dog type
- ⑥ 针距 Needle gauge
- ⑦ 包边宽度 Overedge width
- ⑧ 配件 Device
- ⑨ 马达 Motor
U: U Series
H: H Series

L4 Device

737L-505F-2-04/(⑨)	1	3	-	4	0.7~2	3.6	5	H / U	7500



拷下摆

用于特薄至薄布料的针织T恤、内衣等的下摆或袖口拷缝。

BLIND HEMMING

For hemming sleeves and bottoms of T-shirts or underwear etc. Applicable for light to extra light fabric.

选购配件 OPTIONAL DEVICE
VT, TUA

L5 Device

747L-503M-2-23/(⑨)	1,2	2,3	-	3	0.7~2	-	6	H / U	6500



鱼骨缝

适用于不同厚度、弹性的布料。布料透过鱼骨缝拷克缝制, 可以容易地将布料摊平, 并在布料上呈现整齐且均匀的鱼骨缝线迹, 同时增加缝制产品的美观性与舒适性。

FISHBONE STITCH

Suitable for fabrics of different thickness and elasticity. Sewing with fishbone stitch can easily flatten the fabric, so that the stitches can be neatly placed on the fabric, which is good looking and comfortable to wear at the same time.

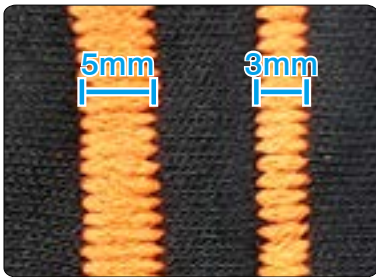

鱼骨缝宽度:

鱼骨缝拷克具有较好的操作性与调整性, 可依据缝制包边宽度需求, 选用单左针车缝或单右针车缝。使用单左针车缝, 其鱼骨缝宽度为5mm; 使用单右针车缝, 其鱼骨缝宽度为3mm。

Width of fishbone stitch :

Fishbone stitch has good operability and adjustability. You can choose single left needle sewing or single right needle sewing according to the sewing width requirement. The width of fishbone stitch is 5mm with single left needle; the width of fishbone stitch is 3mm with single right needle.

规格 SPECIFICATIONS 747L-514M-8-2 4/GA/ DKLU

规格索引, 详细请参考P.31 Specification index, please refer to P.31

- ① 线数 Thread numbers
- ② 机种别 Model
- ③ 缝合方式 Sewing types
- ④ 车缝布料/上勾针缝容量 Sewing fabric/Upper looper capacity
- ⑤ 送具型式 Feed dog type
- ⑥ 针距 Needle gauge
- ⑦ 包边宽度 Overedge width
- ⑧ 配件 Device
- ⑨ 马达 Motor
U: U Series
H: H Series

L6 Device

	①	②	③	④	⑤	⑥	⑦	⑧	⑨	⑩ S.P.M. (Max)
747L-514M-8-24/GA/(⑨)	2	4	2	4	0.7~2	3.6	5.5	H / U		7000
757L-516M-8-35/GA/(⑨)	2	5	3	5	0.7~2	3.6	5.5	H / U		7000
757L-516M-8-55/GA/(⑨)	2	5	5	5	0.7~2	3.6	5.5	H / U		7000



757L-516M-8-35_GA



GA

折景车缝

适用中厚布料下层布间歇或连续性不规则折景车缝, 可加滚边喇叭增加车缝品质如裙子, 床罩, 窗帘等。

GATHERING

Continuous or intermittent random gathering on lower ply of medium fabric, can be equipped with piping folder to increase sewing quality for shirt, bed sheets, curtains etc.

选购配件 OPTIONAL DEVICE
EC, FG, VT, CT, TUA

L7 Device

	①	②	③	④	⑤	⑥	⑦	⑧	⑨	⑩ S.P.M. (Max)
737L-504M-3-04/LFC-3	1	3	-	4	0.7~2	3.6	6	U		4500
747L-514M-3-2⑦/LFC-3	2	4	2	4,5	0.7~2	3.6	5.5	U		4500
737L-WR/LFC-3	1	3	-	-	-	-	-	-		4500



747L-514M-3-24/LFC-3

松紧带车缝

利用送带装置控制松紧带的张力, 适用于泳衣、内衣裤或运动服饰的松紧带包缝。

LFC-3: 机械式送带, 多样的压脚可供选择。

SMK: 电子计数式送带

SMK1-A-01 附定位器, 适合简易伺服或离合器马达。

SMK1-A-02 以中继线连接伺服马达。

ELASTIC ATTACHING

Tape feeding device controls the tension. Applicable to swimming wear, underwear, sports wear's elastic band attaching.

LFC-3: Mechanic type elastic tape feeding various presser feet for optional demand.

SMK: Electric metering type elastic tape feeding **SMK1-A-01** with synchronizer for simple servo motor or clutch motor.

SMK1-A-02 Connected to servo motor by encoder cable.

	737L		747L		
压具 Presser foot	P216-3	P216-4	P217-4	P218-4	P219-4
松紧带宽度 Band width	2mm~13mm	2mm~13mm	Max. 20mm	Max. 30mm	Max. 35mm
备注 Remark	标配 Standard		选配 Optional		

选购配件 OPTIONAL DEVICE
EC, LFA, LS



737L-WR/LFC-3

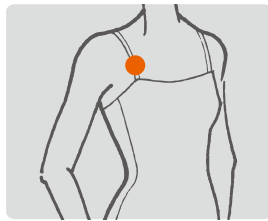

LFC-3

管状布条车缝

将针织布条拷边车缝后再反条成管形，适用于各种泳装，睡衣或韵律服等管状肩带。

注：标准喇叭的布条入布宽度22mm(7/8")成型的管状布条直径为5mm。

SPAGHETTI SEWING

To sew knit fabric tape and turn over it into spaghetti tube for swimwears, nightgowns etc...

Remark : Standard folder specification: tape width is 22mm (7/8") and the finished tube size is about 5mm in diameter.

选购配件	OPTIONAL DEVICE
	FG

规格 SPECIFICATIONS 737L- 504 M -7- 0 4/ BK/ DKLU

规格索引，详细请参考P.31 Specification index, please refer to P.31

- ① 线数 Thread numbers
- ④ 车缝布料/上勾针缝容量 Sewing fabric/Upper looper capacity
- ⑥ 针距 Needle gauge
- ⑨ 马达 Motor
U: U Series
H: H Series
- ② 机种别 Model
- ⑤ 送具型式 Feed dog type
- ⑦ 包边宽度 Overedge width
- ⑧ 配件 Device

L8 Device

		①	④	⑥	⑦	⑧	⑨	S.P.M. (Max)
手动 Manual	737L-504M-7-04/BK/(⑨)	1	3	-	4	0.7~2	3.6	6 H / U 7500
	747L-514M-7-2⑦/BK/(⑨)	2	4	2	3,4	0.7~2	3.6	5.5 H / U 7500
	747L-514H-7-2⑦/BK/(⑨)	2	4	2	4,5	0.7~2	3.6	7 H / U 6500
简易式全自动 Simplified Fully Auto	747L-514M-3-24/ECA/BKT/⑨	1	3	-	4	0.7~2	3.6	7 H / U 7000
全自动 Fully Auto	737L-504M-3-0⑦/BKF1	1	3	-	4	0.7~2	3.6	6 H / U 6500
	747L-514M-3-2⑦/BKF1	2	4	2	4	0.7~2	3.6	5.5 H / U 6500



747L-514M-7-24/BK



747L-514M-3-24/ECA/BKT



747L-514M-3-24/BKF1



线头包缝

将线头包入车缝线内，可防止缝合的开口处缝线脱落，适用于内衣裤，运动服的袖口及侧边缝合。

BACK LATCHING SEAMING

To prevent seam looseness, turn over the thread and then insert into overlock seaming at the beginning of sewing. For sleeve and sideways sewing of underwear, sportswear etc.

操作 Operation	配件代号 Code	说明 Description	适用机头 Applicable Series	驱动方式 Drive Type
手动 Manual	BK	Rotary Plate 	737L 747L	建议搭配伺服马达， 使用定针功能， 提升车缝效率 To equip with servo motor for needle position function is optional and recommended.
简易式全自动 Simplified Fully Auto	BKT	1. 简易式，线头长度约3cm 2. ECA切刀，针板有特殊风道设计，线头向下吸回 1. Simplified type, back latch length 3cm. 2. With ECA cutter, needle plate suction channel for thread-end down turning.	747L	700L电控系统 气动式 700L : Pneumatic type servo control system
自动 Fully Auto	BKF1	1. VT吸风切线 2. 可设定多种操作模式 3. 线头侧向吹回，长度可以调整 (最短1cm) 1. With VT suction trimmer 2. Multi-operation mode setting 3. Thread-end side turning. Back latch length is adjustable (Min. 1cm)	737L 747L	BKF1专用伺服控制系统 气动式 BKF1 : Pneumatic type servo control system

规格

SPECIFICATIONS

737L- 514 H -4- 2 4/ DKLU

规格索引, 详情请参考P.31 Specification index, please refer to P.31

- ① 线数 Thread numbers
- ② 机种别 Model
- ③ 缝合方式 Sewing types
- ④ 车缝布料/上勾针缝容量 Sewing fabric/Upper looper capacity
- ⑤ 送具型式 Feed dog type
- ⑥ 针距 Needle gauge
- ⑦ 包边宽度 Overedge width
- ⑧ 配件 Device
- ⑨ 马达 Motor
U: U Series
H: H Series

L9 Device

	①	②	③	④	⑤	⑥	⑦	⑧	⑨	S.P.M. (Max)
747L-514H-4-24/ (⑧)/ (⑨)	2	4	2	4	0.7~2	3.6	7	H / U	6500	
747L-514H-4-25/ (⑧)/ (⑨)	2	4	2	5	0.7~2	3.6	7	H / U	6500	
757L-516H-3-5⑦	2	5	5	5,6	0.7~2	3.6	7	H / U	6000	
757L-516X-3-5⑦	2	5	5	5,6	0.7~2	3.6	7	H / U	6000	



747L-514H-4-24/TG/EC



757L-516X-3-56



TG/EC

厚毛衣料肩带包缝

适用于毛衣的肩部多包缝一条平织布条, 可防止衣服肩部变形
注: 布条装置的导板使用, 布条最大宽度为1/4"(6.35mm)。

TAPE INSERTING ON BULKY KNITWEAR

For sewing a woven tape onto the shoulder of knitwear such as sweater, to prevent abnormal stretching.
Remark: Max. width of tape is 1/4"(6.35mm)

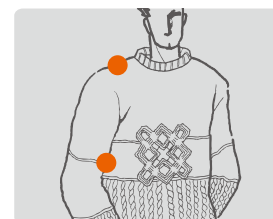

TG/EC 选购配件 OPTIONAL DEVICE
LFA, LS



514H4

厚毛衣料包缝

适用于粗厚毛线衣物车缝。

OVER SEAMING ON BULKY KNITWEAR

For regular seaming on bulky knit fabric such as sweater.

514H4 选购配件 OPTIONAL DEVICE
CT, TUA



516X-3

牛仔包缝

特殊传动行程结构适用于牛仔布料的包缝, 例如: 牛仔布 & 工作服。

DENIM OVERLOCK

Special driving mechanism for seaming on denim fabric such as jeans, workwears etc.



516X3 选购配件 OPTIONAL DEVICE
CT, TUA

规格

SPECIFICATIONS

757L- 516 M -3- 3 5/ PS / DKLU

规格索引, 详细请参考P.31 Specification index, please refer to P.31

- ① 线数 Thread numbers
- ② 机种别 Model
- ③ 缝合方式 Sewing types
- ④ 车缝布料/上勾针缝容量 Sewing fabric/Upper looper capacity
- ⑤ 送具型式 Feed dog type
- ⑥ 针距 Needle gauge
- ⑦ 包边宽度 Overedge width
- ⑧ 配件 Device
- ⑨ 马达 Motor
U: U Series
H: H Series

L10 Device



757L-516M-3-35/PS/(⑨)	2	5	3	5	0.7~2	3.6	5	H / U	7000
757L-516M-3-55/PS/(⑨)	2	5	5	5	0.7~2	3.6	5	H / U	7000
757L-401M-8-⑥0/TA/(⑨)	2	4	3.5	-	0.7~2	3.6	5	H / U	7000



757L-516M-3-35/PS



757L-401M-8-50/TA

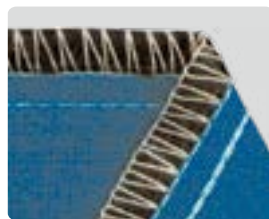

PS



TA

口袋边包缝

PS: 在裤袋边缘缝包边布条, 以强化缝合处, 增加美观。
注: 标准喇叭的人布宽度为3/8"(9.5mm)

TA: 双勾针机型, 适用于裤袋边缘加包边布条, 车缝两道环缝线以强化缝合处并增加美观。
注: 标准喇叭(人布宽度25.4mm/出布宽度6.4mm)

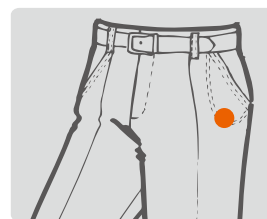

POCKET BINDING

PS: To insert an extra tape to cover on the edge of pocket then by safety stitching for strengthening the pocket seaming. Suitable for high quality trousers.
Remark : Standard folder for tape width is 3/8"(9.5mm)

TA: Two needle two chainstitches. Tape binding by two chainstitch on the edge of pocket of high quality trousers.
Remark : Standard folder (tap width 25.4mm/finish width 6.4mm)

选购配件 OPTIONAL DEVICE

EC* . FG



*注: EC仅可搭配PS

* Remark : EC only for PS

OVERLOCK SEWING MACHINE

700KST 700KS 700KT

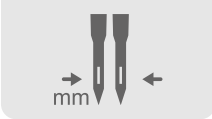
747 KST - 514 M - 3 - 2 - 4 / VT

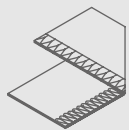
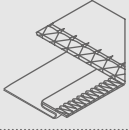
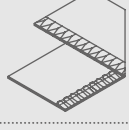
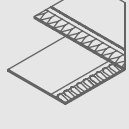
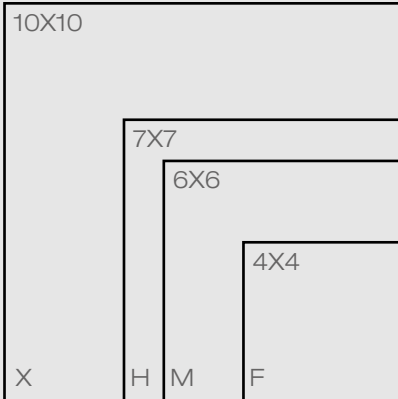
<p>①线数 Thread Numbers</p> <p>737 : 3T 747 : 4T 757 : 5T</p>			<p>⑥针距 Needle Gauge</p> 	<p>⑦包边宽度 Overedge Width</p> 	<p>⑧配件 Device</p>
<p>②机种别 Model</p> <p>KST 筒型上送 Cylinder-Bed Top-Feed</p> <p>KS 筒型 Cylinder-Bed</p> <p>KT 上送型/安全缝 Top-Feed/Safety Stitch</p>	<p>③缝合方式 Sewing Types</p> <p>504 </p> <p>505 </p> <p>514 </p> <p>516 *For KT </p>	<p>④车缝布料/上勾针缝容量 Sewing Fabric/Upper Looper Capacity</p> <p>F 轻薄布料 Fine Weight Fabric</p> <p>M 中厚布料 Medium Weight Fabric</p> <p>H 厚布料 Heavy Weight Fabric</p> <p>X 特厚布料 *For KT Extra Heavy Weight Fabric</p> 	<p>⑤送具型式 Feed Dog Type</p> <p>2 2排 (标准) 2 Row (Standard)</p> <p>3 3排 (标准) 3 Row (Standard)</p> <p>4 4排 (标准) 4 Row (Standard) *For KT</p>		

OVERLOCK DD SERVO MOTOR

747KST-514M-3-24 / VT / DKK□□

⑨DKK□□ 700KST/700KS/700KT型直驱电控组
Direct Drive Servo Motor for 700KST/
700KS/700KT
请参阅P.57 Detail on Page.57

700KS/KST series FEATURES

700KS 高速筒型包缝机
High Speed Cylinder Bed Overlock Sewing Machine

700KST 高速筒型上送包缝机
High Speed Cylinder Bed Top Feed Overlock Sewing Machine

延续700K系列的特点，发展筒型机构延伸成为700KS系列。再增加新型独立驱动的上送具机构，延伸成为700KST系列

Succeeding 700K Series' features, we develop cylinder bed mechanism to extend to 700KS Series. Moreover, with brand new independent-drive top feed mechanism, it extends to 700KST Series.

- 筒嘴周长: 148mm · Cylinder Bed Circumference: 148mm
- 缝距调整: 按钮式 · Stitch Length Adjustment: Push-button
- 差动比调整: 手杆式 · Differential Feed Ratio Adjustment: Lever type
- 润滑系统: 全自动 · Lubrication: Fully-automatic



规格

SPECIFICATIONS

737KS - 504 M - 3 - 0 4 / LFD6-K1 /DKKU

- ① 线数 Thread numbers
- ② 机种别 Model
- ③ 缝合方式 Sewing types
- ④ 车缝布料/上勾针缝容量 Sewing fabric/Upper looper capacity
- ⑤ 送具型式 Feed dog type
- ⑥ 针距 Needle gauge
- ⑦ 包边宽度 Overedge width
- ⑧ 配件 Device
- ⑨ 马达 Motor
U: U Series
H: H Series

700KS Device

		①	②	③	④	⑤	⑥	⑦	⑧	⑨	⑩	⑪
下摆盲缝 Blindstitch Hemming	737KS-505F-2-04/⑨	1	3	-	4	0.7~2.0	3.8	5	#9	6500		
一般包缝 General Sewing	737KS-504M-3-0⑦/⑧/⑨	1	3	-	3,4,5	0.7~2.0	3.8	5	#11	6500	VT RLK-□ LFD6-K1 LFD6A-K1	
	737KS-504H-3-0⑦/⑧/⑨	1	3	-	3,4,5	0.7~2.0	3.8	6	#11	6300		
	747KS-514M-3-2⑦/⑧/⑨	2	4	2	3,4,5	0.7~2.0	3.8	5	#11	6500		
	747KS-514H-3-2⑦/⑧/⑨	2	4	2	3,4,5	0.7~2.0	3.8	6	#11	6300		

700KST Device

		①	②	③	④	⑤	⑥	⑦	⑧	⑨	⑩	⑪	
下摆盲缝 Blindstitch Hemming	737KST-505F-2-04/⑨	1	3	-	4	0.7~2.0	0.5~6	3.8	5	#9	6300		
一般包缝 General Sewing	737KST-504M-3-0⑦/⑧/⑨	1	3	-	3,4,5	0.7~2.0	0.5~6	3.8	5	#11	6300	VT RLK-□	
	737KST-504H-3-0⑦/⑧/⑨	1	3	-	3,4,5	0.7~2.0	0.5~8	3.8	6	#11	6000		
	747KST-514M-3-2⑦/⑧/⑨	2	4	2	3,4,5	0.7~2.0	0.5~6	3.8	5	#11	6300		
	747KST-514H-3-2⑦/⑧/⑨	2	4	2	3,4,5	0.7~2.0	0.5~8	3.8	6	#11	6000		

上圆领系列

CIRCULAR COLLAR ATTACHING SERIES

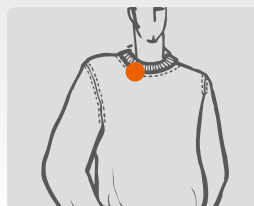

RSK

圆领及裤头车缝装置

Circular collar & Waistband attaching device



1. 气动式导布装置，左右两侧紧靠圆领布带，配合滚轮撑开组，使得圆领布带能够稳定的前进，车工只需控制布身裁片，提升效率，降低车缝工序的难度。
2. 分布装置透过拨杆感测装置，可控制布料避免移动走位。
3. 搭配贺欣直驱节能马达。

*适用圆领、裤头车缝。

1. Pneumatic fabric guide set holds the neckband's right and left side. With tubular extending roller set, the neckband tape can move forward stably so that operators can focus on fabric control, which improves the efficiency and reduces the difficulty of sewing operation.
2. The alignment device makes fabric edge aligned, shift-free during sewing.
3. Equipped with Hohsing direct drive energy saving motor.

*For circular collar & waistband sewing.

ACS

自动上圆领装置

Automatic circular collar attaching device



在气动导布与滚轮撑开的基础上，加上自动顺布条，接缝骨自动定位，减少90%的上料时间。

Based on Pneumatic tape guide and tubular extending roller set, with advanced function as Automatic tape alignment, automatic Joint-seam positioning, which reduce 90% material loading time.

- 1** 自动侦测缝骨位置，减少工人对位时间。
Auto detect the collar seam, by sensor. shorten the rib marking time.
- 2** 可调式张力控制机构，减少布料起皱现象。
Tubular tension control system avoids puckering.
- 3** 导布结构，缝合衣领与布身时，防止偏斜。
Guiding platform ensures a quality joint of rib and fabrics.
- 4** 电眼控制导布装置自动开合。
Automatically control the fabric guider.

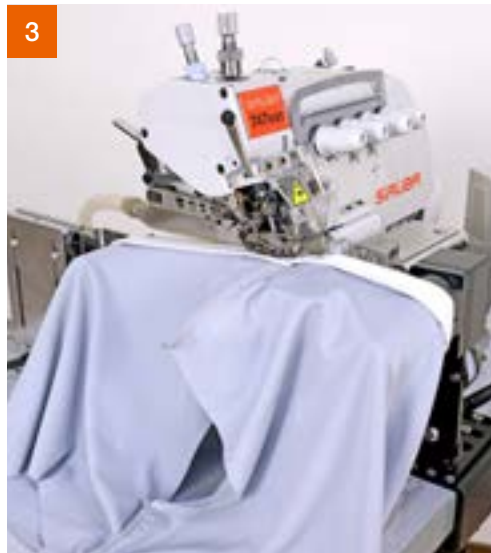

型号 Model	ACS200	领围车缝范围 Applicable Collar Circumference	
搭配缝纫机机头 Machine Head	747KST-514M-3-24/VT		
车缝速度 Sewing Speed	4500 SPM (最高 Max)	领高车缝范围 Applicable Collar Height	Single Phase 1φ AC200~240V 50/60Hz
使用布料 Type of Fabric	弹性布料 Elastic fabric		
布厚车缝范围 Applicable Cloth Thickness	对折后 1.2 mm ±0.2 mm After fold 1.2 mm ±0.2 mm	电源电压 Power Supply	650 W (Max)
气体消耗量 Air Consumption	150 公升 / 分 150 L/min	电力消耗 Power Consumption	
气压 Air Pressure	0.5 MPa	生产效率 Production Capacity	



LFD6-K1 多功型自动松紧带包缝(700KS 适用)
LFD6A-K1 Multi-function computerized automatic elastic attaching
 (700KS Applicable)

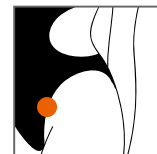

对于松紧带的包缝，可利用电脑控制自动切带与自动送带。可设定多段的松紧度与车缝长度，适用于泳衣、紧身衣、内裤等小口径松紧带上带车缝。

For attaching elastic tape on small openings of swimsuit, leotards or brief, etc. By computer control, with auto cutting and auto tape feeding, elastic tape sewing can be done by multi-section tension and length.



送具下沉功能：

压脚抬起时，送具自动下沉，确保送带零干扰。

Feed dog dropping function : when presser foot lifts, the feed dog drops to ensure tape feeding without obstacle.

直驱伺服马达：

电控功能高度整合，动作配合更准确。

Direct drive servo motor : Electrics highly integration realizes the accurate series movements.

送带 / 切带功能

- 自动、手动、测试，三种操作模式。自动/手动换段，配备LED段数灯号
- 送带准确，以mm为单位设定送带长度
- 可调式前送带，延迟送带，倒带功能，前送带时可追加倒带的功能
- 送带速度补偿，10组预设值可供选择
- 因应实际车缝状况，车缝中可手动强制送带/倒带。车缝中遇失败，可自动/手动调整至原工程第一段
- 吹气送带功能

TAPE FEEDING / CUTTING

- 3 operation modes: Auto, Manual, and Test. Auto/ Manual section changing with LED indicate lamp.
- Precise feeding and the length setting unit is mm.
- Adjustable feeding of forward, delay, reverse, and forward feeding with reverse function.
- Speed compensation with 10 default values for choice.
- For different sewing situations, active feeding may be applied by forward/ reverse when sewing. If sewing operation failed, auto/ manual return to the first section of sewing program.
- Air blow tape feeding function.

设定 / 记忆功能

- 连续缝记忆组数：10组
- 工程段数：18段
- LCD面板显示设定状况、操作模式、错误代码
- 触控面板：图形界面，设定更容易，添加测试模式，更快上手



SETTING / MEMORY

- Memory of sewing program set: 10 sets
- Program section: 18 sections.
- LCD panel shows setting status, operation mode, and error code.
- Touch panel : Graphical user interface is easy for setting. New added testing mode is easy for beginner.

其他附属功能

- 松线功能
- 吸风切线的省风节能：起始/结束吸风时间可以调整（以针数计算）
- 回踩自动抬压脚功能

Additional Function

- Thread releasing
- Suction thread chain cutters energy saving: Starting/ Ending air suction's time is adjustable.(by stitch counting)
- Auto presser foot lifting by paddle step-back.

LFD6-K1 & LFD6A-K1 规格 / SPECIFICATION



连续缝记忆组数 Program set memory	10组 10 sets
每组连续缝工程段数 Sections of every program	18段 18 sections
送带距离/每针 Tape feeding length per stitch	0.2mm ~ 6.5mm
最高缝速(送距5mm) Max. Speed (stitch length 5mm)	4200 R.P.M
送带马达 Tape feeding motor	五相步进马达 5-phase stepping motor
工作电压 Voltage	AC 110~220 V

选配 / DEVICE



LFD6-A



LFD6-AA



LF290

LFA

* 标准配备不列入机型名称
*Standard devices are not mentioned in model name.

Code	Description	Remark
LFD6-A	短滚轮: 适用16mm以下的松紧带 Short roller: for tape width 16 mm below	LFD6-K1 标配 LFD6-K1 Standard
LFD6-AA	长滚轮: 适用16mm~50mm的松紧带 Long roller: for tape width range 16mm~50mm	LFD6A-K1 标配 LFD6A-K1 Standard
LFA	电动式上送带装置 Electric tape feeding device Voltage, 110V(Part NO.LFA-1A) / 220V(Part NO.LFA-2A)	选配 Optional
LF290	抖带轮 Euntangling wheel Voltage, 110V(Part NO.LF290-A1) / 220V(Part NO.LF290-A2)	选配 Optional
VT*	垂直式自动吸风切线 Vertical Pneumatic chain cutter	标配 Standard
TU*	空气控制阀/集尘装置 Dust collector suction device	标配 Standard



RLK1

筒型撑开轮组

Tubular Extending Roller set

·前后撑开, 搭配一般桌板
·Diagonal extending roller with closed table top



RLK2

筒型撑开轮组

Tubular Extending Roller set

·前后撑开, 搭配开口式桌板
·Diagonal extending roller with open table top



RLK3

筒型撑开轮组

Tubular Extending Roller set

·三点式撑开, 搭配开口式桌板
·Three point extending roller with open table top



RLK3P

筒型撑开轮组(气动)

Tubular Extending Roller set (pneumatic)

·三点式撑开, 搭配开口式桌板
·Three point extending roller with open table top
·建议组合 Recommend Package
TUA-38S(ST) / DKH201ADE-A / 700KS-T3-P

700KT SERIES FEATURES



700KT 高速上送包缝机 High Speed Top Feed Overlock Sewing Machine

延续700K系列的特点，增加新型独立驱动的上送具机构，延伸成为700KT系列。

Succeeding 700K Series' features, we develop brand new independent-drive top feed mechanism, to extend to 700KST Series.

- 缝距调整: 按钮式
- 差动比调整: 手杆式
- 润滑系统: 全自动

- Stitch Length Adjustment: Push-button
- Differential Feed Ratio Adjustment: Lever type
- Lubrication: Fully-automatic

规格 SPECIFICATIONS

① ② ③ ④ ⑤ ⑥ ⑦ ⑧ ⑨ 737KT - 504 M - 3 - 0 4 / VT /DKKU

规格索引，详细请参考P.49 Specification index, please refer to P.49

- | | | | |
|---------------------|--|-----------------------|--|
| ① 线数 Thread numbers | ④ 车缝布料/上勾针缝容量
Sewing fabric/Upper looper capacity | ⑥ 针距 Needle gauge | ⑨ 马达 Motor
U: U Series
H: H Series |
| ② 机种别 Model | ⑤ 送具型式 Feed dog type | ⑦ 包边宽度 Overedge width | |
| ③ 缝合方式 Sewing types | | ⑧ 配件 Device | |

700KT Device

		①	⑥	⑦							⑧	
												选购配件 OPTIONAL DEVICE
一般包缝 General Sewing	737KT-504M-3-0 ⑦/⑧/⑨	1	3	-	4,5	0.7~2.0	1~6	3.2	5	#9	7000	VT
	747KT-514M-3-2 ⑦/⑧/⑨	2	4	2	3,4,5	0.7~2.0	1~6	3.2	5	#11	6700	VT
折景车缝 Shirring/Gathering	747KT-514H-3-2 ⑦/⑧/⑨	2	4	2	3,4,5	0.7~2.0	1~8	3.2	6	#11	6300	VT,GA
松紧带车缝 Tape Attaching	747KT-514H-4-2 ⑦/⑧/⑨	2	4	2	3,4,5	0.7~2.0	1~8	3.2	6	#11	6300	VT
一般包缝 General Sewing	757KT-516M-3-3 ⑦/⑧/⑨	2	5	3	4,5	0.7~2.0	1~6	3.2	6	#14	6700	CT
	757KT-516M-3-5 ⑦/⑧/⑨	2	5	5	5,6	0.7~2.0	1~6	3.2	6	#14	6700	CT
松紧带车缝 Tape Attaching	757KT-516H-3-5 ⑦/⑧/⑨	2	5	5	5,6	0.7~2.0	1~7	3.2	7	#21	6300	CT,GA
特厚布 Extra Heavy	757KT-516X-3-5 ⑦/⑧/⑨※	2	5	5	6,7	0.7~2.0	1~7	3.2	8	#21	5500	CT

※ 搭配厚料修布角刀
With heavy material angle knife.

DEVICE



BK

包线头装置 Back Latching

将线头一起包入车缝，可防止缝合开口处(如袖口)的缝线脱落。

- KD207手轮: 订机头有装此零件以配合定针用，若个别订购BK组则依需要订购
- 包含BK232车布导板

To prevent seam looseness, turn over the thread and then insert into overlock seaming at the beginning of sewing.

- KD207 hand wheel: standard equipment of 700K/BK machine, optional for BK device.
- Including BK232 sewing bed .

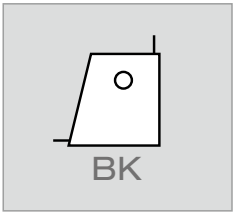

可自行组装 self-installation : YES

适用机型 applicable model : 737L-504M-7, 747L-514M-7, 747L-514H-7

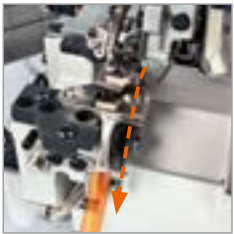

BKT

简易式自动包线头 Simply Auto Back Latch

为ECA延伸功能，车缝效率极高，针板有特殊风道设计，线头在切线后，瞬间吸回，线头长度约3cm。

It is an ECA extending function, the sewing efficiency is extremely high. The needle plate is specially designed with a suction channel to quickly retract the thread after trimming. The thread length is approximately 3cm.



可自行组装 self-installation : NO

适用机型 applicable model : 747L-514M-3-24/ECA/BKT



CT

下吸式切线装置 Flat Suction Thread Chain Cutter Device

利用吸风式马达或空压机，将线吸入切刀槽中予以切断(较适用于4~6线的机型)。

Take thread into trimmer tube by suction motor or air compressor.
(Applicable for 4~6 thread machine)

可自行组装 self-installation : YES

适用机型 applicable model : 767L



**CTE
CTE-U**

**下吸式自动切线装置 (附电眼节能装置)
Flat Suction Auto Thread Chain Cutter Device(with Sensor-controlled Energy-saving Device)**

以电眼侦测布边，控制吸风功能在切线时运作，减少空压设备的能源消耗，并避免缝线浪费

1. 垂直式吸风切线适合内裤等轻薄及不规则的针织面料车缝，提升效率
2. 切刀的吸风口的设计使得切线更加快速
3. 针对网纱、强反光丝光棉等特殊面料，采用专业的电控程式控制，均能轻松车缝及完成切线，不会造成切刀误切
4. 「切线后自动停车功能」以及「无面料即不车缝功能」可减少缝线的浪费
5. VTA以气缸推动切刀，减少刀刃磨损，大幅延长使用寿命

Sensor checks the fabric edge. It saves the energy consuming of air compressor system and also saves thread consuming.

1. Vertical suction trimming is suitable for sewing the light fabric like under-wear or irregular knitwear, to improve the efficiency.
2. The design of the suction inlet of the trimmer makes the trimming faster.
3. For those special fabrics such as mesh fabric, mercerized cotton etc, the stitches are easily accomplished as well as the trimming by the professional computer controlled without mistake-trimming.
4. Functions with auto stop sewing after trimming and with no fabric can save the stitches.
5. VTA trimmer is controlled by air cylinder, which reduces the blade stroke times and extends the durability.

	前/中电眼 Front/middle sensors	抬压脚 Foot Lifter	气动配件Pneumatic Set	
			吸风集尘组 Suction Set	吸风线槽 Suction Channel
CTE	V	气动 Pneumatic	V	V
CTE-U	V	气动 Pneumatic	V	V

可自行组装 self-installation : NO

适用机型 applicable model : 747L, 757L, 747LQ, 757LQ



**DKL 12
DKK 12**

直驱伺服马达 Direct Drive Servo Motor

包缝机模块化搭配直驱伺服马达，多样化的选择，更有弹性。

1 = 厂商代码 2 = 版本代码 + 功能代码

Overlock Sewing Machine equipped with the modularized direct drive servo motors to be more flexible for diversification.

1 = Manufacturer code 2 = Version code + Function code

可自行组装 self-installation : YES

适用机型 applicable model : 全系列包缝机 All Overlock Series



EC

电动式切布条/松紧带条装置 Electric Type Tape / Elastic Cutter

利用手动按钮方式切断松紧带，不织布条或滚边布条。

1. 分标准切刀EC-K (16 mm) · 长切刀EC-K-A (22 mm)。
2. 标准为手动切带，另可选购膝控切带(FEC34-A)。

Cuts tape/ elastic by pressing the button.

1. EC-K: Standard knife (16 mm") EC-K-A: Long knife (22 mm")
2. Hand-control button : standard Knee-control paddle (FEC34-A) : Optional

可自行组装 self-installation : YES

适用机型 applicable model : MODEL w/LFC-3, MDDEL w/PS, MODEL w/TG



ECA
ECB

气动式切刀 (自动模式切换功能/附手动)
Pneumatic Type Tape / Thread Cutter (with Auto / Manual Switch Function)

电动式切刀 (自动模式切换功能/附手动)
Solenoid Type Tape / Thread Cutter (with Auto / Manual Switch Function)

采用新一代的电眼，性能再升级。ECA为气动式，ECB为电动式，搭配吸风线槽，操作更顺畅。

- 1.手动、半自动及全自动操作模式，附转换按键，且可透过操作面板调整。
- 2.防误切保护装置:切刀旁安装一电眼，如有被遮挡的状况下，切刀不会动作，能有效地防止切刀误切到布料。
- 3.手动切线补偿按键，如因操作问题没有切断线，可由此按键进行手动切线。
- 4.手动模式下，可后踩踏板切线。
- 5.针对网纱、强反光丝光棉等特殊面料，采用专业的电控程式控制，均能轻松车缝及完成切线，不会造成切刀误切。

Brand new sensor upgrades the performance. ECA is pneumatic type, and ECB is electric type, compatible with air suction slot, which makes the operation more smoothly.

1. Manual, semi-auto and fully-auto operation mode, attached the switch keys, and could be adjusted by the panel.
2. Mistake-proof protection device: One sensor equipped near the trimmer. If the sensor is blocked, the trimmer is deactivated effectively for avoiding from cutting the fabric.
3. Manual trimming compensation stitch key: If the thread is not cut due to the operation, it can be done by the key.
4. Under the manual mode, it could be fully backward pedaled to cut the thread.
5. For those special fabrics such as mesh fabric, mercerized cotton etc, the stitches are easily accomplished as well as the trimming by the professional computer controlled without mistake-trimming.



ECA



ECB



	三电眼 Three sensors	切刀 Cutter	抬压脚 Foot Lifter	气动配件Pneumatic Set	
				吸风集尘组 Suction Set	吸风线槽 Suction Channel
ECA / ECA-U	√	气动 Pneumatic	气动 Pneumatic	√	√
ECB / ECB-U	√	电动 Electric	电动 Electric	√	√

可自行组装 self-installation : NO

适用机型 applicable model : 737L, 747L 757L, 767L, 737LQ, 747LQ, 757LQ



FG

侧带盘 Side Tape Holder

置于桌板右侧放布条用

For tape feeding, on the right side of the table.

可自行组装 self-installation : YES

适用机型 applicable model : MODEL w/PS, MODEL w/TA



GA

折景装置 Gathering Device

下层布间歇或连续性不规则折景。

P滚边器(喇叭)KV57(入布宽度25mm/出布宽度6mm)依需要可另订，若滚边加绳需另订压具(压具底需磨一条沟)，为一般压具代号多加P，如：P204P。

Continuous or intermittent random gathering on lower ply.

P: Piping folder KV57 (tape width 25mm / finish width 6mm) is optional. For piping with rope inside, presser foot requires a trench, which is marked with P at the end of parts code. eg P204P.

可自行组装 self-installation : YES

适用机型 applicable model : 747KT-514H, 747L-514M-8, 747L-516M-8



GAS 折景压脚 Gathering Presser-foot

下层布间歇或连续性不规则折景。料号：ZGL04-P324-A。
Continuous or intermittent random gathering on lower layer of fabric.
Part NO. ZGL04-P324-A

可自行组装 self-installation : YES
适用机型 applicable model : 747L-514M



GAL 荷叶边密拷装置 Flounce/Falbala fine edging

弹性布料密合时，以压布杆向下压住布料边缘，形成向后拉力，而产生荷叶边造型，可调整压力产生不同的波浪效果。
Elastic fabric fine serging with a pull-back device makes flounce/ falbala style.
Adjust the pressure of pull-back plate to have big or small waves.



可自行组装 self-installation : YES
适用机型 applicable model : 737L-504F-2



KB301 简易防卷边装置 Simple anti curly selvedge device

安装容易，透过装置有效辅助卷曲布料工段的车缝。
Easy to install, effectively solve curly selvedge problem.

可自行组装 self-installation : YES
适用机型 applicable model : MODEL 700L, MODEL 700LQ, MODEL 700KT

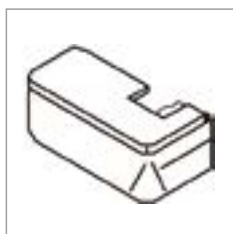

KB561-A 平台式车布导板 Flat Bed Cloth Plate

将筒型车改为平台式，方便于非筒型衣物包缝。
To convert cylinder bed machine into flat bed machine. For normal overlock sewing operation.

可自行组装 self-installation : YES
适用机型 applicable model : 700KS



FA 侧向电动送带装置 Side Electric Tape Feeding

1. 利用电子微动开关控制布条，松紧带或蕾丝的输送长度，使上带车缝更加平顺。
2. 送带在控制箱右边。
1. With electronic switch to control the feeding length of tape, elastic, or lace to create smoother sewing.
2. Tape feeding will be on the right hand side of the control box.

可自行组装 self-installation : YES
适用机型 applicable model : 700L



LFA

电动式直向送带装置 Electric Type Upper Tape Feeding Device

利用电子马达带动松紧带，使其放松到零松紧状况，并可控制所需松紧带的长短，使车缝时松紧度能一致。

电压：110V(Part NO. LFA-1A) / 220V(Part NO. LFA-2A)

To keep constant tension for sewing. Elastic tape is fed by motor for zero tension and required length.

Voltage, 110V(Part NO. LFA-1A) / 220V(Part NO. LFA-2A)

可自行组装 self-installation : YES

适用机型 applicable model : MODEL w/LFC-3, MODEL w/TG



LF290

抖带轮 Untangle Wheel

可选配安装于LFA (送带装置)，以逆转的方式，抖动松紧带，做为送带前的处理。

电压：110V(Part NO. LF290-A1) / 220V(Part NO. LF290-A2)

An optional device to be equipped with LFA (tape feeding device). Untangling the elastic tape by reverse rotation wheel is a pre-feeding process.

Voltage, 110V(Part NO. LF290-A1) / 220V(Part NO. LF290-A2)

可自行组装 self-installation : YES

适用机型 applicable model : MODEL w/LFA



LFC-3

机械式松紧带送带装置 Mechanical Type Elastic Feeding

利用齿轮调整控制松紧带的松紧程度；压具：分3线及4线用如：P216-3, P216-4 (标准品配P216除非下单时注明)。

To Control elastic tape tension by adjusting the gear.

Presser foot:

P216-3 for 3 thread

P216-4 for 4 thread

Standard is P216. Special demand by request.

压具代号 Presser Foot	P216	P217	P218	P219
松紧带尺寸 Elastic Size	2-13mm	2-20mm	2-30mm	2-35mm

可自行组装 self-installation : YES



LS

上方带盘 Upper Tape Holder

置于上前方放布条或松紧带。

For top feeding tape or elastic.

可自行组装 self-installation : YES

适用机型 applicable model : MODEL w/LFC-3, MODEL w/TG



PS

口袋包边缝合装置 Pocket Sewing

在裤袋边缘车上包边布条，以强化缝合处并增加美观。

喇叭PS201:可用布条宽度为3/8" (9.5mm)

Overlock sewing with tape binding for strengthening the pocket edge.

PS201: Folder, for tape width 3/8" (9.5mm)

可自行组装 self-installation : YES

适用机型 applicable model : 757L-516M-3



UC

上下层防卷边 Top and Bottom Anti-Curly Edge

针对易卷曲布料所开发的气动装置，在布料进入压脚的前，将布料吹平，适用内卷，外卷等各种卷曲的情形，大幅增加车缝效率。

有三种版本可选搭：UC-LD(高级电控式)，UC-L2(经济机械式)，UC-L3(外卷单一式)。

The pneumatic device solves the problem of curly edge material. The fabric edge is flattened by air before entering the presser foot. Applicable to up-roll, down-roll, and all kinds of curly edge situations, which highly improves the sewing efficiency.

There are 3 types for this device. UC-L (High-end electronic control type), UC-L2 (economic mechanical type), and UC-L3 (Up-roll only type).

▲ 高級電控式
High-end electronic control type



▲ 機械式
Mechanical type

可自行组装 self-installation : YES
适用机型 applicable model : 700L Series

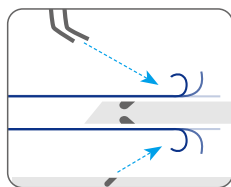

▲ 外卷模式 Up-roll :
UC-L2/UC-L3 Mechanical
& Automatic-Type

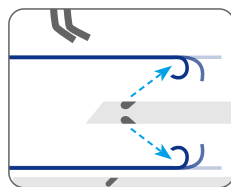

▲ 内卷模式 Down-roll :
UC-L2 Mechanical
& Automatic-Type

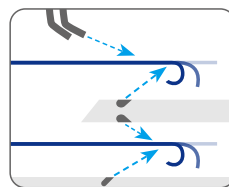

▲ 内外卷模式 Up-roll and Down-roll :
UC Automatic-Type

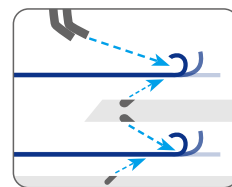

TA

双勾针环缝口袋包边缝合装置 Two Chainstitch Pocket Sewing Device

在裤袋边加包边布条并车两道环缝线，以强化缝合处增加美观。
标准喇叭(入布宽度25.4mm/出布宽度6.4mm)。

Tape binding by two chainstitch sewing for strengthening the pocket edge.
Standard folder(tape width 25.4mm/ finish width 6.4mm)

可自行组装 self-installation : YES
适用机型 applicable model : 757L-401M-8-30, 757L-401M-8-50



TBK

全沉式机头安装支撑组 Machine Body Supporter for Full Submerged Table

全沉式桌板机头支撑组。
700K series machine base for full submerged table.

可自行组装 self-installation : YES
适用桌板 applicable model : Table 700K-T2



TG

车肩带装置 Tape Guide

在车针织布时多车上一条平织布条，可防止肩部宽变型张开，压具P254J-4A布条最大宽度为13mm。

To prevent knit wear shoulder stretching, insert woven tape for strengthening.
P254J-4A: Presser foot for maximum tape width is 13 mm.

可自行组装 self-installation : YES
适用机型 applicable model : 747L-514M-3, 747L-514H-4



VT

侧吸式切线装置 Side Suction Thread Chain Cutter Device

利用吸风马达或空压机将线吸入切刀槽中予以切断(较适用于3~4线的机型)。

Take thread into trimmer tube by suction motor or air compressor. (Applicable for 3-4 thread machine)

可自行组装 self-installation : YES

适用机型 applicable model : 737L, 747L, 737KS, 747KS



**VTE
VTE-U**

侧吸式自动切线装置 (附电眼节能装置)

Side Suction Auto Thread Chain Cutter Device (with Sensor-controlled Energy-saving Device)

电控系统支持电眼节能装置, 采用电眼侦测布边, 利用控制箱调整旋钮, 控制吸风功能在切线时运作, 减少空压设备的能源消耗, 并避免缝线浪费。

Our computerized system drives sensor-controlled energy saving device.

Sensor checks the fabric edge. Turn the button of control box to set the time of air suction of chain-cutter. It saves the energy consuming of air compressor system and also saves thread consuming.

	前/中电眼 Front/middle sensors	抬压脚 Foot Lifter	气动配件Pneumatic Set	
			吸风集尘组 Suction Set	吸风线槽 Suction Channel
VTE	V	气动 Pneumatic	V	V
VTE-U	V	气动 Pneumatic	V	V

可自行组装 self-installation : NO

适用机型 applicable model : 737L, 747L, 737LQ, 747LQ



**WR/
LFC-3**

管状布条车缝装置(反条装置) Spaghetti Sewing

针织布条的拷边车缝并反条成管形, 适用于各种泳衣或睡衣、韵律服等管形肩带, 喇叭布条宽度约22.2mm (7/8"), 成型肩带直径5mm。

Overlock sewing at knit tape edge and then turn it into tube. For swimwears, night gowns etc. Folder size: tape width is 22.2mm, finished tube size is 5mm in diameter.

可自行组装 self-installation : YES

适用机型 applicable model : 737L, 747L

TUA-3X

三合一吸风集尘组 / 3-in-1 Dust Collecting Suction Device

电眼机型(ECA, ECB, CTE, VTE)标准配备的吸风集尘组, 可适用于700L、700KT/ KS/KST系列, 线屑(后吸风)、布屑(前吸风)、棉絮(内吸风)同时清除。

Standard device of sensor-controlled machine (ECA, ECB, CTE, VTE), which cleans away thread ends (rear suction), cloth waste (front suction), and lint (inner suction). Compatible to 700L, 700KT/KS/KST.

代号 Code	功能组件 Functional Section						适用机型 Applicable Series	备注 Remark	
	吸布屑方式 Vacuuming Way			抬压脚 Presser Foot Lifter	气阀 Air Switch				滤瓶 Filter
	前吸 Front	后吸 Back	切刀 Trimmer		机械式 Mechanical Type	电磁阀式* Solenoid Type			
TUA-31					单联 Single way		700K / L KS / KST / KT	700K/ Q脚踏连杆共用 The treadle rod of 700K/ Q is shared.	
TUA-31-A						●			
TUA-32K				●	双联 Double ways		700K / L / KS / KST / KT / LQ	For 700LQ SIMPLE TYPE	
TUA-33K	●	●	●			单联 Single way	●	700K	电控型号：HD-40-2-7K
TUA-34K	●	●	●	●		双联 Double ways	●		电控型号：HD-40-2-7K
TUA-32KT				●	双联 Double ways			700KT	
TUA-34KT				●		双联 Double ways	●		电控型号：HD-40-2-7K
TUA-36	不零售，700LD专用CTE,ECA,ECB,VTE,VTA (搭配电眼节能省风装置) No retail, exclusive CTE, ECA, ECB, VTE, VTA for 700LD (Allocated with the electronic eye, power-and-wind-saved device)								
TUA-37S						单联 Single way	●	700KS	电控型号： GD-40-4-7K-220
TUA-38S	●	●		●		双联 Double ways	●		电控型号： GD-40-4-7K-220 *仅适用700KS *only for 700KS
TUA-39S					单联 Single way				
TUA-40S				●	双联 Double ways				*仅适用700KS *only for 700KS
TUA-38ST	●	●		●		双联 Double ways	●	700KST	电控型号： GD-40-4-7K-220 *仅适用700KST *only for 700KST
TUA-40ST				●	双联 Double ways				*仅适用700KST *only for 700KST
TUA-41S				●		双联 Double ways	●	700KS / ESK	电控型号： i60-4-ES *仅适用700KS/ESK 接头规格 *only applicable to 700KS/ESK adapter spec
TUA-41ST	●	●		●		三联 Trigeminy	●	700KS / RSK	电控型号： i60S-4-RS *仅适用700KS/RSK 接头规格 *only for 700KST *包含电眼控制过骨机构弹开功能 *with sensor-controlled flick function for cross seam mechanism
TUC-01			●	●		三联 Trigeminy		700K / L	For ECA-U 机型用
TUC-02						单联 Single way			For ECB-U 机型用
TUC-03						三联 Trigeminy			For VTE-U 机型用
TUC-04						双联 Double ways			FOR CTE-U 机型用
TUC-05	●	●		●		双联 Double ways	●	700L	FOR VT 机型用
TUC-05-A						双联 Double ways			*抬压脚汽缸组EC413U-A *cylinder group with presser foot EC413U-A
TUC-07			●			三联 Trigeminy		700LQ	For ECA-U、VTE-U 机型用
TUC-08			●			三联 Trigeminy		700KQ	For VTE-Q 机型用
TUC-09						单联 Single way		700L	无抬压脚仅前后吸风 No presser foot lifter, only front and back vacuuming

*TUA-37S、TUA-38S、TUA-39S、TUA-40S、TUA-38ST、TUA-40ST、TUA-41S、TUA-41ST 需搭配开口型桌板(64页) Open type table required (Page.64)

*备注：电磁阀需由伺服马达的电控箱驱动，接头规格15-Pin(贺欣系列)，TSA或简易直驱系列不支持

* Remark: The solenoid must be driven by full function servo motor. The adapter spec is 15-Pin (Hohsing iseries). TSA Series and Simple type direct drive servo motor are not applicable.

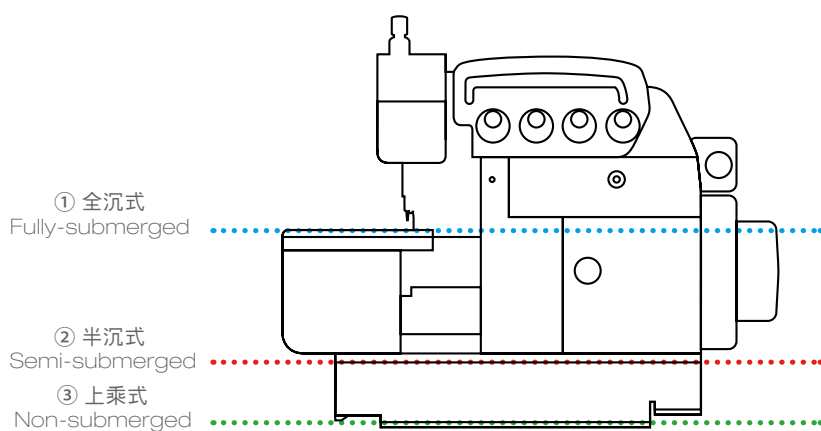

TABLE

桌板代号 Item No.	尺寸 / Size (mm)			说明 Description	适用机型 Applicable Model	备注 Remark
	长 Length	宽 Width	厚 Thickness			
700K-T	1200	540	40	② 半沉式 Semi-submerged	700L, 700KT 一般车 700L, 700KT Standard Model	
700K-T2	1200	540	40	① 全沉式 Fully-submerged	700L 一般车 700L Standard Model	需搭配 TB201 TB201 set required
700K-T3	1200	540	40	① 全沉式 Fully-submerged	700L/EC, CT, VT	需搭配 TB201 TB201 set required
700K-T4	1200	540	40	② 半沉式 Semi-submerged	700L/BKF1	
700LD-T	1200	540	40	② 半沉式 Semi-submerged	700KT, 700L 直驱车 700KT, 700L DD Motor Model	
700LD-T1	1200	540	40	② 半沉式 Semi-submerged	700LD/UC	
700KS-T	1200	540	40	② 半沉式 Semi-submerged	700KS, 700KST	
700KS-T2	1200	540	40	② 半沉式 Semi-submerged	700KS, 700KST 直驱车 700KS, 700KST DD Motor Model	
700KS-T1	1200	540	40	② 半沉式 Semi-submerged	700KS, 700KST	开口型 Open type
700KS-T3	1200	540	40	② 半沉式 Semi-submerged	700KS, 700KST 直驱车 700KS, 700KST DD Motor Model	开口型 Open type
700KS-T4	1200	540	40	② 半沉式 Semi-submerged	700KS, 700KST	开口型搭 KX10E-A布漏组 Open type with KX10E-A cloth slide
700KS-T5	1200	590	40	③ 上乘式 Non-submerged	700KS/LFD	开口型, 搭SM899-A Open type with SM899-A

INTERLOCK SEWING MACHINE

High Speed Interlock Sewing Machine

C007 L - W 12 2 - 3 56 / CQ

②系列 Series

- L 高速型
Ultra High Speed
- LX 微油型
Semi-Dry
- KP K型进阶款
K Plus
- K 基本款
Basic Type
- KD 基本款配直驱马达
K Type with DD Motor

①机种别 Model

- C 筒型
Cylinder Bed
- F 平台型
Flat Bed
- S 小筒型
Small Cylinder Bed
- U 超小筒
Ultra Small Cylinder Bed

③网线方式 Covering Types

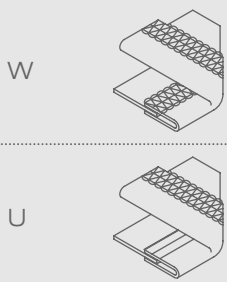

④功能 Function

- 12 一般平缝
General Plain Seaming
- 13 拷下摆
Bottom Hemming
- 15 罗纹裤头松紧带包缝
Tubular Rib-Fabric Elastic Waistband Attaching
- 16 一般厚布料的平缝
General Plain Seaming for Heavy Material
- 22 滚边车缝
Tape Binding
- 32 拷克骨车缝
Overlock-Seam Covering
- 52 松紧带附右切刀
Elastic Tape Attaching with Right Side Fabric Trimmer
- 53 环型松紧带车缝
Tubular Elastic Waistband Attaching
- 54 松紧带折缝
Elastic Hemming
- 61 裤耳车缝
Belt Loop Seaming
- 71 双勾针结构
Double-Looper Mechanism
- 72 三勾针结构
Triple-Looper Mechanism
- 81 左切刀修布装置
Left Side Fabric Trimmer
- 82 松紧带上带边缝附左切刀
Elastic Tape Insertion with Left Side Fabric Trimmer
- 92 四针六线搭接缝
Four-Needle Flat Seaming

⑥针数 Needle Numbers

Needle Numbers

⑧配件 Device

⑦	No.	mm	inch
	32	3.2	1/8
	40	4.0	5/32
	48	4.8	3/16
	56	5.6	7/32
	64	6.4	1/4

⑤针板舌片 Needle Plate Finger

Needle Plate Finger

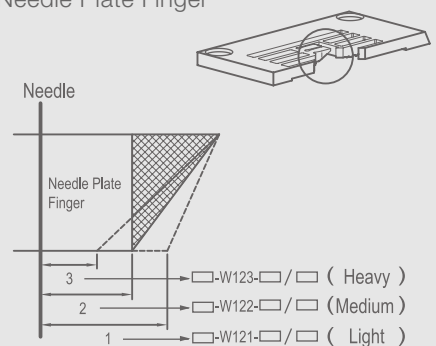

- 1 = 薄布料/细结线(密针)
Light Material/Short Stitch Length
- 2 = 中厚布料/中结线(一般针)
Medium Material/Common Stitch Length
- 3 = 厚布料/粗结线(粗针)
Heavy Material/Long Stitch Length

- ⑨DCL □□ C007L/LX型直驱电机组
Direct Drive Servo Motor for C007L/LX
- ⑨DCK □□ C007KP型直驱电机组
Direct Drive Servo Motor for C007KP
- ⑨DFK □□ F007KD型直驱电机组
Direct Drive Servo Motor for F007KD
- ⑨DSK □□ S007KD型直驱电机组
Direct Drive Servo Motor for S007KD
- ⑨DUK □□ U007型直驱电机组
Direct Drive Servo Motor for U007

INTERLOCK DD SERVO MOTOR

C007KP-W162-364 / CH / DCK□□

* 马达介绍, 详细请参考P.114
Direct drive, please refer to P.114

登峰

Ascend to Greatness

造極

C007LX



C007L SERIES

C007L

超高速筒型绷缝机

Ultra High Speed Cylinder Bed
Interlock Sewing Machine

C007LX

微油超高速筒型绷缝机

Semi-Dry Ultra High Speed Cylinder
Bed Interlock Sewing Machine

C007L/LX SERIES

FEATURES

结合SiRUBA高科技技术的旗舰機種
Flagship model with SiRUBA's state-of-the-art innovation.



内缩式床台

缝制物更靠近针孔，车缝定位准确，车缝时更加顺畅就手。

The Recessed Machine Bed

With the recessed machine bed, sewing material comes closer to the needle hole, thus provides more precise easier, and smoother sewing.



短筒座的设计

操作性能优越，可应用于广泛的饰盖缝纫工程，增加延伸盖就可以车缝包边或包带的缝纫工程。

Recessed Cylinder Bed

The recessed cylinder bed on the front cover is shortened. The short cylinder has superior operating performance, which can be applied to the extensive covering seam. Hemming or wrapping can be sewed just by increasing the extended cover.



针棒与勾针的新油封结构

新的油封设计强化了机构的油附着力，减少了润滑油甩出。此外，高耐磨材料显著提高性能及耐久性。

New Oil Sealing Technology

New oil sealing structure used on needle bar and looper mechanism can efficiently avoid oil splash. New wear-resistant material also enhances performance and durability.

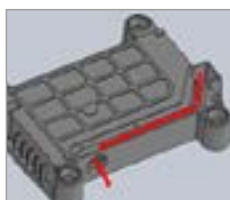

新型散热结构同时降低振动

全新散热设计提供更佳的降温效果。更稳固的防震结构，提升机械的安定与精度，车缝体验更为顺畅。

New Cool Down Technology

Frame structure renewed with better cooling mechanism. Vibration is also reduced to contribute better sewing experience.



直感式的差动送具调整

差动送具的调整机构设计在缝纫机本体的右后方，于车缝时使用右手直感操作，准确无误。

Easy-to-adjust Differential Feed Dog Design

The differential feed dog adjuster is placed at right side of the operator. Adjust it easily without hesitation.



新设计上夹线装置
出刀迅速准确，夹线稳定。

New-Designed Upper Thread Gripper
The new-designed upper thread gripper provides fast, precise movement and grips thread stably.

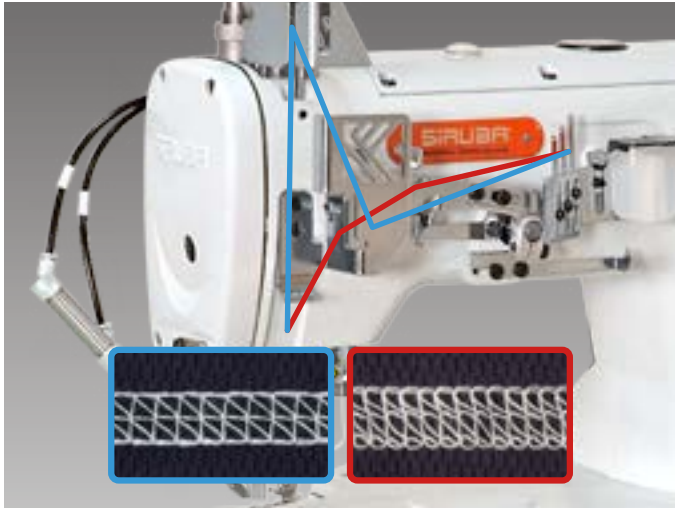

双天秤挑线控线组
全新双天秤挑线控线组的设计，缝制厚、薄布料皆适用，车缝适用范围更广，适用性更高。

Dual Thread Take-up Mechanism
The brand new design of dual thread take-up lever thread tension combination is ideal for both heavy and light fabric. Sewing applicable range is wider and the applicability is higher.

— 中厚布料 (Medium heavy fabric)
— 薄布料 (Light fabric)

CO07LX series

无油无虑 Oilless

SiRUBA 的三针车提供您畅快的缝制体验
C007LX provides you all new sewing experience.



针棒采用特殊的表面处理，缝制时无油污渍，显著提高缝制品质，减少重工与缝制品脏污。
针棒润滑机构再进化，增加零件耐久度。

Needle bar mechanism re-designed with new surface treatment, no oil stains and oil splash during operating, greatly increase sewing quality. Needle bar also has better durability due to new lubrication mechanism.

规格
SPECIFICATIONS
C007LX - W122 - 240 /CH/DCLU

规格索引, 详细请参考P.65 Specification index, please refer to P.65

- | | | | |
|-----------------------|----------------------------|-------------------|-------------|
| ① 机种别 Model | ④ 功能 Function | ⑦ 针距 Needle gauge | ⑨ 马达 Motor |
| ② 系列 Series | ⑤ 针板舌片 Needle Plate Finger | ⑧ 配件 Device | U: U Series |
| ③ 网线方式 Covering Types | ⑥ 针数 Needle Numbers | | H: H Series |

C007L/C007LX Device		⑤	⑥	⑦	⑧	⑨	⑩	⑪	⑫	⑬	⑭
		mm	mm	mm	mm	mm	mm	mm	mm	mm	S.P.M. (Max)
一般平缝 / 下摆车缝 General Seaming/ Bottom Hemming	C007L-W12 ⑤ -2 ⑦ /CH	1,2	2	4	3.2/ 4.0/ 4.8	1.4~3.6	0.9~1.4	5/7	H / U	6000	
	C007L-W12 ⑤ -3 ⑦ /CH	1,2	3	5	4.8/ 5.6/ 6.4	1.4~3.6	0.9~1.4	5/7	H / U	6000	
	C007L-U12 ⑤ -2 ⑦ /CH	1,2	2	3	3.2/ 4.0/ 4.8	1.4~3.6	0.9~1.4	5/7	H / U	6000	
	C007L-U12 ⑤ -3 ⑦ /CH	1,2	3	4	4.8/ 5.6/ 6.4	1.4~3.6	0.9~1.4	5/7	H / U	6000	
	C007L-W12 ⑤ -2 ⑦ /RH/RCH-3M	1,2	2	4	4.0/ 4.8	1.4~3.6	0.9~1.4	5/7	H / U	6000	
	C007L-W12 ⑤ -3 ⑦ /RH/RCH-3M	1,2	3	5	5.6/ 6.4	1.4~3.6	0.9~1.4	5/7	H / U	6000	
	C007L-U12 ⑤ -2 ⑦ /RH/RCH-3M	1,2	2	3	4.0/ 4.8	1.4~3.6	0.9~1.4	5/7	H / U	6000	
	C007L-U12 ⑤ -3 ⑦ /RH/RCH-3M	1,2	3	4	5.6/ 6.4	1.4~3.6	0.9~1.4	5/7	H / U	6000	
	C007L-W162-2 ⑦ /CH	2	2	4	4.0/ 4.8	1.4~3.6	0.9~1.4	5/7	H / U	6000	
	C007L-W162-3 ⑦ /CH	2	3	5	5.6/ 6.4	1.4~3.6	0.9~1.4	5/7	H / U	6000	
选购配件 : UTP, UTQ, UTR, UTS, CLA, CMR, CAR/UTP, CAR/UTQ Optional Device: UTP, UTQ, UTR, UTS, CLA, CMR, CAR/UTP, CAR/UTQ											
罗纹裤头松紧带包缝 Tubular Rib-Fabric Elastic Waistband Attaching	C007L-W152-3 ⑦ /CZ/RLQ/(⑨)	2	3	5	5.6/ 6.4	1.4~3.6	0.3~2.9	5	H / U	6000	
	选购配件 : UTP, UTQ, CL*, CMR, CAR/UTP, CAR/UTQ Optional Device: UTP, UTQ, CL*, CMR, CAR/UTP, CAR/UTQ * 建议采用 CL 后拉轮, 以提高车缝稳定性 *CL rear puller is recommended to improve sewing stability.										
拷克倒骨盖缝 Overlock-seam Covering Stitch	C007L-W322-3 ⑦ /CC	2	3	5	5.6/ 6.4	1.4~3.6	0.9~1.4	5/7	H / U	6000	
	C007L-U322-3 ⑦ /CC	2	3	4	5.6/ 6.4	1.4~3.6	0.9~1.4	5/7	H / U	6000	
	C007L-W322-3 ⑦ /CE	2	3	5	5.6/ 6.4	1.4~3.6	0.9~1.4	5/7	H / U	6000	
	C007L-U322-3 ⑦ /CE	2	3	4	5.6/ 6.4	1.4~3.6	0.9~1.4	5/7	H / U	6000	
选购配件 : UTP, UTQ, UTR, UTS, CLA, CMR, CAR/UTP, CAR/UTQ Optional Device: UTP, UTQ, UTR, UTS, CLA, CMR, CAR/UTP, CAR/UTQ											
环型松紧带裤头接缝 Tubular Jacquard Elastic Waistband Attaching	C007L-W532-232/CR/UTP/CL/CX/RLP1	2	2	4	3.2	1.4~3.6	0.9~1.4	5/7	H / U	5000	
	C007L-W532-3 ⑦ /CR/UTP/CL/CX/RLP	2	3	5	5.6/ 6.4	1.4~3.6	0.9~1.4	5/7	H / U	5000	
	C007L-U532-232/CR/UTP/CL/CX/RLP1	2	2	3	3.2	1.4~3.6	0.9~1.4	5/7	H / U	5000	
	C007L-U532-3 ⑦ /CR/UTP/CL/CX/RLP	2	3	4	5.6/ 6.4	1.4~3.6	0.9~1.4	5/7	H / U	5000	
松紧带折缝 Elastic Hemming	C007L-W542-2 ⑦ /CFC	2	2	4	4.0/ 4.8	1.4~3.6	0.3~2.9	5/7	H / U	3500	
	C007L-W542-3 ⑦ /CFC	2	3	5	5.6/ 6.4	1.4~3.6	0.3~2.9	5/7	H / U	3500	
	选购配件 : FH, CL* Optional Device: FH, CL* * 建议采用 CL 后拉轮, 以提高车缝稳定性 *CL rear puller is recommended to improve sewing stability.										

规格

SPECIFICATIONS

C007LX - W122 - 240 /CH/DCLU

规格索引, 详细请参考P.65 Specification index, please refer to P.65

- ① 机种别 Model
- ② 系列 Series
- ③ 网线方式 Covering Types
- ④ 功能 Function
- ⑤ 针板舌片 Needle Plate Finger
- ⑥ 针数 Needle Numbers
- ⑦ 针距 Needle gauge
- ⑧ 配件 Device
- ⑨ 马达 Motor
U: U Series
H: H Series

C007L/C007LX		⑤	⑥		mm	mm		mm	⑧	⑨	S.P.M. (Max)
左切刀修布下摆车缝 Bottom Hemming with Left Side Fabric Trimmer	C007L-W81 ⑤ -2 ⑦ /CRL	1,2,3	2	4	4.0/ 4.8	1.4~3.6	0.9~1.4	5/7	H / U	5000	
	C007L-W81 ⑤ -3 ⑦ /CRL	1,2,3	3	5	5.6/ 6.4	1.4~3.6	0.9~1.4	5/7	H / U	5000	
	C007L-U81 ⑤ -2 ⑦ /CRL	1,2,3	2	3	4.0/ 4.8	1.4~3.6	0.9~1.4	5/7	H / U	5000	
	C007L-U81 ⑤ -3 ⑦ /CRL	1,2,3	3	4	5.6/ 6.4	1.4~3.6	0.9~1.4	5/7	H / U	5000	
	C007L-W81 ⑤ A-2 ⑦ /CRL	1,2,3	2	4	4.0/ 4.8	1.4~3.6	0.9~1.4	5/7	H / U	5000	
	C007L-W81 ⑤ A-3 ⑦ /CRL	1,2,3	3	5	5.6/ 6.4	1.4~3.6	0.9~1.4	5/7	H / U	5000	
	C007L-U81 ⑤ A-2 ⑦ /CRL	1,2,3	2	3	4.0/ 4.8	1.4~3.6	0.9~1.4	5/7	H / U	5000	
	C007L-U81 ⑤ A-3 ⑦ /CRL	1,2,3	3	4	5.6/ 6.4	1.4~3.6	0.9~1.4	5/7	H / U	5000	
选购配件 : UTP, UTQ, UTR, CMR, CAR/UTP, CAR/UTQ, CL/UTP Optional Device: UTP, UTQ, UTR, CMR, CAR/UTP, CAR/UTQ, CL/UTP											
松紧带上带边缝 附左切刀 Elastic Attaching with Left Fabric Trimmer	C007L-W82 ⑤ -2 ⑦ /CRL/CHP/CL/RL	1,2,3	2	4	4.0/ 4.8	1.4~3.6	0.9~1.4	5/7	H / U	5000	
	C007L-W82 ⑤ -3 ⑦ /CRL/CHP/CL/RL	1,2,3	3	5	5.6/ 6.4	1.4~3.6	0.9~1.4	5/7	H / U	5000	
	C007L-U82 ⑤ -2 ⑦ /CRL/CHP/CL/RL	1,2,3	2	3	4.0/ 4.8	1.4~3.6	0.9~1.4	5/7	H / U	5000	
	C007L-U82 ⑤ -3 ⑦ /CRL/CHP/CL/RL	1,2,3	3	4	5.6/ 6.4	1.4~3.6	0.9~1.4	5/7	H / U	5000	
	C007L-W82 ⑤ A-2 ⑦ /CRL/CHP/CL/RL	1,2,3	2	4	4.0/ 4.8	1.4~3.6	0.9~1.4	5/7	H / U	5000	
	C007L-W82 ⑤ A-3 ⑦ /CRL/CHP/CL/RL	1,2,3	3	5	5.6/ 6.4	1.4~3.6	0.9~1.4	5/7	H / U	5000	
	C007L-U82 ⑤ A-2 ⑦ /CRL/CHP/CL/RL	1,2,3	2	4	4.0/ 4.8	1.4~3.6	0.9~1.4	5/7	H / U	5000	
	C007L-U82 ⑤ A-3 ⑦ /CRL/CHP/CL/RL	1,2,3	3	5	5.6/ 6.4	1.4~3.6	0.9~1.4	5/7	H / U	5000	
选购配件 : UTP, UTQ, CMR, CAR/UTQ, CL/UTP Optional Device: UTP, UTQ, CMR, CAR/UTQ, CL/UTP											

RH

弧型筒式 超高速绷缝机

Ultra High Speed Cylinder
Bed Interlock Sewing Machine



内缩式床台

缝制物更靠近针孔，车缝定位准确，车缝时更加顺畅就手。

The Recessed Machine Bed

With the recessed machine bed, sewing material comes closer to the needle hole, thus provides more precise easier, and smoother sewing.



弧型短筒座的设计

改良传统式绷缝机的棱角筒座，RH的弧型设计让送料的缝制过程更顺畅，且使操作时的取、放更为省力，可应用于广泛的饰盖缝纫工程，增加延伸盖就可以车缝边或包带的缝纫工程。

Shortened cylinder bed with arc shape design

Improved from traditional interlock Sewing machine, this new RH arc design leads to a more easier sewing process. It is also applicable for covering seam and for tape binding with extended cover.



直觉式操作

RH弧型筒式绷缝机，直觉式放入布料，有效降低因人工疲劳操作所造成的不良率、提升生产效率，更适用于T恤圆领等缝制工艺。

More user-friendly operation

This new design makes fabric feeding more user-friendly and makes sewing process more easier and increases productivity. It is the best option for sewing T-Shirt's ribbed collar.



RCH-3M [三合一] 一般平缝 / 下摆车缝 / 拷克倒骨盖缝

三合一模式平缝、折下摆、倒骨，更换方便，多样化功能，高效率、低成本。

RCH-3M [3 in 1] : GENERAL SEAMING/BOTTOM HEMMING/COVERING STITCH (Fold-down type)

3-in-1 model for multifunctional and efficient production with lower cost.



C007L_W122_356_RH_DCLH1_1

C007KP SERIES FEATURES



内缩式床台

缝制物更靠近针孔，车缝定位准确，车缝时更加顺畅就手。

The Recessed Machine Bed

With the recessed machine bed, sewing material comes closer to the needle hole, thus provides more precise easier, and smoother sewing.



新设计上下切刀组

新设计气、电动上下切刀组，出刀稳定准确，切线利落，调整容易。

New-Designed Top and Under Trimmer

The new-designed pneumatic, electric top & under knife combination have fast, stable and precise. Trims thread neatly. Handy operation, easy to adjust.



针棒与勾针的新油封结构

新的油封设计强化了机构的油附着力，减少了润滑油甩出。同时使用高耐磨材料，显著提高性能及耐久性。

New Oil Sealing Technology

New oil sealing structure used on needle bar and looper mechanism can efficiently avoid oil splash. New wear-resistant material also enhances performance and durability.



短筒座的设计

操作性能优越，可应用于广泛的饰盖缝纫工程，增加延伸盖就可以车缝包边或包带的缝纫工程。

Recessed Cylinder Bed

The recessed cylinder bed on the front cover is shortened. The short cylinder has superior operating performance, which can be applied to the extensive covering seam. Hemming or wrapping can be sewed just by increasing the extended cover.

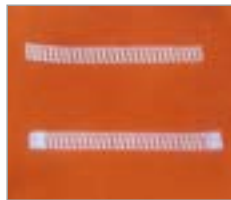

密缝装置

通过缩短送具行程，在车缝起始或结束进行密缝的功能，确保缝线不易脱落，提高车缝品质，基本车为脚踏板控制，电动和气动控制为选配。

Condense Stitching Device

By reducing the strokes of feed dog, at the beginning and the end of sewing, condense stitching reinforces the stitches. This enhances the sewing sturdiness and quality. Basic model is controlled by pedal. Electric and pneumatic controls are optional.



新设计上夹线装置

出刀迅速准确，夹线稳定。

Brand New Design Upper Thread Gripper

The newly designed upper thread gripper provides fast, precise movement and stable thread gripper.



送具并列式调整钮设计

[专利] 前送齿及后送齿，通过全新并列式调整钮设计，可独自调整同步或正逆差动，指标刻度方便使用者进行准确调整前后送齿，大大提升操作者使用上的便利性。

Front and Rear Feed Dog Minute Adjustment

[Patent] Synchronization or forward / reverse differential of front and rear feed dog can be finely adjusted alone by the brand new parallel adjustable feed dog control knobs. Furthermore, the indicator scales is easy for user to adjust the feeding precisely, which improves ease of operation greatly.

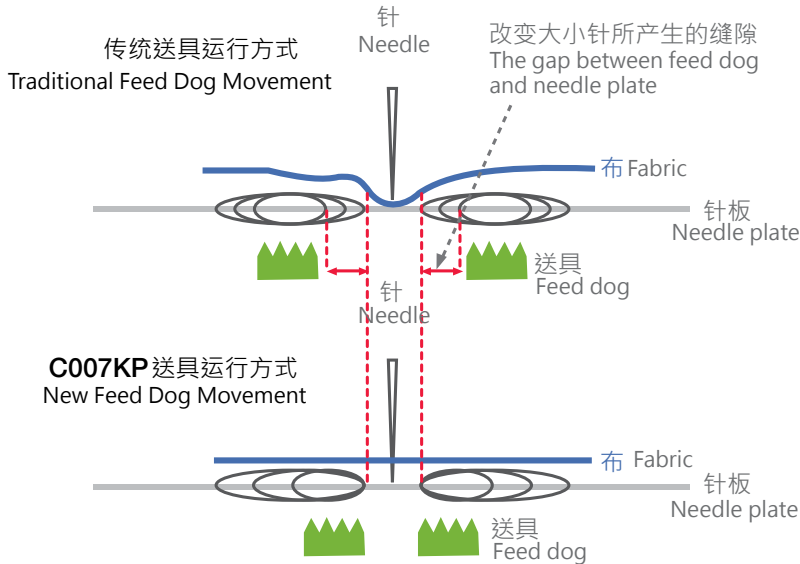

全新移动送齿的传动设计

[专利] 后、前送齿依据椭圆式运动方式，统一由针孔向外运动延伸，缝制物可获得准确稳定送布，也不会因为过骨或差动而前、后送齿产生间隙，影响车缝品质。

Brand New Differential Feed Dog Driving Design

[Patent] The front and rear feed dog move elliptically, and centrally, a direct extension from needle hole, thus enable sewing material to get precise and stable feeding. Therefore, the sewing quality will not be affected by the clearance between front and rear feed dog which is resulted from the cross seam or differential action.

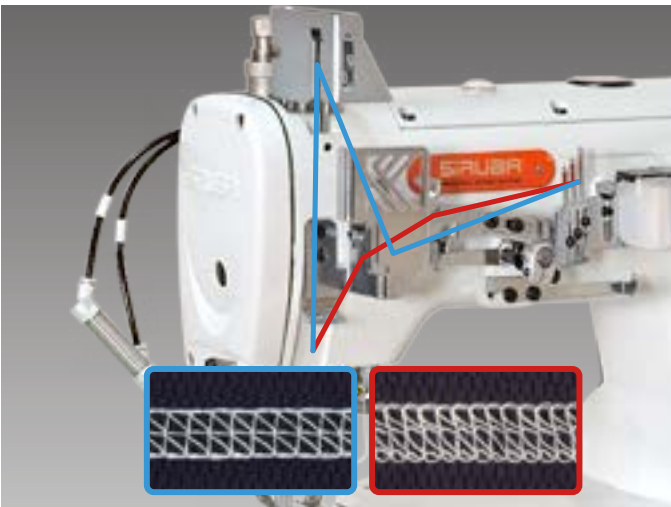

双天秤挑线控线组

全新双天秤挑线控线组的设计，缝制厚、薄布料皆适用，车缝适用范围更广，适用性更高。

Dual Thread Take-up Mechanism

The brand new design of dual thread take-up lever thread tension combination is ideal for both heavy and light fabric. Sewing applicable range is wider and the applicability is higher.

- 中厚布料 (Medium heavy fabric)
- 薄布料 (Light fabric)

规格

SPECIFICATIONS

C007KP - W122 - 2 40 /CH/DCKU

规格索引, 详细请参考P.65 Specification index, please refer to P.65

- ① 机种别 Model
- ② 系列 Series
- ③ 网线方式 Covering Types
- ④ 功能 Function
- ⑤ 针板舌片 Needle Plate Finger
- ⑥ 针数 Needle Numbers
- ⑦ 针距 Needle gauge
- ⑧ 配件 Device
- ⑨ 马达 Motor
U: U Series
H: H Series

C1 Device



Model	⑥	④	⑦	⑧	⑨	S.P.M. (Max)		
C007KP-W122-⑥⑦/CH/(⑨)	2	4	3.2/ 4.0/ 4.8	1.4 ~ 3.6	0.3 ~ 2.9	5/7	H / U	6000
	3	5	4.8/ 5.6/ 6.4	1.4 ~ 3.6	0.3 ~ 2.9	5/7	H / U	6000
C007KP-W162-⑥⑦/CH/(⑨)	2	4	4.0/ 4.8	1.4 ~ 3.6	0.3 ~ 2.9	5/7	H / U	6000
	3	5	4.8/ 5.6/ 6.4	1.4 ~ 3.6	0.3 ~ 2.9	5/7	H / U	6000
C007KP-W122-⑥⑦/CH-4M/(⑨)	3	5	5.6/ 6.4	1.4 ~ 3.6	0.3 ~ 2.9	5/7	H / U	6000



C007KP-W122-356/CH/UTP

一般平缝 / 下摆车

本机型为双面饰绷缝筒车的基本机型, 可装配附件进行多种功能车缝例如: 内衣裤、运动衫接缝及下摆车缝(附可调式下摆车缝组)。

GENERAL SEAMING / BOTTOM HEMMING

Basic model of interlock Sewing machine with double side cover-stitching. It is available for various sewing by optional devices. Such as plain seaming and bottom hemming for underwears, sportswears, etc... (equipped with adjustable hemming set)

W122 : 薄中厚多功能对应针板

W162 : 高行程

W122 : Light / Medium / Heavy Material Multi-function

W162 : High needle bar stroke

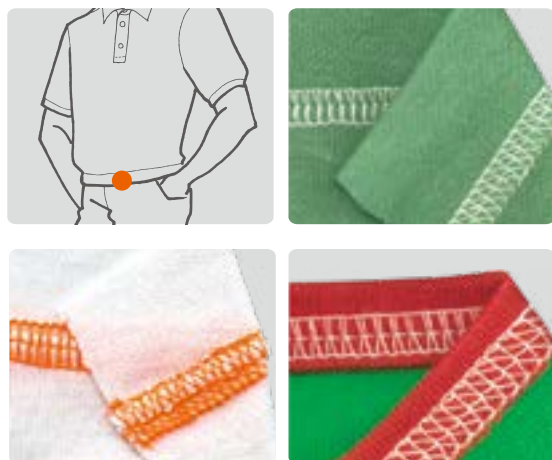

CH-4M [四合一]

一般平缝 / 下摆车缝 / 拷克倒骨盖缝 / 上带滚边车缝

平缝、折下摆、倒骨、上带滚边四合一模式, 更换方便, 多样化功能, 高效率、低成本。

CH-4M [4 in 1]

GENERAL SEAMING / BOTTOM HEMMING / COVERING (Fold-down Type) / TAPE BINDING.

4-in-1 model for multifunctional and efficient production with lower cost.

选购配件 OPTIONAL DEVICE

UTP, UTQ, UTR, UTS, CLA, CMR, CAR/UTP, CAR/UTQ

规格

SPECIFICATIONS

C007KP - W81 2 A - 2 32/ CRL / DCKU

规格索引, 详细请参考P.65 Specification index, please refer to P.65

- ① 机种别 Model
- ② 系列 Series
- ③ 网线方式 Covering Types
- ④ 功能 Function
- ⑤ 针板舌片 Needle Plate Finger
- ⑥ 针数 Needle Numbers
- ⑦ 针距 Needle gauge
- ⑧ 配件 Device
- ⑨ 马达 Motor
U: U Series
H: H Series

C2 Device



C007KP-W812A-⑥⑦/CRL/(⑨)	2	4	3.2/ 4.0/ 4.8	1.4 ~ 3.6	0.3 ~ 2.9	5/7	H / U	4500
	3	5	5.6/ 6.4	1.4 ~ 3.6	0.3 ~ 2.9	5	H / U	4500



C007KP-W812-356/
CRL

左切刀下摆车缝

附左切刀修齐布边后, 再进行下摆车缝工程, 适用于车缝T恤、汗衫的下摆等。

BOTTOM HEMMING WITH LEFT SIDE FABRIC TRIMMER

Left hand side fabric trimming before hemming. For sleeve opening and bottom of underwears, T-shirt, or sportswears, etc...



适用规格
APPLICABLE SPEC.

W812, U812

* 薄布料建议选购 W811
Recommended for thin fabrics



选购配件 OPTIONAL DEVICE

UTP, UTQ, UTR, CL, CMR, CAR/UTP, CAR/UTQ

C3 Device



C007KP-W222-⑥⑦/CQ/(⑨)	2	4	4.0/ 4.8	1.4 ~ 3.6	0.3 ~ 2.9	5/7	H / U	6000
	3	5	5.6/ 6.4	1.4 ~ 3.6	0.3 ~ 2.9	5/7	H / U	6000
C007KP-W222-⑥⑦/CQA/(⑨)	3	5	5.6	1.4 ~ 3.6	0.3 ~ 2.9	5/7	H / U	5000



C007KP-W222-356/CQ

CQ:上带滚边车缝

适用于内衣裤、T恤的领口、裤管口等上带滚边的车缝工程。

注: 滚边器尺寸为入布端宽1-3/8", 出布时折成三折, 出口端成品宽为1/2"。

CQ:TAPE BINDING

For tape binding on openings of leg or neck of underwears, T-shirts, etc...

Remark: Binder's opening size is 1-3/8" wide and finished size is 1/2" wide in three folds.

选购配件 OPTIONAL DEVICE

CLA, FA

规格

SPECIFICATIONS

C007KP - W322 - 3 56 /CC/DCKU

规格索引, 详细请参考P.65 Specification index, please refer to P.65

- ① 机种别 Model
- ② 系列 Series
- ③ 网线方式 Covering Types
- ④ 功能 Function
- ⑤ 针板舌片 Needle Plate Finger
- ⑥ 针数 Needle Numbers
- ⑦ 针距 Needle gauge
- ⑧ 配件 Device
- ⑨ 马达 Motor
U: U Series
H: H Series

C4 Device

	⑥	⑤	⑦	④	③	②	①	⑨
C007KP-W322-3⑦/CC/(⑨)	3	5	5.6/6.4	1.4 ~ 3.6	0.3 ~ 2.9	5	H / U	6000
C007KP-W322A-3⑦/CC/(⑨)	3	5	5.6/6.4	1.4 ~ 3.6	0.3 ~ 2.9	5	H / U	6000
C007KP-W322-3⑦/CE/(⑨)	3	5	5.6/6.4	1.4 ~ 3.6	0.3 ~ 2.9	5	H / U	6000

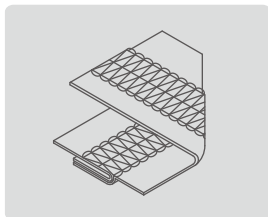

CC

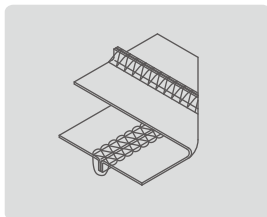

CE



CC

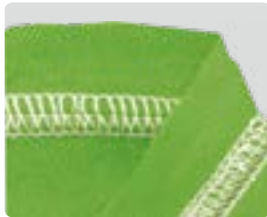

CE

拷克倒骨盖缝

CC 倒骨型: 适用于4线包缝的盖缝。

W322A为两用型, 针板与送具改用W122规格, 并附CH组。

CE 立骨型: 适用于3线包缝的盖缝。

配件盒另附有CC倒骨规格的牛角 (导布片)。

OVERLOCK-SEAM COVERING STITCH

CC Fold-down type: For 4-thread overlock-seam covering stitch
W322A is dual-purpose specification, which is with W122's needle plate, feed dog and CH set.

CE Flattening type: For 3-thread overlock-seam covering stitch, and an extra guide of overlock-seam (CC specification, fold-down type) is included in the accessory box.

选购配件 OPTIONAL DEVICE

UTP, UTQ, UTR, UTS, CLA, CMR, CAR/UTP, CAR/UTQ

C5 Device

	⑥	⑤	⑦	④	③	②	①	⑨
C007KP-W922-4⑦/CW/(⑨)	4	6	5.6/6.0/6.4	1.4 ~ 3.6	0.3 ~ 2.9	5	H / U	6000



CW

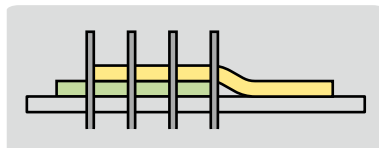

四针六线搭接缝

适用于一般内衣裤二片布接缝处的接缝和补强, 附有专属的导边器, 可使二片布顺畅缝合。

FOUR-NEEDLE FLAT SEAMING

For flat seaming 2 pieces of fabric. Equipped with fabric guide for easy operation.

选购配件 OPTIONAL DEVICE

UTQ, UTS, CL, CMR, CAR/UTQ

规格

SPECIFICATIONS

C007KP - W522 - 2 40 /CR /FE

规格索引, 详细请参考P.65 Specification index, please refer to P.65

- ① 机种别 Model ④ 功能 Function ⑦ 针距 Needle gauge
- ② 系列 Series ⑤ 针板舌片 Needle Plate Finger ⑧ 配件 Device
- ③ 网线方式 Covering Types ⑥ 针数 Needle Numbers

C6 Device



C007KP-W522-⑥⑦/CR/FE	2	4	3.2/ 4.0/ 4.8	1.4 ~ 3.6	0.3 ~ 2.9	5	4500
	3	5	4.8/ 5.6/ 6.4	1.4 ~ 3.6	0.3 ~ 2.9	5	4500
C007KP-W522-⑥⑦/CR/FFC	2	4	3.2/ 4.0/ 4.8	1.4 ~ 3.6	0.3 ~ 2.9	5	4500
	3	5	4.8/ 5.6/ 6.4	1.4 ~ 3.6	0.3 ~ 2.9	5	4500
C007KP-W522-⑥⑦/CR/SMK	2	4	3.2/ 4.0/ 4.8	1.4 ~ 3.6	0.3 ~ 2.9	5	4500
	3	5	4.8/ 5.6/ 6.4	1.4 ~ 3.6	0.3 ~ 2.9	5	4500
C007KP-W522-⑥⑦/CR/STC	2	4	3.2/ 4.0/ 4.8	1.4 ~ 3.6	0.3 ~ 2.9	5	4500
	3	5	4.8/ 5.6/ 6.4	1.4 ~ 3.6	0.3 ~ 2.9	5	4500



C007KP-W522-356/CR/FE



C007KP-W522-356/CR/FFC

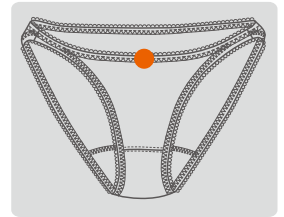
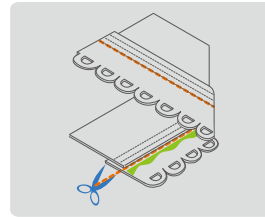

松紧带 / 蕾丝松紧带上带车缝附右切刀

经由上送带装置, 控制长度与张力, 附右切刀修布装置, 能于车缝前将布修齐, 更能提高车缝品质, 如女用内衣裤的松紧带或蕾丝松紧带车缝。

FFC: 机械式送带

FE: 简易电子式送带

SMK: 电子计数式送带

SMK1-C-01 附定位器, 适合简易伺服或离合器马达

SMK1-C-02 以中继线, 连接伺服马达

STC: 张力控制式送带

STC1-U-01 附定位器, 适合简易伺服或离合器马达

STC1-U-02 以中继线, 连接伺服马达

选购配件 OPTIONAL DEVICE

CL, LF-A, LS-A, CSA, CSB

ELASTIC / LACE ATTACHING WITH RIGHT SIDE FABRIC TRIMMER

Top feeding devices ensure even length and tension controlled by electric digital controller, with right side fabric trimmer for elastic or lace attaching smoothly and properly on women's underwears.

FFC: Mechanic type tape feeding.

FE: Simple electric type tape feeding.

SMK: Electric metering type tape feeding

SMK1-C-01 with synchronizer for simple servo motor or clutch motor

SMK1-C-02 Connected to servo motor by encoder cable.

STC: Tension sensor type tape feeding

STC1-U-01 with synchronizer for simple servo motor or clutch motor

STC1-U-02 Connected to servo motor by encoder cable.

规格

SPECIFICATIONS

C007KP-W532-240/CR/CX/UTP/RLP/DCKU

规格索引, 详细请参考P.65 Specification index, please refer to P.65

- ① 機種別 Model
 - ② 系列 Series
 - ③ 網線方式 Covering Types
 - ④ 功能 Function
 - ⑤ 針板舌片 Needle Plate Finger
 - ⑥ 針數 Needle Numbers
 - ⑦ 針距 Needle gauge
 - ⑧ 配件 Device
 - ⑨ 馬達 Motor
U : U Series
H : H Series
- *UTP 請參考 Please refer to P.113

C7 Device



C007KP-W532-⑥⑦/CR/CX/UTP/RLP1/(⑨) *1	2	4	3.2/ 4.0/ 4.8	1.4 ~ 3.6	0.3 ~ 2.9	5	H / U	4500
	3	5	4.8/ 5.6/ 6.4	1.4 ~ 3.6	0.3 ~ 2.9	5	H / U	4500
C007KP-W532-⑥⑦/CR/CX/UTR/RLP1/(⑨) *2	2	4	3.2/ 4.0/ 4.8	1.4 ~ 3.6	0.3 ~ 2.9	5	H / U	4500
	3	5	4.8/ 5.6/ 6.4	1.4 ~ 3.6	0.3 ~ 2.9	5	H / U	4500



环型松紧带裤头接缝附右切刀

将环型平织松紧带与衣物接缝适用于男女内裤裤腰的松紧带缝合, 配合右切刀修布装置, 更能提高缝制品质。

- *1: 气动切线, 含气动式吸屑组
- *2: 电动切线, 需另外搭配吸风马达 (CSA或CSB)

TUBULAR JACQUARD ELASTIC WAISTBAND ATTACHING WITH RIGHT SIDE FABRIC TRIMMER

For tubular elastic or lace waistband attaching on men's or women's brief, with right hand side fabric trimmer to increase sewing quality and efficiency.

C007KP-W532-356/CR/CX/CL/UTP

- *1: Pneumatic thread chain cutter, including fabric waste suction set
- *2: Electric thread chain cutter, an optional suction motor (CSA or CSB) is required.

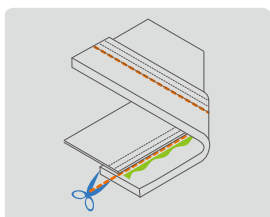
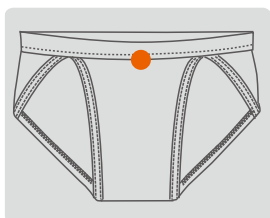

选购配件 OPTIONAL DEVICE
CL* , CAR/UTQ , CMR , CSA , CSB

- *建议采用CL后拉轮, 以提高车缝稳定性
- *CL rear puller is recommended to improve sewing stability.

① ② ③ ④ ⑤ ⑥ ⑦ ⑧ * ⑨

规格 SPECIFICATIONS C007KP- W822- 2 40/CRL/CHP/UTP/DCKU

规格索引, 详细请参考P.65 Specification index, please refer to P.65

- ① 机种别 Model
- ② 系列 Series
- ③ 网线方式 Covering Types
- ④ 功能 Function
- ⑤ 针板舌片 Needle Plate Finger
- ⑥ 针数 Needle Numbers
- ⑦ 针距 Needle gauge
- ⑧ 配件 Device
- ⑨ 马达 Motor
U: U Series
H: H Series
*UTP 请参考 Please refer to P.113

C8 Device

	⑥	⑦	⑧	⑨	S.P.M. (Max)			
C007KP-W822-⑥⑦/CRL/CHP(CY)/UTP/(⑨)	2	4	3.2/ 4.0/ 4.8	1.4 ~ 3.6	0.3 ~ 2.9	5	H / U	4500
	3	5	5.6/ 6.4	1.4 ~ 3.6	0.3 ~ 2.9	5	H / U	4500



C007KP-W822-356/CRL/CL/CHP/UTP

二合一]气动式下摆车缝 / 环型松紧带折缝
附左切刀

气动式布料导边器能将布料及松紧带顺畅的卷折, 此外左切刀切齐后再进行缝缝, 可增加包缝工程的品质与效率, 适用于男内裤、运动裤等裤头松紧带包缝。

[2 IN 1]
PNEUMATIC HEMMING / TUBULAR ELASTIC TAPE HEMMING WITH LEFT SIDE FABRIC TRIMMER

With pneumatic driving folder to fold fabric and insert elastic smoothly, left hand side fabric trimming before hemming increases sewing quality & efficiency. For hemming sleeve opening and bottom of underwears, T-shirts, or sportswears, etc...

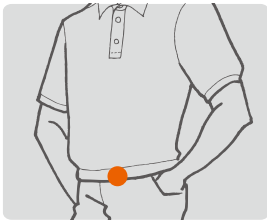

CHP (CRL 163)
气动式下摆车缝

Pneumatic Hemming



CY (CRL178-A)
气动式环型松紧带折缝

Pneumatic Tubular Elastic Tape Hemming

CHP

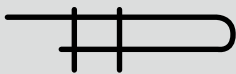

CY



适用规格 APPLICABLE SPEC

W821, W822, W823, U821, U822, U823

选购配件 OPTIONAL DEVICE

CL*, RL, UTQ, CMR, CAR/UTQ

*建议采用CL后拉轮, 以提高车缝稳定性

*CL rear puller is recommended to improve sewing stability.

规格

SPECIFICATIONS

C007KP - W152 - 3 56/ CZ/ RLQ/ DCKU

规格索引, 详细请参考P.65 Specification index, please refer to P.65

- ① 机种别 Model
- ② 系列 Series
- ③ 网线方式 Covering Types
- ④ 功能 Function
- ⑤ 针板舌片 Needle Plate Finger
- ⑥ 针数 Needle Numbers
- ⑦ 针距 Needle gauge
- ⑧ 配件 Device
- ⑨ 马达 Motor
U: U Series
H: H Series



C007KP-W152-3⑦/CZ/RLQ/(⑨)	3	5	5.6/ 6.4	1.4 ~ 3.6	0.3 ~ 2.9	5	H / U	6000
C007KP-W152-3⑦/CZP/RLQ/(⑨)	3	5	5.6/ 6.4	1.4 ~ 3.6	0.3 ~ 2.9	5	H / U	6000



C007KP-W152-356/CZ/UTP

环型罗纹裤头松紧带包缝

CZ:气动式 / CZP:膝动式

将环型罗纹松紧带缝入原体, 适用于男女内裤、裤腰的罗纹松紧带包缝再配合自动切线装置及筒型衣物撑开滚轮组, 更能提高缝制效率。
注: 本机标准配备二折式导布装置, 可另订三折式导布装置。

TUBULAR ELASTIC WAISTBAND ATTACHING

CZ:PNEUMATIC TYPE / CZP: MANUAL TYPE

Attaching tubular elastic tape onto waistband, suitable for briefs. With auto-trimming and tubular extending roller can increase sewing quality and efficiency.

Remark : Two-fold fabric guider is standard, three-fold fabric guider is optional.

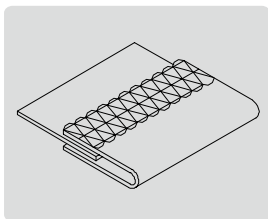
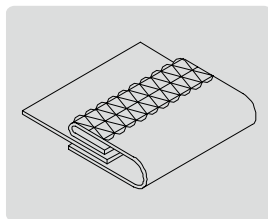
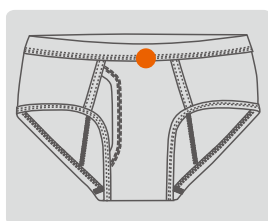

三折 3-Fold
(CZ01K,CZ03K)

两折 2-Fold
(CZ21K,CZ22K)

RLQ



机型 MODEL	选购配件 OPTIONAL DEVICE
CZ	CL*, UTP, UTQ, CMR, CAR/UTP, CAR/UTQ
CZP	CL*, UTP, UTQ, UTR, UTS, CMR, CAR/UTP, CAR/UTQ

*建议采用CL后拉轮, 以提高车缝稳定性

*CL rear puller is recommended to improve sewing stability.

规格 SPECIFICATIONS C007KP - W542 - 2 40 /CFC

规格索引, 详细请参考P.65 Specification index, please refer to P.65

- ① 机种别 Model ④ 功能 Function ⑦ 针距 Needle gauge ⑨ 马达 Motor
- ② 系列 Series ⑤ 针板舌片 Needle Plate Finger ⑧ 配件 Device U: U Series
- ③ 网线方式 Covering Types ⑥ 针数 Needle Numbers H: H Series

C10 Device

	⑥	④	⑦	⑧	⑨	⑩
C007KP-W542-⑥⑦/CFC	2	4	4.0/ 4.8	1.4 ~ 3.6	0.3 ~ 2.9	5/7 3500
	3	5	5.6/ 6.4	1.4 ~ 3.6	0.3 ~ 2.9	5/7 3500
C007KP-W542-⑥⑦/SMK	2	4	4.0/ 4.8	1.4 ~ 3.6	0.3 ~ 2.9	5/7 3500
	3	5	5.6/ 6.4	1.4 ~ 3.6	0.3 ~ 2.9	5/7 3500
C007KP-W542-⑥⑦/STC	2	4	4.0 /4.8	1.4 ~ 3.6	0.3 ~ 2.9	5/7 3500
	3	5	5.6/ 6.4	1.4 ~ 3.6	0.3 ~ 2.9	5/7 3500



SMK



STC

松紧带折缝

下送带配件能有效控制松紧带的松紧度, 配合三折或二折折布喇叭及松紧带压缝, 可准确进行短裤、内裤等裤脚及裤头的松紧带折缝。

CFC: 机械式送带

SMK: 电子计数式送带

- SMK1-D-01 附定位器, 适合简易伺服或离合器马达
- SMK1-D-02 以中继线, 连接伺服马达

STC: 张力控制式送带

- STC1-B-01 附定位器, 适合简易伺服或离合器马达
- STC1-B-02 以中继线, 连接伺服马达

ELASTIC HEMMING

Elastic hemming evenly length and elasticity is controlled by tape feeding device. Great for seam covering with two or three plies hemming binder on elastic for waistband or leg opening of briefs and shorts, etc...

CFC: Mechanic type tape feeding

SMK: Electric metering type tape feeding

- SMK1-D-01 with synchronizer for simple servo motor or clutch motor
- SMK1-D-02 Connected to servo motor by encoder cable

STC: sensor type tape feeding

- STC1-B-01 with synchronizer for simple servo motor or clutch motor
- STC1-B-02 Connected to servo motor by encoder cable

可选择的折布喇叭 Optional Binder			
喇叭型式 Binder Type	机型 Model	喇叭代号 Binder No.	成品尺寸 Finished Size
	2	B523K	9mm
	2A	B523AK	12mm
	3	B524k	9mm
	3A	B524Ak	12mm

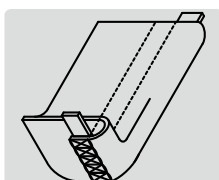
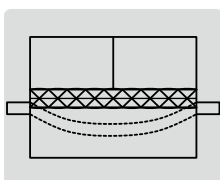
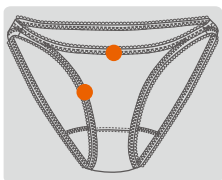

选购配件 OPTIONAL DEVICE
FH, CL*

*建议采用CL后拉轮, 以提高车缝稳定性

*CL rear puller is recommended to improve sewing stability.

规格

SPECIFICATIONS

C007KP - W122 - 2 40/ FFT/ CH/ DCKU

规格索引, 详细请参考P.65 Specification index, please refer to P.65

- ① 机种别 Model
- ② 系列 Series
- ③ 网线方式 Covering Types
- ④ 功能 Function
- ⑤ 针板舌片 Needle Plate Finger
- ⑥ 针数 Needle Numbers
- ⑦ 针距 Needle gauge
- ⑧ 配件 Device
- ⑨ 马达 Motor
U: U Series
H: H Series

C11 Device

	⑥	④	⑤	⑦	⑧	⑨	⑨	⑨	
C007KP-W122-⑥⑦/FFT/CH/⑨	2	4	4.0/ 4.8	1.4 ~ 3.6	0.3 ~ 2.9	1~5.5	5	H/U	4500
	3	5	5.6/ 6.4	1.4 ~ 3.6	0.3 ~ 2.9	1~5.5	5	H/U	4500
C007KP-W131-⑥⑦/FFT/CH/⑨	2	4	4.0/ 4.8	1.4 ~ 3.6	0.3 ~ 2.9	1~5.5	5	H/U	4500
	3	5	5.6/ 6.4	1.4 ~ 3.6	0.3 ~ 2.9	1~5.5	5	H/U	4500
C007KP-W132-⑥⑦/FFT/CH/⑨	2	4	4.0/ 4.8	1.4 ~ 3.6	0.3 ~ 2.9	1~5.5	5	H/U	4500
	3	5	5.6/ 6.4	1.4 ~ 3.6	0.3 ~ 2.9	1~5.5	5	H/U	4500
C007KP-W812A-⑥⑦/FFT/CRL/⑨	2	4	4.0/ 4.8	1.4 ~ 3.6	0.3 ~ 2.9	1~5.5	5	H/U	4500
	3	5	5.6/ 6.4	1.4 ~ 3.6	0.3 ~ 2.9	1~5.5	5	H/U	4500
C007KP-U812A-⑥⑦/FFT/CRL/⑨	2	4	4.0/ 4.8	1.4 ~ 3.6	0.3 ~ 2.9	1~5.5	5	H/U	4500
	3	5	5.6/ 6.4	1.4 ~ 3.6	0.3 ~ 2.9	1~5.5	5	H/U	4500
C007KP-W812A-⑥⑦/FFT/CRL/CW/⑨	4	6	5.6/ 6.0/ 6.4	1.4 ~ 3.6	0.3 ~ 2.9	1~5.5	5	H/U	4500



FFT 上送布功能

〔专利〕优化前后移动送具的结构设计, 有效送布的行程更大, 车缝送布更稳定。

FFT TOP FEEDING FUNCTION

Back and forth moving feed dog is designed by patent and improved mechanism. The effective feeding stroke is bigger, and fabric feeding is more stable.

选购配件 OPTIONAL DEVICE

UTP, UTR

* 薄布料建议选购 W811
Recommended for thin fabrics

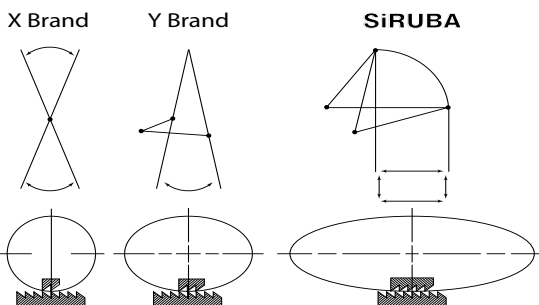

U007 SERIES FEATURES



U007 直驱超小筒型绷缝机 Ultra Small Cylinder Bed Interlock Sewing Machine



128mm角逐业界最细的小筒设计，过往缝制困难的童装袖口也可轻易车缝

128mm top-class small cylinder bed design. Conventionally difficult-to-sew small diameter tubular parts of children's clothing can be easily operated.



斜面筒嘴设计，缝制衣物著脱容易；筒身长69.7mm，方便长袖衣物套入车缝

Sharp entrance design allows quick placement/removal of material. 69.7mm cylinder length makes sewing long sleeve cuffs easily.



送布牙下送具，有别于皮带传送方式，送布力更佳、更耐用

Feed-dog design, more durable and great performance of fabric-feeding.



自动切线系列新设计气/电动上下切刀组，出刀迅速稳定准确，切线利落，轻顺低噪音调整容易

Auto trimmer with newly designed pneumatic / electric trimming system, trims precisely and stably, reduce sound and easy to adjust.



圆形粗细针缝目调整钮的设计，随心所欲准确调整缝目长短

Circular stitch length adjustment button, easily to adjust stitch length.

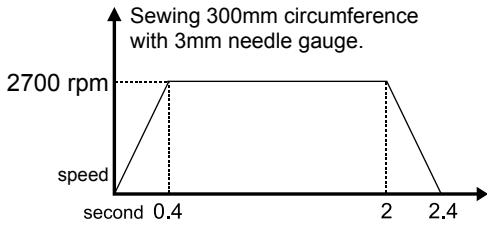

300mm圆周长不需3秒即可完工，2700rpm是对应小筒车缝的合适速度

Just take less than 3 seconds to complete 300mm circumference sewing; 2700rpm is the perfect speed for ultra small cylinder.



UCH-3M〔三合一〕一般平缝/下摆车缝/拷克倒骨盖缝

三合一模式 平缝，倒骨，折下摆，更换作业组装方便，多样化功能，高效率、低成本。

UCH-3M [3 in 1] : GENERAL SEAMING/BOTTOM HEMMING/COVERING STITCH (Fold-down type)
3-in-1 model for multifunctional and efficient production with lower cost.



① ③ ④ ⑤ ⑥ ⑦ * *





规格

SPECIFICATIONS

U007 - W122 - 2 40/ UCH-3M/ UTT(UTU)

规格索引，详细请参考P.65 Specification index, please refer to P.65

- ① 机种别 Model
 - ② 系列 Series
 - ③ 网线方式 Covering Types
 - ④ 功能 Function
 - ⑤ 针板舌片 Needle Plate Finger
 - ⑥ 针数 Needle Numbers
 - ⑦ 针距 Needle gauge
 - ⑧ 配件 Device
 - ⑨ 马达 Motor
H: H Series
- *UTT 请参考 Please refer to P.113

U007					
U007-W122-2 ⑦ /UCH-3M	2	4	4.0/ 4.8	H	2700
U007-W122-3 ⑦ /UCH-3M	3	5	5.6/ 6.4	H	2700
U007-W122-2 ⑦ /UCH-3M/UTT(UTU)*	2	4	4.0/ 4.8	H	2700
U007-W122-3 ⑦ /UCH-3M/UTT(UTU)*	3	5	5.6/ 6.4	H	2700
U007-W122-2 ⑦ /UCH-3M/UTX(UTY)*	2	4	4.0/ 4.8	H	2700
U007-W122-3 ⑦ /UCH-3M/UTX(UTY)*	3	5	5.6/ 6.4	H	2700

S007K/KD SERIES FEATURES



自动切线系列新设计上夹线装置，出刀迅速准确，夹线稳定

Auto trimmer with newly designed upper thread gripper, trims precisely and stably.



PCH-3M〔三合一〕一般平缝/下摆车缝/拷克倒骨盖缝

三合一模式 平缝，倒骨，折下摆，更换作业组装方便，多样化功能，高效率、低成本。

PCH-3M (3 in 1): GENERAL SEAMING/BOTTOM HEMMING/COVERING STITCH (Fold-down type)
3-in-1 model for multifunctional and efficient production with lower cost.



超小筒径圆周只有180毫米，车缝小孔径圆筒针织物，更加方便就手

The small cylinder designed with 180 mm, the extremely small circumference makes sewing operation smoother.



外置式底线分线盘，置于机体前方，调整容易，拆装方便，可轻易清除绞线

Front exposed looper thread take-up mechanism makes cleaning and adjusting more convenient. After fine tuning the looper thread eyelet holder, sewing can be more accurate.



调整式进布诱导器，活动式压脚，车缝适用性更广

Adjustable folder, flexible presser foot, able to accomodate wider range of sewing items.



超短筒的设计，筒边至中针距离只有39毫米，采用密封式的侧盖设计，操作方便顺畅

Extremely small tubule design, the distance from cylinder edge to middle needle is only 31 mm. Sealed side cover makes operation more convenient.



密缝装置

通过缩短送具行程，在车缝起始或结束进行密缝的功能，确保缝线不易脱落,提高车缝品质，基本车为脚踏板控制，电动和气动控制为选配。

Condense Stitching Device

By reducing the strokes of feed dog, at the beginning and the end of sewing, condense stitching reinforces the stitches. This enhances the sewing sturdiness and quality. Basic model is controlled by pedal. Electric and pneumatic controls are optional.



自动切线系列新设计气/电动上下切刀组，出刀迅速稳定准确，切线利落，轻顺低噪音调整容易

Auto trimmer with newly designed pneumatic / electric trimming system, trims precisely and stably, reduce sound and easy to adjust.



全新设计的内藏式定位器，定位准确，彻底解决外置式定位器，不易安装，调整及定位不稳的情形

Newly designed built-in synchronizer, makes position precisely and stably, easy to adjust.



圆形粗细针缝目调整钮的设计，随心所欲准确调整缝目长短

Circular stitch length adjustment button, easily to adjust stitch length.



小型投射LED照明，穿线或调整机针作业方便（选配）

LED light, convenient for threading or adjusting the needle (Optional).

规格 SPECIFICATIONS S007KD - W122 - 2 40/ PCH-3M/ DSKU

规格索引, 详细请参考P.65 Specification index, please refer to P.65

- ① 机种别 Model
- ② 系列 Series
- ③ 网线方式 Covering Types
- ④ 功能 Function
- ⑤ 针板舌片 Needle Plate Finger
- ⑥ 针数 Needle Numbers
- ⑦ 针距 Needle gauge
- ⑧ 配件 Device
- ⑨ 马达 Motor
U: U Series
H: H Series

S1 Device



S007K(D)-W122-⑥⑦/PCH-3M/(⑨)	2	4	4.0/ 4.8	1.4 ~ 4.2	0.8 ~ 1.4	5/7	H / U	4000
	3	5	5.6/ 6.4	1.4 ~ 4.2	0.8 ~ 1.4	5/7	H / U	4000

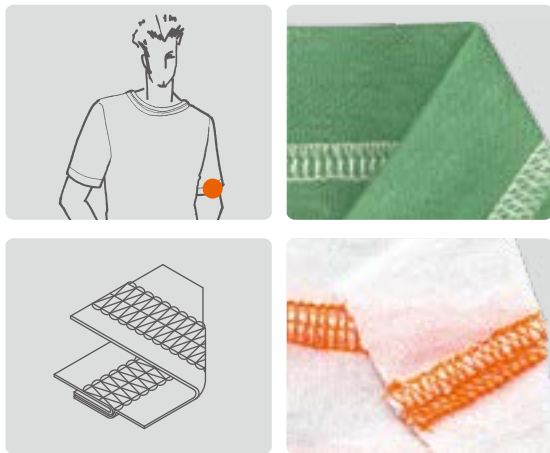

PCH-3M [三合一] 一般平缝/下摆车缝/拷克倒骨盖缝

三合一模式 平缝, 折下摆, 倒骨, 更换作业组装方便, 多样化功能, 高效率、低成本。

**PCH-3M [3 IN 1] :
GENERAL SEAMING/BOTTOM HEMMING/COVERING
STITCH (Fold-down type)**

3-in-1 model for multifunctional and efficient production with lower cost.

选购配件 OPTIONAL DEVICE
UTT, UTU, UTX, UTY, CMR, SAR/UTT, SAR/UTU

S2 Device



S007K(D)-W322-⑥⑦/PCE/(⑨)	2	4	4.0/ 4.8	1.4 ~ 4.2	0.8 ~ 1.4	5/7	H / U	4000
	3	5	5.6/ 6.4	1.4 ~ 4.2	0.8 ~ 1.4	5/7	H / U	4000

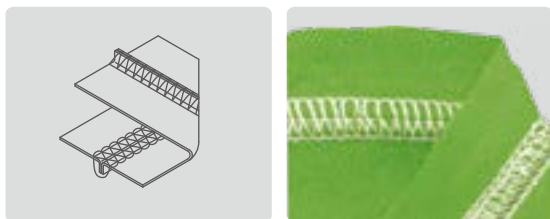

拷克立骨盖缝

适宜中厚布料, 经三线拷克车缝后再包缝, 用于运动服、汗衫等领口、下摆、袖管等的拷边车缝后加以包缝, 可增加服饰的美观及车缝的牢固, 利用导布片及压具上的压刀导缝, 可避免车缝时弯曲不直。

OVERLOCK-SEAM COVERING (Flating Type)

Bulging seam covering for medium fabric after 3 thread plain seaming, suitable for neck openings, sleeve, cuff or bottom of sportswears, T-shirts, etc... With fabric guide and special presser foot, making sewing easy and more efficient.

选购配件 OPTIONAL DEVICE
UTT, UTU, UTX, UTY, SAR/UTT, SAR/UTU, CMR

规格

SPECIFICATIONS

S007KD - W121 - 2 40 /FFT/DSKU

规格索引, 详细请参考P.65 Specification index, please refer to P.65

- ① 机种别 Model
- ② 系列 Series
- ③ 网线方式 Covering Types
- ④ 功能 Function
- ⑤ 针板舌片 Needle Plate Finger
- ⑥ 针数 Needle Numbers
- ⑦ 针距 Needle gauge
- ⑧ 配件 Device
- ⑨ 马达 Motor
U: U Series
H: H Series

S3 Device

	⑥		⑦					⑨	
S007KD-W121-⑥⑦/FFT/⑨	2	4	4.0/4.8	1.4 ~ 4.2	0.8 ~ 1.4	1~5.5	5	H / U	4000
	3	5	5.6/6.4	1.4 ~ 4.2	0.8 ~ 1.4	1~5.5	5	H / U	4000
S007KD-W122-⑥⑦/FFT/⑨	2	4	4.0/4.8	1.4 ~ 4.2	0.8 ~ 1.4	1~5.5	5	H / U	4000
	3	5	5.6/6.4	1.4 ~ 4.2	0.8 ~ 1.4	1~5.5	5	H / U	4000
S007KD-W131-⑥⑦/FFT/⑨	2	4	4.0/4.8	1.4 ~ 4.2	0.8 ~ 1.4	1~5.5	5	H / U	4000
	3	5	5.6/6.4	1.4 ~ 4.2	0.8 ~ 1.4	1~5.5	5	H / U	4000
S007KD-W132-⑥⑦/FFT/⑨	2	4	4.0/4.8	1.4 ~ 4.2	0.8 ~ 1.4	1~5.5	5	H / U	4000
	3	5	5.6/6.4	1.4 ~ 4.2	0.8 ~ 1.4	1~5.5	5	H / U	4000



FFT 上送布功能

专利优化前后移动送具的结构设计, 有效送布行程大, 车缝送布更稳定。

FFT TOP FEEDING FUNCTION

Back and forth moving feed dog is designed by patent and improved mechanism. The effective feeding stroke is bigger, and fabric feeding is more stable.

选购配件 OPTIONAL DEVICE
UTT, UTX

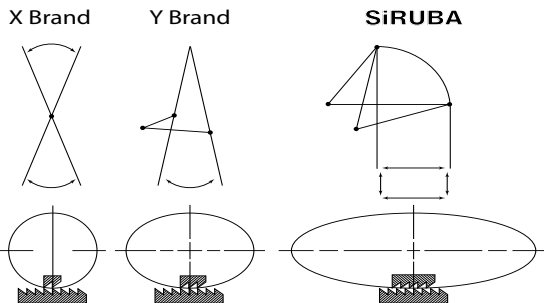

规格 SPECIFICATIONS S007KD-U173-100/SAR/RF/UTT/⑨

规格索引, 详细请参考P.65 Specification index, please refer to P.65

- ① 机种别 Model ④ 功能 Function ⑦ 针距 Needle gauge ⑨ 马达 Motor
 - ② 系列 Series ⑤ 针板舌片 Needle Plate Finger ⑧ 配件 Device
 - ③ 网线方式 Covering Types ⑥ 针数 Needle Numbers *UTT 请参考 Please refer to P.113
- U: U Series
H: H Series

S4 Device

S007KD-U173-100/SAR/RF/UTT/⑨	1	2	-	1.4 ~ 4.2	0.8 ~ 1.4	5/7	H / U	4000



S007KD-U173-100/SAR/RF/UTT/⑨

单针链缝牛仔裤辮脚机

针对弹性牛仔布料的车缝所开发的规格, 配备专用的气动式辮脚喇叭, 因为具有差动送布功能, 可以车缝出美观平整的效果。

- 标配: 气动式自动切线
气动抬压脚
直驱伺服马达
结束密缝

SINGLE NEEDLE CHAINSTITCH JEANS BOTTOM HEMMING MACHINE

Special gauge for elastic denim fabric, and equipped with pneumatic hemming folder. Because of the function of differential feeding, the sewing quality is nice and perfectly flat.

- Standard Equipment: Pneumatic thread trimmer
Pneumatic presser foot lifter
Direct drive servo motor
Condensed stitching device



S5 Device

S007KD-W812A-356/SRL/UTT/⑨	3	5	5.6	1.4 ~ 4.2	0.8 ~ 1.4	5/7	H / U	4000



S007KD-W812A-356/SRL/UTT/⑨

左切刀下摆车缝

左切刀修布边/下摆车缝工程适用于小筒型绷缝车。

BOTTOM HEMMING WITH LEFT SIDE FABRIC TRIMMER

Left edge trimmer designed for small cylinder machine with auto thread trimmer function.



F007K/KD SERIES FEATURES

全新人体工学，圆弧流线时尚的外型设计，使用方便顺手，赏心悦目
Brand new design of fashionable and smooth appearance, easy to sew.



上夹线装置

出刀迅速准确，夹线稳定。

Upper Thread Gripper

Newly designed auto trimmer trims precisely and stably.



内缩式床台

缝制物更靠近机针，车缝定位准确，车缝时更加顺畅就手。

The Recessed Machine Bed

The sewing material is closer to the needle and the sewing is precise, which makes sewing operation easier and smoother.



拷克骨车缝附调整式进布诱导器，活动式压脚，车缝适用性更广

Cover seaming with adjustable folder, flexible presser foot, accommodate wider range of sewing items.



自动切线系列新设计气/电动上下切刀组

出刀迅速稳定准确，切线利落，轻顺低噪音调整容易。

Auto trimmer with newly designed pneumatic / electric trimming system

trims precisely and stably, lower sound and easy to adjust.



规格

SPECIFICATIONS

F007KD - W121 - 2 40 /FHA/DFKU

规格索引, 详细请参考P.65 Specification index, please refer to P.65

- ① 机种别 Model
- ② 系列 Series
- ③ 网线方式 Covering Types
- ④ 功能 Function
- ⑤ 针板舌片 Needle Plate Finger
- ⑥ 针数 Needle Numbers
- ⑦ 针距 Needle gauge
- ⑧ 配件 Device
- ⑨ 马达 Motor
U: U Series
H: H Series

F1 Device

	⑥		⑦				⑨	
F007K(D)-W121-⑥⑦/FHA/(⑨)	2	4	4.0/4.8	1.6 ~ 4.2	0.5 ~ 1.3	5	H / U	6000
	3	5	5.6/6.4	1.6 ~ 4.2	0.5 ~ 1.3	5	H / U	6000
F007K(D)-W122-⑥⑦/FHA/(⑨)	2	4	4.0/4.8	1.6 ~ 4.2	0.5 ~ 1.3	5	H / U	6000
	3	5	5.6/6.4	1.6 ~ 4.2	0.5 ~ 1.3	5	H / U	6000
F007K(D)-W123-⑥⑦/FHA/(⑨)	2	4	4.0/4.8	1.6 ~ 4.2	0.5 ~ 1.3	5/7	H / U	6000
	3	5	5.6/6.4	1.6 ~ 4.2	0.5 ~ 1.3	5/7	H / U	6000
F007K(D)-W162-⑥⑦/FHA/(⑨)	3	5	5.6/6.4	1.6 ~ 4.2	0.5 ~ 1.3	5/7	H / U	6000
F007K(D)-W162H-⑥⑦/FHA/(⑨)	3	5	5.6/6.4	6	0.5 ~ 1.3	5/7	H / U	6000

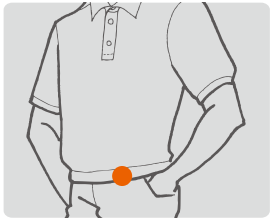

一般平缝 / 下摆车缝

本机型为双面饰绷缝筒车的基本机型, 可装配附件进行多种功能车缝例如: 内衣裤、运动衫接缝及下摆车缝(附可调式下摆车缝组)。

GENERAL SEAMING / BOTTOM HEMMING

Basic model of interlock Sewing machine with double side cover-stitching. It is available for various sewing by optional devices. Such as plain seaming and bottom hemming for underwears, sportswears, etc... (equipped with adjustable hemming set)

- | | | |
|----------------|-----------------|--|
| W121 : | 薄布料 | Light material |
| W122 : | 中厚布料 | Medium material |
| W123 : | 厚布料 | Heavy material |
| W162 : | 高行程 | High needle bar stroke |
| W162H : | 高行程
大针距(6mm) | High needle bar stroke
Long stitch length (6mm) |

选购配件 OPTIONAL DEVICE

UTG, UTH, UTJ, UTK, FL

规格

SPECIFICATIONS

F007KD - W222 - 2 40 /FQ/DFKU

规格索引, 详细请参考P.65 Specification index, please refer to P.65

- ① 机种别 Model
- ② 系列 Series
- ③ 网线方式 Covering Types
- ④ 功能 Function
- ⑤ 针板舌片 Needle Plate Finger
- ⑥ 针数 Needle Numbers
- ⑦ 针距 Needle gauge
- ⑧ 配件 Device
- ⑨ 马达 Motor
U: U Series
H: H Series

F2 Device



F007K(D)-W222-⑥⑦/FQ/(⑨)	2	4	4.0/4.8	1.6 ~ 4.2	0.5 ~ 1.3	5	H / U	6000
	3	5	5.6/6.4	1.6 ~ 4.2	0.5 ~ 1.3	5	H / U	6000
F007K(D)-W222-⑥⑦/FFD/(⑨)	2	4	4.0/4.8	1.6 ~ 4.2	0.5 ~ 1.3	5	H / U	6000
	3	5	5.6/6.4	1.6 ~ 4.2	0.5 ~ 1.3	5	H / U	6000
F007K(D)-W222-⑥⑦/FFP/(⑨)	2	4	4.0/4.8	1.6 ~ 4.2	0.5 ~ 1.3	5	H / U	6000
	3	5	5.6/6.4	1.6 ~ 4.2	0.5 ~ 1.3	5	H / U	6000



F007K-W222-356/FQ/FEC



F007K-W222-356/FFD



F007K-W222-356/FFP

FQ:上带滚边车缝

适用于T恤、内衣裤的领口、裤管口等上带滚边的车缝工程, 可加附电动(FEC)或气动式(FAC)长切刀式切布条装置, 能将滚边布条切断, 节省布条的用料增加车缝效率。

FQ:TAPE BINDING

For tape binding on openings of leg or neck of underwears, T-shirts, etc... Also can attach electric(FEC) or pneumatic(FAC) tape cutter to save tape and increase sewing efficiency.



◀ 以上机型可加装
FNC, FSC:
电眼型后切刀附直驱马达

Optional device for the above models
FNC, FSC:
Sensor type rear cutter with direct drive servo motor

FFD / FFP:上带滚边车缝包覆松紧带

上送带装置控制松紧带张力, 加上膝动控制松紧带的左右移动, 能有效让松紧带前后段与衣身车缝固定, 适用于内裤的裤头、裤脚的滚边加松紧带的车缝工程。

FFD: 齿轮箱型准确张力控制

FFP: 弹簧片型简易张力控制

FFD / FFP:TAPE BINDING WITH ELASTIC BAND

Top feeding device controls the elastic band's tension. Elastic band right-left position controller (by knee-pushing) sets the materials joining at the beginning and ending of waistband, leg opening of briefs...etc.

FFD: Gearbox type for accurate tension control

FFP: Spring type for simple tension control

选购配件 OPTIONAL DEVICE

FA, LF-A, FAC, FEC, LS-A

规格 SPECIFICATIONS F007K - W222 - 2 40 /FSM

规格索引, 详细请参考P.65 Specification index, please refer to P.65

- ① 机种别 Model ④ 功能 Function ⑦ 针距 Needle gauge
- ② 系列 Series ⑤ 针板舌片 Needle Plate Finger ⑧ 配件 Device
- ③ 网线方式 Covering Types ⑥ 针数 Needle Numbers

F3 Device

	⑥	⑧	⑦	④	⑤	③	②
F007K-W222-240-4/FSM	2	8	4.0	1.6 ~ 4.2	0.5 ~ 1.3	5	2500
F007K-W222-248-4/FSM	2	8	4.8	1.6 ~ 4.2	0.5 ~ 1.3	5	2500
F007K-W222-364-4/FSM	3	9	6.4	1.6 ~ 4.2	0.5 ~ 1.3	5	2500



F007K-W222-356/FSM

花饰滚边车缝

用于T恤衫、衬衫等领口、下摆、袖口等花饰滚边车缝, 附有四组花饰凸轮可变化成数百种车缝花样。

ORNAMENTAL TAPE BINDING

Suitable for ornamental tape binding of neck band, bottom or cuff of T-shirts, shirts, etc...

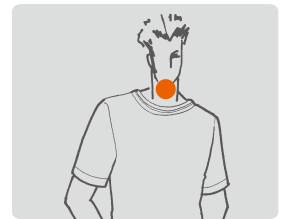

选购配件 OPTIONAL DEVICE
FA

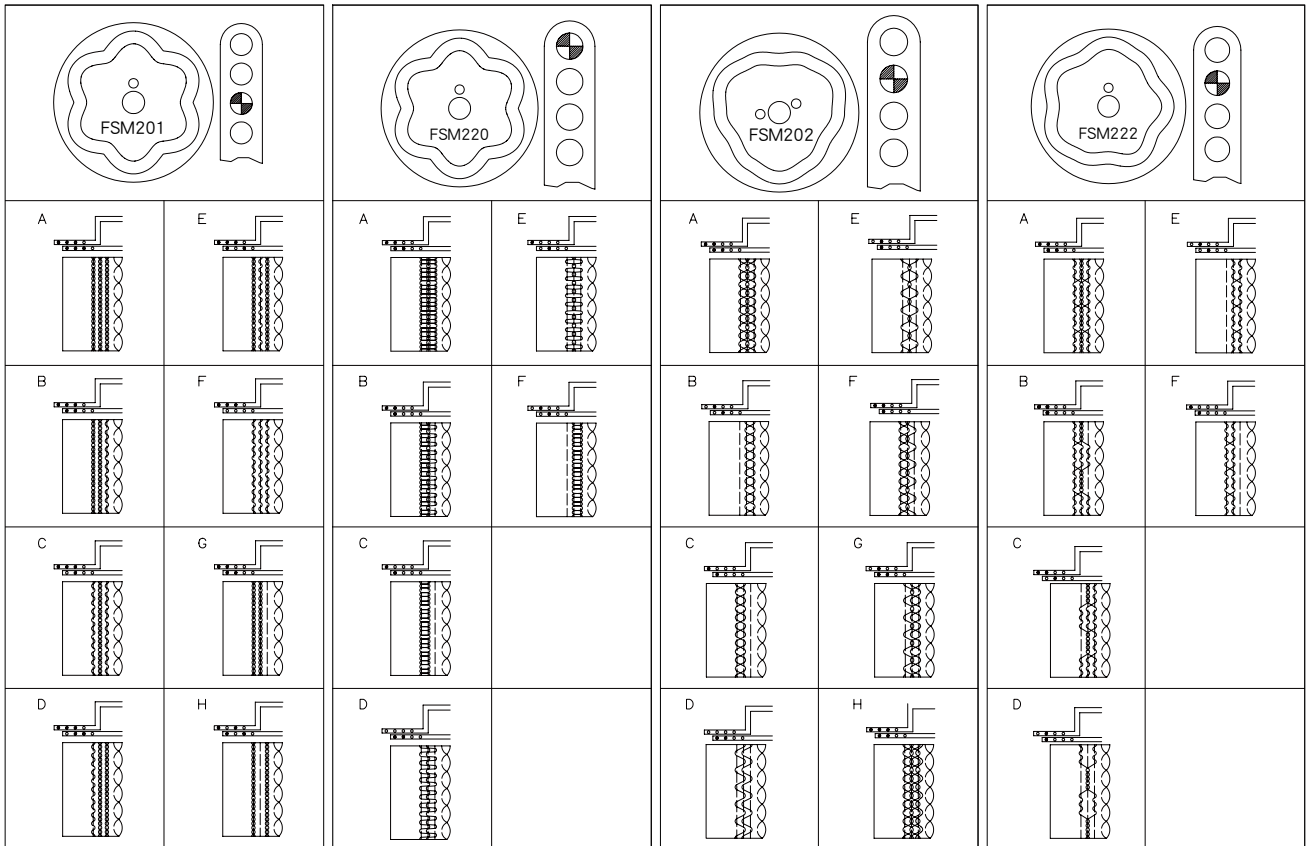

规格

SPECIFICATIONS

F007KD - W322 - 3 56 /FDC/DFKU

规格索引, 详细请参考P.65 Specification index, please refer to P.65

- ① 机种别 Model
- ② 系列 Series
- ③ 网线方式 Covering Types
- ④ 功能 Function
- ⑤ 针板舌片 Needle Plate Finger
- ⑥ 针数 Needle Numbers
- ⑦ 针距 Needle gauge
- ⑧ 配件 Device
- ⑨ 马达 Motor
U: U Series
H: H Series

F4 Device

	⑥	⑤	⑤.6/6.4	⑦	mm	mm	⑨	S.P.M. (Max)
F007K(D)-W322-⑥⑦/FDC/(⑨)	3	5	5.6/6.4	1.6 ~ 4.2	0.5 ~ 1.3	5	H / U	6000
F007K(D)-W322-⑥⑦/FDE/(⑨)	3	5	5.6/6.4	1.6 ~ 4.2	0.5 ~ 1.3	5	H / U	6000



F007K-W222-356/FDC



F007KD-W322-356/FDE/UTJ/⑨

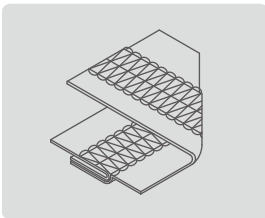

FDC



FDC

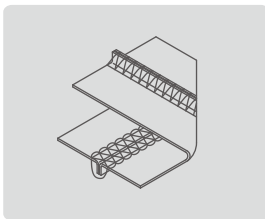

FDE



FDE

拷克倒骨盖缝

FDC 倒骨型: 适用于4线包缝的盖缝。

FDE 立骨型: 适用于3线包缝的盖缝。

配件盒另附有FDC倒骨规格的牛角(导布片)。

OVERLOCK-SEAM COVERING STITCH

FDC Fold-down type: For 4-thread overlock-seam covering stitch.

FDE Flattening type: For 3-thread overlock-seam covering stitch, and an extra guide of overlock-seam (FDC specification, fold-down type) is included in the accessory box.

选购配件 OPTIONAL DEVICE

UTG, UTH, UTJ, UTK

规格

SPECIFICATIONS

F007K - W522 - 2 40 /FR /FFC

规格索引, 详细请参考P.65 Specification index, please refer to P.65

- ① 机种别 Model ④ 功能 Function ⑦ 针距 Needle gauge
- ② 系列 Series ⑤ 针板舌片 Needle Plate Finger ⑧ 配件 Device
- ③ 网线方式 Covering Types ⑥ 针数 Needle Numbers

F5 Device

	⑥	⑤	⑦	④	③	②	①
F007K-W522-⑥⑦/FR/FFC	2	4	4.0/4.8	1.6 ~ 4.2	0.5 ~ 1.3	5	4500
	3	5	5.6/6.4	1.6 ~ 4.2	0.5 ~ 1.3	5	4500
F007K-W522-⑥⑦/FR/FE	2	4	4.0/4.8	1.6 ~ 4.2	0.5 ~ 1.3	5	4500
	3	5	5.6/6.4	1.6 ~ 4.2	0.5 ~ 1.3	5	4500
F007K-W522-⑥⑦/FR/SMK	2	4	4.0/4.8	1.6 ~ 4.2	0.5 ~ 1.3	5	4500
	3	5	5.6/6.4	1.6 ~ 4.2	0.5 ~ 1.3	5	4500
F007K-W522-⑥⑦/FR/STC	2	4	4.0/4.8	1.6 ~ 4.2	0.5 ~ 1.3	5	4500
	3	5	5.6/6.4	1.6 ~ 4.2	0.5 ~ 1.3	5	4500



F007K-W522-240/FR/FE/FAC



SMK



STC



松紧带 / 蕾丝松紧带上带车缝附右切刀

由上送带装置, 控制长度与张力, 附右切刀修布装置, 能于车缝前将布修齐, 更能提高车缝品质, 如女用内衣裤的松紧带或蕾丝松紧带车缝。

FFC: 机械式送带

FE: 简易电子式送带

SMK: 电子计数器送带

SMK1-C-01 附定位器, 适合简易伺服或离合器马达

SMK1-C-02 以中继线, 连接伺服马达张力控制式送带

STC: 张力控制式送带

STC1-U-01 附定位器, 适合简易伺服或离合器马达

STC1-U-02 以中继线, 连接伺服马达张力控制式送带

ELASTIC / LACE ATTACHING WITH RIGHT FABRIC TRIMMER

Top feeding devices ensure even length and tension controlled by electric digital controller, with right side fabric trimmer for elastic or lace attaching smoothly and properly on women's underwears.

FFC: Mechanic type tape feeding.

FE: Simple electric type tape feeding.

SMK: Electric metering type tape feeding

SMK1-C-01 with synchronizer for simple servo motor or clutch motor

SMK1-C-02 Connected to servo motor by encoder cable

STC: Tension sensor type tape feeding

STC1-U-01 with synchronizer for simple servo motor or clutch motor

STC1-U-02 Connected to servo motor by encoder cable

选购配件 OPTIONAL DEVICE

FAC, FEC, LF-A, LS-A

规格

SPECIFICATIONS

F007K - W522 - 2 40 /FR /FQS

规格索引, 详细请参考P.65 Specification index, please refer to P.65

- ① 机种别 Model
- ② 系列 Series
- ③ 网线方式 Covering Types
- ④ 功能 Function
- ⑤ 针板舌片 Needle Plate Finger
- ⑥ 针数 Needle Numbers
- ⑦ 针距 Needle gauge
- ⑧ 配件 Device

F6 Device

F007K-W522-2⑦/FR/FQS	2	4	3.2/4.0	1.6~4.2	0.5~1.3	5	4500



F007K-W522-240/FR/FQS

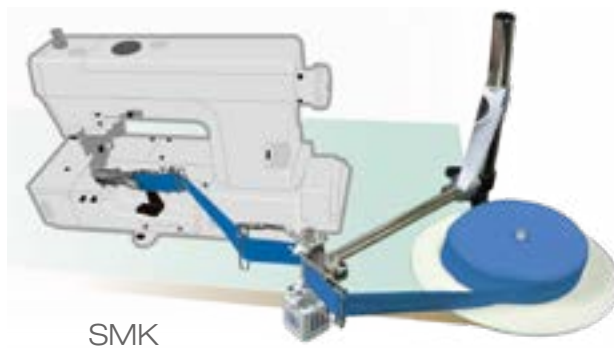

SMK

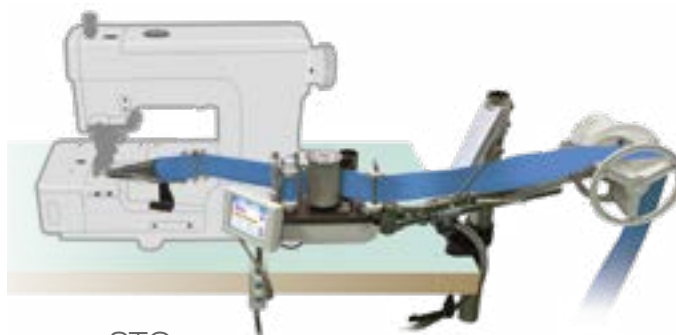

STC

细滚边车缝 (右切刀机型附侧送小喇叭)

本机型适用于女性内裤或丁字裤的细滚边车缝, 在滚边的前先经右切刀修布, 避免发生爆缝问题, 可搭配以下送带装置

SMK: 电子计数式送带

- SMK1-E-01 附定位器, 适合简易伺服或离合器马达
- SMK1-E-02 以中继线, 连接伺服马达张力控制式送带

STC: 张力控制式送带

- STC1-S-01 附定位器, 适合简易伺服或离合器马达
- STC1-S-02 以中继线, 连接伺服马达

FINE TAPE BINDING (RIGHT SIDE FABRIC TRIMMER MODEL WITH SMALL BINDER)

This machine is applicable for fine tape binding of women's underwear or T-string. Before tape binding, the fabric edge is trimmed by the right trimmer. This solves the problem of bad binding, which the tape is not sewn on the fabric. The below tape feeding devices are applicable.

SMK: Electric metering type tape feeding

- SMK1-E-01 with synchronizer for simple servo motor or clutch motor
- SMK1-E-02 Connected to servo motor by encoder cable

STC: Tension sensor type tape feeding

- STC1-S-01 with synchronizer for simple servo motor or clutch motor
- STC1-S-02 Connected to servo motor by encoder cable

选购配件 OPTIONAL DEVICE

FAC, FEC, LF-A, LS-A, TUA

规格

SPECIFICATIONS

① ② ③ ④ ⑤ ⑥ ⑦ ⑧ ⑨
F007KD - U122 - 2 32 /FP /DFKU

规格索引, 详细请参考P.65 Specification index, please refer to P.65

- ① 机种别 Model
- ② 系列 Series
- ③ 网线方式 Covering Types
- ④ 功能 Function
- ⑤ 针板舌片 Needle Plate Finger
- ⑥ 针数 Needle Numbers
- ⑦ 针距 Needle gauge
- ⑧ 配件 Device
- ⑨ 马达 Motor
 U: U Series
 H: H Series

F7 Device



F007K(D)-U122-232/FP/(⑨)	2	3	3.2	1.6 ~ 4.2	0.5 ~ 1.3	7	H / U	6000
--------------------------	---	---	-----	-----------	-----------	---	-------	------



F007K-U122-232/FP

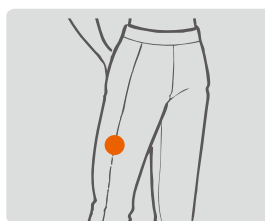

折线条车缝

本机种适用于运动服、牛仔或其他服饰的凸面折线条车缝, 车缝时可于折线条内另加缝线绳, 以增加凸线条的立体感和装饰效果。

PINTUCK SEAMING

To sew a decorative convex stripe on sportswears, jeans or other clothes, can also add extra stripe inside convex to increase the effects of convexity and decoration.

F8 Device



F007K(D)-U613-2⑦/FBP/(⑨)	2	3	5.6/6.4	1.6 ~ 4.2	0.5 ~ 1.3	7	H / U	6000
--------------------------	---	---	---------	-----------	-----------	---	-------	------



F007K-U613-256/FBP

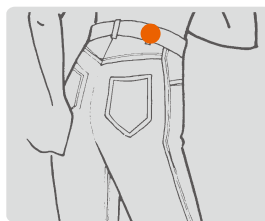

裤耳车缝

利用已裁好的等宽布条连续快速制作裤耳。

BELT-LOOP SEAMING

Mass production for belt loop by using stripped tape.

选购配件 OPTIONAL DEVICE

LF-A, LS-A

规格

SPECIFICATIONS

F007KD -U712A -264 /FSP/DFKU

规格索引, 详细请参考P.65 Specification index, please refer to P.65

- ① 机种别 Model
- ② 系列 Series
- ③ 网线方式 Covering Types
- ④ 功能 Function
- ⑤ 针板舌片 Needle Plate Finger
- ⑥ 针数 Needle Numbers
- ⑦ 针距 Needle gauge
- ⑧ 配件 Device
- ⑨ 马达 Motor
U: U Series
H: H Series

F9 Device

	⑥	⑤	⑦	⑦	⑨	⑨	⑨	S.P.M. (Max)
F007K(D)-U712(A)-264/FSP/(⑨)	2	4	6.4	1.6 ~ 4.2	0.5 ~ 1.3	5	H / U	6000
F007K(D)-U712-496/FSS/(⑨)	4	6	9.6	1.6 ~ 4.2	0.5 ~ 1.3	5	H / U	6000
F007K(D)-U712-4111/FSS/(⑨)	4	6	11.1	1.6 ~ 4.2	0.5 ~ 1.3	5	H / U	6000



F007K-U712-264/FSP

选购配件 OPTIONAL DEVICE

LF-A, LS-A

布条车缝 (双针双勾)

本机系将拷克后的拷克骨缝上布条以补强及增加美观的用, 如男内裤、休闲裤等的车缝。

U712: 成品宽度10mm

U712A: 成品宽度12mm

TAPE ATTACHING (TWO NEEDLE, TWO LOOPER)

This machine is specially for tape binding on cross seaming of men's briefs or sportswears to strengthen plain seam and for ornamental purpose.

U712: finished tape width 10mm

U712A: finished tape width 12mm

布条车缝 (四针双勾)

本机系将拷克后的拷克骨缝上布条以补强及增加美观的用, 如男内裤、休闲裤等的车缝。

TAPE ATTACHING (FOUR NEEDLE, TWO LOOPER)

This machine is specially for tape binding on cross seaming of men's briefs or sportswears to strengthen plain seam and for ornamental purpose.

F10 Device

	⑥	⑤	⑦	⑦	⑨	⑨	⑨	S.P.M. (Max)
F007K(D)-U712-264/FSR/(⑨)	2	4	6.4	1.6 ~ 4.2	0.5 ~ 1.3	5	H / U	6000



F007K-U712-264/FSR

卷叠缝

本机种设计特殊的左右齿差动方式, 能使卷叠缝缝纫更顺畅车缝后左右二片布均一无长短的虞, 适用于西裤、休闲裤、牛仔裤薄至厚布料等的卷边叠缝。

LAP SEAMING

Differential ratio of left and right feed dog can be adjusted separately for lap seaming to ensure symmetrical length to both left and right fabric. Applicable to trousers, casual pants and jeans, etc...

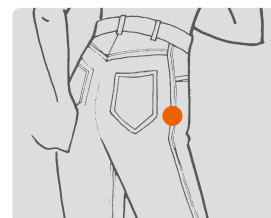

规格 SPECIFICATIONS F007KD - W722 - 3 88 /FY /DFKU

规格索引, 详细请参考P.65 Specification index, please refer to P.65

- ① 机种别 Model
- ② 系列 Series
- ③ 网线方式 Covering Types
- ④ 功能 Function
- ⑤ 针板舌片 Needle Plate Finger
- ⑥ 针数 Needle Numbers
- ⑦ 针距 Needle gauge
- ⑧ 配件 Device
- ⑨ 马达 Motor
U: U Series
H: H Series

F11 Device

F007K(D)-W722-388/FY/(⑨)	3	7	8.8	1.6 ~ 4.2	0.5 ~ 1.3	5	H / U	6000



F007K-W722-388/FY

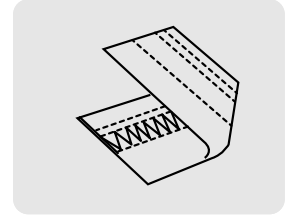
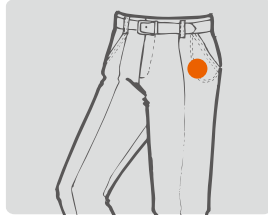

裤袋里车缝

本机为三针三勾针一上叉, 可同时缝合裤袋内里与表布并强化车缝处的牢固, 增加美观提高效率, 适用于西裤、工作裤等。

POCKET LINING SEAMING

This is a 3 needles 3 loopers 1 spreader machine, and special for seaming the shell fabric and lining of pocket in trousers or work pants in simple operation to increase sewing quality and efficiency.

F12 Device

F007K(D)-W922-456/FW/(⑨)	4	6	5.6	1.6 ~ 4.2	0.5 ~ 1.3	5	H / U	6000
F007K(D)-W922-460/FW/(⑨)	4	6	6.0	1.6 ~ 4.2	0.5 ~ 1.3	5	H / U	6000
F007K(D)-W922-464/FW/(⑨)	4	6	6.4	1.6 ~ 4.2	0.5 ~ 1.3	5	H / U	6000



F007K-W922-456/FW

四针六线搭接缝车缝

适用于一般内衣裤二片布接缝处的接缝和补强, 附有专属的导边, 可使二片布顺畅缝合。

FOUR-NEEDLE FLAT SEAMING

For flat seaming 2 pieces of fabric. Equipped with fabric guide for easy operation.

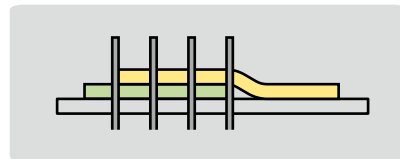

选购配件	OPTIONAL DEVICE
	UTH, UTK

FW- 4	四针, 无假针, 适用上网线切线刀 4 needles Without retainer, applicable to upper thread trimmer
FW- 4A	配特殊针板 E1838P, 适合车缝运动鞋装饰线 With special needle plate E1838P, applicable to shoe decoration
FW- 5	四针, 有假针, 不适用上网线切线刀 4 needles with retainer, not applicable to upper thread trimmer

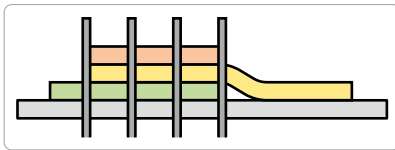

FWP

附喇叭 (B417R) 与导带架

With folder (B417R) and tape guide.

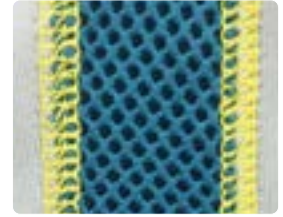
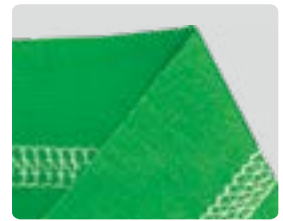
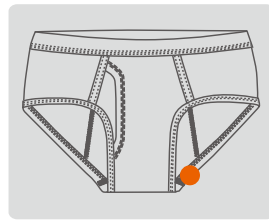

FW-4A

规格 SPECIFICATIONS F007KD - W121 - 2 40/ FFT/ FHA/ DFKU

规格索引, 详细请参考P65 Specification index, please refer to P65

- ① 机种别 Model ④ 功能 Function ⑦ 针距 Needle gauge ⑨ 马达 Motor
- ② 系列 Series ⑤ 针板舌片 Needle Plate Finger ⑧ 配件 Device U: U Series
- ③ 网线方式 Covering Types ⑥ 针数 Needle Numbers H: H Series

F13 Device

F007KD-W121-⑥⑦/FFT/FHA/⑨	2	4	4.0/ 4.8	1.6 ~ 4.2	0.5 ~ 1.3	1~5.5	5	H / U	4500
	3	5	5.6/ 6.4	1.6 ~ 4.2	0.5 ~ 1.3	1~5.5	5	H / U	4500
F007KD-W122-⑥⑦/FFT/FHA/⑨	2	4	4.0/ 4.8	1.6 ~ 4.2	0.5 ~ 1.3	1~5.5	5	H / U	4500
	3	5	5.6/ 6.4	1.6 ~ 4.2	0.5 ~ 1.3	1~5.5	5	H / U	4500
F007KD-W131-⑥⑦/FFT/FHA/⑨	2	4	4.0/ 4.8	1.6 ~ 4.2	0.5 ~ 1.3	1~5.5	5	H / U	4500
	3	5	5.6/ 6.4	1.6 ~ 4.2	0.5 ~ 1.3	1~5.5	5	H / U	4500
F007KD-W132-⑥⑦/FFT/FHA/⑨	2	4	4.0/ 4.8	1.6 ~ 4.2	0.5 ~ 1.3	1~5.5	5	H / U	4500
	3	5	5.6/ 6.4	1.6 ~ 4.2	0.5 ~ 1.3	1~5.5	5	H / U	4500



FFT 上送布功能

(专利)优化前后移动送具的结构设计, 有效送布行程大, 车缝送布更稳定。

FFT TOP FEEDING FUNCTION

Back and forth moving feed dog is designed by patent and improved mechanism. The effective feeding stroke is bigger, and fabric feeding is more stable.

选购配件 OPTIONAL DEVICE
UTG, UTJ

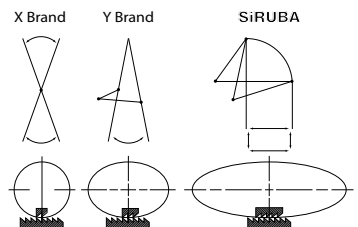

DEVICE

高弹面料用针板代号 Needle Plate for Highly Elastic Fabrics

适用机型 applicable model	ITEM	
F007K(D)-W122-356	E1836EF	
C007L-W121(W122)-356 C007L-U121(U122)-356 C007L-W121(W122)-356/RH/RCH-3M C007L-U121(U122)-356/RH/RCH-3M C007KP-W122-356/CH C007KP-W122-356/CH-4M	E5356EF	
C007L-W811A(W812A, W813A)-356/CRL C007KP-W811A(W812A, W813A)-356/CRL	E0226QF	
S007K(D)-W121-356/PCH-3M S007K(D)-W122-356/PCH-3M	E3996EF	
S007K-W812A-356/SRL	E3996RF	



CAR

气动式密缝装置 Pneumatic Condense Stitching Device (CAR/SAR)

膝动式密缝装置 Manual Condense Stitching Device (CMR)

通过缩短送具行程，在车缝起始或结束时进行密缝的功能，确保缝线不易脱落，提高车缝品质，基本车为脚踏板控制，电动和气动控制为选配，本配件需更换专用规格组。

By reducing the strokes of feed dog, at the beginning and the end of sewing, condense stitching reinforces the stitches. This enhances the sewing sturdiness and quality. Basic model is controlled by pedal. Electric and pneumatic controls are optional. Exclusive gauge sets is required.



SAR



CMR

Applicable Model	CAR (Pneumatic)	SAR (Pneumatic)	CMR (Manual)
C007KP	√	×	√
S007K S007K/DS□	×	√	√

可自行组装 self-installation : YES



CAF

气动式持压控制装置 Pneumatic Presser Foot Pressure Regulator

1. 气动式持压控制装置，运用气动让压脚压力保持在均匀且最低限度的控制下，稳定持压下无论弹性、极薄布料都可即时调整成适合的压脚压力。
2. 气压调节阀简单操作，即时目测当下压脚压力并弹性调整，缩短调整时间、提高生产效率。

*注：1. 需有空压设备 2. 搭配伺服马达使用

1. Pneumatic Presser Foot Pressure Regulator uses the pneumatic device to keep the presser foot pressure under uniform and minimal control. It can be adjusted to the suitable presser foot pressure in real time regardless of the elasticity or extremely thin fabric under stable holding pressure.
2. The pressure regulating valve is easy to operate, instantly visually detect the current pressure of the presser foot and adjust it flexibly, shortening the adjustment time and improving production efficiency.

*Note: 1. Air pressure equipment is required 2. Used with servo motor

可自行组装 self-installation : NO

适用机型 applicable model : 全系列绷缝机 All Interlock Series



CC

拷克倒骨盖缝装置 Overlock- Seam Covering (Fold-down Type)

1. 适中厚至厚布料经四线拷克车包缝后的饰缝。
2. 对于运动服，领子，衣襟，袖管的拷边车缝后加以单面或双面装饰环缝，可增加服饰的美观及车缝的牢固。利用导布片及压具上的压刀导缝，可避免车缝时弯曲不直。

1. Overturned seam covering for medium to heavy fabric after 4 thread plain seaming.
2. Suitable for neck openings, sleeve, cuff or bottom of sportswears, T-shirts, etc... With fabric guide and special presser foot making sewing easy and more efficient.

可自行组装 self-installation : YES

适用机型 applicable model : C007KP-W322, C007L-W322



CE

立骨盖缝装置 Overlock-Seam Covering (Flattening Type)

1. 适中厚布料经三线拷克车包缝后的饰缝。
2. 对于运动服，领子，衣襟，袖管的拷边车缝后加以单面或双面装饰环缝，可增加服饰的美观及车缝的牢固。利用导布片及压具上的压刀导缝，可避免车缝弯曲不直。

1. Bulging seam covering for medium fabric after 3 thread plain seaming.
2. Suitable for neck openings, sleeve, cuff or bottom of sportswears, T-shirts, etc... With fabric guide and special presser foot making sewing easy and more efficient.

可自行组装 self-installation : YES

适用机型 applicable model : C007KP-W322, C007L-W322, C007L-U322



CFC

松紧带折缝 Elastic Hemming

经由齿轮控制箱的控制，能有效控制松紧带的松紧度，配合三折或二折折布喇叭及松紧带压缝，可准确完美地进行短裤、内裤等裤脚及裤头的松紧带折缝。

Elastic hemming evenly length and elasticity is controlled by gear box. Great for seam covering with two or three plies hemming binder on elastic for waistband or leg opening of briefs and shorts's, etc...

可自行组装 self-installation : NO

适用机型 applicable model : C007KP-W542



CH

下摆车缝 Hemming

T恤、内衣及儿童服饰下摆及袖口的车缝，可随需要调整下摆饰缝组宽度，操作简单快捷。

Suitable for the bottom hemming of T-shirts, underwears, cuff of children's garments, etc... Able to adjust the width of hemming set to fit demands, easy operation.

可自行组装 self-installation : YES

适用机型 applicable model : C007KP-W121, C007KP-W122, C007KP-W123, C007KP-W162, C007L-W122, C007L-W162, C007L-U122



CHP

[二合一]气动式下摆车缝 / 环型松紧带折缝附左切刀

[2 IN 1]Pneumatic Hemming / Tubular Elastic Tape hemming with Left Side Fabric Trimmer

气动式布料导边器能将布料及松紧带顺畅的卷折，此外左切刀切齐后再进行缝纫，可增加包缝工程的品质与效率，适用于男内裤、运动裤等裤头松紧带包缝。

With pneumatic driving folder to fold fabric and insert elastic smoothly, left hand side fabric trimming before hemming increases sewing quality & efficiency. For hemming sleeve opening and bottom of underwears, T-shirts, or sportswears, etc...

可自行组装 self-installation : NO

适用机型 applicable model : C007KP-W822



CY



CL

后拉引滚轮 Rear Puller

1. 可拉车缝过后的布及松紧带，使其不会产生车缝过后挤压的毛病，以达到车缝平顺快速的效果。
2. 本辅助件同时内附齿状滚轮CL (CL19+ CL53) 与平面滚轮CLA (CL20+CL52)，供客户依车缝布料的不同来选择使用。一般布料用平面滚轮，但另车缝松紧带或蕾丝松紧带时，请用齿状滚轮。
3. 为能正确地校缝，机器装配时会按实际需要装齿状滚轮与平面滚轮，但于配件盒附上另一组齿轮。



CLA

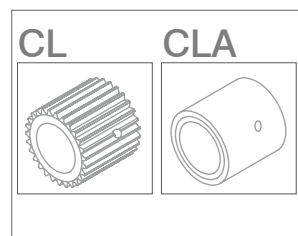

1. Pulls the fabric and elastic after sewing and makes sewing fast, flat and smooth without wrinkles.
2. The attachment includes both CL(CL19+CL53) and CLA(CL20+CL52). CLA is flat type for normal material, and CL is serrated type for elastic or lace, etc...
3. For fine-tuning purpose, the machine will be equipped with one rear puller depending on actual demand, the other one will be placed in the accessory box.

可自行组装 self-installation : NO

适用机型 applicable model : C007KP



CQ

上带滚边车缝 Tape Binding

1. T 恤、内衣裤、儿童服饰等领口、袖口和裤管口的包边。
2. 订购内附CQ的机器内附FG组，但个别购买CQ装置时则不另附FG组。
3. 包边喇叭的标准规格为入布宽度1-3/8"，出布时成三折，宽度为1/2"。若需订购标准品以外的尺寸，请于订购时特别说明，但交期及费用另计。
4. 本辅助件有三种订购方式：

1. For tape binding on openings of leg or neck of underwears, T-shirts, etc...
2. If purchased machine with CQ device, FG device will also be included. If only CQ device were purchased, no FG included.
3. Binder's standard tape size is 1-3/8" wide and finished size is 1/2" wide in 3 folds. Please remark if need another size when ordering, delivery and cost will be recalculated.
4. Ways to order the device:

机型 Model	CQ	FG	CQ 规格组 CQ Gauge Set	喇叭 Binder
C007KP-W222-240/CQ	√	√	√	√
C007KP-W222-240	X	X	√	X
C007KP-W222-240/CQ-P	√	√	√	X

可自行组装 self-installation : YES

适用机型 applicable model : C007KP-W222



CR

右切刀装置 Right Side Fabric Trimmer

修齐右边或右下方多余的布料，使衣物车缝后更加整齐美观；附加吸布屑装置更能保持工作环境干净。

Right hand side waste fabric trimming with waste suction device makes fabric edge aligned to seam and keeps the working area clean.

可自行组装 self-installation : NO

适用机型 applicable model : C007KP-W522, C007KP-W532, C007L-W532, C007L-U532



CRL

左切刀装置 Left Side Fabric Trimmer

修齐二片布接缝的左下方多余的布料，使衣物车缝后更加整齐美观。

Left hand side fabric trimming makes fabric edge aligned to seam.

可自行组装 self-installation : NO

适用机型 applicable model : C007KP-W812(A), C007KP-W822, C007L-W812, C007L-U812, C007L-W822



CW

四针六线环缝车缝装置 Four-needle Flat Seaming

适用于一般内衣裤二片布接缝处的接缝和补强，附有专属的导边器，可使二片布顺畅缝合。

For flat seaming 2 pieces of fabrics on men's briefs, fabric guide included.

可自行组装 self-installation : YES

适用机型 applicable model : C007KP-W922



CX

环型平织松紧带包缝装置 Pneumatic Elastic Inserting

环型平织松紧带或蕾丝松紧带与衣物接缝，适用于男女内裤裤腰的松紧带缝合，配合右切刀修布装置更能提高缝制品质。

For tubular elastic or lace waistband attaching on men's or women's briefs, with right hand side fabric trimming to increase sewing quality and efficiency.

可自行组装 self-installation : YES

适用机型 applicable model : C007KP-W532,C007L-W532,C007L-U532



CZ

气动式环型罗纹松紧带包缝装置 Pneumatic Elastic Inserting

男女用内裤的裤头环型棉织松紧带的包缝，本装置需搭配CL及RLQ使用。

Attaching tubular elastic tape onto waistband, suitable for briefs. For using this device, CL and RLQ must be equipped together.

可自行组装 self-installation : YES

适用机型 applicable model : C007KP-W152



CZP

膝动式环型罗纹松紧带包缝装置 Manual Elastic Inserting

男女用内裤的裤头环型棉织松紧带的包缝，本装置需搭配CL及RLQ使用。

Attaching tubular elastic tape onto waistband, suitable for briefs. For using this device, CL and RLQ must be equipped together.

可自行组装 self-installation : YES

适用机型 applicable model : C007KP-W152



FA

侧向电动送带装置 Side Electric Tape Feeding

1. 利用电子微动开关控制布条，松紧带或蕾丝的输送长度，使上带车缝更加平顺。
2. 送带在控制箱右边。

1. With electronic switch to control the feeding length of tape, elastic, or lace to create smoother sewing.

2. Tape feeding will be on the right hand side of the control box.

可自行组装 self-installation : YES

适用机型 applicable model : C007KP/CQ, F007K/FQ, F007K/FFD,F007K/FFP, F007K/FSM, F007KD/FQ, F007KD/FFP

F□C 后切刀系列 Rear Cutter Series



FAC



FEC



FNC/FSC



FNC



FSC

	操作模式 Operation Mode	切刀驱动 Cutter Driven by	电眼 Sensor	抬压脚 Presser foot lifter	控制器 Controller	功能 Function
FAC	膝动 Knee	气缸 + 机械阀 (气动) Air cylinder + mechanical Valve (Pneumatic)	/	/	/	手动切刀 Manual Cutting
FEC	膝动 Knee	电磁铁 (电动) Solenoid (Electric)	/	/	FE201-A2 专用电控箱 Specific control box	手动切刀 Manual Cutting
FNC	自动/ 膝动 Auto/ Knee	气缸 + 电磁阀 (气动) Air cylinder + Solenoid (Pneumatic)	√	√	DFH608ADE-E 伺服马达驱动 Driven by servo motor	电眼侦测布边 (类似700QD/ECA) The sensor checks the cloth edge. (Similar to 700QD/ECA)
FSC	自动/ 膝动 Auto/ Knee	气缸 + 电磁阀 (气动) Air cylinder + Solenoid (Pneumatic)	√	√	DFH301NDD-E 伺服马达驱动 附触控面板 Driven by servo motor, with Control Panel	电眼侦测布边, 并且控制器以计数方式, 控制布带的松紧度与余留长度, 适用比基尼车缝 Checking the cloth edge by sensor, and also the metering device controls the tape tension and the remained length. Applicable to bikini sewing.

可自行组装 self-installation : NO

适用机型 applicable model : F007K/FQ, F007K/FE, F007K/SMK, F007K/STC, F007K/FR, F007K/FR/FQS,



FBP

裤耳车缝 Belt Loop Seaming

利用已裁好等宽的布条连续快速车缝裤耳

1. 一般W122机型可变换成FBP机型, 只需订购组件FBP- 256或FBP- 264, 便可换成车裤耳的功能。

2. 因所车缝布料不同而其所搭配的喇叭与针也会不同, 订购时请注明。

Mass production for belt loop by using stripped tape.

1. Normal W122 type can be changed to FBP type with FBP-256 or FBP-264 for belt loop seaming.

2. Different size folders and needles may be required depends on different fabric. Please refer to the below table and remark when ordering.

针距 Needle Gauge	成品尺寸 Finished Good	喇叭代号 Folder No.	布料 Fabric
5.6mm	9 mm	FBP01A	男女西服 Suits for Men & Women
5.6mm	10mm	FBP01B	
6.4mm	12mm	FBP01C	牛仔 Jeans

可自行组装 self-installation : YES

适用机型 applicable model : F007K-U613, F007KD-U613



FDC

拷克倒骨包缝装置 Covering Seaming

1. 适中厚至厚布料经四线拷克车包缝后的饰缝。
 2. 对于运动服等衣物领子、衣襟、袖管的拷边包缝后加以单面或双面装饰环缝，可增加服饰的美观及车缝的牢固。利用导布片及压具压刀的导缝，可避免车缝弯曲不直。
1. Overturned seam covering for medium to heavy fabric after 4 thread plain seaming.
 2. Suitable for neck openings, sleeve, cuff or bottom of sportswears, T-shirts, etc... With fabric guide and special presser foot making sewing easy and more efficient.

可自行组装 self-installation : YES

适用机型 applicable model : F007K-W322, F007KD-W322



FDE

拷克立骨包缝装置 Covering Seaming

1. 适用于中厚至厚布料经三线拷克车包缝后的饰缝。
 2. 对于运动服等衣物领子、衣襟、袖管的拷边包缝后加以单面或双面装饰环缝，可增加服饰的美观及车缝的牢固。利用导布片及压具压刀的导缝，可避免车缝弯曲不直。
1. Bulging seam covering for medium to heavy fabric after 3 thread plain seaming.
 2. Suitable for neck openings, sleeve, cuff or bottom of sportswears, T-shirts, etc... With fabric guide and special presser foot making sewing easy and more efficient.

可自行组装 self-installation : YES

适用机型 applicable model : F007K-W322, F007KD-W322



FE

电子式松紧带控制装置 Electric Type Elastic Feeding

1. 经由电子控制箱的数位设定，能有效控制松紧带在设定好的松紧度输送，以供车缝。
 2. 本装置可接受松紧带最大输送宽度为2-1/2"。
1. Elastic feeding ensures even length and elasticity, controlled by electronic digital control box.
 2. Maximum feeding width of elastic is 2-1/2".

可自行组装 self-installation : YES

适用机型 applicable model : F007K-W522, C007KP-W522



FFC

机械式松紧带控制装置 Mechanic Type Elastic Feeding

1. 经由机体内机械带动可自动输送松紧带，并经由齿轮箱控制器旋转钮，可依照衣服尺寸，微调设定车缝松紧带的松紧程度。
 2. 本装置可接受松紧带最大输送宽度为2-1/2"。
1. Elastic feeding ensures even length and elasticity controlled by gear set.
 2. Maximum feeding width of elastic is 2-1/2".

可自行组装 self-installation : No

适用机型 applicable model : F007K-W522, C007KP-W522



FFD

腰间或裤脚包缝控制松紧带前后车缝装置(机械式) Mechanic Type Elastic Feeding & Binding

1. 短裤及男女用内裤裤头或裤脚的松紧带包缝，利用无段变速控制器，可准确调整松紧带的松紧程度；运用操作简便的膝动控制系统，控制松紧带前后车缝，使车缝更完美。
 2. 本装置可接受松紧带最大的尺寸为1/8”到1/4”的宽度。
1. Elastic feeding ensures even length and elasticity controlled by gear set with elastic tape side-motion controller for sewing the beginning and ending of elastic tape onto waistband, leg opening of briefs, etc...
 2. Maximum width of elastic is 1/8" to 1/4".

可自行组装 self-installation : YES
 适用机型 applicable model : F007K-W222



FFP

腰间或裤脚包缝控制松紧带前后车缝装置(弹簧式) Mechanic Type Elastic Feeding & Binding (Leaf Spring)

1. 短裤及男女用内裤裤头或裤脚的松紧带包缝，利用无段变速控制器，可准确调整松紧带的松紧程度；运用操作简便的膝动控制系统，控制松紧带前后车缝，使车缝更完美。
 2. 本装置可接受松紧带最大的尺寸为1/8”到1/4”的宽度。
1. Elastic feeding ensures even length and elasticity controlled by leaf spring with elastic tape side-motion controller for sewing the beginning and ending of elastic tape onto waistband, leg opening of briefs, etc...
 2. Maximum width of elastic is 1/8" to 1/4".

可自行组装 self-installation : YES
 适用机型 applicable model : F007K-W222, F007KD-W222



FH

下固定式送带盘 Lower Fixed Tape Holder

置于桌下方放布条或松紧带。
 Holds tape or elastic tape under the table.

可自行组装 self-installation : YES
 适用机型 applicable model : C007L/CFC, C007KP/CFC



FHA

下摆车缝 Hemming

T恤、内衣、儿童服饰的下摆车缝；可随需要调整下摆宽度，操作简单。
 Suitable for bottom hemming of T-shirts, underwears, cuff of children's garments, etc... Able to adjust the width of hemming set to meet different demands, easy operation.

可自行组装 self-installation : YES
 适用机型 applicable model : F007K-W121, F007K-W122, F007K-W123, F007K-W162
 F007KD-W121, F007KD-W122, F007KD-W123, F007KD-W162



FL

后拉滚轮装置 Rear Puller

适用于薄到中厚布车缝如：床单、被套、毛巾等（较厚的硬滑布类不可适用），另附一组可调式下摆车缝组FHA（K）。

Suitable for light to medium fabric, such as bedsheets, quilts, towels etc. With one set of adjustable bottom hemming device, FHA(K). (not suitable for the hard and slip fabric which is much heavy)

可自行组装 self-installation : NO
 适用机型 applicable model : F007K-W121/FHA, F007K-W122/FHA, F007K-W123/FHA,
 F007K-W162/FHA, F007K-W222/FQ
 F007KD-W121/FHA, F007KD-W122/FHA, F007KD-W123/FHA,
 F007KD-W162/FHA, F007KD-W222/FQ



FP

折线条装置 Crinkle Seaming

运动服装，牛仔服饰或其他服饰的凸面折线条车缝，车缝时可于折线条内另加缝线绳，以增加凸线条的立体感和装饰效果。

To sew a decorative convex stripe on sportswears, jeans or other clothes, can also add extra stripe inside convex to increase the effects of convexity and decoration.

可自行组装 self-installation : YES

适用机型 applicable model : F007K-U122-232, F007KD-U122-232



FQ

上带滚边车缝 Tape Binding

1. T恤、内衣裤、儿童服饰等的衬带或包边车缝。
2. 本装置与机器一起订购时会加附FG组，但个别购买FQ元件时则不另附FG组。
3. 喇叭标准规格为人布宽度1-3/8”，出布宽度为1/2”，卷成三折，若需要标准品以外的尺寸，请订购时特别注明，但交期和费用另计。
4. 本装置有三种订购方式：

1. For tape binding on openings of leg or underwear, T-shirt, etc...
2. If purchased machine with FQ, we will also attach FG. If purchase FQ device only, no FG attached.
3. Binder's standard opening size is 1-3/8" wide and finished size is 1/2" wide in 3 folds. Please remark if need another size when ordering, delivery date and cost will be re-calculated.
4. Ways to order the device:

机型 Model	FQ	FG	FQ 规格组 FQ Gauge Set	喇叭 Binder
F007K-W222-240/FQ	√	√	√	√
F007K-W222-240	×	×	√	×
F007K-W222-240/FQP	√	√	√	×

可自行组装 self-installation : YES

适用机型 applicable model : F007K-W222, F007KD-W222



FR

右切刀装置 Right Side Fabric Trimmer

修齐两片布接缝的下方多余的布料，使车缝品质更加美观。

Right hand side waste fabric trimming, ensures better sewing quality.

可自行组装 self-installation : NO

适用机型 applicable model : F007K-W522



FSM

花饰滚边车缝 Ornamental Tape Binding

适用于T恤衫、衬衫等领口及下摆、袖口等花饰滚边车缝，附有四组花饰凸轮可变化成数百种车缝花样。

Suitable for ornamental tape binding of neck band, bottom or cuff of T-shirts, shirts, etc... Four sets of cam create hundreds of patterns.

可自行组装 self-installation : NO

适用机型 applicable model : F007K-W222, F007KD-W222



FSP

双勾针上布条装置 Double Looper Tape Binding

双针双勾针布条贴缝装置，例如男内裤门襟。

This device is specially designed for tape binding on cross seaming of men's briefs or sportswears.

压具代码 Presser Foot Code	入布宽度 Tape Width	出布宽度 Finish Width	适用机型 Applicable Model
P5118 (含喇叭) P5118 (binder included)	25mm	12mm	F007K(D)-U712A
P5117 (含喇叭) P5117 (binder included)	21mm	10mm	F007K(D)-U712

可自行组装 self-installation : NO

适用机型 applicable model : F007K-U712, F007KD-U712



FSR

卷叠缝 Lap Seaming

本机种设计特殊的左右齿差动方式，能使卷叠缝缝纫更顺畅，车缝后左右两片均一无长短的虞；适用于西裤、休闲裤、牛仔裤薄至厚布料等的卷边叠缝。

Differential ratio of left and right feed dog can be adjusted separately for lap seaming to ensure symmetrical length to both left and right fabric. Applicable to trousers, casual pants and jeans, etc...

可自行组装 self-installation : NO

适用机型 applicable model : F007K-U712, F007KD-U712



FW



FWP

四针六线环缝车缝装置 Four-needle Flat Seaming

用于一般内衣裤二片布接缝处的接缝和补强，无需先经由拷克车拷边再饰缝，牢固美观，可附加喇叭（B417R）做贴带补强用组件代号FWP。

For flat seaming 2 pieces of fabric, equipped with fabric guide for easy operation.

FWP: Folder(B417R) is optional, for tape attaching.

可自行组装 self-installation : NO

适用机型 applicable model : F007K-W922, F007KD-W922



FY

裤袋里布车缝 Pocket Lining Seaming

用于裤袋的缝制，三针三勾一上叉针可强化缝合，增加产品的牢固。西服、工作服等衣袋和裤袋内里的缝纫工程。

This is a 3 needles 3 loopers 1 spreader machine, and special for seaming the shell fabric and lining of pocket in trousers or working pants in simple operation to increase sewing quality and efficiency.

可自行组装 self-installation : NO

适用机型 applicable model : F007K-W722, F007KD-W722



LFA

直向电动送带装置 Electric Tape Feeding Device

利用电子马达带动松紧带，使其放松到零松紧状况，并可控制所需松紧带的长短，使车缝时松紧度能一致。

电压：110V(Part NO. LFA-1A) / 220V(Part NO. LFA-2A)

Elastic type is fed by electric motor to achieve zero tension. Elastic tape length can be easily adjusted to expect length to ensure elasticity consistency.

Voltage, 110V(Part NO. LFA-1A) / 220V(Part NO. LFA-2A)

可自行组装 self-installation : YES

适用机型 applicable model :

C007KP/FE, C007KP/FFC, C007KP/CR/FE, C007KP/CR/FFC, F007K/FE, F007K/FFC, F007K/FFD, F007K/FFP, F007K/FSP, F007K/FBP, F007K/FWP, F007K/FR/FE, F007K/FR/FFC, F007KD/FE, F007KD/FFP, F007KD/FSP, F007KD/FBP, F007KD/FWP



LF290

抖带轮 Untangling Wheel

可选配安装于LFA (送带装置)，以逆转的方式，抖动松紧带，做为送带前的处理。

电压：110V(Part NO. LF290-A1) / 220V(Part NO. LF290-A2)

An optional device to be equipped with LFA (tape feeding device). Untangling the elastic tape by reverse rotation wheel is a pre-feeding process.

Voltage, 110V(Part NO. LF290-A1) / 220V(Part NO. LF290-A2)

可自行组装 self-installation : YES

适用机型 applicable model : MODEL w/LFA



LS-A

上方带盘 Upper Tape Holder

置于上前方放布条或松紧带。

For top feeding tape or elastic.

可自行组装 self-installation : YES

适用机型 applicable model :

C007KP/FE, C007KP/FFC, C007KP/CR/FE, C007KP/CR/FFC, F007K/FE, F007K/FFC, F007K/FFD, F007K/FFP, F007K/FSP, F007K/FBP, F007K/FWP, F007K/FR/FE, F007K/FR/FFC, F007KD/FE, F007KD/FFP, F007KD/FSP, F007KD/FBP, F007KD/FWP



PCC

拷克倒骨盖缝装置 Overlock-Seam Covering (Fold-down Type)

1. 适中厚至厚布料经四线拷克车包缝后的饰缝。

2. 对于运动服、领子、衣襟、袖管的拷边车缝后加以单面或双面装饰环缝，可增加服饰的美观及车缝的牢固。利用导布片及压具上的压刀导缝，可避免车缝时弯曲不直。

1. Overturned seam covering for medium to heavy fabric after 4 thread plain seaming.

2. Suitable for neck openings, sleeve, cuff or bottom of sportswears, T-shirts, etc...

With fabric guide and special presser foot, making sewing easy and more efficient.

可自行组装 self-installation : YES

适用机型 applicable model : S007K all models, S007KD all models



PCE

拷克立骨盖缝装置 Overlock-seam Covering (Flattening Type)

1. 适中厚布料经三线拷克车包缝后的饰缝。

2. 对于运动服，领子，衣襟，袖管的拷边车缝后加以单面或双面装饰环缝，可增加服饰的美观及车缝的牢固。利用导布片及压具上的压刀导缝，可避免车缝弯曲不直。

1. Bulging seam covering for medium fabric after 3 thread plain seaming.

2. Suitable for neck openings, sleeve, cuff or bottom of sportswears, T-shirts, etc...

With fabric guide and special presser foot making sewing easy and more efficient.

可自行组装 self-installation : YES

适用机型 applicable model : S007K all models, S007KD all models



PCH

下摆车缝 Bottom Hemming

T恤、内衣及儿童服饰下摆及袖口的车缝，可随需要调整下摆饰缝组宽度，操作简单快捷。

Suitable for the bottom hemming of T-shirts, underwears, cuff of children's garments, etc...
Able to adjust the width of hemming set to fit demands, easy operation.

可自行组装 self-installation : YES

适用机型 applicable model : S007K all models, S007KD all models



RL

筒型衣物撑开滚轮组(长轮) Tubular Extending Roller (Long Type)

专用于辅助筒型衣物的车缝。

Especially used to assist with tubular cloth sewing.

可自行组装 self-installation : YES

适用机型 applicable model : C007KP/CY, C007L



RLP1

筒型衣物撑开滚轮组(短轮+斜轮) Tubular Extending Roller (Short+ Cone Type)

专用于辅助筒型衣物的车缝。

Especially used to assist with tubular cloth sewing.

可自行组装 self-installation : YES

适用机型 applicable model : C007KP/CX



RLQ

筒型衣物撑开滚轮组 Tubular Extending Roller

专用于辅助筒型衣物的车缝。

Especially used to assist with tubular cloth sewing.

可自行组装 self-installation : YES

适用机型 applicable model : C007KP/CZ

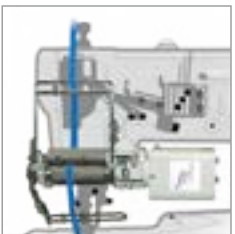

SMK

电子计数式送带 Electric Metering type tape feeding

SMK1 - □ - □

- A: 包缝机, 上送带
Overlock, Top Feed
- C: 绷缝机, 上送带
Interlock, Top Feed
- D: 绷缝机, 下送带
Interlock, Bottom Feed
- E: 绷缝机, 侧送带
Interlock, Side Feed

- 01 附定位器, 适合简易伺服或离合器马达
With synchronizer for simple servo motor or clutch motor
- 02 以中继线, 连接伺服马达
Connected to servo motor by encoder cable

可自行组装 self-installation : YES

适用机型 applicable model : C007KP/CR, F007/CR



SRL

左切刀装置(小筒用) Left Side Fabric Trimmer (For Small Cylinder Bed)

修齐两片布接缝左下方多余的布料，使车缝后更加整齐美观。
Left edge trimmer makes fabric edge aligned to seam.

可自行组装 self-installation : NO
适用机型 applicable model : S007KD-812



STC

张力控制式送带 Tension sensor type tape feeding

STC1 - □ - □

U: 上送带
Top Feed
B: 下送带
Bottom Feed
S: 侧送带
Side Feed

01 附定位器，适合简易伺服或离合器马达 With synchronizer for simple servo motor or clutch motor
02 以中继线，连接伺服马达
Connected to servo motor by encoder cable

可自行组装 self-installation : YES
适用机型 applicable model : C007KP/CR, F007/CR

UT 自动切线组 Automatic Thread Trimmer Set



上切
Top Trimmer



下切
Bottom Trimmer



夹线
Thread Gripper



吹风
Thread Blowing



机型 Model	代号 Code	功能 Function				驱动 Drive	
		上切 Top Trimmer	下切 Bottom Trimmer	夹线 Thread Gripping	吹风 Thread Blowing	气动 Pneumatic	电动 Electronical
F007K F007KD	UTG	√	√		*	√	
	UTH		√	选配 Optional	√		
	UTJ	√	√				√
	UTK		√	√			
C007KP C007L	UTP	√	√		*	√	
	UTQ		√	选配 Optional	√		
	UTR	√	√				√
	UTS		√	√			
S007K S007KD U007	UTT	√	√		*	√	
	UTU		√	选配 Optional	√		
	UTX	√	√				√
	UTY		√	√			

*配件盒附吹风管，客户若不需上网线时，可自行将上切刀改为吹风。

Thread blowing device is included in the accessory box. If the coverstich thread is not required, users may install blowing device instead of upper thread trimmer.

DC 下轴型直驱伺服马达 Lower main shaft type direct drive servo motor

DCL H D 1 - 1

① ② ③ ④ ⑤

- ① 机种别 Model
DFK : F007K
DCK : C007KP
DCL : C007L
DSK : S007K
- ② 系列别 Motor Series
H : H系列马达电控系统
H-Series motor
U : U系列马达电控系统
U-Series motor
- ③ 认证项目 Certification
空白 : CE认证
none : CE Certification
D : 巴西认证
D : Brazil Certification
- ④ 代别 Version
1 : 第一代 first version
- ⑤ 功能别 Funtion
0 : 简易型 (针上/下定针) Simple type (needle position function)
1 : 气动式多功能型 Pneumatic, Multi-functional
2 : 电动式多功能型 Electric, Multi-functional

直驱电控箱组 Direct drive electric control box set		配件表 Accessories list																	
		UTG	UTH	UTJ	UTK	FSC	UTP	UTQ	UTR	UTS	CAR	CR	CRL	UTT	UTU	UTX	UTY	SAR	CAF
F007K	DFKH③④-1	●	●			●													●
	DFKH③④-2			●	●														
C007KP	DCKH③④-1						●	●			●	●	●						●
	DCKH③④-2							●	●										
C007L	DCLH③④-1						●	●			●	●							●
	DCLH③④-2							●	●										
S007K	DSKH③④-1													●	●			●	●
	DSKH③④-2															●	●		
U007	DUKH③④-1													●	●				
	DUKH③④-2															●	●		
F007K	DFKU③④-0	(此型号配件表未完全列出)																	
	DFKU③④-1	●	●																●
	DFKU③④-2			●	●														
C007KP	DCKU③④-0	(此型号配件表未完全列出)																	
	DCKU③④-1						●	●											●
	DCKU③④-2							●	●										
C007L	DCLU③④-0	(此型号配件表未完全列出)																	
S007K	DSKU③④-0	(此型号配件表未完全列出)																	

TABLE

桌板代号 Item No.	尺寸 / Size (mm)			说明 Description	适用机型 Applicable Model	备注 Remark
	长 Length	宽 Width	厚 Thickness			
C007L-T23	1200	540	45	半沉式 Semi-submerged	C007L, C007LD, C007LX	
C007L-T25	1200	540	45	上乘式 Non-submerged	C007L, C007LD, C007LX	
C007L-T26	1200	540	45	半沉式 Semi-submerged	C007L/CFC	
C007L-T30	1200	540	45	上乘式 Non-submerged	C007LD	
C007K-T23	1200	540	45	半沉式 Semi-submerged	C007K, C007KD, C007KP, C007JP, S007K, S007KD, U007	
C007K-T25	1200	540	45	上乘式 Non-submerged	C007K, C007KD, C007KP, C007JP, S007K, S007KD, U007	
C007K-T26	1200	540	45	半沉式 Semi-submerged	C007K/CFC, C007KP/CFC	
C007-T30	1200	540	45	上乘式 Non-submerged	C007K, C007KP, C007JP, S007K, U007	
C007K-T32	1200	540	45	上乘式 Non-submerged	C007K, C007KP, C007JP, S007K, U007 for SILMAQ	
C007K-T33	1200	540	45	上乘式 Non-submerged	C007K, C007KP, C007JP, S007K, U007 DD Motor Model for SILMAQ	
C007KP-T25	1200	540	45	上乘式 Non-submerged	C007KP for CR, CRL, UT	搭桌板散热风扇 Table board cooling fan
F007K-T	1200	540	45	半沉式 Semi-submerged	F007K	
F007K-T1	1200	540	45	半沉式 Semi-submerged	F007K/FR	
F007K-T3	1200	540	45	全沉式 Fully-submerged	F007K	
F007K-T4	1200	540	45	半沉式 Semi-submerged	F007KD	
F007K-T5	1200	540	45	半沉式 Semi-submerged	F007KD/FR	
F007KD-T3	1200	540	45	全沉式 Fully-submerged	F007KD	
S007-T3	1200	540	45	半沉式 Semi-submerged	S007K/SRL, S007KD/SRL	

DOUBLE CHAINSTITCH MACHINE

VC008A

-

04

064

P

/

VCE

针数
Needle Numbers

后拉引滚轮
Rear Pullers

配件
Device

机种别 Model

VC008A 筒型多针缝纫机(高贯穿力型)
Multineedle Cylinder Bed Double Chainstitch
Machine (High Penetration Power Type)

VC008B 筒型多针缝纫机(4~6针高速型)
Multineedle Cylinder Bed Double Chainstitch
Machine (4~6 Needles High Speed Type)

HF008A 平台型牛仔用二重环缝纫机
Flat Bed Double Chainstitch Machine for
Jeans

NC008 针送牛仔裤腰车
Needle Feed Cylinder Bed Double
Chainstitch Machine for Jeans Waistband

等距针距

Equal Distance Between Needles

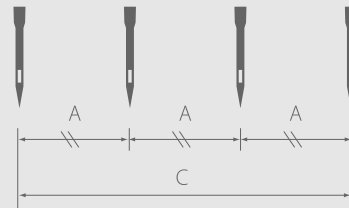

不等距

Unequal Distance Between Needles

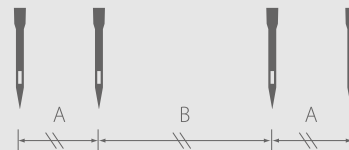

DOUBLE CHAINSTITCH DD SERVO MOTOR

VC008A - 04085P / VWLB / FH / DV□□

DV□□ VC008A/B, HF008A, NC008型直驱电控组
Direct Drive Servo Motor for VC008A/B, HF008A,
NC008

VC008A / B SERIES FEATURES



VC008A

筒型多针缝纫机(高贯穿力型)

Multineedle Cylinder Bed Double Chainstitch Machine (High Penetration Power Type)



全自动供油，勾针纵向运动机构，多针双重链式缝

Automatic lubrication system, vertical looper mechanism, multineedle chainstitch mechanism.



采用独立勾针座，可变化不同的针位元组合，达到一机多用的功能（选配）

Using independent looper holder and can easily change different needle position, Multi-function machine design.(optional)



筒型机身设计，方便环型衣物缝纫

Cylinder machine frame design, easy sewing operation for circular cloth.



按钮式缝距调整模式，调整简便快速

Stitch length adjustment by knob, easy and fast.



左侧附一辅助设计，拉布稳定，出布更顺畅，维护便利

Using one supportive puller on left side which can stabilize the pulling and sewing process.



适用于多种工序的缝纫，适合针织类高级衣物的装饰车缝

Suitable for multi sewing process, high quality knit material and decorative sewing.



新型轴承式滚轮，缝制时拉布与出布更顺畅稳定

New bearing type rear puller handles the material with better stability.

VC008B

筒型多针缝纫机 (4~6针高速型)

Multineedle Cylinder Bed Double Chainstitch Machine (4~6 Needles High Speed Type)



使用皮带传动来驱动上下轴，实现高速稳定的缝制

New mechanism uses the belt to drive both upper and lower shaft, provides faster and more stable sewing experience.





平顺且低振动，车缝薄料得心应手

High performance with thin material, less vibration and smoother movement.



新型轴承式滚轮，缝制时拉布与出布更顺畅稳定

New bearing type rear puller handles the material with better stability.

	1.4-3.6		12		UOX113GS #11~#14		S.P.M. (Max)	4500
--	---------	---	----	---	---------------------	---	-----------------	------

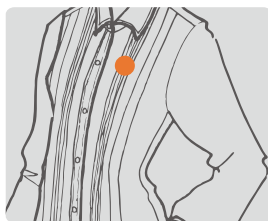

4针机型

4-Needle type

VC008A-04XXX
VC008A-04XXX-XXX

12针机型

12-Needle type

VC008A-12XXX
VC008A-12XXX-XXX
VC008A-13XXX
VC008A-13XXX-XXX
VC008A-17XXX
VC008A-21XXX
VC008A-23XXX



一般平缝

全自动给油，勾针纵向运动机构，筒型车台，利于圆筒型衣物的缝纫，适用于一般高级衣物的装饰车缝。

GENERAL SEAMING

Cylinder bed automatic oiling, back and forth loopers driving mechanism, suitable for decorative sewing on high quality dress or tubular goods.

V2 Device

Model	Specification					2.5-5		12		UOX113GS #11~#14		S.P.M. (Max)	4000	Remark																										
															每单位 (Unit)=1.6mm=1/16"																									
<table border="1" style="width:100%; text-align:center; font-size:small;"> <tr> <td>26</td><td>24</td><td>22</td><td>20</td><td>18</td><td>16</td><td>14</td><td>12</td><td>10</td><td>8</td><td>6</td><td>4</td><td>2</td><td>2</td><td>4</td><td>6</td><td>8</td><td>10</td><td>12</td><td>14</td><td>16</td><td>18</td><td>20</td><td>22</td><td>24</td><td>26</td> </tr> </table>															26	24	22	20	18	16	14	12	10	8	6	4	2	2	4	6	8	10	12	14	16	18	20	22	24	26
26	24	22	20	18	16	14	12	10	8	6	4	2	2	4	6	8	10	12	14	16	18	20	22	24	26															
VC008A-	1132-064P	11	22	(1/8-1/4-1/8") (3.2-6.4-3.2mm)																																				

[三合一] 裤头车缝

本机型适用松紧带皱折型、平坦型、薄牛仔，可以弹性组合出各种常用的4针针位组如1/4-1/4-1/4, 1/4-3/4-1/4...等。

[3 in 1] WAIST BAND SEWING

This model is applicable to elastic band wrinkled type, flat type, light denim, which offers various 4-needle gauges by one set.
E.g.: 1/4-1/4-1/4, 1/4-3/4-1/4...etc.



选购配件 OPTIONAL DEVICE
VCE

	VCL08S	细齿上拉轮 (钢质), 薄牛仔 Fine teeth type upper puller (steel).light denim.
	VCL16P VCL28	平轮组 (PU 材质) Flat type puller set (PU)
	P9211A-A	二段式压脚 Two-piece type presser foot

V3 Device

				mm	mm	mm	Needle No.	S.P.M. (Max)
VC008A- VC008B-	04064P/VCE	4	8	1/4"(6.4mm)	1.4~3.6	12	UOX113GS #11~#14	4000
	04085P/VCE	4	8	1/3"(8.5mm)	1.4~3.6	12	UOX113GS #11~#14	4000
	04095P/VCE	4	8	3/8"(9.5mm)	1.4~3.6	12	UOX113GS #11~#14	4000
	04106P/VCE	4	8	5/12"(10.6mm)	1.4~3.6	12	UOX113GS #11~#14	4000
	04127P/VCE	4	8	1/2"(12.7mm)	1.4~3.6	12	UOX113GS #11~#14	4000



VC008B-04064P/VCE

裤头松紧带车缝

用于运动裤或运动短裤等圆筒型衣裤腰部松紧带的包缝，本机型可有两种缝合的方式：
(1)环型松紧带布料折边缝 (2)拷克后上环型松紧带包缝

ELASTIC INSERTING / ATTACHING

Inserting and attaching elastic on waistband of jogging suits, sportswears or shirts etc., two types of sewing functions are available :

1. To attach tubular seamless elastic waistband.
2. To cover sewing on elastic after overlock seaming.

选购配件	OPTIONAL DEVICE
	VAD , RL

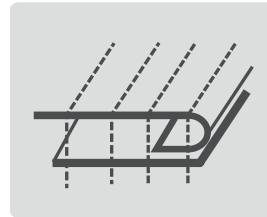
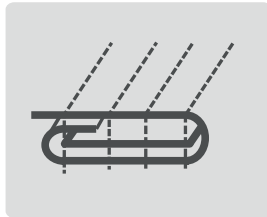

V4 Device

				mm	mm	mm	Needle No.	S.P.M. (Max)
VC008A-	04064P/VWL	4	8	1/4"(6.4mm)	1.4~3.6	12	UOX113GS #11~#14	4000
	04085P/VWL	4	8	1/3"(8.5mm)	1.4~3.6	12	UOX113GS #11~#14	4000
	04095P/VWL	4	8	3/8"(9.5mm)	1.4~3.6	12	UOX113GS #11~#14	4000
	04106P/VWL	4	8	5/12"(10.6mm)	1.4~3.6	12	UOX113GS #11~#14	4000
	04127P/VWL	4	8	1/2"(12.7mm)	1.4~3.6	12	UOX113GS #11~#14	4000

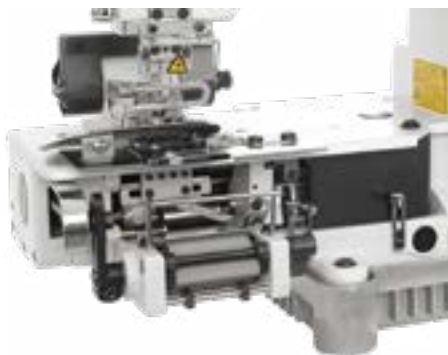

VC008A-04085P/VWL

裤头松紧带车缝 (附B413喇叭)

松紧带送带滚轮装置能依据机台的运转速度送带，可准确控制松紧带长度与松紧度，操作简便，适用于慢跑裤、运动裤、男女内裤等裤头的松紧带车缝。

注：B413喇叭可用松紧带尺寸为 38mm

ELASTIC ATTACHING (WITH FOLDER B413)

Elasticity and length feeding can be accurately controlled according to sewing speed of machine. Easy operation for elastic inserting and attaching on waistband of jogging pants, sportswears, briefs etc.

Remark : Elastic size 38mm for folder B413

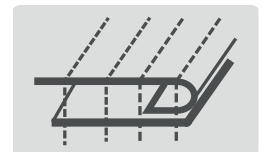

选购配件	OPTIONAL DEVICE
	FH

V5 Device

							Needle No.	
VC008A-	04064P/VWLB	4	8	1/4"(6.4mm)	1.4~3.6	12	UOX113GS #11~#14	4000
	04085P/VWLB	4	8	1/3"(8.5mm)	1.4~3.6	12	UOX113GS #11~#14	4000
	04095P/VWLB	4	8	3/8"(9.5mm)	1.4~3.6	12	UOX113GS #11~#14	4000
	04106P/VWLB	4	8	5/12"(10.6mm)	1.4~3.6	12	UOX113GS #11~#14	4000
	04127P/VWLB	4	8	1/2"(12.7mm)	1.4~3.6	12	UOX113GS #11~#14	4000

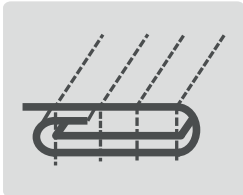

裤头松紧带车缝 (附B411喇叭及撑开滚轮组)

松紧带送带滚轮装置能依据机台的运转速度送带，可准确控制松紧带长度与松紧度，操作简便，适用于慢跑裤、运动裤、男女内裤等裤头的松紧带车缝。

ELASTIC INSERTING (WITH FOLDER B411 AND EXTENDING ROLLER)







Elasticity and length feeding can be accurately controlled according to sewing speed of machine. Easy operation for elastic inserting and attaching on waistband of jogging pants, sportswears, briefs etc.

喇叭尺寸 Folder Size	成品尺寸 Finished Size	松紧带尺寸 Elastic Tape Size	适用机型 Applicable Model
B411	33 mm	31 mm	04095
B411P	30 mm	28 mm	04085
B411Q	42 mm	40 mm	04127
B411R	25 mm	23 mm	04064
B411S	36 mm	34 mm	04106

选购配件 OPTIONAL DEVICE

FH

V6 Device

							Needle No.	
VC008A-	04064P/VWLC	4	8	1/4"(6.4mm)	1.4~3.6	12	UOX113GS #11~#14	4000
	04085P/VWLC	4	8	1/3"(8.5mm)	1.4~3.6	12	UOX113GS #11~#14	4000
	04095P/VWLC	4	8	3/8"(9.5mm)	1.4~3.6	12	UOX113GS #11~#14	4000
	04106P/VWLC	4	8	5/12"(10.6mm)	1.4~3.6	12	UOX113GS #11~#14	4000
	04127P/VWLC	4	8	1/2"(12.7mm)	1.4~3.6	12	UOX113GS #11~#14	4000
	12048P/VWLC	12	24	3/16"(4.8mm)	1.4~3.6	12	UOX113GS #11~#14	4000
	12064P/VWLC	12	24	1/4"(6.4mm)	1.4~3.6	12	UOX113GS #11~#14	4000

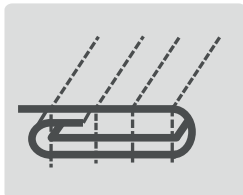

裤头松紧带车缝 (附VCE导片)

松紧带送带滚轮装置能依据机台的运转速度送带，可准确控制松紧带长度与松紧度，操作简便，适用于慢跑裤、运动裤、男女内裤等裤头的松紧带车缝。

ELASTIC INSERTING /ATTACHING (WITH VCE FABRIC GUIDE)



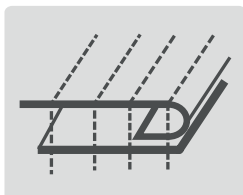



Elasticity and length feeding can be accurately controlled according to sewing speed of machine. Easy operation for elastic inserting and attaching on waistband of jogging pants, sportswears, briefs etc.



选购配件 OPTIONAL DEVICE

FH

V7  Device

								
VC008A-	06048P/VPL	6	12	3/16"(4.8mm)	1.4~3.6	12	UOX113GS #11~#14	4000
VC008B-	06064P/VPL	6	12	1/4"(6.4mm)	1.4~3.6	12	UOX113GS #11~#14	4000



VC008B-06064P/VPL

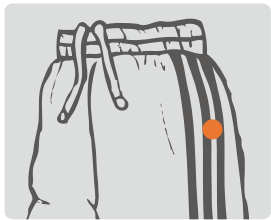

上带车缝

适用于装饰条带、运动衣裤等车缝，效率高、品质稳定。

TAPE ATTACHING







Suitable for attaching ornament tape on sportswears.
For high efficiency and perfect quality sewing.

选购配件 OPTIONAL DEVICE
LSA

若需要更高阶机型，请参考
ASV-ATS100A (P.16)
For advanced model, please
refer to ASV-ATS100 (P.16)



V8  Device

								
VC008A-	12048P/VPQ	12	24	3/16"(4.8mm)	1.4~3.6	12	UOX113GS #11~#14	4000
	12064P/VPQ	12	24	1/4"(6.4mm)	1.4~3.6	12	UOX113GS #11~#14	4000



VC008A-12064P/VPQ

松紧带抽皱缝装置

适用于女皱折连身衣裙等腰边松紧线皱折，如女用衬衫，游泳衣，枕头套，儿童衫等
均能车缝顺畅。

注：勾针底线宜用弹性线





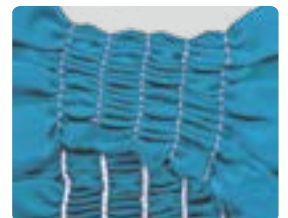
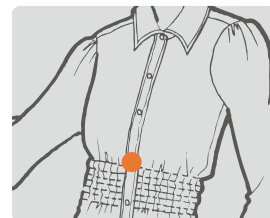

ELASTIC THREAD SHIRRING SEWING

Suitable for sewing ornamental shirring with elastic thread on women's blouses,
swimsuits, dresses, pillowcases, and children's shirts etc.

Remark : Suggested to use elastic thread for lower looper



V9 Device

							Needle No.	
VC008A-	12048P/VPQ-K	12	24	3/16"(4.8mm)	1.4~3.6	12	UOX113GS #11~#14	4000
	12064P/VPQ-K	12	24	1/4"(6.4mm)	1.4~3.6	12	UOX113GS #11~#14	4000



VC008A-12048P/VPQ-K

松紧带抽皱缝装置

适用于女皱折连身衣裙等腰边松紧线皱折，如女用衬衫，游泳衣，枕头套，儿童衫等均能车缝顺畅。

注：

1. 勾针底线宜用弹性线。
2. 增加VWL组可稳定弹性线的松紧度让车缝更平顺美观，不跳针。
3. 将弹性线安装于桌板下，让弹性线车缝更顺畅。
4. 本机为多功能车，可调为VWL，VPQ或一般车使用。

ELASTIC THREAD SHIRRING SEWING





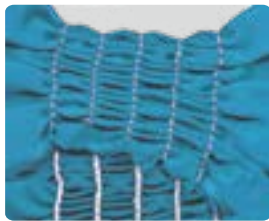
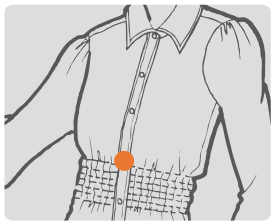

Suitable for sewing ornamental shirring with elastic thread on women's blouses, swimsuits, dresses, pillowcases, and children's shirts etc.

Remark :

1. Suggested to use elastic thread for lower looper.
2. The added VWL set will further stabilize the tension of elastic thread and make sewing process more smoothly, also can avoid stitch skipping.
3. Holds the elastic thread under the table to make sewing process more smoothly.
4. This is a multifunctional machine, can easily adjust to VWL, VPQ, or standard machine.



V10 Device

							Needle No.	
VC008A-	12048P/VPS	12	12	3/16"(4.8mm)	1.4~3.6	12	DV-K25 #18~21	4000
	12064P/VPS	12	12	1/4"(6.4mm)	1.4~3.6	12	DV-K25 #18~21	4000



VC008A-12064P/VPS

松紧带抽皱缝装置

适用于女皱折连身衣裙等腰边松紧线皱折，如女用衬衫、游泳衣、枕头套、儿童衫等均能车缝顺畅。

注:针线用弹性线，以勾针为勾线功能不穿线，为101车缝式样





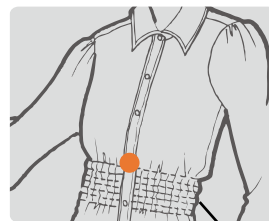

ELASTIC THREAD SHIRRING SEWING

Suitable for sewing ornamental shirring with elastic thread on women's blouses, swimsuits, dresses, pillowcases, and children's shirts etc.

Remark : Needle uses elastic thread and looper without thread. It's 101 sewing type.



V11  Device

				 mm	 mm	 mm	Needle No.	 S.P.M. (Max)
VC008A-	04A64-191P/VSF	4	8	1/4-3/4-1/4" (6.4-19.1-6.4mm)	1.4~3.6	12	UOX113GS #11~#14	4000
	04A64-254P/VSF	4	8	1/4-1-1/4" (6.4-25.4-6.4mm)	1.4~3.6	12	UOX113GS #11~#14	4000



VC008A-04A64-254P/VSF

衬衫门襟车缝

适宜各种四针或二针的衬衫门襟车缝，由于加装喇叭使在一个工序即可完成车缝，另可选择不同的喇叭做不同的车缝样式。





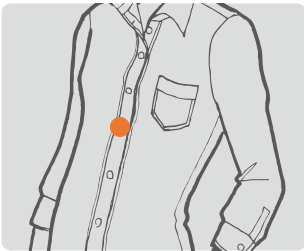

SHIRT-FRONTING ATTACHING

With a special folder to sew on 2 or 4 needled shirt fronting, complete in one simple sewing operation. Also available are the various folders for different sewing style.



选购配件	OPTIONAL DEVICE
	LSA

V12  Device

				 mm	 mm	 mm	Needle No.	 S.P.M. (Max)
VC008A-	12048P/VSC	12	36	3/16"(4.8mm)	1.4~3.6	12	UOX113GS #11~#14	2500
	12064P/VSC	12	36	1/4"(6.4mm)	1.4~3.6	12	UOX113GS #11~#14	2500



VC008A-12064P/VSC

松紧带抽皱缝装置

弹性线直送不打线圈，由针线与勾针线上下包覆，车缝成品效果较VPQ薄，且皱折可拉伸至完全平坦。

ELASTIC THREAD SHIRRING SEWING

Elastic thread is straight, not looped, which is fixed by needle thread and looper thread. The finish is thinner than VPQ and the shirring becomes flat as it is pulled extensively.

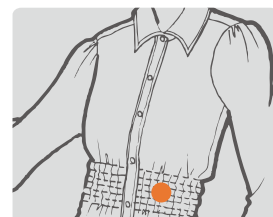

HF008A SERIES FEATURES

HF008A

平台型牛仔用二重环缝纫机 Flat Bed Double Chainstitch Machine for Jeans



精心设计的供油系统及零配件精度加工，延长机器使用寿命

Using unique design of lubrication system and attachments to extend the machine lifetime.



按钮式缝距调节，可适合多品种生产

Stitch length adjustment by knob, suitable for all different kinds of materials.



上、下滚轮的双重配合使出布更顺畅

Upper and lower puller design to make sewing process more stable.



HF008A-03XXX-XXX

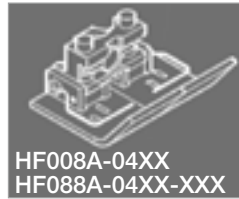
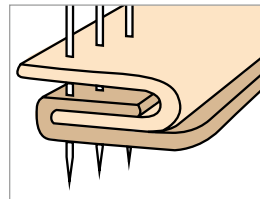

HF008A-04XX
HF088A-04XX-XXX

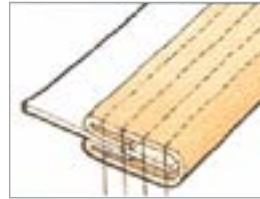

适用工作服、牛仔裤的搭缝(埋夹缝)与裤头车缝

Suitable for tape binding on waistband of workwear pants, jeans.

H1 Device

	2	4	1/4"(6.4mm)	1.8~3.6	12	UYX128GAS#14~#16	4200	
HF008A-02064P/HHD	2	4	1/4"(6.4mm)	1.8~3.6	12	UYX128GAS#14~#16	4200	
HF008A-03064P/HHD	3	6	1/4"(6.4mm)	1.8~3.6	12	UYX128GAS#14~#16	4200	



HF008A-02064P/HHD



埋夹缝

适用于薄至厚料如工作服、牛仔裤的搭缝。

注：一般出车，均不附喇叭，如有需要可依以上规格订制

LAP SEAMING

To lap seaming on light to heavy material such as workweares or jeans, etc...

Remark : Folder is not included. Please specify folder no. when ordering.

可选择的规格 Available Model		布料 Material	喇叭代号 Folder No.
02064/HHD 03064/HHD	1/4"	薄料 light	B511
		中厚料 medium	B511P
		厚料 heavy	B511Q

H2 Device

HF008A-03064P/HTF	3	6	1/4"(6.4mm)	1.8~3.6	12	TVX5 #18~#21	4200
-------------------	---	---	-------------	---------	----	--------------	------



HF008A-03064P/HTF

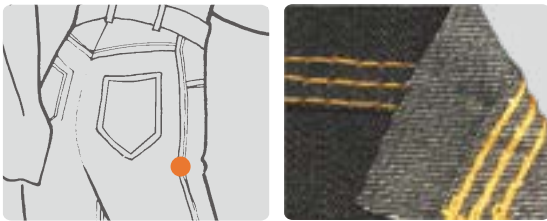

搭缝

适用于中厚布料至极厚布料如工作服、牛仔裤等粗斜纹布的搭缝用。
注：一般出车，均不附喇叭，如有需要可依以上规格订制

LAP SEAMING

To lap seaming on medium to extra heavy material such as workwears or jeans, etc...

Remark : Folder is not included. Please specify folder no. when ordering.

布料 Material	喇叭代号 Folder No.
中厚料 Medium	B511P
厚料 Heavy	B511Q
极厚料 Extra Heavy	B511R

H3 Device

HF008A-0464-254P/HPR	4	8	1/4-1-1/4" (6.4-25.4-6.4mm)	1.4~3.6	12	TVX5 #18~#21	4500
HF008A-0664-254P/HPR	4 (6)	8	1/8-1/8-1-1/8-1/8" (3.2-3.2-25.4-3.2-3.2mm)	1.4~3.6	12	TVX5 #18~#21	4500



HF008A-0664-254P/HPR/B530



HF008A-0464-254P/HPR

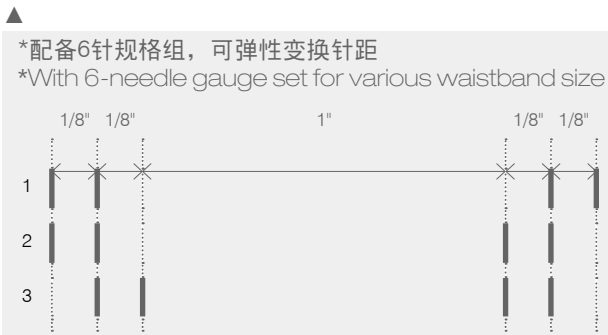
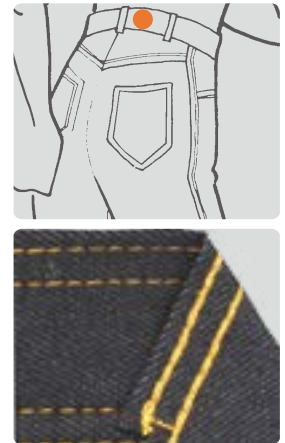

选购配件	OPTIONAL DEVICE
	FH

裤头上带滚边车缝

适用于厚料的工作裤、牛仔裤等裤头的上带滚边一次成型车缝，可依布条的缝合样式选择喇叭。

注：一般出车，均不附喇叭，如有需要可依以上规格订制



WAISTBAND ATTACHING

For tape binding on waistband of workwears pants, jeans...etc. Refer to below table to find optional binders for desirable seams.





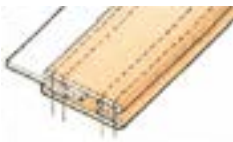
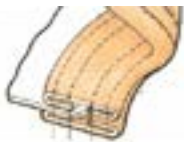

Remark : Binder is not included. Please specify binder no. when ordering.

H3

选配喇叭 OPTIONAL BINDER

成品尺寸 (Finished Size)	上下片直送 For Continuous Strips	上下片弧形 For Arched Type	侧送喇叭 Side Feeding	前送喇叭 Front Feeding
1" (25mm)	-	-	-	B530
1- 1/8" (29mm)	-	-	-	B530P
1- 1/4" (32mm)	B516	B518	B519	B530Q
1- 3/8" (36mm)	B516P	B518P	B519P	B530R
1- 1/2" (38mm)	B516Q	B518Q	B519Q	B530S
1- 5/8" (42mm)	B516R	B518R	B519R	B530T
1- 3/4" (45mm)	B516S	B518S	B519S	B530U
缝合样式 Seam Type				

H4 Device

							
HF008A-0464-254P/PMP	4	8	1/4-1-1/4" (6.4-25.4-6.4mm)	1.4~3.6	12	TVX5 #18~#21	4500
HF008A-0664-254P/PMP	4 (6)	8	1/8-1/8-1-1/8-1/8" (3.2-3.2-25.4-3.2-3.2mm)	1.4~3.6	12	TVX5 #18~#21	4500



HF008A-0664-254P/PMP/
B530

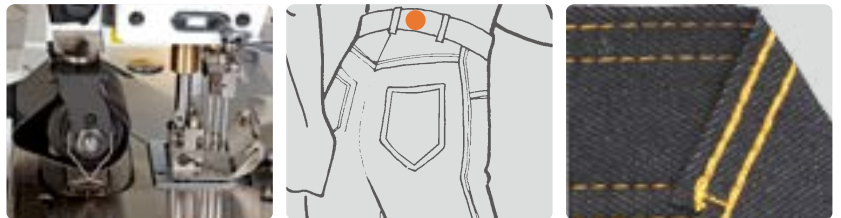

(可调整角度)裤头上带滚边车缝

同HPR裤头上带滚边车缝功能，但角度可进行调整：适用于有曲度的裤腰车缝。

(ANGLE-ADJUSTABLE) WAISTBAND ATTACHING

Same waistband attaching function as HPR, with adjustable angle to process curved workpieces.

H5 Device

HF008A-02056P/FBQ	2	3	7/32"(5.6mm)	1.8~3.6	12	UYX128GAS#10~#11	4200
HF008A-02064P/FBQ	2	3	1/4"(6.4mm)	1.8~3.6	12	UYX128GAS#14~#16	4200



HF008A-02064P/FBQ

裤耳车缝 (附双边切刀)

用本辅助件双边切刀裁布的功能, 可将零碎的废布利用来制作裤耳, 减少布料消耗。

BELT-LOOP SEAMING (WITH RIGHT & LEFT FABRIC TRIMMER)

This machine is equipped with an adjustable fabric trimmer to cut excess fabric edge neatly, and seaming to belt loops for saving cost and increase efficiency.

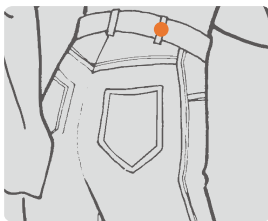

可选择的规格 Available Model	成品尺寸 Finished Size	喇叭代号 Folder No.	适用 Application
HF008A-02056P/FBQ	9 mm	FBQ14A	男女西裤 Trousers
	10 mm	FBQ14B	
HF008A-02064P/FBQ	12 mm	FBQ14C	牛仔布 Jeans

H6 Device

HF008A-0464-254P/PMP/JD	4	8	1/4-1-1/4" (6.4-25.4-6.4mm)	1.4~3.6	12	TVX5 #18~#21	4500
HF008A-0664-254P/PMP/JD	4 (6)	8	1/8-1/8-1-1/8-1/8" (3.2-3.2-25.4-3.2-3.2mm)	1.4~3.6	12	TVX5 #18~#21	4500



HF008A-0664-254P/PMP/JD



牛仔裤腰车缝 (自动跳针)

车缝裤腰时可使用自动跳针机能避开不需缝制的地方。

JEANS WAISTBAND ATTACHING (WITH SKIP-STITCH FUNCTION)

When sewing waistband at the opening area, skip-stitch function can save your time of cutting the seam.

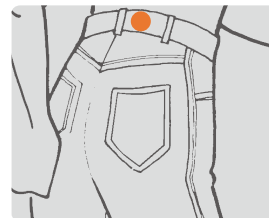

NC008 SERIES FEATURES

NC008

针送牛仔裤腰车

Needle Feed Cylinder Bed Double Chainstitch Machine for Jeans Waistband



后拉轮能在高速车缝时让送布均匀，线迹美观

Rear puller allows stable material feeding and well-balanced seam.



可同步调整线迹长度与送布量的针送+下送送布机构

Needle feed and material feed can be adjusted synchronously.



可对应至16oz的丹宁布等重厚型布料

Work on heavy material like Denim, up to 16 oz.



最适合车缝牛仔裤腰，也可应用于牛仔裤的约克、卷边缝、门襟车缝，上松紧带

Designed for jeans waistband sewing, also can apply on jeans yoke seam, front, and elastic attaching.



配件 / DEVICE



HPR / 裤头上带滚边车缝

适用于厚料工作裤，牛仔裤的上带滚边一次成型车缝左右分开的下轮可用转弯缝制，可依样式选择喇叭。

HPR/Waistband Attaching Device

For tape binding on waistband of workwears pants, jeans...etc.
Refer to below table to find optional binders for desirable seams.



JD / 跳针装置

避开裤腰车缝时不需下针的地方。

Skip Stitch Device

Control freely to avoid stitches sewed on un-wanted working area.

选配喇叭 / OPTIONAL BINDER

成品尺寸 (Finished Size)	上下片直送 For Continuous Strips	上下片弧形 For Arched Type	侧送喇叭 Side Feeding	前送喇叭 Front Feeding
1- 3/8" (36mm)	B516P	B518P	B519P	B530R
1- 1/2" (38mm)	B516Q	B518Q	B519Q	B530S
1- 5/8" (42mm)	B516R	B518R	B519R	B530T
1- 3/4" (45mm)	B516S	B518S	B519S	B530U
缝合样式 Seam Type				

规格 / SPECIFICATION

NCO08				mm		Needle No.	
NC008-02318	2	4	5/4" (31.75mm)	1.4~3.6	9	DXV57 #14~#25	4000
NC008-02381	2	4	3/2" (38.1mm)	1.4~3.6	9	DXV57 #14~#25	4000
NC008-0464-254	4	8	1/4-1-1/4" (6.4-25.4-6.4mm)	1.4~3.6	9	DXV57 #14~#25	4000
NC008-04254	4	8	1" (25.4mm)	1.4~3.6	9	DXV57 #14~#25	4000
NC008-0464-254/HPR	4	8	1/4-1-1/4" (6.4-25.4-6.4mm)	1.4~3.6	9	DXV57 #14~#25	4000
NC008-0464-222/HPR	4	8	1/4-7/8-1/4" (6.4-22.2-6.4mm)	1.4~3.6	9	DXV57 #14~#25	4000
NC008-06064	6	12	1/4" (6.4mm)	1.4~3.6	9	DXV57 #14~#25	4000

PICOTING MACHINE

One / Two Needle Picoting Chainstitch Machine

Z008

-

2

48

Q

机种别 Model

Z008 外曲牙缝纫机
Picoting
Chainstitch
Machine

针数

Needle numbers

1

2

针距

Needle Gauge

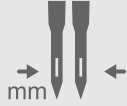

Z008-248Q

代码
Code

型式
Type

车缝导片 / 压具
Guide / Presser Foot

车缝样式
Sewing Pattern

Q 双锯齿型
Double-Picot

ZB11-A

P7873-A

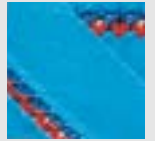

ZB09*

P7872-A*

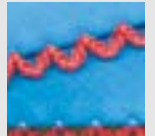

ZB09*

P7872-A*



*备注：置于配件盒当中
*Remark: Parts marked with an asterisk included in the accessory box.



独特的筒型台面设计使车缝更得心应手，更适于筒状物的车缝，整体的外观设计使操作与技术者的维修更容易

Cylinder machine frame design to make sewing operation easier for circular cloth. Easy maintenance and adjustment.



全自动加油系统，润滑各部零件，提升机台寿命

Automatic oiling system to lubricate all spare parts, to extend the machine lifetime.



密闭式针杆及天秤结构，防止漏油
Entirely sealed needle bar and take-up design to prevent oil leakage.



按钮式缝距调整装置，简便省时，节省调整和维护时间。

Stitch length adjustment by knob, saves time for adjustment and maintenance.

可更换不同规格元件，适合多样的锯齿饰边或双锯齿饰边
Different gauge set can be easily changed suitable for various picot sewing.

Z1

Z008-248Q

2

4

3.7~7.4

1

7

UO163 #11

3500

Z型装饰

适用于女用内衣裤、手绢、桌布、礼服、童装、运动装、枕套等各种装饰缝。

ZIGZAG SEWING

Suitable for making decorative zigzag stitches on women's underwears, handkerchiefs, tablecloths, formal dresses, children's wear, sportswears and pillowcases.

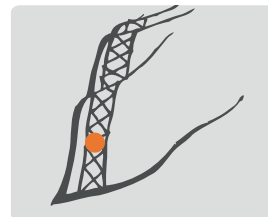

DEVICE



DV¹² 下轴型直驱伺服马达 Lower main shaft type direct drive servo motor

多针链缝机模组化搭配直驱伺服马达，多样化的选择，更有弹性。

¹ = 厂商代码 ² = 版本代码 + 功能代码

Double chainstitch machine equipped with the modularized direct drive servo motors to be more flexible for diversification.

¹ = Manufacturer code ² = Version code + Function code

可自行组装 self-installation: YES

适用机型 applicable model: 全系列多针链缝机 All Double Chainstitch Series



FH 下固定式送带盘 Lower Fixed Tape Holder

置于桌下方放布条或松紧带。

Holds tape or elastic tape under the table

可自行组装 self-installation: YES

适用机型 applicable model: VC008A/VWL, VC008A/VWLB, VC008A/VWLC, HF008A/HPR



JD 跳针装置 Skip Stitch Device

避开裤腰车缝时不需下针的地方。

Control freely to avoid stitches sewed on un-wanted working area.

可自行组装 self-installation: NO

适用机型 applicable model: HF008A, NC008



LSA 上固定式送带盘 Upper Fixed Tape Holder

置于上前方放布条或松紧带。

Holds tape or elastic tape in front.

可自行组装 self-installation: YES

适用机型 applicable model: VC008(A/B)/VPL



RL 筒型衣物撑开滚轮组 Tubular Extending Roller

协助将筒型衣物撑开，便于车缝。

Extends the tubular material to make sewing process easier.

可自行组装 self-installation: YES

适用机型 applicable model: VC008(A/B)/VCE



VAD

气压式抬压脚装置 Pneumatic Presser Foot Lifter

利用气压提升压具可提高效率。

注: 1. 需有空压设备 2. 搭配伺服马达使用

Pneumatic presser foot lifter is used to improve operation efficiency.

Remark: 1. Compressor capability needed. 2. Servo motor needed.

可自行组装 self-installation : YES

适用机型 applicable model : VC008A, VC008B



VAR

密缝装置 Condense Stitching Device

于车缝起始或结束时进行密缝的功能, 确保缝线不易脱落, 提高车缝品质。

Reinforce the stitches at the beginning and end of sewing, to enhance sewing sturdiness and quality.

可自行组装 self-installation : NO

适用机型 applicable model : VC008A, VC008B



VCE

环型裤头松紧带上带装置 Tubular Elastic Inserting and Attaching

用于运动裤或男内裤等圆筒型衣裤上松紧带包缝, 本机型可有两种缝合方式:

1. 环型松紧带布料折边缝。
2. 拷克后上环型松紧带包缝。

Tubular elastic inserting on sportswears or man's underwears, two types of sewing functions are available:

1. To attach tubular seamless elastic waistband.
2. To cover sewing on elastic after overlock seaming.

可自行组装 self-installation : YES

适用机型 applicable model : VC008A, VC008B



VCL(P)

后拉引滚轮 Rear Puller

协助车缝后平顺, 不会挤压。与针位距离 72 mm, 让拉布与出布更稳定。

注: 各机型搭配平轮或齿轮如下表, 若有异于标准品订购时请特别注明。

Smooths the sewing process, and no shirr. The 72 mm distance from the needle helps to stabilize the fabric during sewing process.

Remark: Please check the type of pullers (flat or serrated) used for different machines from the table below. If you would like to order different pullers standard, please remark when ordering other than.

滚轮 / Roller	平轮 / Flat	齿轮 / Gear
上 / Upper	VCL16P	VCL37P(27T)
下 / Lower	VCL28	VCL33P(16T)
VC008(A/B)-04xxxP		S
VC008(A/B)-04xxxP/VCE		S
VC008A-04Axx-xxxP/VSF	S	
VC008A-04xxxP/VWL		S
VC008(A/B)-06xxxP/VPL	S	
VC008A-12xxxP		S
VC008(A/B)-04xxxP/VCE		S
VC008A-12xxxP/VPQ	S	
VC008A-12xxxP/VWLC		S
VC008A-12xxxP/VPQ-K	S	

VCL滚轮明细表 VCL Roller List

Type	平轮 Flat Type		齿轮 Gear Type	压花 Knurling
材质 Material	硬质塑胶 PU (Black)	软质橡胶 Rubber (Black)	塑钢 POM (White)	钢质 Steel
长度 Length	80mm	80mm	80mm	78mm
上滚轮护盖 Upper Cover	VCL39R	VCL39R	VCL39R	VCL39R
上滚轮 Upper	VCL16P	VCL16R	VCL08P(22T) 厚 Heavy	VCL08N (22T)
			VCL37P(27T) 中厚 Medium	
下滚轮 Lower	VCL28	VCL28R	VCL33(14T) 厚 Heavy	VCN33N(22T)
			VCL33P(16T) 中厚 Medium	
			VCL61(28T) 薄 Light	
			VCL64(32T) 轻薄 Fine	

滚轮选用原则 Puller Set Application

平轮 Flat type	塑胶 PU	适用一般薄布料，如梭织棉布 For common materials, eg: woven cotton fabric.
	橡胶 Rubber	适用贴带车缝，或光滑薄布料使用，如梭织丝光布 For tap attaching or slippery materials, eg: woven silk fabric.
齿轮 Gear type	粗齿塑钢 Big-teeth POM	适用松紧带车缝，大折景 For elastic band sewing, big gathering
	粗齿塑钢 Fine-teeth POM	适用松紧带车缝，小折景 For elastic band sewing, small gathering
钢质压花轮 Knurling Steel roller		适用牛仔类与厚布料 For jeans and heavy material

可自行组装 self-installation : NO

适用机型 applicable model : VC008A, VC008B



VPQ

弹性线抽折缝装置 Elastic Thread Shirring

适用于女用裙皱折，连身衣裙等腰边松紧带皱折均能顺畅缝纫，勾针底线宜用弹性线。
Suitable for sewing ornamental shirring on women's blouses. Suggested to use elastic thread for lower looper.

可自行组装 self-installation : YES

适用机型 applicable model : VC008A-12048P, VC008A-12064P



VPQ-K

弹性线抽折缝装置 Elastic Thread Shirring

适用于女用裙皱折，连身衣裙等腰边松紧带皱折均能顺畅缝纫。

1. 勾针底线宜用弹性线。
2. 增加VWL组可稳定松紧带的松紧度让车缝更平顺美观，不跳针。
3. 将弹性线安装于桌板下，让弹性线车缝更顺畅。
4. 本配件为多功能，可调为VWL，VPQ单一使用。

Suitable for sewing ornamental shirring on women's blouses.

1. Suggested to use elastic thread for lower looper.
2. The added VWL set will further stabilize the tension of elastic thread and make sewing process more smoothly, also can avoid stitch skipping.
3. Holds the elastic thread under the table to make sewing process more smoothly.
4. Multifunction device can be adjusted to VWL or VPQ.

可自行组装 self-installation : YES

适用机型 applicable model : VC008A-12048P, VC008A-12064P



VPL

贴带装置 Tape Attaching

主要用于衬衫门襟，腰带，运动衣等装饰条带。

注：1.喇叭成品规格如图表。

2.布条的尺寸可依3/16"或1/4"倍数变换。

Decorative tape for shirt-fronting, sportswears, waist band, etc...

Remark: 1. Folder and finished goods specifications as listed in the table below

2. Tape size can be adjusted in multiples of 3/16" or 1/4".

机型 Model	完成尺寸 Finished Size(mm)	X	Y	Z	针距 Needle Gauge	压具 Presser Foot
VC008(A/B)- 06048P	8	B417P	B417AP	B417P	3/16"	P9412DA
	9	B417Q	B417AQ	B417Q		P9412D
VC008(A/B)- 06064P	10	B417R	B417AR	B417R	1/4"	P9512DA
	12	B417S	B417AS	B417S		P9512D
	16	B417U	B417AU	B417U	1/2"	P9512B

可自行组装 self-installation : YES

适用机型 applicable model : VC008(A/B)-06048P, VC008(A/B)-06064P



VPS

弹性线抽折缝装置 Elastic Thread Shirring

适用于女用裙皱折，连身衣裙等腰部松紧带皱折，如：女衬衫、游泳衣、妇女用衣物、枕头套、儿童衫。针线用弹性线，勾针为勾线功能不穿线，为101车缝式样。

Suitable for sewing ornamental shirring on women's blouses, swimsuits, pillowcases, children's shirts. Needle uses elastic thread and looper without any thread. It's 101 sewing type.

可自行组装 self-installation : YES

适用机型 applicable model : VC008A-12048P, VC008A-12064P



VWL VWLB VWLC

前松紧带送带滚轮装置 Front Elastic Feeding

松紧带送带滚轮装置能随机台本身的运转，将松紧带送出，且可调整松紧带送出量的多少，操作简便：车缝慢跑裤，运动裤，休闲裤等裤头，由于前后导轮装置，上松紧带时能保持一定张力，维持车缝品质。

注：VWL 附 B413 喇叭

VWLB 附 B411喇叭及撑开滚轮组

VWLC 附 VCE 导片

Length of elastic type can be easily adjusted by elastic feeding device, suitable for sports pants and casual pants. Roller maintains the tension of elastic thread and quality during sewing process.

REMARK: VWL with folder B413

VWLB with folder B411 and extending roller

VWLC with VCE fabric guide

可自行组装 self-installation : YES

适用机型 applicable model : VC008A-04064P, VC008A-04085P, VC008A-04095P,
VC008A-04106P, VC008A-04127P, VC008A-12048P,
VC008A-12064P



VSC

松紧带抽皱缝装置 Elastic Thread Shirring Sewing

弹性线直送不打线圈，由针线与勾针线上下包覆，车缝成品效果较VPQ薄，且皱折可拉伸至完全平坦。

Elastic thread is straight, not looped, which is fixed by needle thread and looper thread. The finish is thinner than VPQ and the shirring becomes flat as it is pulled extensively.



可自行组装 self-installation : NO

适用机型 applicable model : VC008A-12048P, VC008A-12064P



VSF

门襟车缝装置 Shirt-Fronting

对于各种衬衫门襟用四针或二针，因有专用滚边器配合使用，只要一道工序即可完成，连续缝纫非常顺畅。喇叭尺寸如图表：

Using 4 or 2 needle and special folder for shirt-fronting, only one sewing process is required. Size of folder as listed in the table below.

规格Spec 代号Code	完成尺寸 Finished Size	人布宽度 Tape Size	针距 Needle Gauge	机型 Model
B529	1-3/8"	2-3/8"	1/4 - 3/4 - 1/4"	VC008A-04A64-191P
B529Q	1-5/8"	2-5/8"	1/4 - 1 - 1/4"	VC008A-04A64-254P

可自行组装 self-installation : YES

适用机型 applicable model : VC008A-04A64-191P, VC008A-04A64-254P



VUT

自动切线装置 Pneumatic Automatic Thread Trimmer

气动式自动切线可提高车缝效率节省成本。

Pneumatic automatic thread trimmer increases operation efficiency and saves the cost.

可自行组装 self-installation : NO

适用机型 applicable model : VC008(A/B)-04085P, VC008(A/B)-12048P, VC008(A/B)-12050P, VC008(A/B)-12064P



VC008 弹性线机型对照/ VC008 Comparison on Elastic Thread Models

型号 Model	布样 Sample Fabric	面线(针线) Surface Thread (NeedleThread)	底线(勾针线) Rear Thread (Looper Thread)	花样线 Decorative Thread	备注 Remark
VPQ		一般 Standard	弹性线 Elastic	-	
VPQK		一般 Standard	弹性线 Elastic	-	车缝与VPQ完全相同 差别在多加VWL下送轮, 使底线控线稳定 Same stitch as VPQ. The difference is on the front roller, VWL, which stabilizes rear thread controls.
VPS		弹性线 Elastic	无 None	-	勾针不穿线 Looper without thread.
VSC		一般 Standard	一般 Standard	-	弹性线拉直, 由底线与面线包 Elastic thread is stretched and covered by rear thread and surface thread.

TABLE

桌板代号 Item No.	尺寸 / Size (mm)			说明 Description	适用机型 Applicable Model	备注 Remark
	长 Length	宽 Width	厚 Thickness			
VC008-T1	1200	540	45	半沉式 Semi-submerged	VC008(A/B)-04 VC008(A/B)-04P/VCE, VUT	
VC008-T2	1200	540	45	上乘式 Non-submerged		开口型 Open type
VC008-T3	1200	540	45	半沉式 Semi-submerged	VCO08B-11, VCO08B(A/B)-12,VCO08A-13, VCO08(A/B)-06/VPL, VC008A-12/VPQ, VCO08(A/B)-12/VUT	
VC008-T4	1200	540	45	上乘式 Non-submerged		开口型 Open type
VC008-T5	1200	540	45	半沉式 Semi-submerged	VC008A-04/VWL, VWLB, VWLC	
VC008-T6	1200	540	45	半沉式 Semi-submerged	VC008A-12/VPQK, VWL	
VC008-T9	1200	540	45	半沉式 Semi-submerged	VC008A-12/VSC	
VC008-T10	1200	540	45	全沉式 Full-submerged	VC008(A/B)-04, VC008A-12	需搭配 SM899-A SM899-A set required
VC008-T25	1200	600	45	上乘式 Non-submerged	VC008(A/B) for SLA	
HF008-T1	1200	540	45	半沉式 Semi-submerged	HF008(A)	
HF008-T3	1200	540	45	全沉式 Full-submerged	HF008(A)	
HF008-T4	1200	540	45	半沉式 Semi-submerged	HF008(A)/FBQ	
Z008-T1	1200	540	45	半沉式 Semi-submerged	Z008	
Z008-T2	1200	540	45	上乘式 Non-submerged	Z008	开口型 Open type
NC008-T1	1200	600	45	上乘式 Non-submerged	NC008	开口型 Open type

ONE NEEDLE LOCKSTITCH MACHINE

DL7200C

-

B

M

1

A

-

16

机种别 Model

DL720 直驱单定针平缝车
Direct Drive
Needle Positioning
Lockstitch Machine

DL7200C 单步进电脑平缝车
Computerized
Lockstitch Machine
with Single
Stepping Motor

DL7200D 双步进电脑平缝车
Computerized
Lockstitch Machine
with Double
Stepping Motor

DL7500 双步进电脑触控平缝车
Computerized
Lockstitch Machine
with Double
Stepping Motor and
Touch Panel

旋梭 Hook

- 1 高速缝梭头
High Speed Hook
- 2 大旋梭
Large Hook

送布牙 Feed Dog

- 四排牙
4 Rows of Teeth



A 三排牙
3 Rows of Teeth



功能选配 Function Option

功能码 Function	快速倒缝 Reverse Feeding	拨线杆 Wiper	电子夹线 Thread Gripper	自动抬压脚 Auto Lifter	防鸟巢 Bird Nest Prevention	自动切线 Auto Trimming
10	-	-	-	-	-	√
11	√	√	-	-	-	√
12	√	-	-	√	-	√
13	√	√	-	√	-	√
15	√	-	√	-	-	√
16	√	-	√	√	-	√
17	√	-	√	√	√	√

特性 Features

R 右切刀
Vertical Edge
Trimmer

B 旋转式切线系统
Rotary Thread
Trimming

N 针送布
Needle Feed

RN 右切刀针送布
Edge Cutter &
Needle Feed

车缝布料 Sewing Material

L 薄布料
Light

M 中厚布料
Medium

H 厚布料
Heavy

HM 中厚至厚布料
Medium & Heavy

X 牛仔料
Jeans

DL720 SERIES FEATURES



DL720 直驱单定针平缝车 Direct drive Needle Positioning Lockstitch Machine

- 机电一体化整合，内置电控箱及控制台，安装简易，使用方便。
- 直驱伺服马达，反应快速，动作准确，比离合器马达省电60%。
- 使用方便：配备 LED 照明，内置式绕线器与补针功能。
- Mechatronic integration with built-in control box and control panel. It is easy to install and operate.
- Direct drive servo motor is speedy, accurate, and energy-saving than clutch motor by 60%.
- User friendly: Equipped with LED light, built-in bobbin winder, and stitch compensation function.

DL720	mm	Needle No. DB × 1	布料厚度 Fabric Weight			mm		mm	S.P.M. (Max)
			L	M	H	手动 Hand	膝动 Knee		
M1	15.8	#11~#14				5.5	13	0~4	4000
H1	18.0	#18~#21						0~5	3500
M1A	15.8	#11~#14						0~6.5	4000

DL720 -RM1 直驱单定针带刀平缝车 Direct drive Needle Positioning Lockstitch Machine & Edge Cutter



30mm 落料空间：
废料从落料口自然滑落，每时每刻保持清爽干净。

30mm space:
30mm space for giving up the waste, it brings out with a clean working space.



黑金刚镀层：
刀架导杆均采用 DLC 涂层处理，更耐用更耐磨。

Special black coating:
Cutter's stick is made with DLC coating which helps to increase durability.



简易定针型可搭配喇叭组，进行布条滚边车缝（喇叭为三折卷，入布宽度 28mm，出布宽度 8~10mm）

Needle position function models can equip with binders, to perform tape binding. (Binders are with 3 folders; entering width is 28mm, exiting width is 8~10mm for material.)

DL720	mm	mm	Needle No. DB × 1	布料厚度 Fabric Weight			mm		mm	S.P.M. (Max)	mm	KG
				L	M	H	手动 Hand	膝动 Knee				
RM1-32	3.2	15.8	#11~#14				4	10~13 (可调 Adjustable)	0~4	3700	L630 W245 H540	34.5 / 37.5
RM1-48	4.8											
RM1-64	6.4											

※ 选配桌板：DL7000T-T1 ※ Optional Table : DL7000T-T1

DL7200C SERIES FEATURES

DL7200C 单步进电脑平缝车 Computerized Lockstitch Machine with Single Stepping Motor



专利斜板自动式抬压脚、搭载智能主板由核心准确控制针距，精度可达 0.1mm 的误差。
智能控制作动行程、误差，达到准确无声倒缝。

Stepping motor controls stitch length and reverse stitch. It enables precision control over the stitch length to get an accuracy of 0.1mm and gives reverse stitches precisely on the top of the previous ones.



特点

FEATURES

- 【专利】斜板自动式抬压脚：**
降低电磁铁负载、耐用度提升。
Patented inclined plane design of auto-
presser foot lifter will lead to a significant increase of the
electromagnetic service life and enhance its durability.
- 大风量手轮设计，高效率散热**
Big hand wheel with cooling fan design improves the
heat dissipation efficiency.
- 具备智能操控屏幕与 USB 接口**
Intelligent control panel with USB port
- 出厂预设 9 种花样缝，也可弹性设定花样，满足
多种缝纫需求**
Up to 9 standard sewing patterns for different needs
and the sewing patterns can also be customized upon
request.



规格

SPECIFICATIONS

DL7200C	mm — — —	mm ↑	mm ↑			Needle No. DB × 1	S.P.M. (Max)	自动切线 Auto trimming	倒缝 Reverse Feeding	电子夹线 Thread Gripper	自动抬压脚 Auto Lifter		
BM1(A)-15Q	0~5 / A : 0~7	15.5	手动 Hand 5.5	膝动 Knee 13	自动 Auto 10	#11~#14	4500	V	V	V	—		
BM1(A)-16Q	0~5 / A : 0~7							V	V	V	V		
BH1(A)-15Q	0~5 / A : 0~7	18				#20~#23	4000	V	V	V	—		
BH1(A)-16Q	0~5 / A : 0~7							V	V	V	V		
BX2(A)-15Q	0~5 / A : 0~7							#20~#23	4000	V	V	V	—
BX2(A)-16Q	0~5 / A : 0~7									V	V	V	V

* A : 表示针板、送具为三排齿 A : Needle plate, feed dog have three gears.
无 : 表示针板、送具为四排齿 None : Needle plate, feed dog have four gears.

DL7200C-RM1

单步进带刀电脑平缝车

Computerized Lockstitch Machine with Single Stepping Motor & Edge Cutter

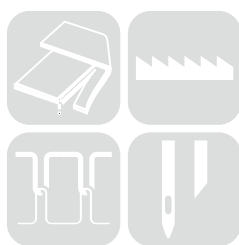

采用内置式直驱伺服马达，实现了机器的快速启动和制动的准确度；大幅度降低了噪音和振动，并降低了能耗，与普通的驱动装置相比，电量耗减 35% 以上，适用于缝制各类衬衫、西服或类似服装，特别是其衣领、前襟等部位，高速缝制时倒顺送料针距能保持完全一致，侧切刀装置使缝纫和修刀工序一次完成，工作效率提高。

With built-in direct drive servo motor to achieve the accuracy of the machine's rapidstart-up and braking; a significant reduction in noise and vibration, and reduce energy consumption, compared with conventional drive unit, battery depletion of 35% or more, suitable for sewing various shirts, suits or similar garments, especially it's collar, breast and other parts, inverted send high-speed sewing material pitch to be completely consistent, side cutter device sewing and knife trimming procedures in one time efficiency.

特点

FEATURES

30mm 落料空间：
废料从落料口自然滑落，每时每刻保持清爽干净。

30mm space:
30mm space for giving up the waste, it brings out with a clean working space.

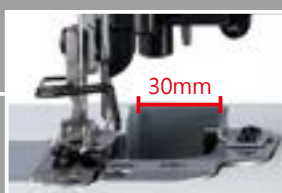

USB 介面：
超能 USB 界面。

USB interface:
Versatile USB interface equipped.



1 倒缝步进电机驱动：

步进电机控制倒缝和针距，准确度达到 0.1mm，针距准确，重针度高，针距可锁定，不会因为传统标盘针距长久使用后导致针距忽大忽小。

Reverse sewing driven by stepping motor:

Stepping motor controls reverse sewing and needle movement. Actual precision can be as 0.1 mm. Needle gauge, which can be locked in, is precise with sewing repetition. It would not have the issue of unstable needle gauge using with traditional needle gauge device.

2 新静界，新智缝：

采用步进电机驱动倒缝，加固，声音轻，给你安静舒适的工作环境。而且可实现锁针，花样加固缝等传统结构无法实现的功能。

Quietness and Intelligence:

Manipulating the reverse sewing with stepping motor, it brings a calm environment. Other than traditional structure, it offers function of lockable needle and pattern sewing.

3 黑金刚镀层：

刀架导杆均采用 DLC 涂层处理，更耐用更耐磨。

Special black coating:

Cutter's stick is made with DLC coating which helps to increase durability.



规格

SPECIFICATIONS

DL7200C												
	mm	mm	mm	mm	mm	mm	mm	mm	mm	mm	mm	mm
RM1-32-12	3.2	0~4	15.5	手动	膝动	自动	#11~#14	3700	V	V	-	V
RM1-48-12	4.8			Hand	Knee	Auto						
RM1-64-12	6.4			5.5	13	10						

※ 选配桌板：DL7000T-T1 ※ Optional Table : DL7000T-T1

DL7200D FEATURES

DL7200D 双步进电脑平缝车 **Computerized Lockstitch Machine with Double Stepping Motor**



- 双步进马达驱动，动作连贯
 - 起缝微鸟巢，结束短线头，实现优美的车缝品质
 - 完整而优良的各项细节
-
- Double stepper motors drive for the perfect coherent movements
 - Starting with micro-bird nest, ending with short thread head, for the beautiful sewing quality
 - Complete and excellent details

特点

FEATURES

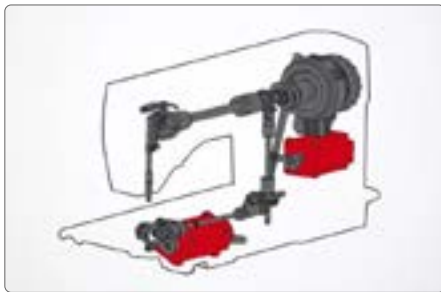

双步进马达驱动，动作连贯

底部的步进马达控制双动刀切线与抬压脚，右侧的步进马达控制针距与倒缝，以电控技术串联每一个缝纫机功能，动作连贯。

Double stepper motors drive for the perfect coherent movements

The bottom stepper motor controls the double knives thread trimmer and presser foot lifter, and the right side stepper motor controls the stitch distance and reverse stitch. The computer control technology integrates every function of the sewing machine, and realize the perfect coherent movements.

起缝微鸟巢，结束短线头，实现优美的车缝品质

动作连贯，起缝时机针上只需极短线头，大幅降低底面的鸟巢现象，稳定的双动刀切线，可达 3 mm 以下的短线头，实现优美的车缝品质

Starting with micro-bird nest, ending with short thread head, for the beautiful sewing quality

Due to the perfect coherent movements, it requires a very short thread head at the needle at the sewing starting, which significantly reduces the bird nest on the bottom side. The double knives thread trimmer is very stable, and it makes the ending with Max. 3 mm thread head, which realize the beautiful sewing quality.

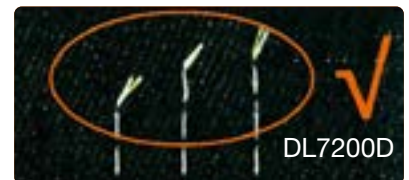

完整而优良的各项细节 Complete and excellent details

照明与快速键三合一模组
Lighting and hot key
3-in-1 module

缝制多达 9 种不同线迹
Swing up to 9 different
stitch patterns

密封油盘
Closed oil pan

电子膝控抬压脚
Electronic knee touch
presser foot lifter

USB 充电埠
USB charging port

规格

SPECIFICATIONS

DL7200D	mm 	mm 	 mm			Needle No. DB X 1	 S.P.M. (Max)
BM1	0~5	15.5	手动 Hand 5.5	膝动 Knee 13	自动 Auto 9	#11~#14	4500
BM1A	0~7	15.5				#11~#14	4500
BH1	0~5	18				#20~#23	4000
BH1A	0~7	18				#20~#23	4000

功能 Function	代码 Function Code	自动切线 Auto trimming	倒缝 Reverse Feeding	电子夹线 Thread Gripper	自动抬压脚 Auto Lifter	防鸟巢 Bird nest prevention
	16	V	V	V	V	-
	17	V	V	V	V	V

DL7200D-NM1

DL7200D-NH1

双步进针送电脑平缝车

Computerized Needle Feed Lockstitch Machine with Double Stepping Motor



采用内置式直驱伺服马达，实现了机器的快速启动和制动的准确度；大幅度降低了噪音和振动，并降低了能耗，与普通的驱动装置相比，电量耗减 35% 以上，适用于缝制各类衬衫、西服或类似服装，特别是其衣领、前襟等部位，高速缝制时倒顺送料针距能保持完全一致。

With built-in direct drive servo motor to achieve the accuracy of the machine's rapidstart-up and braking; a significant reduction in noise and vibration, and reduce energy consumption, compared with conventional drive unit, battery depletion of 35% or more, suitable for sewing various shirts, suits or similar garments, especially it's collar, breastand other parts, inverted send high-speed sewing material pitch to be completelyconsistent.

特点

FEATURES

完整而优良的各项细节 Complete and excellent details

本机采用连杆式针送料结构，针送料方式使送料特性更加稳定，缝层的间不易产生滑移。



The machine adopt connecting rod control feeding system, the needle feeding method make the feeding system more stable, during multi-sewing the fabric not easy to moving.

四个按键：
配有四个功能键，方便进行倒缝加固、补针（补1针，补1/2针，1/4针）操作。



Four buttons:
Equipped with four functional buttons, so that it is convenient for backstitch and stitch compensation(1 stitch, 1/2 stitch, 1/4 stitch)

黑金钢针杆：
采用 DLC 涂层针杆，减少了头部供油，显著减少针杆漏油。



Needle bar made with black gold metal:
DLC coating helps to decrease the oil supply and to prevent the needle bar from oil leakage.

1 步进马达电子针距控制技术：
实现倒缝与正缝针脚高度重合。
Stepping motor electronic stitch length control:
The stitch height of reverse stitching and normal stitching are aligned.

2 步进马达双向驱动技术 (专利技术)：
一个马达完成切线和抬压脚动作。
Two-way stepping motor technology(patented):
One motor completes thread trimming and presser foot lifting.

3 短线头：
采用电机驱动的双动刀剪线机构，可在机针正下方完成剪线，缝纫后的线头最短可达 3mm，可有效减少人工剪线的工作量。
Short thread head:
The shortest thread head is down to 3mm, which can effectively reduce workload of manual trimming.

4 花样缝：
DL7200D-NM1/NH1 可以透过设定产生 9 种不同线迹。
Pattern stitch:
DL7200D-NM1/NH1 stepping motor offers 9 different patterns.

5 低噪音：
优化的机壳设计和主轴马达结构，机器运转时噪音低：采用步进马达控制加固缝，加固时无声响：采用步进马达控制抬压脚，压脚提升和下降时声音轻柔：采用步进马达驱动切线，切线声音大幅度降低。
Low noise:
With optimized internal design and with stepping motor without bearing, DL7200D-NM1/NH1 is quiet when reverse feeding, presser foot lifting, and trimming.

6 密封油盘设计：
避免油污造成的缝料污染，同时可减小整机运作时的噪音。
Oil tank design:
Sealed oil tank to avoid fabric from grease and to reduce noise when machine operates.

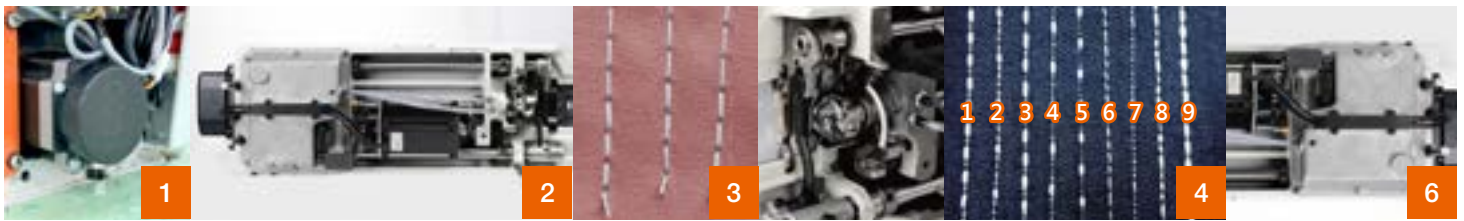

规格

SPECIFICATIONS

DL7200D	Needle No. DB×1	布料厚度 Fabric Weight			mm			mm	S.P.M. (Max)	mm	KG
		L	M	H	手动 Hand	膝动 Knee	自动 Auto				
NM1-16	#9 ~ #14				5.5	13	9~10	0~4.5	3500	L620 W280 H550	46 / 39.8
NH1-16	#18 ~ #21							0~5.5	3500		

功能 Function	代码 Function Code	自动切线 Auto Trimming	倒缝 Reverse Feeding	电子夹线 Thread Gripper	自动抬压脚 Auto Lifter	防鸟巢 Bird Nest Prevention
	16	V	V	V	V	-

DL7500 SERIES FEATURES



DL7500 双步进电脑触控平缝车 Computerized Lockstitch Machine with Double Stepping Motor and Touch Panel

本机采用一体式智能操作系统，配备 4.3 寸触摸显示屏，简化操作逻辑，参数调整更加便捷。无轴承主轴伺服马达、花样米粒缝、包油盘、电子膝控、短线头等功能，且送布、剪线、抬压脚为步进电机驱动，稳定低噪音，功能齐全，质量稳定。



This machine adopts an integrated intelligent operating system, equipped with a 4.3-inch touch screen, which simplifies the operation logic and makes parameter adjustment more convenient. Special features includes bearing-less spindle servo motor, pattern stitch, sealed oil tank, electronic knee pad, short thread trimmer.

Feeding, thread trimming and presser foot lifting are driven by stepping motors, which is stable and quiet. Completed functions and stable quality.

特点

FEATURES

1 步进马达电子针距控制技术： 实现倒缝与正缝针脚高度重合。

Stepping motor electronic stitch length control:
The stitch height of reverse stitching and normal stitching are aligned.

2 步进马达双向驱动技术（专利技术）： 一个马达完成切线和抬压脚动作。

Two-way stepping motor technology(patented):
One motor completes thread trimming and presser foot lifting.

3 短线头： 采用电机驱动的双动刀剪线机构，可在机针正下方完成剪线，缝纫后的线头最短可达 3mm，可有效减少人工剪线的工作量。

Short thread head:
The shortest thread head is down to 3mm, which can effectively reduce workload of manual trimming.

4 花样缝： DL7500 可以透过设定产生 9 种不同线迹。

Pattern stitch:
DL7500 stepping motor offers 9 different patterns.

5 低噪音： 优化的机壳设计和主轴马达结构，机器运转时噪音低；采用步进马达控制加固缝，加固时无声响；采用步进马达控制抬压脚，压脚提升和下降时声音轻柔；采用步进马达驱动切线，切线声音大幅度降低。

Low noise:
With optimized internal design and with stepping motor without bearing, DL7500 is quiet when reverse feeding, presser foot lifting, and trimming.

6 密封油盘设计： 避免油污造成的缝料污染，同时可减小整机运作时的噪音。

Oil tank design:
Sealed oil tank to avoid fabric from grease and to reduce noise when machine operates.

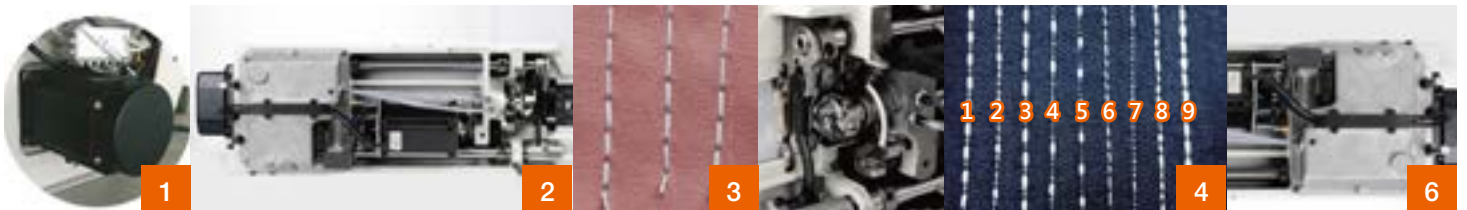

完整而优良的各项细节 Complete and excellent details

全新触控显示屏：
4.3 英寸彩色触摸屏，内容直观，操作方便



Advanced touch screen:
4.3-inch colored touch screen, intuitive and convenient.

四个按键：
配有四个功能键，方便进行倒缝加固、补针（补 1 针，补 1 / 2 针，1 / 4 针）操作。



Four buttons:
Equipped with four functional buttons, so that it is convenient for backstitch and stitch compensation (1 stitch, 1/2 stitch, 1/4 stitch)



黑金钢针杆：
采用 DLC 涂层针杆，减少了头部供油，显著减少针杆漏油。

Needle bar made with black gold metal:
DLC coating helps to decrease the oil supply and to prevent the needle bar from oil leakage.

规格

SPECIFICATIONS

DL7500	Needle No.	布料厚度 Fabric Weight			mm			mm	S.P.M. (Max)	mm	KG
		L	M	H	手动 Hand	膝动 Knee	自动 Auto				
BM1-16	DB×1 #9 ~ #16				5.5	11	11	0~5	4500	L620 W280 H550	37.4 / 43.5
BM1-17											
BH1-16	DP×5 #18 ~ #21							0~7			
BH1-17											

功能 Function	代码 Function Code	自动切线 Auto Trimming	倒缝 Reverse Feeding	电子夹线 Thread Gripper	自动抬压脚 Auto Lifter	防鸟巢 Bird Nest Prevention
	16	V	V	V	V	-
	17	V	V	V	V	V

DL7500 -RNM1

双步进带刀针送电脑触控平缝车 Computerized Needle Feed Lockstitch Machine with Double Stepping Motor and Touch Panel and Edge Cutter



本机通过针送布防止缝纫料的层移动和过骨的针迹堆积。调节操作简便、设计精巧、省时省力、使缝制与切除缝料边一次完成。采用步进马达控制针脚长度、倒回缝、剪线无声、可缝制9种不同线迹。适用于缝制各种服装、男女衬衫、童装、床单、窗帘等。



This machine uses needle feed system to prevent the layer movement of the sewing material and the accumulation of stitches passing through cross seam. The adjustment operation is simple, the design is exquisite, time-saving and labor-saving, and the sewing and cutting of the sewing material can be completed at one time. Stepping Motor-controlled stitch length, reverse sewing, silent thread trimming, and 9 different stitches can be sewn. Suitable for sewing all kinds of clothing, men's and women's shirts, children's garment, bed sheets, curtains, etc.

特点

FEATURES

- 1 无轴承主轴伺服马达:**
直接使用主轴作为电机轴, 无需用联轴器连接, 主轴刚性好、力矩轻, 电机运转声音轻。

Bearingless Spindle Servo Motor:

The main shaft is directly used as the motor shaft, and there is no need to connect with a coupling, the main shaft has good rigidity, light torque, and the motor has a light running sound.

- 2 步进马达双向驱动技术 (专利技术):**
一个马达完成切线和抬压脚动作。

Two-way stepping motor technology(patented):

One motor completes thread trimming and presser foot lifting.

- 3 可离合式切刀开关:**
实现切布与非切布缝制功能切换。

Clutchable cutter switch:

Achieve the switching between cutting and non-cutting sewing functions.

- 4 花样缝:**
DL7500 可以透过设定产生 9 种不同线迹。

Pattern stitch:

DL7500 stepping motor offers 9 different patterns.

- 5 高品质的加固缝线迹:**
步进电机控制针距与倒缝: 针距准确、倒缝无噪声; 前、后加固缝功能有效缩短留在缝料上的线头长度, 防止线头松散。

High-quality bartack stitches:

Stepper motor controls stitch length and reverse stitching: precise stitch length and noiseless reverse stitching; the front and back stitching functions effectively shorten the length of the thread left on the sewing material and prevent the thread from loosening.

- 6 电子膝控:**
比传统机械膝控更加轻柔, 减小操作负荷。

Electronic knee control:

Softer than traditional mechanical knee control, reducing operating load.

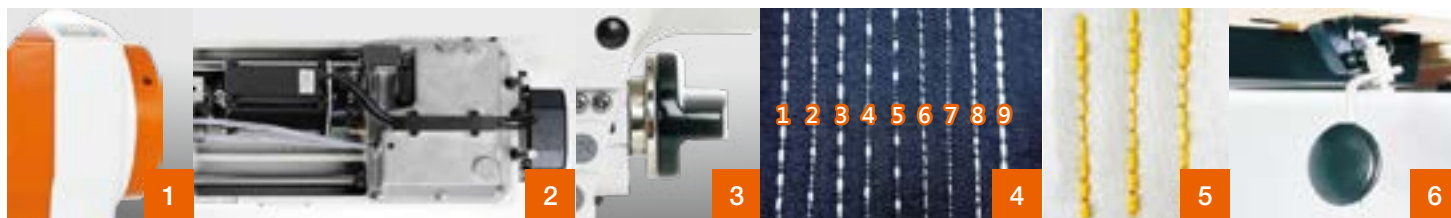

完整而优良的各项细节 Complete and excellent details

全新触控显示屏：
4.3英寸彩色触摸屏，
内容直观，
操作方便



Advanced touch screen:
4.3-inch colored touch screen,
intuitive and convenient.

多功能补针开关：
可实现改变针距补针功能。



Multi-function stitch compensation switch:
It can realize the function of changing
stitch length to make up the needle.



针送料结构：
本机采用连杆式针送料结构，针送料方式
使送料特性更加稳定，缝层的间不易产生
滑移。

This machine adopts the connecting rod type
needle feeding structure, the needle feeding
method makes the feeding characteristics
more stable, and it is not easy to slip between
the seam layers.

规格

SPECIFICATIONS

DL7500	mm	! Needle No. DB × 1	布料厚度 Fabric Weight			mm			mm	S.P.M. (Max)	mm	KG
			L	M	H	手动 Hand	膝动 Knee	自动 Auto				
RNM1-32-16	3.2	#9 ~ #16							0~5	4000	L620 W280 H550	40 / 46
RNM1-48-16	4.8					5.5	11	11				
RNM1-64-16	6.4											

功能 Function	代码 Function Code	自动切线 Auto Trimming	倒缝 Reverse Feeding	电子夹线 Thread Gripper	自动抬压脚 Auto Lifter	防鸟巢 Bird Nest Prevention
	16	V	V	V	V	-

TWO NEEDLE LOCKSTITCH MACHINE

DT828L

-

42

-

064

M

/

C

①机种别 Model

DT828 直驱双针平缝车
Direct Drive Double
Needle Lockstitch
Machine

DT828L 双步进双针电脑平缝车
Computerized Double
Needle Lockstitch
Machine with Double
Stepping Motor

③针距 Needle Gauge



No.	mm	inch
032	3.2	1/8"
048	4.8	3/16"
064	6.4	1/4"

④车缝布料 Sewing Material

M 中厚布料
Medium

H 厚布料
Heavy

⑤自动切线 Auto Thread Trimmer

	机型 Machine Series	拨线 Thread Wiper	自动抬压脚 Auto Lifer
C-13	DT828L	V	V

②功能 Function

规格 Sub-Class	针送 Needle Feed	标准旋梭 Standard Hook	大旋梭 Big Hook	倒缝 Reverse Feeding	角缝 Split Needle Bar
42	V	V	-	V	-
45	V	V	-	V	V
72	V	-	V	V	-
75	V	-	V	V	V

DT828

FEATURES



DT828 直驱双针平缝车

Direct Drive Double Needle Lockstitch Machine

- 针送式送料，缝目准确，并可自由调整大小，缝目稳定美观。
- 采用旋转水平式旋梭，并附自动给油装置。
- 附有检视底线用的窗口，方便查看梭仔线的余量。
- The design of needle feed mechanism moves with simple operation , excellent stitching and precise stitch-length.
- Adopting fully rotating horizontal axis hook , slide type thread take-up as well as automatically lubricating system.
- Convenient window for monitoring bobbin thread volume.

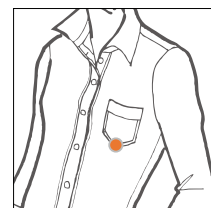

一般平缝
General plain seaming

特点

FEATURES



- 1 机电一体化的理想整合：
内置电控箱及控制台，安装简易，使用方便。
Perfect mechnronic combination:
Built-in control box & panel, easy to install and operate.
- 2 直驱伺服马达：
反应快速，动作准确，比离合器马达省电 60%。
Direct drive servo motor:
Quick reaction, precise movement, 60% energy saving compared to clutch motor.

3 倒缝拨杆装置:
可以轻松实现倒缝缝纫。
Reverse lever:
Easy to achieve reverse.

4 缝距控制钮:
转动调整达到理想缝距。
Stitch length control button:
Rotate to get ideal stitch length.

5 简易式操作面板装置:
操作内容直观，简单方便。
Simple control panel:
User friendly, easy to operate.

6 边角缝装置:
从缝纫角度和针数决定距宽，使得边缝质量良好。
Split stitching device:
Decide the ideal width by sewing angle and stitches numbers, it will make good quality of split stitching.



规格

SPECIFICATIONS

DT828	mm	Needle No. DP×5	布料厚度 Fabric Weight			mm	手动 Hand	mm	S.P.M. (Max)	mm	KG
			L	M	H						
42	4.8 6.4	#14 - #22				7	M : 0~4 H : 0~5	3600	L730 W315 H670	49 / 52	
45											
72							M : 0~7 H : 0~7	3000			
75											

功能 Function	规格 Sub-Class	针送 Needle Feed	标准旋梭 Standard Hook	大旋梭 Big Hook	角缝 Split Needle Bar
	42	V	V	-	-
	45	V	V	-	V
	72	V	-	V	-
	75	V	-	V	V

DT828L

FEATURES

DT828L

双步进双针电脑平缝车 Computerized Double Needle Lockstitch Machine with Double Stepping Motor



- 上轴采用通轴设计，整体力矩轻，机器运转平稳，送料流畅。
- 本机采用 750W 大功率伺服电机直接驱动，噪音低、振动小，安装方便，启动停车反应迅速，机针贯穿力强。
- 双步进驱动技术，实现缝、加固、剪线和抬压脚无声。
- 密封式油盒设计，清洁无污染。
- 电子膝控装置，抬压脚轻盈省力，降低劳动强度。
- LED 照明灯亮度三档可调。
- 多键位操作面板，操作内容直观，简单方便。
- 一体式背挂式电控，安装方便。
- The upper shaft adopts the through-all design; the overall torque is light; the machine runs smoothly; and the feeding is smooth.
- 750W high-power servo motor: larger needle penetration force, lower noisy, lower vibration, easier to install and shorter responding time.
- Stepping motor with bidirectional driven technique: powerful, stable as well as quiet when end back-tacking, reinforced stitching, trimming, and presser foot lifting.
- The sealed lubricate design: avoid fabrics from grease effectively.
- Electronic knee control pad makes the foot lifter light and easy to operate.
- 3-level LED light.
- Multi-functional panel: intuitive and user-friendly.
- Integrated back-mounted control box; easy to install.

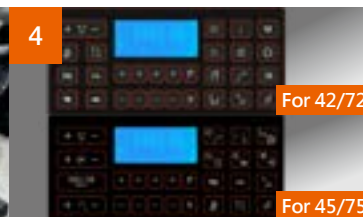

- 1 步进马达双向驱动技术 (专利技术):**
一个马达完成切线和抬压脚动作。
可靠的切线机构:
切线机构采用步进马达驱动，结构简单、切线稳定、方便维护。

Stepping motor bidirectional driven technology (patent):
One step motor control trimming and pressing foot lifter work.

The unique thread trimmer device:
Adopt step motor to drive, stable, light noise and convenience on maintenance.

- 2 直刀剪线结构:**
直刀剪线机构，剪线稳定。
Straight knife system:
Straight knife thread trimming mechanism, stable thread trimming.

- 3 密封油盘设计:**
缝料清洁无污染。
The sealed lubricate design:
Effectively avoid the material dirty from oil.

- 4 多功能键操作面板:**
操作盒按键内容直接，操作简便迅速。
Multi-function key operation panel:
The operation box has direct key content, and the operation is simple and rapid.

完整而优良的各项细节 Complete and excellent details



角缝车缝
Split needle bar sewing

一般车缝
General sewing

多功能按键设置：

可以轻松实现转角、倒缝、密缝、补针等缝纫。

The multifunctional buttons: easy to achieve angle change, reverse stitch, seam stitch and stitch compensation.



高品质的加固缝线迹：
采用步进马达控制的送料机构，准确控制送料行程，任何针距下都可以实现线迹重合的加固缝。

High-quality reinforcement stitches: Step motor can accurately control the feeding, making reinforcement available for any stitch length.

电子膝控：
不改变工人的操作习惯实现轻松抬压脚。



Electronic knee pad: Without worker changing operating habits, presser foot can be easily lifted.

规格

SPECIFICATIONS

DT828L	mm	Needle No. DP×5	布料厚度 Fabric Weight			mm	mm	S.P.M. (Max)	mm	KG	
			L	M	H						手动 Hand
42	3.2 4.8 6.4	#11 ~ #16				7	8-12 (可调 Adjustable)	3000	L680 W290 H640	55 / 62	
45											M : 0~4 H : 0~5
72		#14 ~ #22									M : 0~7 H : 0~7
75											

功能 Function	规格 Sub-Class	针送 Needle Feed	标准旋梭 Standard Hook	大旋梭 Big Hook	倒缝 Reverse Feeding	角缝 Split Needle Bar
		42	V	V	-	V
	45	V	V	-	V	V
	72	V	-	V	V	-
	75	V	-	V	V	V

DT828 Series	③ mm	mm			Needle No. DP×5	mm	S.P.M. (Max)		倒缝 Reverse Feeding	拨线杆 Wiper	自动抬压脚 Lifter	角缝 Split Needle Bar
		手动 Hand	膝动 Knee	自动 Auto								
DT828-42-③M	048 064	7	10	-	#14	0~4	3600	Direct drive AC Servo motor	√	-	-	-
DT828-42-③H					#22	0~5	3000		√	-	-	-
DT828-45-③M					#14	0~4	3000		√	-	-	√
DT828-45-③H					#22	0~5	3000		√	-	-	√
DT828-72-③M			10		#14	0~7	3000		√	-	-	-
DT828-72-③H			13		#22	0~7	3000		√	-	-	-
DT828-75-③M			10		#14	0~7	3000		√	-	-	√
DT828-75-③H			13		#22	0~7	3000		√	-	-	√
DT828L-42-③M/C-13	032 048 064	-	8-12	#11~#16	0~4	3000	√	√	√	-		
DT828L-42-③H/C-13				#11~#16	0~5	3000	√	√	√	-		
DT828L-45-③M/C-13				#11~#16	0~4	3000	√	√	√	√		
DT828L-45-③H/C-13				#11~#16	0~5	3000	√	√	√	√		
DT828L-72-③H/C-13				#14~#22	0~7	3000	√	√	√	-		
DT828L-75-③H/C-13				#14~#22	0~7	3000	√	√	√	√		

TABLE

桌板代号 Item No.	尺寸 / Size(Mm)			说明 Description	适用机型 Applicable Model
	长 Length	宽 Width	厚 Thickness		
DL7000T-T1	1200	540	40	全沉式 Fully-submerged	DL720, DL7200C, DL7200D, DL7500
DT828L-T	1200	535	40	半沉式 Semi-submerged	DT828L
DT828-T	1200	545	40	半沉式 Semi-submerged	DT828

PS SERIES

Direct Drive Programmable Electronic Pattern Sewing Machine 直驱可程式电子花样机



新一代伺服步进驱动技术

马达运行更准确，长时间工作状态下，马达温升低，回应速度更快

New Generation Servo-stepping driving technology

The motor runs more accurately, and the response speed is faster. The temperature rises lower under long working conditions.

采用高阶直驱马达

最高速度达到2800 S.P.M.，生产效率进一步提高，启动与停车反应迅速，与传统型相比缩短19%，提高生产效率，耗电低，经济实用，与传统型相比减少50%

High quality direct drive servo motor

As the maximum speed reaches 2800 S.P.M. so the production efficiency is more improved. The start / stop response is rapid, which is 19% shorter than the conventional type. Low power consumption makes it economy and practical, which is 50% lower than the conventional type.

以0.05mm的最小解析度实现美观的缝纫线迹

每脉冲0.05的高解析度，PS系列可缝制出滑顺的曲线，并且可做简单的绣花图案，就连一般刺绣机很难胜任的厚面料刺绣也可完成

The min. resolution 0.05mm realizes perfect sewing quality.

With a high resolution of 0.05 per pulse, PS series can make a smooth curve, and a simple embroidery pattern. Even a thick fabric embroidery is available, which is difficult for a typical embroidery machine.

标配断线感测器

发生断线时，可侦测并立即停机，报警提示

Thread breaking sensor is standard equipped

When it happened thread breaking, the machine senses the problem and then stop with alarm.

可选配数位线张力控制器

传统方式以手感调整面线张力，配备数码夹线器可以数位化设定，实现稳定的缝制品质

**Digital tension controller is optional**

Adjusting the upper thread tension with human feeling is the old way. With the digital tension controller can be set easily to realize the stable sewing quality.

裁片定位简单准确

马达驱动式抬压脚 (S type)的行程，可选择设定为1步或2步下降

Sewing material setting is easy and accurate

Motor-drive type presser foot (S type) can be set the stroke as 1-step or 2-step.

均匀稳定的收线

在低张力下，可以稳定收线，由于中压脚的高度可以改变，即使面料厚度有段差的变化，也可保持适当压力，确保均匀稳定的收线效果

Stable and uniform seam tightness

Under low tension condition, the seam tightness can be stabilized. Because the height of the intermediate presser can be changed, even if the thickness of the fabric changes as a step, the proper pressure can be maintained to ensure a uniform and stable seam tightness.



搭载WIFI功能，与生产管理系统快速对接，即时传输设备的缝纫资料
支持多种媒体，搭载1个SD卡插槽、2个USB埠

Built-in WIFI function for easy connection to production management system and sewing data real-time transmission.
Multi-data input with 1 SD card slot and 2 USB ports.

使用“NS600”程式设计软体

可快速简便的编辑花样，更可相容“VDT、SEW”等格式花样，修改花样更简便，可根据图示和命令，轻松创建缝纫资料

NS600 pattern editing software

Easy pattern editing by computer. VDT, SEW, and the other format compatible.



- 程式编程画面，使用说明图示，可轻松创建缝纫程式
Pattern editing panel with instruction for easy creating your sewing patterns.



- 简洁的缝纫资料修改区，可快速修改花样图形准确实现需要的缝纫资料
Compact sewing data tuning area for quick modification.

- 直观显示缝纫资料，无需调取其他界面查看
Intuitive display of sewing data without changing the page.

- 功能区选择介面，图形化显示，便于使用者选择
Function selection area with graphical display for user friendly.

- 资料读入读出简单快捷，一键完成
Input and output easily.

配件

DEVICE



MY 帽沿
Cap brim

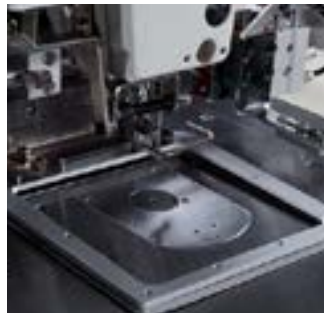

SS 侧移压脚
Side shift clamp



HM 快速换模
Template fast changing



FZ 反转压脚
Inverted Clamp



规格

SPECIFICATION

PS-1010A-01S
 PS-1010A-01A
 PS-1010A-01A/SS
 (100 X 100 mm)
 PS-1310A-01S
 PS-1310A-01A
 (130 X 100 mm)
 PS-1510A-01S
 PS-1510A-01A
 (150 X 100mm)



PS-2210A-01A
 (220 X 100mm)
 PS-2516A-01A
 (250 X 160mm)



PS-3020A-01A
 PS-3020A-01A/HM
 PS-3020A-01A/MY
 (300 X 200 mm)
 PS-3525A-01A
 (350 X 250 mm)
 PS-4030A-01A*
 (400 X 300 mm)
 *压具为 □ 型
 *presser foot is □ type



PS-2210AL-01A
 (220 X 100 mm)



PS-6040A-01A
 (600 X 400 mm)

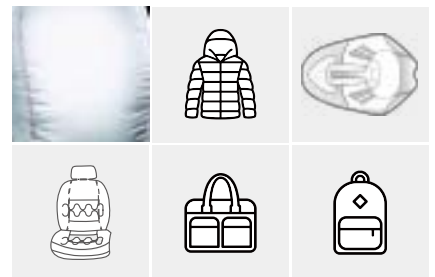

规格 Specification	1010A-01S	1310A-01S	1510A-01S	2210A-01A	2516A-01A	3020A-01A	3525A-01A	4030A-01A	6040A-01A
	1010A-01A	1310A-01A	1510A-01A			3020A-01A/HM			
	1010A-01A/SS			2210AL-01A		3020A-01A/MY			
线迹 Stitch Type	单针锁缝 Single Needle Lockstitch								
最高缝制速度 Max. Sewing Speed	2800 S.P.M.								
缝制区(X x Y) Sewing area (X x Y)	100 X 100	130 X 100	150 X 100	220 X 100	250 X 160	300 X 200	350 X 250	400 X 300	600 X 400
送布方式 Feeding	间歇性送布 (步进马达驱动) Intermittent Feeding (Stepping motor drive mode)								
针距 Stitch length	0.05~12.7 mm								
最大针数 Max. stitch	20,000 针/ 图形 20,000 stitch / pattern								
压脚驱动方式 Work Clamp Drive	S: 步进马达驱动 A: 气动式 S: Stepping motor drives A: Pneumatic drive			气动式 Pneumatic drive					
压脚上升量 Work Clamp Lift Amount	S: Max. 25 mm A: Max. 30 mm			Max. 30 mm					
两步压脚 2-step work clamp	S: 左右一体式 A: 左右分离式 S: Integrated-type A: Separate-type			左右分离式 Separate-type					左右一体式 Integrated-type
间歇压脚上升量 Stepping Presser foot Height	22 mm								
间歇压脚行程 Stepping Presser foot Stroke	0 或 2~10mm (出厂预设3mm) 0 or 2~10mm (Default setting 3mm)								
旋梭 Hook	半回转2倍梭 Double Capacity Shuttle Hook								
扫线 Thread Wiper	标配 Standard								
切线 Thread Trimmer	标配 Standard								
数位线张力控制器 Digital Tension Controller	选配 Optional								
断线感测器 Thread Breakage Detector	标配 Standard								
外部资料储存 External Data storage	经由 USB 埠 Inputted by USB Port								
马达 Motor	直驱式 AC伺服马达 750W Direct drive AC Servo Motor 750W								
电源 Power	单相 220V, 三相 380V Single Phase 220V, 3-Phase 380V								
重量 Weight	机头: 88 kg, 电控箱: 14~16kg Machine Head: 88 kg, Control Box: 14~16kg				机头: 166 kg, 电控箱: 14~16kg Machine Head: 166 kg, Control Box: 14~16kg	机头: 174 kg, 电控箱: 14~16kg Machine Head: 174 kg, Control Box: 14~16kg		机头: 184 kg, 电控箱: 14~16kg Machine Head: 184 kg, Control Box: 14~16kg	机头: 224 kg, 电控箱: 14~16kg Machine Head: 224 kg, Control Box: 14~16kg
气压/ 用风量 Air Pressure/ Consumption	0.5MPa 1.7L /min								

BT SERIES

Electronic High-speed Lockstitch Bartacking / Button Sewing/ Small Area Pattern Sewing Machine

BT

430

Q

-

01

机电一体
Mechatronic

机种别
Model

430	套结 Bartacking
438	钉扣 Button Sewing
439	立扣 Shank Button
530	两用型 套结/钉扣 2-in-1 Bartacking/ Button
630	小型花样机(80X60) Small Pattern Sewing (80X60)

车缝应用
Sewing Application

01	标准 Standard
02	厚料 Heavy Material
03	帽眼 Radial Tacking
05	裤耳 Belt Loop
06	松紧带拼接 Elastic Band Joining
07	针织 Knits Material

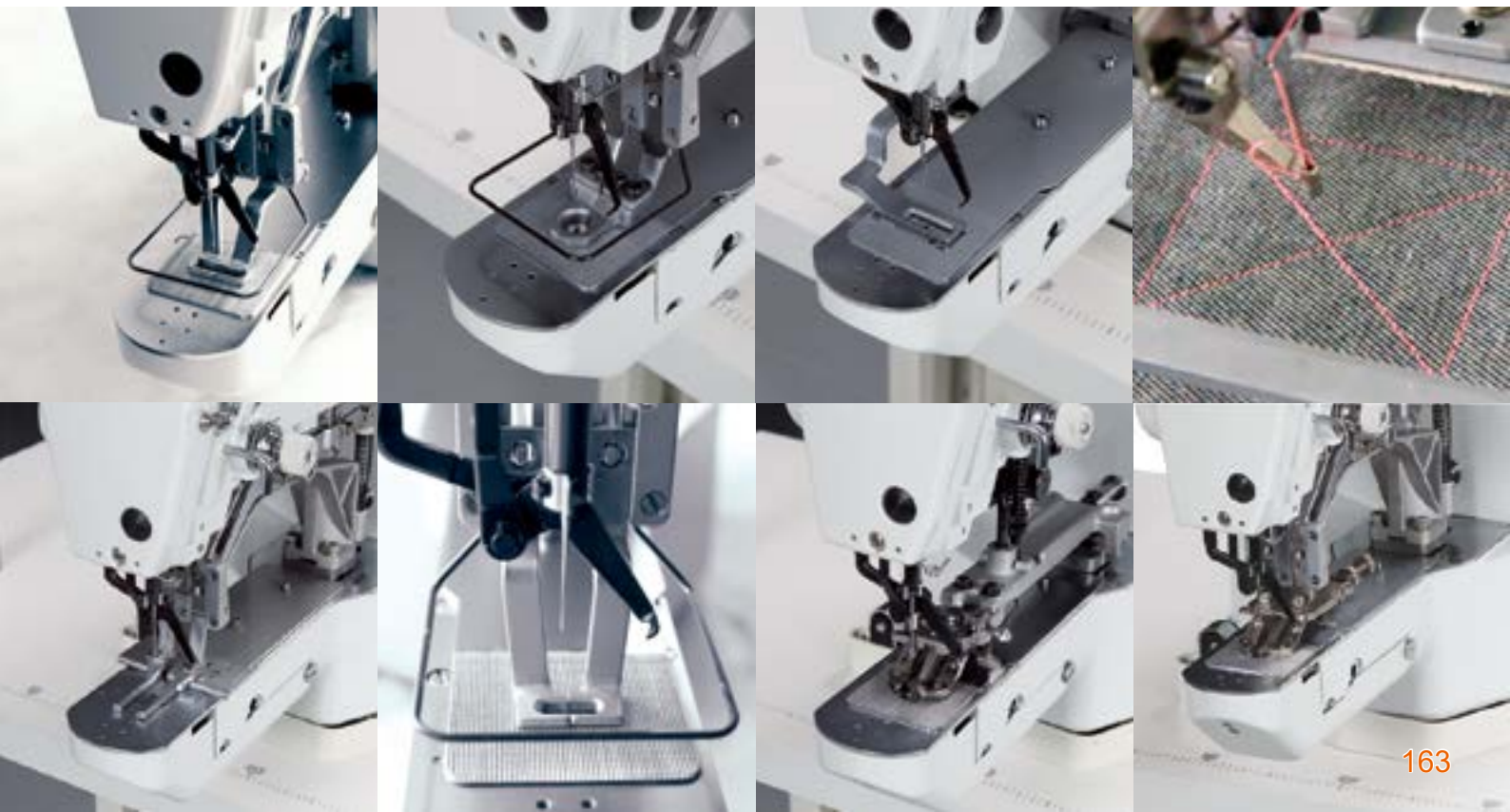

无油机构设计

采用DLC 针棒，挑线机构轴承设计，以固态油脂润滑，有效防止面料油污问题。

Oil-free Mechanism Design

With DLC needle bar, thread take-up lever's bearing design, and grease lubrication, it avoids the problem of oil stain.

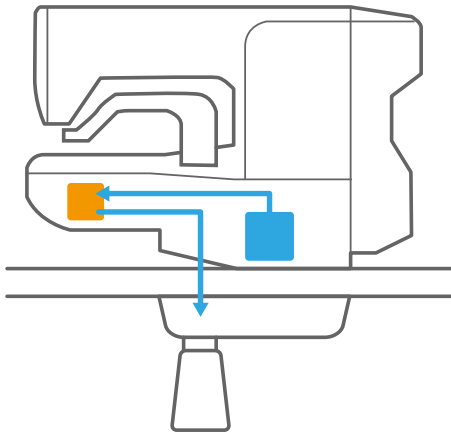

双踏板模式

支援双踏板操作模式，缝制特殊产品时，定位更容易。

Dural Pedal Mode

Support double pedal mode for special sewing operation. It makes the material positioning easier.



操作面板内建USB埠

以USB 记忆体进行图形资料储存，方便快捷。

Control Panel with Built-in USB port

It is easy and convenient for Pattern input by USB memory



适用范围大

中厚料规格，可以改进挑线行程，提高线迹稳定度，扩大厚料缝制性能。

Wider Range of Sewing Application

For heavy material, with thread take-up lever's stroke changing, it makes the stitches stable and upgrades the sewing performance.



短线头设计

改进切线结构，在针孔最近点线，使余线长度变短，减少修线工作。

Short Thread End Design

Improving the thread trimming mechanism to cut the thread at the nearest spot from the needle. It shortens the thread end and reduces the finishing job.

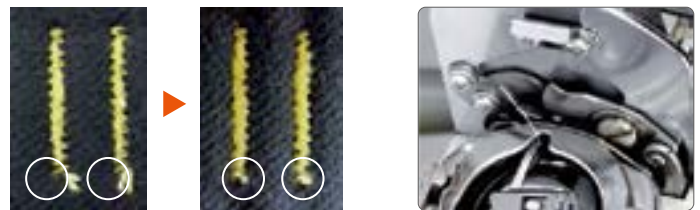

BT630Q

均匀的大压脚压力

可对大压脚角度进行调节，使得四周压力均衡，确保缝制物稳定。

Dural Pedal Mode

Support double pedal mode for special sewing operation. It makes the material positioning easier.



均匀稳定的收线

由于间歇压脚提升量可以改变，当裁片厚度变化时，不会产生压力过大或不足的问题，确保在低张力下仍可稳定收线。

Consistent and Stable Thread Tightness

As the stepping presser foot's height can be changed, no problem of excessive or insufficient pressure with the sewing material thickness changing, it makes the stable thread tightening.



BT430Q-01 / 02

01 标准
Standard

02 厚料
Heavy material



BT430Q-03

帽眼
Radial tacking



BT430Q-05

裤耳
Belt loop



BT430Q-06

松紧带拼接
Elastic Band Joining



BT430Q-07

针织
Knits material



BT438Q

钉扣
Button sewing



BT530Q

两用型 套结/钉扣
2-in-1 Bartacking/ Button sewing

出厂时为套结机，钉扣套件附在配件盒中，用户可以操作面板切换车缝模式

Bartacking is the standard setting, while the button sewing kit is included. Customer can change the sewing mode by control panel.



BT630Q

小型花样机(80X60)
Small Area Pattern Sewing (80X60)



代号 Code	BT430Q						BT439Q	BT438Q	BT530Q	BT630Q
	01	02	03	05	06	07				
用途 Application	标准 Standard	厚料 Heavy material	帽眼 Radial tacking	裤耳 Belt loop	松紧带拼接 Elastic Band Joining	针织 Knits material	立扣 Mushroom button sewing	钉扣 Button sewing	两用型 套结 / 钉扣 2-in-1 Bartacking/ Button sewing	小型花样机 Small Pattern Sewing
最高缝制速度 Max. Sewing Speed	3200 S.P.M.						2700 S.P.M.		3000 S.P.M.	
缝制区域 (X x Y) Sewing area (X x Y)	40X30	40X30	15X15	40X30	9X40	40X30	6.4X6.4		40X30	80X60
钮扣尺寸 Button Size							12mm	8~30mm		
送布方式 Feeding							间歇性送布 (步进马达驱动) Intermittent Feeding (Stepping motor drive mode)			
针距 Stitch length	0.05~12.7 mm									
最大针数 Max. stitch	5000 针/ 图形 5000 stitch / pattern									
抬压脚 Presser foot lifter	步进马达驱动 Stepping motor drives									
压脚 / 钮夹上升量 Height of Presser foot/ Button clamp Lifting	Max. 17mm						Max. 13mm		Max. 17mm Max. 13mm	Max. 17mm
旋梭 Hook	半旋转标准旋梭 Standard Shuttle hook									
外部资料储存 External Data storage	经由 USB 埠 Inputted by USB Port									
循环缝 Cycle program	最多30组, 每组上限50个步骤 Max. 30 sets, each set includes Max. 50 steps.									
记忆容量 Memory Capacity	内建 89种图形, 最多可追加 512种图形 / 500,000针 Built-in 89 patterns, Max. 512 patterns / Max. 500,000 stitches can be added.									
马达 Motor	直驱式 AC伺服马达 550W Direct drive AC Servo Motor 550W									
电源 Power	单相 220V Single Phase 220V									
重量 Weight	机头: 约 57 kg, 操作面板: 约 0.4 kg, 控制箱: 约 9 kg Machine Head: about 57 kg, Operation Panel: about 0.4 kg, Contro Box: about 9 kg									

Accurate sewing based on sewing data

先进电子技术准确控制，生产效率与缝纫品质得到高水准提升

BH-9820 SERIES

电子圆头锁眼机

Direct Drive Programmable
Electronic Eyelet Button Holer



BH-9820-00

BH-9820-01

BH-9820-02

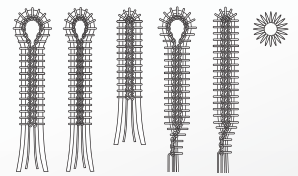

特点

FEATURES

1 改良气缸

优化改进的可携式气管界面，随插即用，用户外接气源更简便

Improved cylinder

Improved pipe port to make connection much easier.



- 2 特殊工艺加工处理的齿轮和凸轮，大幅度降低了机器噪音及振动，经过科学的实验测试，噪音比历史资料降低了8-10个分贝，操作工的舒适度大大提升

Special process processing of gears and cams,a significant reduction in the machine noise and vibration,after a scientific experimental test,the noise than the historical data reduced by 8-10db,the operator's comfort greatly improved.



3 准确调整简单易行

切刀间隔和切刀位置补正等准确调整可在液晶显示幕的操作盘上进行。专案以图示显示，操作人员无需阅读也可直观地进行操作

Easy adjustment

The position and adjustment of cutting knife can be adjusted by operate panel.All these adjustments will be showing in the operate panel in image.

4 提高了图案的准确性

采用了伺服控制的送布装置提高了刚性，因此可缝制出高精度图案，即便高速缝纫或缝制重物时，也不会产生电子缝纫机常有的失调偏位。伺服控制还免去了初始位置的检测

Making the accurate pattern

The machine controlled by servo system,it makes the patterns accurate even in high speed stitching.servo control system avoid the initial position checking.

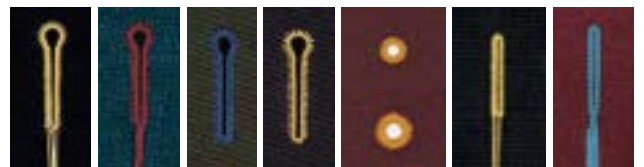

5 减少跳针

优化弯针形状，挑线量和其他零件。无论使用何种类型的线，由于线张力的改变而引起的跳针和针脚不够紧密的情况都减少了，使缝纫能力得到扩张

Reduce skip stitch

Improved the looper and thread take-up, machine can stitch different fabric with different thread.

缝纫能力扩展图

Sewing capacity expansion picture

(面线张力 / Tension force of stream thread)

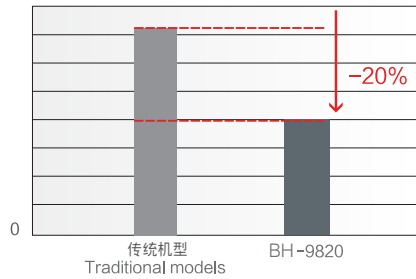

3.0mm宽度的字缝，缝纫后裁剪
2块聚酯纤维(其中一块的一侧有夹层)
纺线：# 40
底线张力：30g
缝纫速度：2,500 S.P.M.

3.0mm-wide zigzag sewing, after-sewing cutting.
2 pieces of polyester serge (one side of one piece has a layer).
Span thread : # 40
Tension force of end thread : 30g
Sewing speed : 2,500 S.P.M.

6 短切面线及底线剪线器的特殊规格 (-02)

-02 规格中，单机支援较大范围的应用，从休闲裤的平头扣眼加固缝到牛仔裤的流线扣眼加固缝。该规格的缝制长度范围为：18-26 mm

special specification of thread trimmer for -02 model

The machine model -02 can stitch big size pattern for both casual pants and jeans.the length of eyelet button hole can be 18-26mm.

8 操作简单的操作盘

BH-9820 带有液晶显示屏(LCD)，并以图示和文字显示，设置或查看图案以及更改缝制模式时，便于理解并易于操作

Easy operation

BH-9820 has liquid crystal display (LCD), supported by icon and character display. When setting or checking pictures and changing sewing mode, it is easy to understand and operate.



7 以图示和文字显示便于理解

The display of icons and characters makes it easy to understand



多语言显示 Multi-language display

功能拓展

FUNCTION EXTENSION



应用实例

APPLICATION EXAMPLE

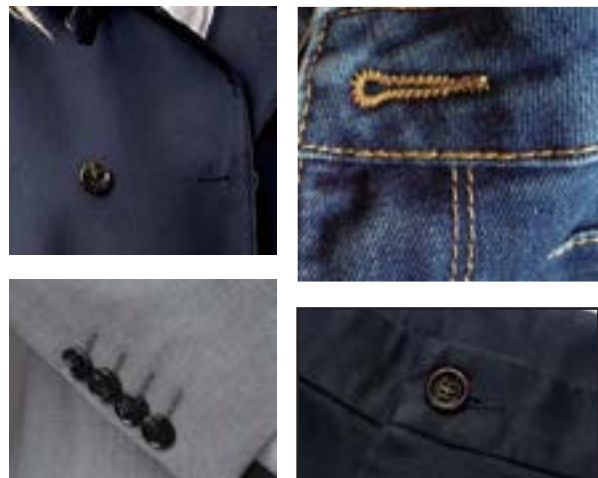

规格 Specification	BH-9820-00	BH-9820-01	BH-9820-02
面线剪线装置 Needle thread trimmer	长线剪切 Long thread trim	长线剪切 Long thread trim	短线剪切 Short thread trim
底线剪线装置 Bobbin thread trimmer	无 None	长线剪切 Long thread trim	短线剪切 Short thread trim
主要用途 Main applications	女装 Suit-dress	男装、休闲装 Men's clothing,casual clothing	牛仔裤、裤装 Jeans trousers,trousers
其他用途 Other applications	男装、休闲装、牛仔裤、裤装 Men's clothing,casual clothing,jeans trousers,trousers	女装、牛仔裤、裤装 Suit-dress,jeans trousers,trousers	—
功能 Function	剪线装置仅剪切面线。 可缝纫最长为50mm的扣眼。 Only trim the needle thread.The max. Length of button hole is 50mm;	剪线装置将较长地剪切所有线头。 在缝纫持续过程中可在更长距离内安全把握线尾。 Trimming both needle thread and bobbin thread	剪线装置将较短地剪切线头， 这样可省去动手。 Trimming both needle thread and bobbin thread.No need second trim
缝制形状 Sewing shape			
缝纫长度 Sewing length	圆头锁眼 8-50mm 直形钮孔 8-50mm Round-head eyehole 8-50mm Straight button hole 8-50mm	圆头锁眼 8-42mm 直形钮孔 5-42mm Round-head eyehole 8-42mm Straight button hole 5-42mm	22-30mm* 14-22mm* 18-26mm* 26-34mm* 34-42mm*
压脚长度(标准) Press foot length (standard)	30mm		30/26mm
刀垫长度(标准) Length of hammer (standard)	22mm		24/20mm
刀垫长度(附件) Length of hammer (accessory)	30mm		28/24mm
缝纫速度 Sewing speed	1000~2500 S.P.M.		
针码 Needle code	0.5~2.0mm		
的字缝宽度 Zigzag sewing width	1.5~5.0mm (在机械条件下最宽为4.0mm的字缝宽度补偿最多为5.0) 1.5~5.0mm (In mechanical conditions, it is 4.0mm wide at most and the zigzag sewing width is 5.0 At most.)		
的字缝宽度(出厂设置) Zigzag sewing width (factory setting)	2.5mm		3mm
流线加固缝长度 Length of stream thread	0~20mm		
压脚高度 Height of work clamp	标准高度为12mm(最高可达16mm) Standard height is 12mm (may reach 16mm at highest)		16mm
启动方式 Start-off mode	手动开关 / 双踏板开关 Hand start switch / Double pedal switch		
送布装置 Fabric feeding device	三个步进马达的间歇送布 (x,y, θ) Intermittent cloth-sending of 3 stepping motors (x,y, θ)		
机针*4 Machine needle 4	DOx558 Nm80 - Nm120		
安全设备 Safe setting	若有问题发生, 有紧急停止功能和由安全电路驱动的内置自动停止设备 If there are any problems, the inner setting with urgent stop function and driven by safe circuit will automatically stop the machine		
上轴马达 Upper shaft motor	AC伺服马达550W AC-servo motor 550W		
空气压力 Air pressure	主调整器 : 0.5Mpa; 锤压调整器 : 0.4Mpa Main regulator : 0.5Mpa; Hammer-pressure regulator : 0.4Mpa		
空气消耗量 Air consumption volume	43.2升/分钟(8周/分钟) 43.2 liter/minute (8 cycles/minute)		
电源 Power supply	单相 100V / 200V, 三相 200V /220V/ 380V/ 400V, 400VA Single phase 100V / 200V, Three phases 200V /220V/ 380V/ 400V, 400VA		
重量 Weight	机头: ≈ 120kg / 操作盘: ≈ 0.6kg / 控制箱:14.2-16.2kg Machine head: ≈ 120kg / Operation board : ≈ 0.6kg / Control box :14.2-16.2kg		

LBHS-1790D Series

Computer-controlled, High-speed, Lockstitch Buttonholing Machine 高速电子平头锁眼机



应用范围

APPLICATIONS

采用新型旋梭，实现美观线迹效果。高效节能、舒适缝纫！

Machine with the new type rotary hook gives smooth operation and maximize sewing work efficiency!

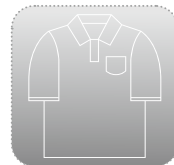

特点

FEATURES



三角缝
Purl stitch



平缝
Whip stitch

采用新型旋梭，防止断线，收线不良等缝纫跟问题。低张力线迹美观，三角缝和平缝都能很好呈现。

The new type rotary hook helps to prevent thread breaks, uneven winding and other related issues. With low tension, machine makes a quality finish for purl stitch and whip stitch.



代表性的缝纫图案
Standard and round end patterns



细小图案也能呈现美观的线迹。Beautiful stitches even in small patterns.

针摆最小分辨率每个脉冲提高0.05mm，防止切刀后切开部位起毛。各种缝纫图案都能准确缝制。Achieve minimum resolution of needle zigzag with 0.05 increment to prevent thread with fraying ends. It is capable to work on different type of sewing patterns.



规格

SPECIFICATION

型号 Model	用途 Application	 mm	 DP x 5	 mm	 S.P.M. (Max)	缝制区域 (X×Y) Sewing area (X×Y)	 KG
LBHS-1790DS	标准品 Standard	6.4~31.8mm	#11 ~ 14	34.6	4200	X:5mm, Y:41mm (选配件最大可缝制 Max.Y:120mm) (Y:120mm is max for optional device)	68kg / 72kg
LBHS-1790DK	针织布 For Knit						
标准缝纫图案 Number Of Standard Patterns				30			
存储图案数 Max. Number Of Stored Memory Patterns				50			
最大针数 / 1 个程序 Max. Number Of Stitches Per Program				999			
数据存储方式 Data Storage Method				经由 USB 埠 USB port			
电源 Power Supply				单相 Single-phase 110V/220V 三相 Three-phase 220V/380V			

LKS-1900D Series

Computer-controlled, High-speed, Lockstitch, Bartacking Machine 高速电子平头套结机

- 精工品质，智慧高效，性能出色。
- 电控与机头一体式设计，安装更便捷。
- 全新操作面板，调用图案便捷，图案一致性高。
- 新型的自动抬压脚和剪线机构，速度更快更稳定。
- 干式无油机头，无需担心污染缝料、更环保。
- 全密封内润滑机构，整机噪音更低，使用寿命持久。
- Focus on quality, efficiency and performance.
- Control box and machine head connect together; easy for installation.
- Brand new control panel, easy to use.
- New design for auto presser foot lifter and for automatic thread trimmer; with faster and more stable performance.
- Machine head with oil-free structure; no oil stains; environment-friendly.
- Sealed structure of lubrication; low noise; longer service life.



特点 FEATURES

1 闭环控制系统:

步进马达闭环智慧运动控制系统，能够即时监控机械结构的运动趋势，对运动偏差进行即时补偿和修正：减少高速运行时的失步，消除了机械配合误差，提高动作精准度，达到提升效率的目的。

Closed control system :

stepping motor closed control system can do immediate monitor of the mechanic movement, both make up and correct the deviations, cut the reaction time, rise the efficiency and accuracy, ensure the productivity.

2 高效地生产性能:

实现了高速的缝制速度 3,300 S.P.M.，通过高速的性能，能快速启动和终止缝制，通过高速的切线速度以及自动抬压脚操作，大幅度缩短了套结循环时间。

Higher productivity :

The machine realizes high speed 3,300 S.P.M., in addition to the high speed sewing performance, cycle time can be substantially decreased.

3 优质的缝制品质:

配备面线夹线机构。它可防止起缝时的松线，以及布料反面的鸟巢现象，还消除了面线被污染的情况。通过进一步改进切线机构，使切线后留在布料反面的线残量变短。

Excellent seam quality :

With needle thread gripper, which prevents thread slipping off from the needle hole at the beginning of sewing, and bird-nest problem on the bottom side, and also oil stain problem. For the advanced thread trimming mechanism, the remained thread-end can be shortened.

闭环和开环对比 Comparison of Open & Closed system		
项目 Item	回馈系统 Feedback	对运动偏差即时补偿 Reaction of deviation compensation
开环系统 Open	无 No	无 No
闭环系统 Closed	有 Yes	有 Yes

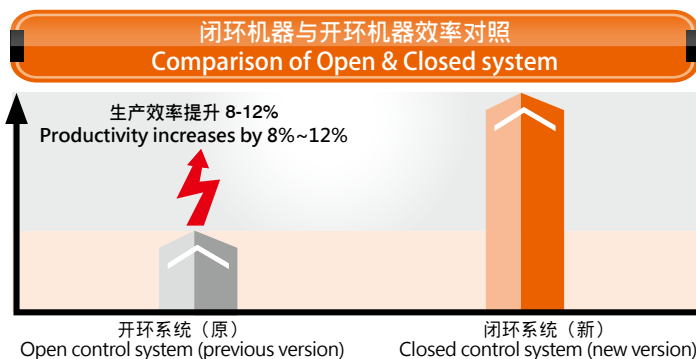

规格

SPECIFICATION

型号 Model	用途 Application	mm ↓	Needle No.	布料厚度 Fabric Weight			mm ↓	S.P.M. (Max)	缝制区域 (X × Ymm) Sewing area (X × Ymm)	按键面板 Key panel	触控面板 Touch panel	
				L	M	H						
LKS-I900D-SS	套结 Bartacking	41.2	DP × 5 #11	[Color bar]			标准 14, 最大 17 (反转抬针时) Standard: 14 Maximum: 17 (moment of reversing and lifting)	0.1~10.0 (0.1 单位)	3300	40 x 30	√	
LKS-I900D-SST					√							
LKS-I900D-HS					√							
LKS-I900D-HST					√							
LKS-I903D-SS	钉扣 Button sewing	41.2	DP × 17 #19	[Color bar]			0.1~10.0 (0.1 单位)	2800	6.8 x 6.8	√		
LKS-I903D-SST						√						

用途 Function	套结 Bartacking	钉扣 Button sewing
送布 Fabric Feeding	间接送布 (步进马达 2 轴驱动方式) Indirect fabric feeding (Driven by 2-axis stepping motor)	
抬压脚方式 Way of presser foot lift	步进马达 Stepping motor	
旋梭 Hook	半旋转标准旋梭或半旋转倍旋梭 Standard hook with semi-rotation or other hook with semi-rotation	
加油方式 Way of adding oil	旋转部: 微量加油 Rotation part: add oil with minimum capacity	
放大缩小功能 Function of Zoom in & Zoom Out	X 方向、Y 方向各自独立缩放 20%~200% (1% 单位) Zoom in and Zoom out 20%~200% independently of X axis and Y axis	
放大缩小方式 Way of Zoom in & Zoom out	线迹长度增减方式 Stitching length adjustment	
标准缝纫图案 Standard Sewing Pattern	100 种图案 100 Patterns	50 种图案 50 Patterns
USB 存储图案数 Max. Number Of Stored Memory Patterns For USB	100 组 100 Combos	
储存容量 Capacity	最大 20000 针 Maximum with 20,000 needles	
马达 Motor	直驱式 AC 伺服马达 550W Direct drive AC Servo Motor 550W	
电源 Power supply	AC 220V ± 10%: 50/60Hz	
额定功率 Power	600W	
重量 Weight	机头 (包括马达): 45 kg, 电子控制箱: 5 kg Machine Head (including motor): 45 kg, Electronic Control Box: 5 kg	

※ 最高缝制速度请根据缝制条件降低速度使用。

※ Max speed varies base on actual sewing condition.

4 Needle 6 Thread Feed-off-the-arm Flatseamer

D007SP - 4 52 - 02 H - T1 - ET / AW1

①机种别 Model

D007SP
S款一般型
General Type

D007SXP
外拨式针距调整型
Stitch-length
Adjustment Type

D007RB
R款一般型
General Type

②针数 Needle Numbers

Needle Numbers

⑤特殊规格 Special Specification

Special Specification

R 弧状车缝
Curved Seaming

H 厚类车缝 (过目、过骨车缝)
Heavy-Weight Material Seaming
(Cross Seaming of Binding / Taping
or Overlock Seam)

AC 布边防卷曲
Anti-Curl Edge

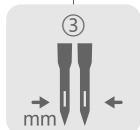

④切刀 Trimmer

01

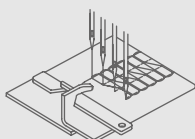

02

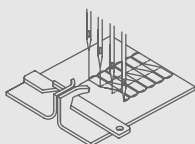

⑦抬压脚规格 Foot Lifter Specification

Foot Lifter Specification

AT 气动式
Pneumatic

ET 电动式
Electric

⑧配件 Device

Device

⑥车缝功能 Seaming Function

Seaming Function

S 裤袜
For Panty Hose

DS 潜水衣
For Diving Suit

T1 织带(女用内衣裤)
For Attaching Woven Tape
(Women's Underwear)

T2 贴条(男用内衣裤)
For Attaching Folded Tape
(Men's Underwear)

4L10 段差型压脚针板组
Step Type Presser Foot and
Needle Plate

4L15

4L20 I 1.0 , 1.5 , 2.0 mm

D007 | Series

四针六线曲臂式并缝机

4 Needle 6 Thread Feed-off-the-arm Flatseamer

D007SP SERIES FEATURES

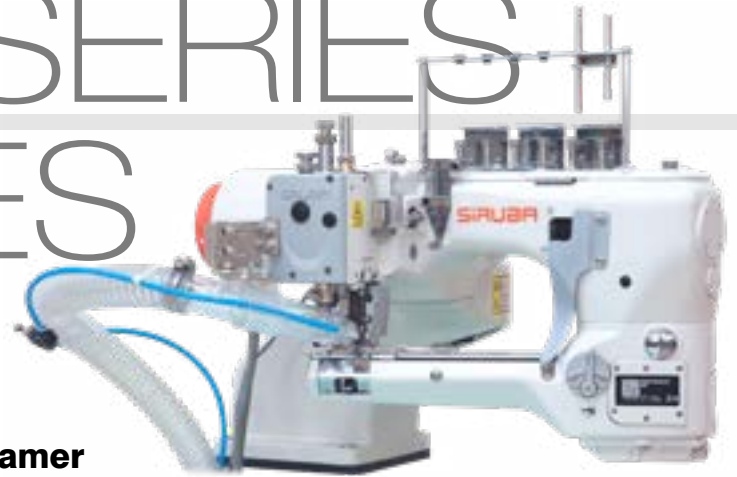

D007SP

四针六线曲臂式并缝机

4 Needle 6 Thread Feed-off-the-arm Flatseamer

D007SP为全新的进阶款，专为贴身衣物与机能型运动衣的叠并缝所设计，提供即强韧又柔和的车缝效果

All new D007SP realizes the strong and delicate sewing quality for intimate fit wear and high-end sportswear's flat-seaming.

特点

FEATURE

线道采用精密陶瓷设计，使过线收线更加顺畅，线迹更均匀稳定，有效提升车缝效果。

The ceramic precision design of the line that makes the winding line is smooth. Stitches are better stable and average, and the sewing effect is effectively improved.



驱动马达与机体结合采一体成形设计，避免组装误差，有效降低车体振动。

The driving motor is combined with the sewing machine to form a single machine. Design to avoid assembly errors and effectively reduce sewing machine vibration.

针座部位改采全包覆一体式设计，防止漏油的可能。

The needle seat is changed to a fully covered and integrated design to prevent the possibility of oil leakage.



D007SXP

四针六线曲臂式并缝机附外拨式针距调整拨杆 4 Needle 6 Thread Feed-off-the-arm Flatseamer Interlock Sewing Machine with Stitch-length Adjustment Lever



特点

FEATURE



延续D007SP的特点，外加外拨式针距调整拨杆设计，可轻易调整各式差动量，满足各种布类所需的车缝品质。

D007SP features with the new design stitch-length adjustment lever for easy adjustment on the differential range, ensuring consistent stitch quality on different types of fabrics.



配件 DEVICE

AW1 外接空压式吸布屑组 *需外接空压机
External compressor type waste suction set
*for compressor compatible

AK 电眼气动切线组
Sensor controlled pneumatic type chain cutter

AW2 吸风马达式吸布屑组
Suction motor type waste suction set

LFA 电动式直向送带装置(搭配T1)
Electric Type Upper Tape Feeding Device (for T1)

AW7 外接空压式吸布屑组 *需外接空压机(搭配AK)
External compressor type waste suction set
*for compressor compatible (for AK)

LF290 抖带轮(搭配LFA)
Untangle Wheel (for LFA)



AW1



AW2



AK



LFA



LF290









规格

SPECIFICATIONS

D007SP - 4 52 - 02 R - T2 - AT/ AK

规格索引, 详细请参考P.174 Specification index, please refer to P.174



- ① 机种别 Model
- ② 针数 Needle Numbers
- ③ 针距 Needle gauge
- ④ 切刀 Trimmer
- ⑤ 特殊规格 Special Specification
- ⑥ 车缝功能 Seaming Function
- ⑦ 抬压脚规格 Foot Lifter Specification
- ⑧ 配件 Device

DS01	 x		 ③					
D007SP/SXP-4 ③-01	4	6	4.8/5.2/6.0	1.6 2.5	1:0.7 1:1.5	8	FL X 118GCS (4 PCS) FLG - 1 (1 PC)	4200
D007SP/SXP-4 ③-02	4	6	4.8/5.2/6.0			6		
D007SP/SXP-4 ③-02R	4	6	4.8/5.2/6.0			6		
D007SP/SXP-4 ③-02H	4	6	5.2/6.0			6		
D007SP/SXP-4 ③-01-S	4	6	5.2/6.0			8		
D007SP/SXP-4 ③-02-S	4	6	5.2/6.0			6		
D007SP/SXP-4 ③-02-T1	4	6	4.8/5.2/6.0			6		
D007SP/SXP-4 ③-01-T2	4	6	5.2/6.0			8		
D007SP/SXP-4 ③-02-T2	4	6	5.2/6.0			6		

Remarks :

FLG - 1 为假针规格, 避免车缝薄软面料的缝份起皱。

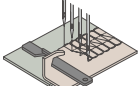
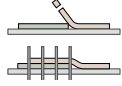
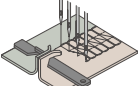
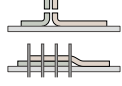
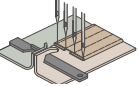
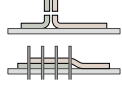
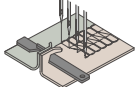
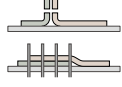
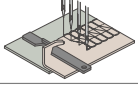
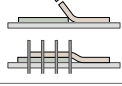
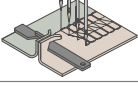
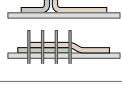
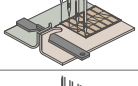
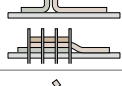
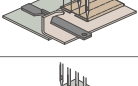
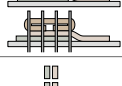
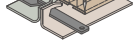
FLG - 1 is a retainer for seaming light / soft materials without seam wrinkling.

Model	Trimming	Cross-section	Fabric Weight		
			Light	Medium	Heavy
D007SP/SXP-4 ③-01					
D007SP/SXP-4 ③-02					
D007SP/SXP-4 ③-02R					
D007SP/SXP-4 ③-02H					
D007SP/SXP-4 ③-01-S					
D007SP/SXP-4 ③-02-S					
D007SP/SXP-4 ③-02-T1					
D007SP/SXP-4 ③-01-T2					
D007SP/SXP-4 ③-02-T2					

D007RB SERIES FEATURES

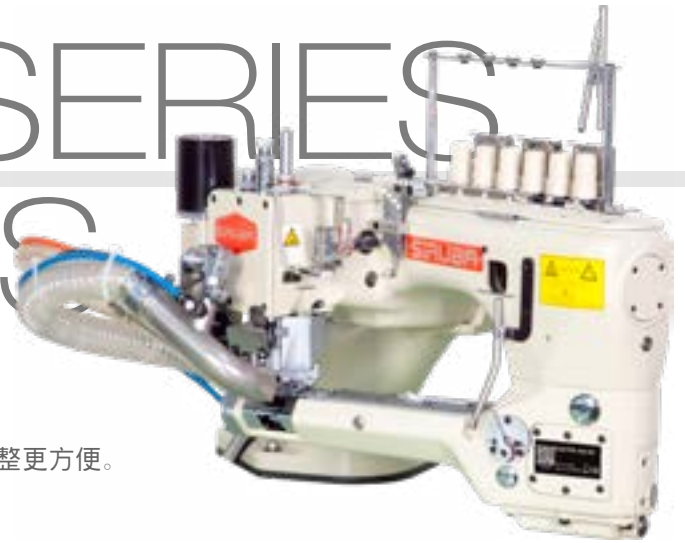

新型后切刀

以电磁阀驱动，横向连杆增加弹簧设计，调整更方便。

New chain cutter

Solenoid type cutter with new design mechanism, which make the connecting rod adjustable easily by the spring.



新型润滑设计

压脚棒封闭机构设计，并有强制供油回油，前盖密封且采用倒回流设计，确保零漏油。

New Lubrication Design

Sealed type presser foot mechanism with active oil supply and return, and the front cover is sealed without opening realize zero oil leakage.



双护针机构

专利双护针设计 (类似三针车的行程)，更稳定控制高速车缝线迹，且较不易断线。

Dual-Needle Guard Mechanism

Patented dual-needle guards (similar to interlock's stroke) make high speed sewing stable and reduce the problem of needle or thread breaking.



高速车缝的稳定度再提升

新型直驱传动设计，主轴结合马达转子，直接传动不需连轴器配合零件精度的提升，高速车缝更稳定。

High Speed Sewing's Stability is Upgraded

New Direct drive design, which the rotor is fixed in the main shaft without connector, is more directly for power delivery. Moreover, spare parts accuracy is upgraded to make a more stable high speed sewing.



全系列并缝上下布边皆可四针包到位

特殊机构设计，适用不同面料，可达到上下布边皆可四针包到位的缝制需求。

Fully Coverstitching For All Lapseamer Series

Unique mechanism design to deal with wide range fabrics fulfills the sewing request for top and bottom plies lapseaming, going fully to both left and right edge of the stitch.



全新专利隐藏式抬压具机构

巧妙将抬压脚电磁铁考量配重藏入机座，节省风力及气动配件；整机轻量化，避震安静，外型简洁；省时省力，提高产能。

Patented Electric Presser Foot Lifter Mechanism

The Solenoid smartly concealed in holding base, saving pneumatic volume and accessories, for less weight, anti-vibration, low noise, well balanced body and tidy looks, resulting in time-saving, labor-saving, and higher productivity.

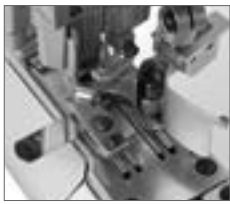

特殊切布刀设计

采用特殊材质，经镜面处理，低磨擦系数，锋利耐用，提高缝制品质。

Special Fabric Trimmer Design

Unique fabric trimmer with special material and mirror finish, resulting in frictionless, sharp & durable trimming to enhance sewing quality.



超细筒机构设计

过针部的悬臂周长仅150mm，小筒型衣物缝制也能得心应手，如童装袖子。

Minimum Cylinder Design

150mm circumference at the needles allows for sewing small tubular work, such as the sleeves seaming of children's wear.



控线更优异

密封式控线钮：防止绕线：提高缝制的顺畅与稳定，过线件全部为陶瓷材质，超耐磨，更滑顺。

Better Threading Control

Sealed thread tension control knob design, preventing from exceptional winding, makes sewing more smooth and stable. Threading parts are all with ceramic material, which is super wear-resistant, super smooth.



送具机构防油

送具机构新增刮油窗设计，下座的防油性能好。

Feed Dog Mechanism Oil Proof

Feed Dog Mechanism is equipped with oil wiper to upgrade sewing bed portion's oil proof level.



标配LED灯，具有5段亮度调节。

Standard equipped LED lights with 5-level brightness adjustment.

配件 DEVICE



AW1 外接空压式吸布屑组

*需外接空压机

External compressor type waste suction set

*for compressor compatible



LFA 电动式直向送带装置(搭配T1)

Electric Type Upper Tape Feeding Device (for T1)



AK9 电眼电动切线组+ 外接空压式吸布屑组

*需外接空压机

Sensor electronic type thread cutter & External compressor type waste suction set

*for compressor compatible



LF290 抖带轮(搭配LFA)

Untangle Wheel (for LFA)



EW2 密封式吸布屑组









*内含吸风马达

The sealed waste suction set

*equipped with suction motor













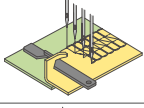
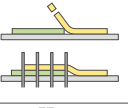

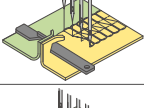
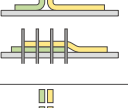

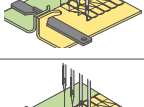
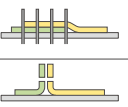
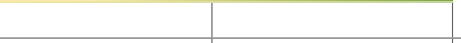
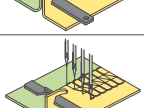
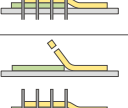

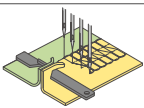
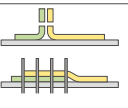

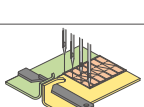
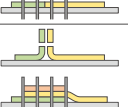
规格/ SPECIFICATION

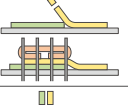
RB01	 x		 + ③	 mm		 mm	 Needle No.	 S.P.M. (Max)	OPTIONAL	
D007RB-4③-01 *	4	6	4.8/ 5.2/ 6.0/ 6.4	1.6	1: 0.7 1: 1.5	8	FL X 118GCS (4 PCS)	4200	AW1/ EW2/ AK9	
D007RB-4③-02 *	4	6	4.8/ 5.2/ 6.0/ 6.4						6	AW1/ EW2/ AK9
D007RB-4③-02R *	4	6	4.8/ 5.2/ 6.0/ 6.4						6	AW1/ EW2/ AK9
D007RB-4③-02H	4	6	5.2/ 6.0						6	AW1/ EW2/ AK9
D007RB-4③-01-S	4	6	5.2/ 6.0						8	AW1/ EW2/ AK9
D007RB-4③-02-S	4	6	5.2/ 6.0						6	AW1/ EW2/ AK9
D007RB-4③-01-DS	4	6	5.2/ 6.0	2.5	8	FLG - 2 (1 PC)	4200	AW1/ EW2/ AK9		
D007RB-4③-02-T1	4	6	4.8/ 5.2/ 6.0					6	AW1/ EW2/ LFA/ AK9	
D007RB-4③-01-T2	4	6	5.2/ 6.0					8	AW1/ EW2/ AK9	
D007RB-4③-02-T2	4	6	5.2/ 6.0					6	AW1/ EW2/ AK9	

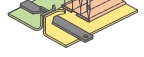
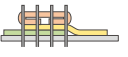
Remarks :

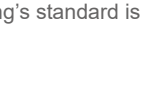
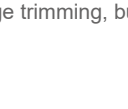
- 标示 * 的型号也供应552机型(5针7线5.2针距)。
- 552机型具特殊针规, 主适用于Spandex面料的缝制, 采购此款机针时请联系SiRUBA代理商以符合原厂规格。
- FLG - 2为假针规格, 避免车缝薄软面料的缝合起皱。

- The model with * mark is available for 552 model (5 needle 7 thread 5.2 needle gauge).
- 552 model with special needle shank spec is mainly designed for Spandex fabrics. While purchasing the needles of 552, please directly contact Siruba to meet original spec.
- FLG - 2 is a retainer for seaming light / soft materials without seam wrinkling.

Model	Trimming	Cross-section	Fabric Weight		
			Light	Medium	Heavy
D007RB-4 ③-01					
D007RB-4 ③-02					
D007RB-4 ③-02R					
D007RB-4 ③-02H					
D007RB-4 ③-01-S					
D007RB-4 ③-02-S					
D007RB-4 ③-01-DS *					
D007RB-4 ③-02-T1					
D007RB-4 ③-01-T2					
D007RB-4 ③-02-T2					

「*」 DS model : 潜水衣规格, 出厂标准为无切布的接并缝(可调整为单切叠并缝)

「*」 DS model : Diving suit sewing's standard is non-edge trimming, butt seam (One side edge trimming lap seam is adjustable.)

LZ SERIES FEATURES



LZ457A

-

143N

-

L

机种别 Model

曲折缝缝纫机
High Speed One Needle Zig-Zag Stitching Machine

表示功能或用途
Function or Purpose

143N 万能车
Universal Sewing

车缝布料
Sewing Material

L 薄布料
Light
M 中厚布料
Medium

LZ1388

-

0

/

L

机种别 Model

曲折缝缝纫机
High Speed One Needle Zig-Zag Stitching Machine

表示功能或用途
Function or Purpose

0	2点人字车缝-最大摆宽5mm Two points zig zag stitching-max width is 5mm
1	2点人字车缝-最大摆宽8mm Two points zig zag stitching-max width is 8mm
3	3点人字车缝-最大摆宽8mm Three points zig zag stitching-max width is 8mm
6	4点人字车缝-最大摆宽8mm Four points zig zag stitching-max width is 8mm
5/140	渔网状3针4点车缝-最大摆宽8mm Fishnet type three stitches four points zig zag stitching-max width is 8mm

车缝布料
Sewing Material

L 薄布料
Light
M 中厚布料
Medium

渔网车 Fishnet Type

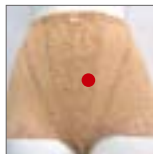

Fishnet

LZ1388-5/140L

渔网状3针4点人字形，适用于束裤、束腹、塑身衣裤、护腰、医疗及运动器材…
Fishnet type three stitches four points zigzag sewing type. Suitable for corsets, fitting clothes, waist protection clothes, medical and fitness equipment, etc.

万用车 Universal Type











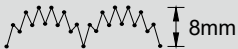
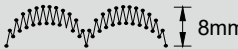

专利万用可换花盘
Patented Universal
Decorative Cam

LZ457A-143N-L

可作装饰缝制，新式流行女用紧身内衣裤及衬衫的缝纫。配合线迹需要备有多种花样凸轮供更换。

Decorative sewing, new type fashion feminine underwear and shirts. Multiple decorative type cam for changing based on needs.

花盘(凸轮)选购表(Optional Cams)

12针迹开式扇形花盘 NP-6358 12-stitch opened scallop cam	24针迹新月扇形花盘 NP-6360 24-stitch crescent scallop cam	24针迹匀称扇形花盘 NP-6464 24-stitch even scallop cam	24针迹匀称扇形花盘 NP-6295 24-stitch even scallop cam
			
4针迹盲缝花盘 NP-6396 Blind stitch cam (4 stitches)	6针迹盲缝花盘 NP-6364 Blind stitch cam (6 stitches)	8针迹盲缝花盘 NP-6480 Blind stitch cam (8 stitches)	12针迹盲缝花盘 NP-6482 Blind stitch cam (12 stitches)
			
普通Z字形花盘 NP-6394 1-step Zig Zag cam	2针3点Z字形花盘 NP-6462 2-step Zig Zag cam	3针4点Z字形花盘 NP-6362 3-step Zig Zag cam	
			

规格/ SPECIFICATION

				用途 Applications	图形 Graph
LZ1388-0	Max 5.0mm (13/64")	2.0mm (13spi)	5000	可做蕾丝花边及肩带缝制等等。 Attaching lace, making shoulder straps etc.	
LZ1388-1	Max 8.0mm (5/16")	1.3mm (20spi)	5000	可做蕾丝镶边及一般人字形的缝纫。 Attaching lace and making general herringbone sewing.	
LZ1388-5/140L	Max 8.0mm	6.5mm	4000	渔网状3针4点人字形。 Fishnet type three stitches four points zigzag sewing type.	
LZ1388-5/140M	Max 8.0mm	6.5mm	4000		
LZ1388-3	Max 8.0mm (5/16")	1.3mm (20spi)	5000	可做紧身衣物或胸衣的松紧带缝制。 Elastic seaming and attaching for corsets or bras.	
LZ1388-6					
LZ457A-143N-L (Universal Type)	Max 8.0mm (5/16")	1.3mm	3400	装饰缝制配合线迹需要而备有多种花样凸轮供更换。 (5.0mm凸轮随车附于配件盒里) Decorative sewing, multiple decorative type cam for changing based on needs. (The 5.0mm cam is attached inside the accessory box with each product.)	
	Max 5.0mm (13/64")	2.0mm			

MDL312 / MDL314



机械式松紧带调节装置

MDL312:送带宽度2" (50mm)

MDL314:送带宽度4" (100mm)

Mechanical metering device for elastic tape

Feeding width: 2"(50mm)

Feeding width: 4"(100mm)

DL3880 SERIES

CHAINSTITCH SEWING MACHINE



DL 388 3 R H - 64 P

机种别
Model

DL 直驱型
Direct drive type

针数
Needle numbers

1	单针 Single Needle
2	双针 Two Needles
3	三针 Three Needles

针向
Needle array

- (双针)横列
(Two Needles)Parallel
- R (双针)纵列
(Two Needles)Tandem
- (三针)斜三针*
(Three Needles)Oblique
- R (三针)三角针*
(Three Needles)Triangular

*注 Remark :

车缝布料
Sewing fabric

- 中厚料
Medium
- H 厚料
Heavy

No.	mm	inch
32	3.2	1/8"
48	4.8	3/16"
64	6.4	1/4"
95	9.5	3/8"

后拖轮
Rear puller

- 无
None
- P 平胶拖轮
Rubber wheel
- G 齿型胶轮
Plastic gear
- I 齿型铁轮
Iron gear
- AP 气动拖轮
Pneumatic Puller

产品特点:

- 一、弯针机构采用的是倾斜弯曲体型的装置，能发挥优越的耐久性。
- 二、加固缝是与平缝机相同都可通过反缝拉杆进行操作，可确实的防止脱线。
- 三、可对缝迹长度进行简单的调节。
- 四、带拖轮装置，拉料更顺畅，缝迹更加平整。



Features

1. The looper mechanism adopts an obliquely curved body type device, which exhibits excellent durability.
2. The bartack function is the same as the lockstitch machine, which can be operated by the reverse stitching lever, which can definitely prevent thread release.
3. The stitch length can be easily adjusted.
4. The puller device makes the cloth feeding smoother and the stitch forms more flat.

规格 SPECIFICATIONS

DL3880	mm	Needle NO.	mm	mm	S.P.M. (Max)	选配 Option	
						后拉轮 Rear Puller	桌板 Table
DL3881	-	TVx7 #14~#21	2	Min: 1.4 mm Max: 4 mm	3500	-P -G -I -AP	DL7000T-T1
DL3882(H)	3.2 / 4.8 / 6.4 / 9.5		4				
DL3882R	-	UY128GAS #14~#20	6	8~10mm	3500	-P -G -I -AP	DL7000T-T1
DL3883(H)	6.4						
DL3883R(H)	6.4						

AA FEATURES



手提式缝袋口机(附加润滑油装置)





手提操作，轻便快捷，每台约 5 公斤。自动切线及压具提升装置，塑胶握把附皮带护盖，可加装挂勾装置，节省人力，机构优良附加润滑油装置，经久耐用。适宜缝合各类纸袋、面粉袋、塑胶编织袋、麻袋及其他袋类的袋口缝合或布头接合染整。



portable bag closer(with lubricating device)

Light weight, easy operation with automatic thread cutter and presser foot lifter. Equipped with lubricating device for oiling and prolonging machine life . For closing all kinds of paper, cotton, PP/PE and gunny bags for packing feeds, seed, fertilizer, flour, chemical powder etc. Also available for closing textile end-join before dyeing.

规格/ SPECIFICATION

A1	 X		 mm	 Needle No.	 S.P.M. (Max)
AA-6	1	1	7.2	D5	1700



MEMO

A series of horizontal dotted lines for writing.

MEMO

A series of horizontal dotted lines for writing.

MEMO

A series of horizontal dotted lines for writing.

MEMO

A series of horizontal dotted lines for writing.

高林股份有限公司

总公司

105 台北市民生东路三段 128 号 11 楼
电话：+886-2-27130232

传真：+886-2-27130318 / +886-2-27130501

台北门市部

台北市士林区社子街 38 号
电话：+886-2-28168808
传真：+886-2-28168806

桃园厂

桃园市桃园区国际路一段 246 号
电话：+886-3-3262128 ~31
传真：+886-3-3262127

宁波高林银箭机电有限公司

浙江省宁波市北仑区龙潭山路 16 号 (邮编：315806)
电话：+86-574-55016666
传真：+86-574-86114666 / 86117799

SiRUBA 越南子公司

Lô số 3, Khu biệt thự Hoa Phượng, xã An Khánh,
huyện Hoài Đức, Hà Nội
电话：+84-024-73079888

SiRUBA 越南胡志明市办事处

559-561 Hoàng Văn Thụ, Phường 4, Quận Tân Bình,
Thành Phố Hồ Chí Minh
电话：+84-028-39480088

KAULIN MFG. CO., LTD.

HEAD OFFICE

11F., No.128, Sec. 3, Minsheng E. Rd., Songshan
District, Taipei City, Taiwan.
TEL : +886-2-27130232
FAX : +886-2-27130318 / +886-2-27130501

RETAIL DEPT.

No.38, Shezi St., Shilin Dist., Taipei City 111, Taiwan.
TEL : +886-2-28168808
FAX : +886-2-28168806

TAOYUAN FACTORY

No.246, Sec. 1, Guoji Rd., Taoyuan Dist., Taoyuan
City, Taiwan.
TEL : +886-3-3262128 ~31
FAX : +886-3-3262127

KAULIN M.&E. INDUSTRIAL CO.,LTD.

No. 16 Long Tan Shan Road Bei Lun District, Ningbo
City Zhejiang Province China.
TEL : +86-574-55016666
FAX : +86-574-86114666 / 86117799

SiRUBA MACHINERY VIETNAM CO., LTD.

Lot 3, Hoa Phuong Villa Area, An Khanh Commune,
Hoai Duc District, Hanoi
TEL : +84-024-73079888

SiRUBA Machinery Vietnam CO., (HCMC Branch)

559-561 Hoang Van Thu, Ward 4, Tan Binh District,
Ho Chi Minh City
TEL : +84-028-39480088



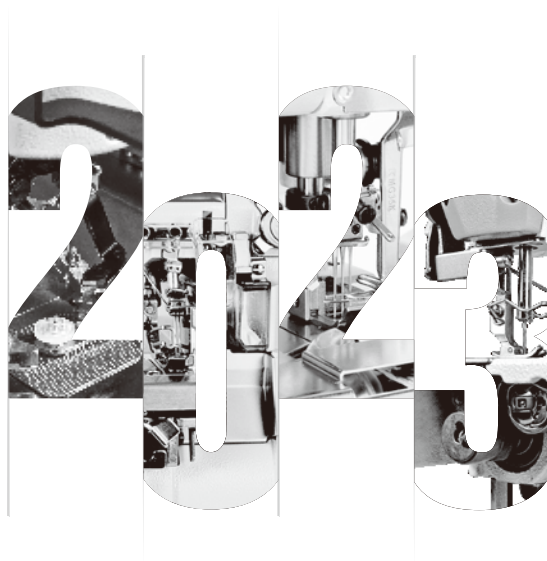

 高林股份有限公司
KAULIN MFG. CO., LTD.



ISO 9001:2000
ISO 14001:2004

由於對產品的改良及更新，本產品型錄中之產品規格及外觀的修改恕不事先通知
The specification and/or appearances of the equipment described in this catalogue are
subject to change without previous notice because of modification.

C.S2023-01C SEP 2023

